

A SERIES OF ION ACCELERATORS FOR INDUSTRY

BN Sukhina, NI Alinovsky, IL Chertok, SN Chumakov, NS Dikansky, AD Goncharov
Budker Institute of Nuclear Physics, 630090, Novosibirsk, Russia

Ion accelerators intended for application to electronics industry, surface modification and other technologies are described. A series of the accelerators are characterized by horizontal ion beam position. The energy ranges from 20 KeV to 1.5 MeV. In the frame of this project, the ION-300, ION-1500 installations were designed, built and successfully tested. The main rectifier and high voltage terminals of the accelerators have the power supply of the increased frequency. The high voltage terminals are supplied with a power up to 2.2 KW using special small-size resonant transformers. The accelerators are provided with ion beam separation on full energy, oil-free vacuum, high voltage isolation (SF_6), and an intellectual automatic control system with the IBM PC host computer. A special set of technical, hardware and software decisions allows us to meet the reliability requirements.

I. THE ION ACCELERATOR ION-1500 FOR INDUSTRY

Table 1. THE MAIN PARAMETERS.

Energy range , KeV	500-1500
Energy instability,	0.001
Ripple of accelerating voltage,	0,0005
Total ion current , mA	1.5
Output beam diameter , mm	10
Separating-magnet radius , mm	1300
Induction in sep.-magnet, Tl	1.0
Range of the masses , A.M.U.	1-80
Gas pressure, MPa	0.6
Dimensions L * B * H, m	5.5 * 3. * 1.7

A. THE DESIGN.

A general view of the installation is shown on Fig.1

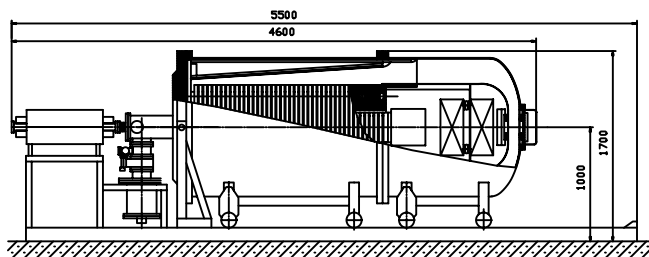

Figure. 1. The ION-1500 Schematic layout

The main units of the accelerator are: the main high voltage rectifier; the acceleration tube and the ion channel; the ion source located under the potential of the main rectifier; the high voltage terminal with a transformer for power transmission; a separating magnet with the power supply system; an oil free pumping system; a power supply system and a computer control system. The high voltage units of the accelerator are located in volume filled

with gas SF_6 under a pressure to 0.6 MPa. The horizontal position of the accelerating tube gives some advantages to provide high operational characteristics of the accelerator.

B. THE MAIN HIGH VOLTAGE RECTIFIER

uses a single-phase cascade multiplier with an inductive connection, which has high loading ability / to 25 mA / and a small factor of ripple. The rectifier is supplied from a controlling machine-generator at a frequency of 1 KHz. The use of the increased frequency allows us to decrease the weight of the rectifier and simplifies its design. The design of the horizontally located rectifier comprises consecutive connections of the identical sections in the form of disks, 40mm thick. Each section contains the secondary winding of the transformer, ballast and measuring resistors. The primary winding of the transformer is included in a resonant circuit, which is common for all the sections and separated from the sections by a gas insulating gap with a variable step to optimization the inductive connection. The rectifier voltage has the linear characteristics of numbers of sections. A high loading ability corresponds to large reserved energy in the condensers; therefore, its fast switching-off is provided in the case of breakdowns.

C. THE ACCELERATION TUBE

is installed horizontally on the axis of the secondary windings of the main rectifier. The section of the tube is made of ceramic and metal chevron-shaped rings. The ION-300 acceleration tube consists of one section, the ION-1500 acceleration tube consists of 5 sections of this type. The constant magnets are installed between the sections for reducing of the full energy of the secondary electrons, thus decreasing the radiation background. The tube doesn't contain organic materials. As a result, its the electrical strength and life time are substantially increased. For proportional distribution of high potential along the acceleration tube, a high voltage divider is used.

D. THE ION CHANNEL

is equipped with the devices for measuring of the beam parameters, such as, the magnetic-modulation meters of average beam current, a sliding meter of full beam current (the Faraday's cap), a beam profile monitor.

E. THE RF TYPE ION SOURCE

has the following parameters:

Energy of ions, KeV	10
Ion current, mA	1.5
Power consumption, W	300
Gas flow, cm ³ /h	15
RF frequency, MHz	50

The quartz tube of the RF ion source has a silicon rubber sealing. The RF circuit is placed perpendicular to the axis of the quartz tube. A ferromagnetic extractor with two ceramic ring magnets has a constant magnetic field parallel to the direction of ion extraction. The generator, pyzoelectrical valve for gas supply consumption and a cylinder with a working gas are under the potential of a high voltage emitter and are isolated from the accelerating potential of the source by the ceramic tube. The source performance was tested for the following gases: H_2 , He , N_2 , O_2 , CO_2 , Ar , BF_3 , and SF_6 . The time up to failures, when working with oxygen, was more than 300 hours.

F. THE HIGH VOLTAGE TERMINAL

serves for ion source power supply. The electrical power (to 0.3 KW) for power supply of the terminal at a frequency of 20 KHz is transmitted by a resonant transformer of the armoured type, the primary and secondary circuits of which are inductively coupled and divided by a high voltage insulating gap. The high voltage gap is 105 mm, and the ferrite core-cups are 210 mm in diameter. The secondary coil of the transformer doesn't need the forced cooling, because it is placed in the insulation gas (SF_6). The terminal structure consists of a set of controlled functional modules [1], connected with the computer by a duplex fiber optic communication line. The feature of these modules is the use of the increased power supply frequency in combination with the magnetic nonlinear regulating elements: magnetic amplifiers characterized by high efficiency, high specific power, ability of limiting the current of a short circuit. A set of the unified supply units is suitable for the supply of the RF ion source, duoplasmatron, or other similar devices.

G. THE MAGNET-SEPARATOR

of the dipole type (with the magnetic field recession parameter $n=0$) is used to separate the ion beam accelerated to a full energy. The magnet-separator consuming the constant current from a controlled machine generator working at a frequency of 1 KHz and a 8 KW power with subsequent transformation into constant current.

H. THE OIL-FREE PUMPING SYSTEM

consists of turbo-molecular pumps. The working vacuum is about $1 \cdot 10^{-4}$ Pa inside the acceleration tube.

I. THE COMPUTER CONTROL SYSTEM

provides: the direct control of the accelerator parameters, the control of the ion source parameters, the measurement of the ion beam parameters, the emergency switching-off at overloading or high voltage breakdown. The control system consists of the central computer IBM PC / AT, a set of the functional modules in the CAMAC standards, and a series of special electronic units. The high voltage terminal is controlled via a duplex optic-fiber line by a pulse width-modulated signal. The of continuous ion currents to and after magnet-separator are measured by magnet-modulation meters of average current. The ion beam profile is measured with the help of a relocating gauge (thin wire). It is possible to measure the ion mass spectrum at the magnet-separator output and to display the data. The fast switch-off of

the main high voltage rectifier is made by thyristors switch for time which is substantially less than the the period of the feeding network in order to prevent from the irreversible processes in its elements. The ions C^+ , B^+ , and N^+ with an energy up to 1200 KeV and full ion current up to 1.5 mA are obtained. The acquired experience and the successful testing of the accelerator ION-1500 allow us to develop the "ION" type accelerators.

II. THE ACCELERATOR ION-300 FOR INDUSTRY

Table 3. THE MAIN PARAMETERS

Energy range, KeV	100-300
Maximum full current ,mA	5
Separating magnet radius, mm	600
Range of the masses, A.M.U	1-80
Maximum gas pressure, MPa	0,07
Dimensions LxBxH, m	$3.1 \cdot 1.5 \cdot 2.0$

A. THE DESIGN.

A general view of accelerator ION-300 is shown in Fig.2

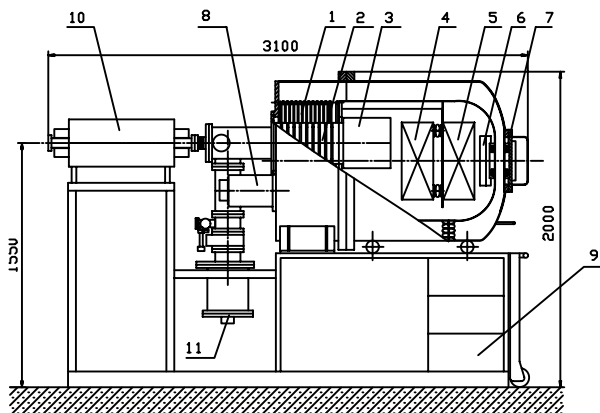

Figure. 2. The ION-300 schematic layout

1-the main high voltage rectifier; 2-the acceleration tube; 3-the ion source; 4,5-the high voltage terminal; 6,7-the power transmission transformer; 8-the transformers; 9-the 3-phase powerful generator; 10-the magnet-separator; 11-the oil-free pumping system.

B. THE MAIN HIGH VOLTAGE RECTIFIER

used in the accelerator ION-300 works at a frequency of 20 KHz. The rectifier represents a capacitive voltage multiplier with a sequential feeding of the cascades. The feeding is made from a 3-phase powerful electronic generator. The frequency of voltage pulsation at the rectifier output is 120 KHz. This allowed us to considerably decrease the energy accumulated in the condensers of the rectifier column and to reduce the degree degradation of the insulators and metal electrodes of the tube, which is depends on the discharge energy in the case of breakdown.

C. THE ION SOURCE

of the RF type and its unified two crate power supply system, which contains two network stabilizers, two control stations, and a set of the current and voltage sources are located in a high

voltage terminal under the potential of the main rectifier. The terminal electrical power supply is made irrespective of the main rectifier at 20 KHz via a resonant transformer, whose primary and secondary coils are divided by a high voltage gas insulating gap. With a 60 mm gap between the coils, such transformers can transmit the electrical power to 2.2 KW at a efficiency about 0,9.

D. THE DISTRIBUTED COMPUTER CONTROL SYSTEM

is specially designed for applying to electro-physical installations with subsystems, located under high potentials and working under the conditions of powerful electrical interference and breakdowns. The distributed control system [1] consists of the central computer IBM PC XT / AT and three through six intelligent multifunctional control stations. Each local station controls directly one of the subsystems of the installation according to its functional purpose and design under high potential as well. All the stations are connected with the central computer by the duplex optic-fiber link. The program in the central computer consists of several subprograms working independently in the regimes of time division. The central processor-manager operates with peripheral processes, each of them controls one of physical subsystems of the installation. The peripheral processor one-paid module has a complete set of functional input/output devices to realize the control algorithms and stabilize the analog parameters, such as the accelerator energy, ion source current, magnet-separator current, etc. The control station is designed to withstand a powerful pulse interference. The processor-module has an automatic restart in the accidental situation [1].

III. REFERENCES

[1] SN Chumakov, AD Goncharov, AN Malygin, VP Ostanin, BN Sukhina, VS Tupikov, "Advances in power supply and control system for electrostatic accelerators", The 1995 Particle Accelerator Conference.