

INTERNATIONAL ATOMIC ENERGY AGENCY
TECHNICAL COMMITTEE MEETING

**"INNOVATIVE APPROACHES
TO
FUSION ENERGY"**

Jointly Organized by the International Atomic Energy Agency
and Lawrence Livermore National Laboratory

Pleasanton, California, USA
October 20-23, 1997

CONF-971079

**INTERNATIONAL ATOMIC ENERGY AGENCY
TECHNICAL COMMITTEE MEETING**

***“INNOVATIVE APPROACHES
TO FUSION ENERGY”***

**Jointly Organized by the International Atomic Energy
Agency and Lawrence Livermore National Laboratory**

***Pleasanton, California, USA
October 20-23, 1997***

References

1. H.Momota, A. Ishida, Y.Kohzaki, G.H.Miley, S.Ohi, M.Ohnishi, K.Sato, L.C. Steinhauer, Y.Tomita, and M.Tuszewski; "Conceptual Design of the D-3He Reactor ARTEMIS," *Fusion Technology* 21 (1992) 2307
2. A.L.Hoffman and J.T.Slough;"Field-Reversed Configuration Lifetime Scaling Based on Measurements from the Large s Experiment," *Nuclear Fusion* 33 (1993) 27
3. S.P.Auerbach and W.C.Condit; "Classical Diffusion in a Field-Reversed Mirror," *Nuclear Fusion* 21 (1981) 927
4. M.H.Hsiao and G.H.Miley;"Particle-Confinement Criteria for Axisymmetric Field-Reversed Magnetic Configuration," *Nuclear Fusion* 24 (1984) 1029
5. Y.Tomita and H.Momota; "Steady Equilibrium of a Cylindrically Symmetric Plasma Sustained by Fueling," *J. Plasma and Fusion Research* 69 (1993) 801

CONF-971079

**INTERNATIONAL ATOMIC ENERGY AGENCY
TECHNICAL COMMITTEE MEETING**

***“INNOVATIVE APPROACHES
TO FUSION ENERGY”***

**Jointly Organized by the International Atomic Energy
Agency and Lawrence Livermore National Laboratory**

***Pleasanton, California, USA
October 20-23, 1997***

The Purpose of this Meeting is to provide a forum for discussion of approaches to fusion other than conventional tokamaks and stellarators, such as

- quasi-steady-state systems (mirrors, RFP's, spheromaks, FRC's, spherical tori,...)
- short-pulsed systems (liners, Z-pinch variants, plasma foci, novel ICF, ...);
- fusion technology innovations

The Programme Committee:

L.J. Perkins, Livermore, USA (Co-Chair)
D.D. Ryutov, Livermore, USA (Co-Chair)
R. Blanken, US DoE, Washington DC, USA
T.J. Dolan, IAEA, Vienna, Austria
J. Herrera (Mexico City, Mexico)
P. Kaw (Bhat, Gandhinagar, India)
G. Kessler (Karlsruhe, Germany)
V. Koidan (Novosibirsk, Russia)
H. Momota (Nagoya, Japan)
L.-J. Qiu (Hefei, China)

Local Organization:

Gloria Davalos
Wanda Robinson

Programme

Sunday, October 19

16.00-19.00 Registration - First Floor, Livermore Rooms

18.00-20.00 Reception (no-host bar) - First Floor, Livermore Rooms

Monday, October 20

7.30-8.30 Registration - Second Floor Foyer (by Dublin Room)

8.30-10.15 Opening Session. Chairman: K. Thomassen (Livermore, USA) - Second Floor, Dublin/Pleasanton Rooms

8.30-8.45	T. Dolan (IAEA)	Opening Remarks
8.45-9.30	R. Schock (Livermore, USA)	Energy, Global Sustainability, and National Security (Invited Talk)
9.30-10.15	R. Goldston (Princeton, USA)	Implications of Recent Tokamak Research for Other Approaches to Toroidal Confinement (Invited Talk)

10.15-10.50 Coffee Break

10.50-12.30 High-Beta Pulsed. Chairman: L. Qiu (Hefei, China) - Second Floor, Dublin/Pleasanton Rooms

10.50-11.15	V. Mokhov (Arzamas, Russia)	Studying the Feasibility of Thermonuclear Magnetized Plasma Generation in Magnetic Implosion System Mago
11.15-11.40	K. Schoenberg (Los Alamos, USA)	Affordable Development of Fusion Using Magnetized Target Fusion
11.40-12.05	V. Koidan (Novosibirsk, Russia)	Fast Heating of a Dense Plasma and Prospects of $\beta \geq 1$ Experiments at the GOL-3-II Facility
12.05-12.30	F. Thio (Auckland, N. Zealand)	An Embodiment of the Magnetized Target Fusion Concept in a Spherical Geometry with Stand-Off Drivers

12.30-14.00 Lunch

14.00-15.35 Technology 1. Chairman: M. Fujiwara (Nagoya, Japan) - Second Floor, Dublin/Pleasanton Rooms

14.00-14.45	G. Kessler (Karlsruhe, Germany)	The Future of Fission Reactors (Invited Talk)
14.45-15.10	L. Qiu (Hefei, China)	Fusion-Fission Hybrid Reactor Research Program in China
15.10-15.35	M. Ishikawa (Kyoto, Japan)	Numerical Study of Direct Energy Converters for a Deuterium-Helium FRC Fusion Reactor

15.35-16.00 Coffee break

16.00-19.00 Poster Session 1. Pulsed Fusion Systems, ICF, Technology - Second Floor, Concord Room

Tuesday, October 21

8.30-10.30 FRC's and D-³He. Chairman: G. Miley (Urbana, USA) - First Floor, Amador Rooms

- | | | |
|-------------|----------------------------------|---|
| 8.30-9.15 | H. Momota (Nagoya, Japan) | Attractive Characteristics and Issues for Developing Deuterium and Helium 3 Fusion Reactor on the Base of a Field-Reversed Configuration (Invited Talk) |
| 9.15-9.40 | A. Hoffman (Seattle, USA) | Flux Build-Up in FRCs Using Rotating Magnetic Fields |
| 9.40-10.05 | S. Goto (Osaka, Japan) | Experimental Study on Translation and Confinement-Related Phenomena of an FRC Plasma |
| 10.05-10.30 | R. Kurtmullaev (Troitsk, Russia) | Self-Organized Compact Torus as Approach to Low-Scale Fusion System with One-Step Shock Ignition |

10.30-10.50 Coffee Break.

10.50-12.30 Technology 2. Chairman: G. Kessler (Karlsruhe, Germany) - First Floor, Amador Rooms

- | | | |
|-------------|-------------------------------------|---|
| 10.50-11.15 | E. Kruglyakov (Novosibirsk, Russia) | Axisymmetrical Gas Dynamic Trap as a High Power 14 MeV Neutron Source. Modern Version |
| 11.15-11.40 | R. Wooley (Princeton, USA) | Synergistic Use of Liquid Lithium as Self-Protecting First Wall, Tritium Breeder, and LMMHD Electric Power Producer |
| 11.40-12.05 | V. Karas' (Kharkiv, The Ukraine) | Linear Induction Accelerator for Charge-Neutralized Ion Beams in Inertial Confinement Fusion |
| 12.05-12.30 | V. Chernyshev (Arzamas, Russia) | High-Power Explosive Magnetic Energy Sources for Thermonuclear Applications |

12.30-14.00 Lunch

14.00-15.35 Dipoles and Electrostatic. Co-Chairmen: M. Porkolab, J. Kesner (Cambridge, USA) - First Floor, Amador Rooms

- | | | |
|-------------|---------------------------------|---|
| 14.00-14.25 | M. Mauel (New York, USA) | The Dipole Plasma Confinement Concept |
| 14.25-14.50 | J. Dawson (Los Angeles, USA) | The Magnetic Dipole as Attractive Fusion Reactor |
| 14.50-15.15 | V. Pistunovich (Moscow, Russia) | Galateya Traps as Alternative Basis for Fusion Reactors |
| 15.15-15.40 | R. Nebel (Los Alamos, USA) | The Los Alamos Intense Neutron Source and the Penning Fusion Experiment |

15.40-16.00 Coffee Break

16.00-18.30 Special Discussion Session: Potential Impact of Technology Advances on Alternative Reactor Concepts. Chairman: J. Dawson (Los Angeles, USA) - First Floor, Amador Rooms
Panelists (in an alphabetic order)*: V. Chernyshev (Arzamas, Russia), S. Cohen (Princeton, USA), A. Friedman (Livermore, USA), H. G. Logan (Livermore, USA), H. Momota (Nagoya, Japan), S. Nakai (Osaka, Japan)

* Not all confirmations received

Some issues for discussion:

- What fusion-related technology advances can one expect in the next 20 years?
- What technological issues should be resolved to make your concept of the fusion reactor workable?
- What impact would have the following technology advances on your system: High-efficiency direct energy converters; New remote maintenance capabilities (e.g., a frequent replacement of the reactor core); Small-bore very high field coils; Possibility of increasing average heat load on the wall; Neutronically thick liquid walls; High-precision NBI's with a capability of pre-programmed time-variation of the energy; New laser drivers?
- What are your expectations for other major breakthroughs in fusion-related technologies?
- In what areas of technology development could/should the fusion community take the lead?

19.30-21.30 Conference Banquet (No-host bar from 18.30) - Second Floor, Dublin/Pleasanton Rooms

Wednesday, October 22

8.30-10.30 Spherical Tori and Spheromaks. Chairman: R. Blanken (Washington DC, USA) - Second Floor, Dublin/Pleasanton Rooms

8.30-9.15	T. Todd (Culham, United Kingdom)	The Spherical Tokamak Route to Fusion Power Applications (Invited Talk)
9.15-9.40	M. Peng (Princeton, USA)	Scientific Innovations of Interest to NSTX Research
9.40-10.05	B. Hooper (Livermore, USA)	Addressing Spheromak Physics in the Sustained Spheromak Physics Experiment, SSPX
10.05-10.30	M. Yamada (Princeton, USA)	MRX-CT Experiment, Study of Compact Toroids Formed by Induction and Merging

10.30-10.50 Coffee Break

10.50-13.00 Poster Session 2: Closed and Open Field Line Configurations - Second Floor, Concord Room

13.00-14.00 Lunch

14.00-15.35 RFPs and Stellarators. Chairman: H. Momota (Nagoya, Japan) - Second Floor, Dublin/Pleasanton Rooms

14.00-14.45	S. Prager (Madison, USA)	The Reversed Field Pinch: Advances and Prospects (Invited Talk)
14.45-15.10	K. Hayase (Tsukuba, Japan)	Divertor RFP Plasma and Some Considerations at Ignited Plasma Conditions
15.10-15.35	P. Moroz (Madison, USA)	Two Novel Compact Toroidal Concepts with Stellarator Features

15.35-16.00 Coffee Break

16.00-18.30 Special Discussion Session "International Collaboration in Alternative Concepts". Chairman: T. Dolan (IAEA) - Second Floor, Dublin/Pleasanton Rooms. Panelists (in an alphabetic order): R. Goldston (Princeton, USA), G. Kessler (Karlsruhe, Germany), E. Kruglyakov (Novosibirsk, Russia), I. Lindemuth (Los Alamos, USA), H. Momota (Nagoya, Japan), L. Qiu (Hefei, China).

Some issues for discussion:

- Coordination of research;
- Sharing equipment;
- Exchanging experimental teams for specialized measurements;
- National and international "user facilities";
- Ways of raising the status of alternative research within the national programs;
- Optimum selection procedures for identifying the most promising concepts;
- Possible role of the IAEA and the ITER process;
- Possible contribution of developing countries;
- Similarities and differences with other international projects.

19.00-21.00 A Satellite Meeting Organized by I. Lindemuth (Los Alamos, USA): "Magnetized Target Fusion"

Thursday, October 23

8.30-10.30 Inertial Confinement Fusion. Chairman: E. Panarella (Hull, Canada) - Second Floor,
Dublin/Pleasanton Rooms

- | | | |
|-------------|------------------------------|---|
| 8.30-9.15 | S. Nakai (Osaka, Japan) | Prospects of Inertial Fusion Energy - Technical and Economical Feasibilities (Invited Talk) |
| 9.15-9.40 | M. Tabak (Livermore, USA) | Ignition and High Gain with Ultra-Powerful Lasers |
| 9.40-10.05 | R. Bangerter (Berkeley, USA) | Innovative Approaches to Heavy Ion Inertial Fusion - Revolution or Evolution? |
| 10.05-10.30 | A. Friedman (Livermore, USA) | Beam Dynamics for HIF |

10.30-10.50 Coffee Break

10.50-12.30 Mirrors. Chairman: V. Koidan (Novosibirsk, Russia) - Second Floor,
Dublin/Pleasanton Rooms

- | | | |
|-------------|---------------------------------|--|
| 10.50-11.15 | K. Yatsu (Tsukuba, Japan) | Plasma Confinement in Gamma 10 and Tandem Mirror Reactor |
| 11.15-11.40 | A. Ivanov (Novosibirsk, Russia) | Experimental Studies of Plasma Confinement and Heating in Gas-Dynamic Trap |
| 11.40-12.05 | R. Post (Livermore, USA) | Open-Ended Systems: Some Possible New Directions |
| 12.05-12.30 | T. Tamano (Tsukuba, Japan) | D-He ³ Tandem Mirror Approach |

13.00-14.00 Lunch

14.00-15.35 Z-pinchs and Plasma Foci. Chairman: V. Mokhov (Arzamas, Russia) - Second Floor,
Dublin/Pleasanton Rooms

- | | | |
|-------------|------------------------------|--|
| 14.00-14.45 | V. Smirnov (Troitsk, Russia) | Development of Double Liner Scheme - Dynamic Hohlraum for Pellet Ignition (Invited Talk) |
| 14.45-15.10 | M. Sadowski (Swierk, Poland) | Unsolved Problems and Future Prospects of Plasma-Focus Research |
| 15.10-15.35 | H. Soliman (Cairo, Egypt) | Dense Plasma Focus Dynamics |

15.40-16.00 Coffee Break

16.00-17.00 Summary Session. L.J. Perkins, D. Ryutov (Livermore, USA) - Second Floor,
Dublin/Pleasanton Rooms

Poster session 1: Pulsed Fusion Systems, ICF, Technology (Monday, October 20, 16.00-19.00) - Second Floor, Concord Room

1. J. Barnard (Livermore, USA) Induction Accelerators for Heavy Ion Fusion: Architectures and Options
2. Z. Henis (Yavne, Israel) Measurements of Axial magnetic Fields Produced by the Interaction of Circularly Polarized Laser Light with Plasma in a Miniature Magnetic Bottle
3. R. Kaita (Princeton, USA) Development of Plasma Heating and Diagnostic Techniques on CDX-U for the Spherical Torus
4. V. Koidan (Novosibirsk, Russia) Concept of a Pulsed Multi-Mirror Reactor
5. A. Kukushkin (Moscow, Russia) Self-Formation and Self-Compression of a Heterogeneous Spheromak-Like Magnetic Configuration in Short-Pulse Discharges and Proof of Concept Experiments on the Magnetic Implosion and Compression of a Heterogeneous Compact toroid
6. I. Lindemuth (Los Alamos, USA) US/Russian Collaboration: Progress in Magnetized target Fusion
7. C. Marshall (Livermore, USA) Diode-Pumped Solid-State Laser-Driven Inertial Fusion Energy
8. T. Miyamoto (Tokyo, Japan) Fusion Approach Based on Sheet Z-Pinches
9. R. Moir (Livermore, USA) Ultra-High Wall Load Fusion Concepts with Liquid Walls
10. E. Panarella (Hull, Canada) A Review of Spherical Pinch Research
11. P. Parks (San Diego, USA) Magneto Inertial Confinement: A High-Gain Approach to Pulsed Power Fusion
12. J. Perkins (Livermore, USA) Coulomb Barrier Reduction Methods for Fusion
13. M. Schaffer (San Diego, USA) Slow Liner Fusion
14. R. Siemon (Los Alamos, USA) Magnetized Target Fusion: Principles and Status
15. P. Sheehy (Los Alamos, USA) Computational Modeling of Joint US-Russian Experiments Relevant to Compression/Magnetized Target Fusion
16. V. Yakubov (Arzamas, Russia) On Possibility of Low-Dense Magnetized D-T Plasma Ignition Threshold Achievement in MAGO System
17. Y. Yasaka (Kyoto, Japan) Basic Experiment on a Traveling Wave Direct Energy Converter for D^3He Fusion Reactor
18. V. Zoita (Bucharest, Romania) Dense Pinch-Driven Fusion-Fission Hybrid Reactor

Poster session 2: Closed and Open Field Line Configurations (Wednesday, October 22, 10.50-13.00) - Second Floor, Concord Room

1. M. Brown (Swarthmore, USA) Spheromak Formation, Equilibrium and Merging Experiments on SSX
2. S. Cohen (Princeton, USA) Elimination of Plasma-Material Interaction Problem in an Advanced Fuel Magnetic Fusion Reactor
3. G. Dimov (Novosibirsk, Russia) Tandem Mirror Fusion Reactor Concept. The Key Problems
4. A. Frank (Moscow, Russia) Galathea-Belt Plasma Configurations - Main principles and First Experimental Results
5. A. Ivanov (Novosibirsk, Russia) Fusion Reactor Concept on the Basis of Gas Dynamic Trap
6. T.R. Jarboe (Seattle, USA) Steady-State Inductive Helicity Injection for Flux Conserving Spheromaks
7. H. Ji (Princeton, USA) Physics Issues and Engineering Design of MRX-CT
8. V. Khvesyuk (Moscow, Russia) Alfvén Instabilities in FRC
9. V. Khvesyuk (Moscow, Russia) Analysis of D^3He - 6Li Fuel Cycle
10. G. Miley (Urbana, USA) IEC Concept for Fusion Applications
11. S. Okada (S. Okada, Japan) Heating of FRC by a Magnetic Pulse and a Proposal for Axial Magnetic Compression
12. V. Pistunovich (Moscow, Russia) Mixina Concept for the Experimental Galathea Reactor
13. M. Schaffer (San Diego, USA) Helical-D Pinch
14. S. Shiina (Tokyo, Japan) Resistive Kink-Mode-Stable, Higher Beta Reversed Field Pinch Configuration with RF Current Drive
15. L. Steinhauer (Seattle, USA) High-Beta Relaxed Plasmas for Fusion Applications
16. Y. Tomita (Nagoya, Japan) Collisionless Pitch Angle Scattering and Related Loss Process of Plasma Particles in a Field Reversed Configuration

The time allotted for an invited talk is 35 minutes, plus 10 minutes for discussion; the time allotted for a contributed talk is 20 minutes, plus 5 minutes for discussion

Presenters of the poster papers are encouraged to display their material before the beginning of the morning session and keep it displayed for the entire day. Please don't forget to remove your poster in the evening.

Please contact the Registration Desk as early as possible if you have any special requests with regard to the audio-visual equipment.

OPENING SESSION

Energy, Global Sustainability, and National Security in the 21st Century

R. N. Schock

**Lawrence Livermore National Laboratory
Livermore, California**

The world is in the midst of unprecedented changes that are altering the way we view stability and security, and energy is *the* key to whether these changes improve the human condition in the 21st century, or make it worse. If sustainability is to be achieved, the global population must be stabilized, and the environment must be protected. Population is most likely to be stabilized through increases in standards of living, which requires ample supplies of the basic elements, food, water, materials, and energy. Of these, energy is the only one that is both necessary and sufficient. At present, Organization for Economic Cooperation and Development (OECD) countries use three-fourths of the world's annual energy consumption, yet have only 20% of the population. The rest of the world is increasing its energy consumption at three to four times the rate of OECD countries. China is now the second highest energy-consuming country in the world, after the United States, and Asia is about to overtake North America as the region where most energy is used. With current sources and emerging technologies, the world will certainly require a substantial mix of all of the energy forms we now utilize. Yet energy production and use are responsible for much of the atmospheric and ocean air pollution. Without sustainability, the world faces catastrophes such as famine, disease, war, and mass migration, which are threats to everyone's security. Technology has provided and will continue to provide the key to converting energy into useful work and to impacting sustainable development.

There are energy technologies that promise to meet this challenge, if they are developed soon enough. Fuel cells are likely to increase the efficiency of energy conversion in both stationary devices and vehicles by factors of 2 or more. In the next 20 years we will probably see substantial numbers of high-performance hybrid-electric automobiles that attain 35 km/l fuel economy and carry five passengers with a 480-km range. We need only look back to see that the real prices of raw materials have steadily fallen throughout this century, almost without exception, because technology has extended the resources. On the issue of the environment, technology has steadily improved it in most of the world, particularly in the developed world. We have good reason to believe that, using current and emerging technologies, we can economically use advanced energy technologies to avoid 25–50% of the carbon dioxide that otherwise would enter the atmosphere and to stabilize the CO₂ levels in the

atmosphere without significant economic impact, if we begin now. Similarly, we can avoid much of the urban air pollution that now results in substantial health-related costs. The development of economically viable fusion energy for the latter half of the next century will make the task of sustainability infinitely easier.

*Work performed under the auspices of the U.S. Department of Energy by Lawrence Livermore National Laboratory under Contract No. W-7405-ENG-48.

Implications of Recent Tokamak Research for other Approaches to Toroidal Confinement

R.J. Goldston, Princeton Plasma Physics Laboratory

The last ten years have seen dramatic advances in experimental and theoretical tokamak research including:

- Experiments and theory demonstrating flow-shear stabilization
- Confirmation of current-drive power requirement scalings
- Confirmation of the predicted neoclassical bootstrap current
- Improved theoretical models for turbulent transport, including both “standard” regimes and internal transport barriers.
- Scaling of beta limits with shaping, R/a , and current profile (including the effect of “shear reversal”)
- Neoclassical effects on resistive island growth & suppression

While it has often been discussed that the impressive range of research on “alternate concept” devices sheds light on the physics of tokamaks, the thesis presented here is that the insights gleaned from the last decade of tokamak research can help illuminate physics issues for other approaches to toroidal confinement.

As a first example – perhaps furthest from the operating regime of tokamaks – recent work on flow-shear stabilization supports the hypothesis of Steinhauer *et al.* that flow shear may play a role in the mysterious stability of the field-reversed configuration. Interestingly, if “natural” flow scales like the diamagnetic velocity, this provides a “natural” FLR scaling for stability, since one would expect stabilization when the shearing rate approaches a fraction of the inverse Alfvén time. However this “FLR effect” is nonetheless very promising for a reactor, since for beta ~ 1 , driven flow at a fraction of the Alfvén speed becomes a practical possibility.

Recent results from the MST reversed field pinch and earlier results from the CTX spheromak suggest that favorable confinement can be achieved in RFPs and spheromaks, devices with high parallel current densities, if the radial profile of j_{\parallel}/B can be flattened. This suggests that external current drive may be a route to high performance in these devices. However, while the FRC current is largely self-sustaining through the diamagnetic effect, and the advanced tokamak current is largely self-sustaining through the recently confirmed bootstrap effect, the overall scaling of current-drive power divided by fusion power in a toroidal device has now been shown to scale as:

$$P_{cd} / P_{fus} \sim (1 - f_{bs} - f_{dia}) n \langle B / B_t \rangle / (I_p B_p^2 \beta_p^2)$$

This suggests that the success of the RFP and spheromak may rest, in principle, on developing efficient methods of current drive, such as helicity injection, which ergodize at most a small radial region of the plasma at a time.

The spherical torus (called “spherical tokamak” by some) is the closest cousin to the tokamak. Reactor concepts based on the ST extend experimental results from the advanced tokamak to the low-aspect ratio limit. Thus much of tokamak knowledge (and even lore) can be carried over to the ST. However the “advanced” ST may provide some physics advantages over the advanced tokamak. High bootstrap operation is attained without shear reversal – but theoretically ballooning modes and micro-instabilities can nonetheless be stabilized, with no sheared flow, or flow at only the diamagnetic level. The “touchiness” of the reversed shear tokamak seems to be associated with its zero-global-shear region, which

may thus be avoidable in ST's. The high edge shear in the ST provides easier stabilization of resistive wall modes, and the high edge q may be favorable for disruption suppression.

Attempts are underway to marry the stellarator and tokamak concepts. The small-aspect-ratio toroidal hybrid, SMARTH, concept, being studied at ORNL, moves to much lower aspect ratio than other optimized stellarators, and still provides orbit optimization via very large helical ripple, giving rise to quasi-omnigeneity in the sense of Cary and Shasharina. The rotational transform is provided by a large $l = 1$ helical component, peaked on axis, combined with externally driven current, so that a conventional tokamak q profile obtains over most of the radius, and a substantial equilibrium beta can be supported. The result is a device with $\sim 10x$ confinement improvement over the unoptimized configuration, stable to ballooning modes over almost all of the radial profile, with volume average beta of 6%.

Another approach, studied by Nührenberg and Garabedian, and more recently at PPPL, takes advantage of the fact that magnetic fields which are nearly toroidally symmetric in Boozer coordinates can provide significant rotational transform at low aspect ratio. This provides good orbit confinement in a symmetric system, which is then free to rotate toroidally, possibly providing shear flow for turbulence suppression. Furthermore, as beta increases these devices develop substantial positive bootstrap current which then permits less distorted modular coils, further from the plasma – key issues in stellarator reactor optimization.

Theoretical calculations indicate that these devices share the properties of reversed-shear advanced tokamaks, including a core region which is second-stable to ballooning modes. In tokamak experiments reversed shear regions, at high bootstrap current, are stable against resistive island growth. Theoretically this same property should be very valuable in a stellarator, in that islands which might otherwise grow in the equilibrium as beta increases should be strongly suppressed.

The presence of toroidally quasi-symmetric transform should allow the shear reversal point to be moved outwards to the edge of the plasma, again avoiding instabilities associated with $q' = 0$, by the opposite approach from the ST (q' would be everywhere negative in the stellarator case). The elimination of the edge current drive needed in the advanced tokamak and ST should both reduce the low- n kink drive, and also reduce the recirculating power requirement. Seed transform could be provided by the stellarator fields as well. External transform may eliminate or ameliorate disruptions; in W7-A rather modest amounts of external transform (~ 0.13) allowed non-disruptive operation even at $q(a) < 2$. The marriage of stellarator and advanced tokamak concepts in the quasi-axisymmetric, high-bootstrap stellarator may therefore offer compactness, good confinement, high beta, low recirculating power, stability, and relative simplicity – an attractive package if it is realizable.

In sum, the tokamak has been a very productive vehicle for learning high-temperature plasma physics. As embodied in the steady-state advanced tokamak, it may itself provide the physics concept for an attractive fusion reactor. However it also has provided a tremendous resource of physics knowledge for optimizing other approaches to toroidal confinement, one of which may ultimately prove to be the most attractive.

This work supported by US DOE Contract DE-AC02-76CH03073.

HIGH-BETA PULSED

STUDYING THE FEASIBILITY OF THERMONUCLEAR MAGNETIZED
PLASMA GENERATION
IN MAGNETIC IMPLOSION SYSTEM MAGO

A.M.Buyko, V.K.Chernyshev, V.A.Demidov, I.N.Dolin, S.F.Garanin,
V.A.Ivanov, V.P.Korchagin, M.V.Lartsev, V.I.Mamyshev, A.P.Mochalov,
V.N.Mokhov (presenting author), I.V.Morozov, N.N.Moskvichev, S.V.Pak,
E.S.Pavlovsky, S.V.Trusillo, G.I.Volkov, V.B.Yakubov, V.V.Zmushko

VNIIEF, Sarov, Nizhni Novgorod, Russia

Abstract

According to computations and estimations, in the MAGO system thermonuclear ignition can be achieved through compression of preliminarily heated DT gas with a shell accelerated by magnetic field. DT gas is heated in the MAGO gas chamber when magnetized gas flows through the nozzle. The flow occurs under action of forces appearing at increase in currents generated using EMG. Plasma capable to generate up to $(3-5)10^{13}$ neutrons per pulse has been recently obtained. To determine suitability of the generated plasma for further compression, of primary importance is small quantity of contaminants in DT gas and time of existence of more than 0.2-0.3 keV temperature plasma. Estimation of these parameters and creation of conditions necessary to obtain the desired characteristics are the main tasks of the joint VNIIEF-LANL experiments. In three conducted experiments diagnostic methods were verified and parameters of the obtained plasma were studied. Stability of obtained results, presence of hot plasma of microsecond lifetime is shown. The preliminary results allow to expect that the selected line of works is of significant future potential. It is being planned to complete the preliminarily heated plasma studies and study the feasibility of DT gas ignition at compression in the VNIIEF-LANL works under ISTC projects.

AFFORDABLE DEVELOPMENT OF FUSION USING MAGNETIZED TARGET FUSION

Kurt Schoenberg and Richard Siemon
Los Alamos National Laboratory

Controlled Thermonuclear Fusion has been a scientific grand challenge for the past 40 years. Despite enormous technical gains in hot plasma confinement, realization of an economic fusion energy sources remains a distant possibility. At issue is the development of "advanced" plasma confinement schemes and concomitant new materials that have an fordable development path and that project to a viable reactor for terrestrial power production. One such advanced concept uses the magnetically-driven compression of magnetized plasma to thermonuclear burn conditions. This approach, generically called Magnetized Target Fusion (MTF), presents unique "grand challenges" to plasma physics and fusion technology. An overview of this concept with a view to inherent physics, and energy production will be presented.

Fast heating of a dense plasma and prospects of $\beta \geq 1$ experiments at the GOL-3-II facility.

A.V.Arzhannikov, V.T.Astrelin, A.V.Burdakov, P.V.Denisenko,
V.S.Koidan, K.I.Mekler, P.I.Melnikov, V.V.Postupaev, A.F.Rovenskiikh,
S.L.Sinitsky.

Budker Institute of Nuclear Physics, 630090, Novosibirsk, Russia

Introduction. The fast heating of the dense plasma ($10^{15} - 10^{17} \text{ cm}^{-3}$) during the injection of a microsecond electron beam with an energy content over 100 kJ is being investigated at the GOL-3 facility. This is a crucial problem for the development of the pulsed multimirror thermonuclear reactor [1].

The first stage of the facility (length $\approx 7\text{m}$, beam energy content $< 100 \text{ kJ}$ [2]) had been successfully operated during six years. The main experimental results are the following.

- A high level (up to 25-30%) of the collisionless energy losses of the microsecond electron beam in a plasma with a density of $\sim 10^{15} \text{ cm}^{-3}$ was obtained and electron temperature of 1 keV was achieved .
- During intense interaction of the electron beam with a plasma, the longitudinal electron thermal conductivity was found to be 2-3 orders of magnitude lower than the classical one .
- The feasibility of heating a dense ($10^{16} - 10^{17} \text{ cm}^{-3}$) plasma with the electron beam by the "two-stage" scheme was demonstrated .
- A series of experiments on the interaction of a hot plasma and an electron stream with various solid targets was carried out. This is important for the choice of divertor material for ITER. The parameters of the "target" plasma and the surface erosion, which are strongly dependent on the incident energy density, have been studied .
- First experiments on generation of a high power ultraviolet "flash" from the dense plasma bunch with various elemental compositions have been performed .

In the middle of 1995 all experiments on the first stage of the GOL-3 facility were completed and the facility was partly decommissioned. By the end of 1995, the GOL-3-II facility was assembled and put into operation.

The GOL-3-II facility. The key improvements of the facility [3] are a substantial increase in the energy content of the electron beam injected into a plasma as well as substantial increase in the device length. In the new configuration the U-2 generator of the electron beam is used for plasma heating enabling to obtain electron beam with the energy content up to 0,3 MJ. The plasma column length on the GOL-3-II facility is 12m compared to 7m in the previous version. The energy content of the capacitor bank for the solenoid power supply system was increased from 10

to 15 MJ. This enables one to have the magnetic field of up to 5T in the homogeneous part and up to 10T in the end mirrors.

The main goal of the experiments on the GOL-3-II facility is obtaining the dense (10^{16} - 10^{17} cm^{-3}) and hot ($\sim 1\text{keV}$) plasma and achieving $\beta \geq 1$. Under these conditions, the experiments on the "wall" confinement of a plasma become feasible.

To obtain this goal the successive solution of several experimental problems is required: the production of a 12m long plasma column in magnetic field; the beam injection into the plasma and the beam transport through the entire length of the device; a search for the conditions of the efficient beam-plasma interaction, and then the heating of a dense plasma for attaining $\beta \geq 1$.

During the one and a half years of operation of the device some of these problems were solved experimentally. The main results of this stage are as follows.

Obtaining a 12-m long plasma column. The column of preliminary plasma with the density $\sim 10^{15}$ cm^{-3} and the length 12m was obtained in the metal vacuum chamber in the magnetic field of 4,5T [3].

Beam injection and its transportation. The injection and transportation of the beam of the 1MeV with the current of up to 40 kA and the duration up to 8 microseconds in the plasma with the length of 12m are performed. The method of the beam current compensation in a plasma for providing its macroscopic stability (suppression of the Kruskal-Shafranov instability) was found.

The experiments have shown that for the macroscopically stable beam transportation through a plasma of 10^{15} cm^{-3} density some special measures are required for obtaining full current neutralization of a beam and consequently, for suppressing the screw instability of the beam-plasma system. The high level of plasma turbulence occurred at the collective relaxation of an electron beam makes the plasma conductivity insufficient for the current compensation of a microsecond duration beam even at the plasma temperature of the order of 1 keV. As a result of the experiments the conditions were found out when no substantial macroscopic shifts of a beam across the magnetic field were observed [3].

Heating of the plasma uniform in length. A series of experiments have been performed on heating of the uniform (over the length) plasma. These experiments have been aimed to a search for the conditions optimal for the efficient energy transfer from beam to plasma and the measurement of the main parameters of hot plasma. To this aim, the beam was injected into solenoid with a magnetic field of 4,5T in its homogeneous part and the field of 9T in mirrors. The plasma density varied within the limits of $(1-5) \cdot 10^{15}$ cm^{-3} . It is shown that at $(1-3) \cdot 10^{15}$ cm^{-3} density the beam-plasma interaction efficiency and an energy store in a plasma does not practically depend on the density. With further increase in density the decrease in the hot plasma energy store is observed. At a

density of $(1-3) \cdot 10^{15} \text{cm}^{-3}$ the beam deceleration efficiency measured by the beam spectrum on the system output is 30-40%.

The measurement of the distribution function of plasma electrons by the laser scattering have shown that the characteristic mean energy of electrons ("temperature") is $\sim 1.5 \text{ keV}$ at a density of $\sim 10^{15} \text{ cm}^{-3}$. The anisotropy of the distribution function of hot plasma electrons is observed. The mean energy of particles traveling along the beam direction is few times higher than the transverse mean energy. The distribution functions of electrons in the process of heating is formed due to the turbulent fields excited in a plasma by the beam. The same fields leads to the abnormally high (compared to the classical) electron collision frequency, which in turn, to decrease the plasma thermal conductivity, and hence increases the temperature and lifetime of electrons. Under these experimental conditions, the ion temperature achieves 20-30 eV.

Prospects of obtaining plasma with $\beta \geq 1$. For the substantial increase of the ion temperature and for obtaining plasma with $\beta \geq 1$ the method of a two-stage heating of a dense plasma is being developed on the facility [4]. In this case in the background "rare" plasma which is heated directly by an electron beam due to collective interactions, a dense gas bunch (one or several) is formed by the pulse injection. As a result, the hot electrons of the "rare" plasma transfer their energy to electrons and ions of the dense bunch by pair collisions. The feasibility of such a method is already proved on the first stage of the GOL-3 facility.

New experiments in this direction also started on the GOL-3-II. To do so, in the beginning of the device the deuterium cloud few meters in length and density of $\sim 10^{16} \text{ cm}^{-3}$ is formed. On the rest of the device the density of the plasma is of $\sim 10^{15} \text{ cm}^{-3}$. In this case, the plasma with density $\sim 10^{16} \text{ cm}^{-3}$ has the electron temperature of 300-500 eV, and the ion temperature increases up to 100-200 eV.

In order to improve the parameters of a dense bunch it is planned not only to optimize the conditions of its heating but also to improve the bunch confinement. To this aim, it is planned to produce in the facility the short ($\sim 1\text{m}$) part with lower magnetic field ("magnetic pit") where a dense plasma will be confined similarly as in a "gasdynamic" trap. The experiments with colliding of two hot bunches are also planned. As the calculations show [5] under the conditions of the GOL-3-II facility it is possible to obtain a hot dense plasma ($\sim 1 \text{ keV}$) with $\beta \geq 1$. This will enable to start the experiments on the plasma "wall" confinement.

References

1. Ryutov D. D., Termojadernii sintez, No. 1, p.96 (1978). (in Russian) Chebotaev P.Z., Knyazev B.A., Koidan V.S., Kruglyakov E.P., Mirnov V.V., Ryutov D.D., Vekstein G.E. (this Meeting).
2. Burdakov A.V., Voropaev S.G., Koidan V.S. et al. JETP, 1996, vol.82, p.1120.

3. Agafonov M.A., Arzhannikov A.V., Astrelin V.T. et al. Plasma Physics and Controlled Fusion ,v38., N.12A., p. A93, 1996. Proc. of 23rd European Conf. on Controlled Fusion and Plasma Physics, Kiev, 1996, p.190.

4. Astrelin V.T., Burdakov A.V., V.S. Koidan et al. Proc. of 21th European Conf. on Contr. Fus. and Plasma Physics, Montpellier, Part 1, vol.18B, p.498-501, 1994.

5. V.T.Astrelin, A.V.Burdakov, V.V.Postupaev. 11th IEEE International, Pulsed Power Conference, Baltimore, Maryland USA, Abstracts, p.227,1997.

An Embodiment of the Magnetized Target Fusion Concept
in a Spherical Geometry with Stand-Off Drivers

Y. C. Francis Thio
Massey University at Albany
Private Bag 102-904, NSMC, Auckland 1310, New Zealand
Emilio Panarella
University of Tennessee
Knoxville, TN 37996-2100, U.S.A.

Ronald C. Kirkpatrick
Los Alamos National Laboratory
Los Alamos, NM 87545, USA

An innovative fusion scheme, embodying the principles of magnetized target fusion (MTF), in which the initial magnetized target and a plasma liner containing a cold fuel layer are introduced into the reactor vessel in a stand-off manner, is discussed.

Two compact toroids containing fusible materials are introduced into a spherical reactor vessel (typically no more than 25 cm in radius) in a diametrically opposing manner. Embedded in the compact toroids are magnetic fields in force-free Woltjer-Wells-Taylor's state of minimum energy (Wells et al. 1985, Taylor, 1974) and which are known experimentally to be extraordinarily stable. They collide in the center to form an initial magnetized central plasma, either in the form of a FRC or as two counter-rotating plasma rings. A spherical distribution of plasma jets are then launched from the periphery of the vessel, coalescing to form a spherically converging plasma liner. On impact with the central plasma, the plasma liner sends a shock wave through it, shock heating it to some elevated temperature (above 100 eV). The high temperature immediately raises the electrical conductivity of the plasma to the extent that it traps the magnetic flux inside the central plasma. The central plasma is further compressed by the plasma liner and heated near-adiabatically to conditions for thermonuclear burn, the magnetic flux being compressed with it. The compression is near adiabatic for two reasons: (1) the presence of the magnetic field strongly inhibits electron thermal conduction losses by several orders of magnitude, (2) the plasma density of the central plasma is kept relatively low so that bremsstrahlung losses are small. Synchrotron radiation losses can also be shown to be negligible. The thermal loss rate are sufficiently low that the compression heating can be achieved over relatively slowly using plasma jets with velocity of the order of 10 cm per microsecond, plasma velocities which have been achieved in the laboratory using electromagnetic acceleration ($\mathbf{J} \times \mathbf{B}$ forces). These are the principal features of magnetized target fusion (Lindermuth and Kirkpatrick, 1991).

In the scheme discussed, the plasma liner is a composite structure consisting of two layers, an inner layer carrying the main fusion fuel, and an outer tampering layer carrying a heavy gas such as argon. This composite structure can be formed either as part of the process of refuelling the plasma guns, or by a properly synchronized launch of two sets of spherically distributed plasma jets, each set carrying the required gas. The radial convergence of the plasma liner is halted abruptly by the nuclear burning central plasma sending a standing shock expanding outwards through the plasma liner, compressing the plasma liner to form a highly dense cold fuel layer on the inside. The cold fuel layer is ignited by the nuclear burning central plasma serving therefore as a hot-spot. The pressure and the inertia of the shocked and compressed liner provides the inertia confinement for itself and the nuclear burning hot spot. When the expanding shock wave reaches the outer boundary of the plasma liner, the liner expands and a rarefaction wave emanates radially inwards from the surface of this outer boundary. This results in the expansion and the disassembly of the plasma liner and terminates the confinement of the nuclear burning fireball. The fusion confinement time is approximately twice the transit time of an ion acoustic wave through the cold fuel layer. The cold fuel layer is sufficiently thick and dense to trap and re-deposit the energy of fusion produced charged particles, thus producing a burn wave spreading through the cold fuel. Because of the large amount of fuel mass available, a high fusion yield is obtained. Preliminary results show that gains of over 100 are possible, where gain is defined as the ratio of total fusion yield to the energy delivered to the hot spot. It is also noted that excessively high gain is not required here as plasma accelerators are relatively efficient.

An exemplary set of parameters follows. The reactor has a spherical cavity of 25 cm in radius. Plasma jets with entry velocity of 107 km/s and a mean density of 0.088 mg/cc are used to form the radially converging plasma liner with a total mass of 200 mg, providing 1.14 MJ of kinetic energy. An ensemble of 32 shaped coaxial railguns (4 guns per octant) is envisaged for producing the jets, with each gun launching a plasma slug of 6.25 mg and kinetic energy of 35 kJ. Plasma jets with these parameters have been routinely obtained in various types of plasma guns. In particular, using coaxial railguns, kinetic plasma jets can be produced in which the energy is predominantly kinetic rather than thermal.

The resulting plasma liner engages the central plasma at a radius of 2 cm. At this instant the central plasma is a D-T ball with a particle density of $6 \times 10^{23} \text{ m}^{-3}$. Compact toroids with this density has been routinely produced and accelerated in the laboratory (Wells et al., 1985; Degnan et al., 1993). The plasma ball is shock heated by the plasma liner to a temperature of 100 eV. Further compression of the plasma ball by the converging liner follows adiabatically down to a radius of 0.5 mm, at which point the plasma ball has a density of $3.8 \times 10^{28} \text{ m}^{-3}$ and a temperature of 10 keV, halting abruptly the advancing liner. A shock pressure of 1.2 Gbar is generated by this abrupt halting of the liner helping to contain the central plasma ball. Nuclear ignition and combustion occurs rapidly in the plasma ball, releasing approximately 286

MJ of fusion energy, corresponding to approximately a burn fraction of 10% of the DT mixture. The plasma liner is shock heated to an average temperature of about 560 eV, giving an ion acoustic wave speed of about 80 km/s. The shocked and compressed liner has a thickness of about 2 mm and disassembles in about 50 ns, which is approximately the confinement time for the nuclear burning fireball. The shock wave from the microexplosion causes a pressure pulse at the reactor wall of about 1 kbar. After thermal equilibrium, the average chamber pressure is about 2 kbar. These thermal conditions can be readily accommodated with appropriate reactor design.

REFERENCES

J. H. Degnan et al., Compact toroid formation, compression, and acceleration, *Phys. Fluids B*, Vol. 5 (8), pp. 2938 - 2958, (1993).

I. R. Lindermuth, R. C. Kirkpatrick, The promise of magnetized fuel: High gain in inertia confinement fusion, *Fusion Technology*, Vol. 20, pp. 829-833, 1991.

E. Panarella, The spherical pinch, *J. Fusion Energy*, 6, p. 285 (1987).

J. B. Taylor, *Phys. Rev. Lett*, Vol. 33, p. 1139 (1974).

TECHNOLOGY 1

The Future of Fission Reactors

by G. Kessler, D. Faude

Forschungszentrum Karlsruhe
Institut für Neutronenphysik und Reaktortechnik
P.O.Box 3640, D-76021 Karlsruhe

Present status

Development of nuclear fission reactors for power production started in the fifties with a plant output of several 10 MWe. Since then, the unit reactor size has been increased considerably, not least because of economic reasons. At present, and in the near future, the maximum power output of fission reactors for electricity production is in the range of 1300 to 1500 MWe. Some 440 nuclear power plants with a total output of 350 GWe are in operation worldwide now. The most common reactor type is the light water cooled and moderated reactor with enriched uranium fuel (LWR), which was originally developed for the propulsion of submarines.

Fission reactors for electricity production must compete against conventional power plants (hydroelectric, or fuelled with coal, oil or gas). The most aggressive competition is natural gas, used in combined cycle power plants that have relatively low investment costs and can be built in less than two years now. The environmental impact of fission reactors and their related fuel cycle is smaller than that of power plants with carbon fuel. Risk analyses of nuclear power plants and the comparison with other technical systems show that the risk during normal operation is negligible, and that also the accidental risk is by far lower than that of any other existing technical system.

Future fission reactors

The accidents of Three Mile Island (USA; 1979) and Chernobyl (former USSR, 1986), however, led the fission reactor community to reconsider the safety concepts of future reactors. At present, two alternative safety concepts are under development:

- small fission reactors with inherent safety characteristics which shall avoid reactor core meltdown,
- fission reactors of the same size as today which have such containment characteristics that even in case of a reactor core meltdown the radioactive release of fission products and actinides to the environment of the plant would be so low that emergency measures (e.g. evacuation or relocation of the surrounding population, or food ban measures) are not required.

Research and development work of the last ten years make this ambitious objective feasible in the near future.

Back-end of the fuel cycle

At present, there are two competing back-end fuel cycle concepts:

- direct disposal of spent fuel into a final repository. This concept requires about 40 to 50 years cooling time in intermediate spent fuel storage facilities with subsequent fuel conditioning for final disposal in the repository. This concept is followed e.g. by the USA, Sweden, and partially by Germany,
- reprocessing of spent fuel which means separation of the still valuable uranium and plutonium fuel from the high active waste (HAW), and

subsequent vitrification of the HAW. The vitrified HAW after further cooling over 40 to 50 years will then be disposed of in a final repository. This concept is followed in Europe with two large commercial reprocessing plants in La Hague, France, and Sellafield, UK, in which spent fuel is reprocessed also from Germany and Japan.

Both disposal concepts are considered in Europe as about equal under economic aspects. Whereas the direct spent fuel disposal route leads to an ever increasing accumulation of plutonium and other actinides in the final repository, the reprocessing route opens up additional options:

- multiple recycling of plutonium in Pu/U mixed oxide (MOX) fuelled reactors. This allows burning of more than 50 % of the Pu generated in LWRs,
- use of MOX fuel in fission breeder reactors. This allows burning of almost all U-238 (and Th-232) through the conversion (breeding) into plutonium (and U-233), and would thus assure energy generation with the presently known uranium and thorium ore reserves over many thousands of years. Fission breeder reactors were developed over more than 30 years and are being operated in Russia, France and Japan in power units up to 1200 MWe,
- new chemical reprocessing methods to be developed now which will allow reprocessing and partitioning of all actinides Np, Pu, Am, Cm, and long-lived fission products. In addition, Laser enriched methods can be used to separate isotopes of long-lived fission products.

These separated actinides and long-lived fission products can be burnt partially in existing LWRs. The burning efficiency will be better in specially tuned liquid metal reactors with fast neutrons. Even more efficient burning is expected from proton beam spallation facilities (accelerator driven transmutation systems, ADS), which could work in symbiosis with fission reactors.

The goal of reprocessing and transmutation techniques will be to minimize the present fission reactor waste problem. The HAW ingestion hazard could thus be decreased by several orders of magnitude, such that the contribution of long-lived actinides and fission products would only be in the range of naturally existing uranium ores with relatively high U concentrations.

Conclusions

Fission reactors have penetrated into the energy market and will have to compete in the short and medium time frame especially with gas and coal. Their health impacts through radioactive releases during normal operation are within the uncertainties of natural radiation. The risk of core meltdown accidents will be drastically reduced by new designs and safety concepts. In the long run, only the route of reprocessing and recycling of plutonium (or uranium-233) will open up options of burning uranium-238 (and thorium) - thus leading to energy supplies over thousands of years -, and of transmutating long-lived actinides and fission products - thus leading to a drastically improved waste concept for nuclear fission reactors.

Fusion-fission hybrid reactor research program in China

L. J. Qiu

Institute of Plasma Physics, Academia Sinica
P.O. Box 1126, Hefei, Anhui, 230031 P.R. China

The development of nuclear fusion as practical energy could provide great benefit to mankind, even big progress on many fusion devices has been achieved in the world and significant efforts are also made in the EDA of ITER as the next step towards the production of fusion energy. However, fusion energy as a commercial energy source is still decades away. The near term application of fusion power for VNS (Volumetric Neutron Source), in which the parameters requirements of core plasma are less stringent, would be advantageous to the eventual development of fusion power as well. Potential application of the tokamak neutron source are 1. Breeding fissile fuel for supporting fission reactor. 2. Transmutation of High Level Waste (HLW) from spent fuel of the fission reactor. 3. Volumetric Neutron Source (VNS) for radiation test of the fusion device components.

1. Viewpoint on the synergy of fission and fusion

Some reasonable predicted energy demand for China at 2050 year

Population	1.5 billion
Growth GNP/person	4000-8000 US\$
Total GNP	6000-12000 billion US \$
Energy demand	5 billion tons stan. coal/year
Capacity of electricity	1200-1500 GW

On the environmental impact of meeting such a requirement using fossil fuel, on the view that nuclear plants will be employed to meet new needs, and that the supply of fissile fuel and transmutation of spent fuel up and beyond 2050 in China will be insufficient.

2. Possibility of the development of a hybrid reactor program in China

A study has been conducted to determine the impact of fusion-fission hybrids on uranium demand and to identify the preferred hybrid concept from a resource standpoint. Several scenarios for U-Pu hybrids in the fission industry have been examined: scenarios

- I PWR(U)+PWR(Pu)
- II PWR(U)+FBR(M)+FBR(L)
- III PWR(U)+APWR+FBR(M)+FBR(L)
- IV PWR(U)+HTGR+FBR(M)+FBR(L)
- V PWR(U)+PWR(Pu)+HYB
- VI PWR(U)+PBR(M)+FBR(L)+HYB
- VII PWR(U)+APER+FBR(M)+FBR(L)+HYB
- VIII PWR(U)+HTGR+FBR(M)+FBR(L)+HYB

Here PWR(U) is a PWR burning uranium, PWR(Pu) is a PWR burning plutonium, APWR is an advanced PWR, HTGR is a high temperature gas cooled reactor, FBR(M) is a module fast breeding reactor, FBR(L) is a large fast breeding reactor, and HYB is a fusion-fission hybrid breeder reactor.

The study was done using the FCAC (Fuel Cycle Analyze Code) code. The results are very interesting.

The annual and cumulative uranium demands for the different scenarios are being examined.

3. Transmutation of HLW from spent fuel of the fission reactor.

Relative to previous fusion-fission hybrid reactor, our new concepts are based upon a small D+T fueled tokamak device (conventional or low aspect ratio tokamak) serving as strong neutron source in fusion power as little as 10-100MW to drive a HLW transmutation power plant.

The new blanket concept relies on the intense neutron flux to achieve a blanket energy multiplication of the order as 10-100

$$M = E_{\text{fission}} / E_{\text{fusion}} \cdot \kappa_{\text{eff}} / \nu(1 - \kappa_{\text{eff}})$$

where

κ_{eff} - critical factor

ν - mean number of neutron in fission process (~3)

$E_{fission}$ - energy release per fission (~200MeV)

E_{fusion} - energy release per D+T fusion (~14MeV)

When maintaining subcriticality κ_{eff} of up to 0.95, the intense thermal neutron flux ($>5 \cdot 10^{15} n \cdot cm^{-2} \cdot s^{-1}$) in the blanket ensures adequate neutron economy.

The analysis has been showed that the neutron wall loading can be lowered to the magnitude order of 1 MW/m² for the adequate transmutation capacity and efficiency. The neutronic analysis of blanket presented here put the conclusion forward. The neutron wall loading can be lowered even to the magnitude order of 0.5 MW/m² which is much easier to reach in the near future. It is also shown that the transmutation efficiency (fission/absorption ratio) is higher than the previous one. The blanket power density is about 200 MW/m² which is not difficult to deal with.

Table 1 The HLW transmuted after 500 days with nuclear wall loading 1Mw/m² and 0.5Mw/m²

	Am241	Am243	Cm244	Np237	Pu238	Pu239	Pu240	Pu241	Pu242
Nuclides	2910 ¹	360	-18	2250	-1107	1470	270	273	-99
Transmuted (1.e24)	3331 ²	404	-31.3*	2594	-1343*	1532	321	301	-129*
Number of LWR's** (Normalized to 1Gw.Year)	13 ¹ 14 ²	9 9	-2 -4	11 12	-18 -20	0.6 0.6	0.3 0.3	0.8 0.8	-0.5 -0.6
Transmuted fraction	11 ¹ 13.3 ²	7.8 9.12	-2.2 -3.9*	10 11.7	-358 -444*	12.9 15.3	5.1 6.22	16 17.5	-9.3 -12*

Notes: * negative value express the nuclide density increased.

** normalizing method: N=nuclides transmuted in 1 Gw.Year thermal power hybrid reactor blanket/nuclides produced in 1 Gw.Year thermal power LWRs

Table 2 Transmutation efficiency (Total fission reaction rate/(n,gamma) reaction rate)

	Am241		Am243		Cm244		Np237		Pu238		Pu239		Pu240		Pu241		Pu242	
0	1.0 ¹	1.1 ²	1.4	1.4	3.3	3.4	1.6	1.7	5.3	5.4	14.	14	5.0	5.2	12	11	4.6	4.7
500 days	1.0	1.1	1.4	1.5	3.4	3.5	1.6	1.7	5.3	5.5	14	15	5.1	5.3	11	12	4.7	4.8

Table 3 κ_{eff} , tritium breeding ratio and power density of the blanket

Time(days)	0	100	200	300	400	500
Keff	0.89 ¹ /0.97 ²	0.88/0.95	0.87/0.94	0.86/0.93	0.85/0.92	0.85/0.92
T	8.3/29	7.6/18	7.1/14	6.6/13	6.3/12	6.1/11
P(w/cm ²)	180/348	162/211	148/170	138/149	130/135	123/124

Notes:¹ for neutron wall loading 0.5 Mw/m², and

² for 1 Mw/m² in Table 2, 3, 4.

4. The low aspect ratio tokamak transmutation reactor

The low-A reactor core must be configured for full remote access for the critical components. The critical components include the "divertors", the first wall tiles, the transmutation blanket system, and the normal conducting center leg of the toroidal field coils. The features that can influence the low-A reactor core are summarized as Table 4.

Table 4 Parameter selection of low aspect ratio tokamak reactor core

Major radius R[m]	1.4	1.4
Minor radius a[m]	1	1

Plasma current I_p [MA]	12.54	8.7
Toroidal field B_t [T]	2.5	2.5
Plasma edge q	4.5	6.5
Average density $\langle n_e \rangle [10^{20} m^{-3}]$	1.6	1.1
Average temperature $\langle T \rangle$ [keV]	10	9.5
Plasma volume $[m^3]$	50	50
Bootstrap current fraction	0.54	0.4
Fusion power P_{fu} [MW]	100	50
Drive power P_d [MW]	40	50
Neutron wall loading P_w [MWm ⁻²]	1.02	0.5

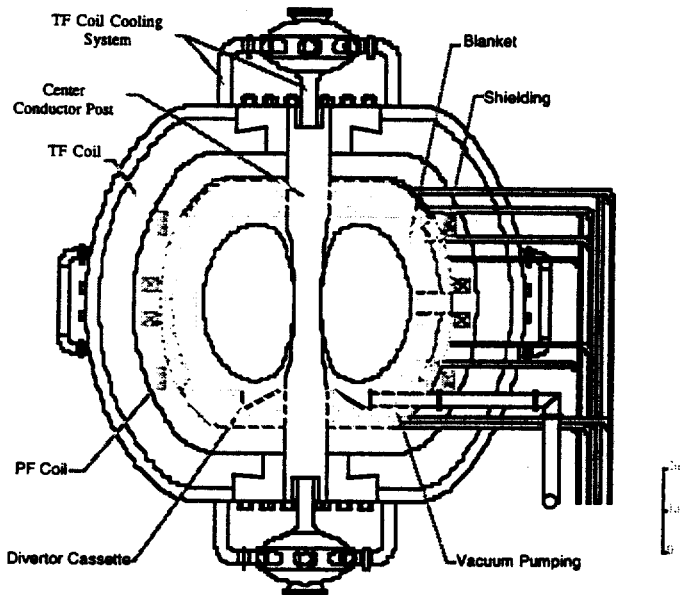

Fig.1 Schematic view of Hefei Low Aspect Ratio Tokamak Reactor(HLAR)

NUMERICAL STUDY OF DIRECT ENERGY CONVERTERS FOR A DEUTERIUM-HELIUM FRC FUSION REACTOR

Motoo Ishikawa, Tsukasa Kudo, Takashi Yamane
*Department of Electrical Engineering, Kyoto University,
Yoshida-Honmachi, Sakyo-ku, Kyoto 606-01, Japan*
and Yukihiro Tomita, Hiromu Momota

National Institute for Fusion Science, Shimoisi-cho 322-6, Toki 509-52, Japan

1. Introduction

The major portion of produced energy in $D-^3H_e$ fusion plasma will be released as the kinetic energy of charged particles. A conceptual design of the whole system of $D-^3H_e$ FRC fusion reactor was, then, carried out.^[1] As a part of the design, two kinds of direct energy conversion schemes have been proposed by H. Momota et al.^[2] One of them is a cusp type direct energy converter (CUSPDEC), which will separate electrons and fusion proton ions and also convert the kinetic energy of electrons and low energy thermal ions into the electricity, whereas another one is the travelling wave direct energy converter (TWDEC), which will convert the kinetic energy of fusion proton ions into high frequency AC electric power. The present report describes a numerical study of performance of TWDEC, of which basic parameters and generator configuration are taken from the conceptual design of the ARTEMIS-L reactor.^[1]

2. Self Excitation of Traveling Wave

The objective of this section is to show possibility of the self-excitation of the travelling wave through the grids within the converter and the external electric circuit and also to estimate the energy-conversion efficiency of TWDEC by using time-dependent one-dimensional calculations.

2.1 Basic configuration of TWDEC

The basic configuration of TWDEC is a cylinder with a radius of 5 m and consists of a modulator and decelerators. The initial velocity of fusion proton ions is estimated with its kinetic energy of 15 MeV, while the total energy input into the TWDEC is 272.5 MW. After a preliminary optimization, the following parameters are decided:

Total length of TWDEC	= 30 m,	Wave length of modulator (λ)	= 2π m,
Number of modulator grids	= 5,	Number of decelerator grids	= 25,
Length of modulator	= 2π m,	Length of decelerator	= $2.8 \times 2\pi$ m,
Frequency of travelling wave	= 8.54 MHz		

2.2 One-Dimensional Approximation

The configuration of FRC fusion reactor is a long cylinder which consists of a formation chamber, a burning chamber, and direct energy converters (CUSPDEC and TWDEC),^[1] and therefore the cylindrical coordinates (r - θ - z) are used in the present analysis.

The basic equations used in the one-dimensional analysis (in the z direction) are the momentum conservation equation of the fusion proton ions, Poisson's equation for the electric field including the space charge effect, and electric circuit equations of external control circuit.

The momentum equation is analytically solved within each numerical mesh.

Poisson's equation is solved with the Galerkin Finite Element Method (GFEM). The potential at the grids obtained with electric circuit equations becomes the boundary condition at the grids for Poisson's equation.

2.3 External Electric Circuit

Figure 1 illustrates the schematic diagram of the external electric circuit, where the displacement current at the grids is evaluated with the electric charge which is induced by the proton ion flow.

These electric circuit equations are solved with the fourth order Runge-Kutta method.

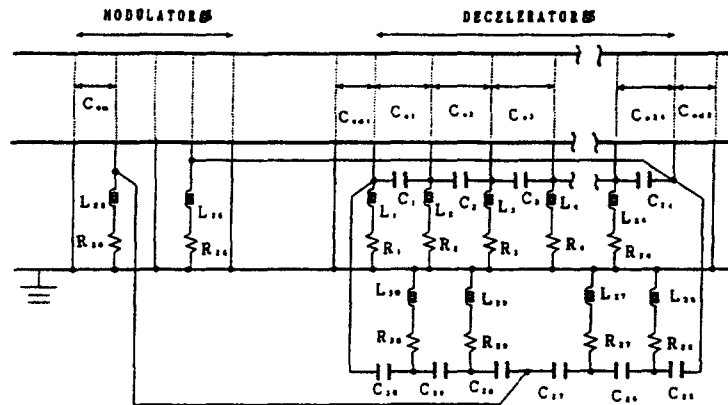

Fig.1 Schematic diagram of external electric circuit.

2.4 Formation of Autonomous Oscillation of Travelling Wave

It has turned out that the designed circuit can yield the autonomous oscillation (self-excitation) of the travelling wave. It takes about 800 periods of the wave, showing that the self-excitation is rather a slow physics process but also very fast (within 0.1 ms) from the engineering view point.

A preliminary optimization of the grid potential and the grid position has been carried out, showing that the maximum value of grid potential of 1.0 MV and the distance of 3.5λ between the last grid of modulator and the first grid of decelerator result in the maximum conversion efficiency of 70.9 %. According to this result, the configuration of TWDEC is fixed for the two-dimensional calculation.

Fourier analyses have been carried out to find the reason why the distance of 3.5λ between the last grid of modulator and the first grid of decelerator gives the maximum conversion efficiency, resulting in the following table.

Position	I_1	$\sum I_n$	Ratio	Efficiency (%)
2.0	1.11	2.32	2.10	59.2
2.5	1.19	1.89	1.59	65.3
3.0	1.21	1.55	1.28	67.4
3.5	1.17	1.35	1.15	70.9
4.0	1.08	1.25	1.16	68.8
4.5	0.93	1.12	1.21	60.3
5.0	0.73	1.19	1.62	50.0

In the table, "Position" stands for the relative position of the first grid of decelerator divided by λ , I_1 the ratio of fundamental wave component to the direct-current component, I_n the ratio of higher harmonics, and "Ratio" is $I_1 / \sum I_n$. As can be seen, the fundamental wave and higher harmonics has large effects and thus "Ratio" can play as an indicator of design. Then some detailed calculations have been carried out for the parameter of "Position" between 3.0 and 4.0, indicating that the maximum efficiency increases to 72.3 % at 3.8λ of the first grid of decelerator.

3. Collision Loss with Grids

3.1 Two-Dimensional Effects

Axisymmetric two-dimensional analyses on the r - z plane are carried out in order to estimate proton ions' collision loss with the grids, where the external electric circuits are not included, values of grid potential are given independently, which form the travelling wave with designed frequency, and the effect of magnetic field is included.

The basis equations are also the momentum equation of proton ions and Poisson's equation.

The r - z plane is divided by triangles and the momentum equation is solved analytically within the triangles. The θ -component of momentum of proton ions is also estimated.

Poisson's equation is solved with the Galerkin FEM with the first order triangular elements. Given values of grid potential play a role of the boundary condition.

We proposed a new cylindrical grid which is made of five co-axial, cooling-water circular pipes of one cm diameter. The ratio of open space for protons is 99.2 % for each grid.

It is shown that the effect of grids is small in the first half of channel but increases dramatically in the last quarter as the energy of protons is converted into the electric energy.

The maximum efficiency of 65.5 % has been obtained with the grid voltage of 1.7 MV when the collision loss with the grids is neglected. The potential decreases between the grids in the radial (r) direction, and, therefore, the effective potential reduces compared with the one-dimensional case, resulting in higher grid voltage required in the two-dimensional analyses.

3.2 Collision Loss with Grids

It is found that the maximum efficiency becomes 54.7 % with the grid voltage of 1.4 MV when the collision loss is included. It should be noticed that the proposed system includes total 32 grids and thus the simplest estimation of the conversion efficiency is $0.709 \cdot (0.992)^{32} = 0.548$. The two-dimensional result of efficiency of 54.7 % is, therefore, very good, although the two-dimensional effects look like rather large from the view point of ion trajectory and potential distribution. The optimum grid voltage decreases compared with the case of no collision loss, simply because the higher voltage enhances the two-dimensional effect and increases the collision of proton ions with the grids.

4. DC, AC Power Station

When the fusion reactor is considered as an electric power station, three kinds of electric power are produced: (1) AC power from a conventional thermal cycle, (2) low voltage DC power from the CUSPDEC, and (3) high voltage, high frequency AC power from the TWDEC. Thermal energy of the cooling water of the TWDEC can, thus, be transferred to the thermal cycle where more than 30 % of conversion efficiency into the electricity can be realized as the conventional steam Rankine cycle.

The overall gross efficiency of the TWDEC can be estimated as $54.7 + 45.3 \times 0.3 = 68.3$ %, which is very high compared with the conventional D-T reactors.

The frequency of AC power produced with the TWDEC is too high and therefore must be converted into DC power with some devices which must be studied in a near future. It should be noticed that the estimated voltage is adequate for DC transmission lines and the produced power can be easily transferred to existing large AC networks through DC transmission lines.

The low voltage DC power from the CUSPDEC must be converted into AC power through inversion systems, and then can be converted into the high voltage DC power which is transferred together with the power produced with the TWDEC, if required.

References

- [1] H. Momota et al., "D-³H_e Fueled FRC Reactor 'ARTEMIS-L'", Proc. 14th Int. Conf. Plasma Physics and Controlled Nuclear Fusion Research, IAEA-CN-56/G-13 (1992).
- [2] H. Momota, "Direct Energy Conversion of 15 MeV Fusion Protons", LA-11808-C, Los Alamos National Laboratory, pp.8-13 (1990).

FRC'S AND D-³He

Attractive Characteristics and Issues for developing Deuterium and Helium3 Fusion Reactor on the Base of a Field-Reversed Configuration

Hiromu Momota

National Institute for Fusion Science, Toki City, Gifu 509-52, Japan

For these decades, nuclear fusion researches have been developed toward D-T fusion which seems easier to ignite. Especially the tokamak concept demonstrated good confinement of plasma and has established the main line among approaches to a fusion reactor. Construction of "International Thermonuclear Experimental Reactor (ITER)" is scheduled on the bases of this concept, which is programmed to demonstrate controlled thermonuclear fusion. The estimated cost for constructing the device is, however, as expensive as 10 billion dollars. The heat load on the diverters is estimated as more than 20 MW/m², which is one order higher than the conventional technological limit. The high neutron flux of 10 MW/m² on the first wall of a commercial fusion reactor requires the development of structural materials, which are sound against neutron flux during 100 MWa/m². All of these problems are attributed to the 14 MeV neutrons from D(t, n)⁴He reactions. To avoid problems attributed to a large amount of neutron fluxes, neutron-lean fusion researches have been carried out [1].

The D-D fusion produces 2.45 MeV neutrons from the D(d, n)³He reaction as well as 14 MeV neutrons from the D(d, p)T(d, n)⁴He reactions. Since the branching ratio of the D(d, n)³He and D(d, p)T is 1/2, one assumes the 14 MeV neutron yields from D-D fusion to be one half of D-T fusion. The yielded fusion energy from the D-D reaction is, however, much smaller compared with that from D-T fusion and D-D fusion power plant is far from resolving above problems attributed to the neutrons. A unique solution to mitigate above engineering problems seems D-³He fusion. Fusion power carried by neutrons normalized by the total fusion power from D-³He fusion is as small as a few percents, this value has to be compared with 80% from D-T fusion or 30% from Cat. D-D fusion. Utilizations of other reactions such as ⁶Li(p, ³He)⁴He, ¹¹B(p, 2⁴He)⁴He, or ³He(³He, 2p)⁴He are unattractive because these reactions require extremely high ignition temperatures and consequent large radiation losses from these high temperature electrons prevent plasma from ignitions of fusion burning.

A conceptual design of a D-³He fueled commercial fusion reactor "ARTEMIS" [2, 3] was performed on the bases of a field-reversed configuration (FRC.) The design ARTEMIS described its attractive characteristics as a candidate of power plants :

1) The high beta value (= plasma pressure / magnetic pressure > 0.9) of an FRC and the application of highly efficient direct energy converters enables us to construct a cheap power plant.

ARTEMIS is a D-³He fueled fusion reactor with electric output power of 1,000 MWe and composed of a linear combination of the formation chamber, burning chamber, and direct energy converter systems at both ends. A cross-sectional drawing is exhibited in figure. The total length, the maximum radius, and the total weight are 160 m, 10 m, and 4,000 tons, respectively. Since a large volume of the direct energy converters is needed to keep the reliability, total volume of the vessel is comparable to a low-beta D-T reactor. The weight is, however, from several times to one order lighter compared with a conventional light water reactor or low-beta D-T reactors estimated from conceptual designs. A small amount of conventional materials allows us to construct the reactor system as cheap as 520 M\$ including the cost of 225 M\$ for the NBI heating system of 100 MW and 56 M\$ for magnetic systems. The estimated total direct cost and the plant capital cost are 1,030 M\$ and 1,800 M\$, respectively. The cost of electricity is calculated from the reactor by assuming 30 years for the reactor life, 3/4 for the load factor, and 8.56% for the interest during construction. The resultant cost is less than 30 mills/kWh which is cheaper by a factor 3 than the cost of electricity from contemporary power plants.

2) Because of its low neutron flux ($\sim 0.18 \text{ MW/m}^2$), conventional materials allow us to keep the structure sound during its whole life of 30 years.

The operation temperature of the burning plasma of ARTEMIS is chosen so as to minimize neutron yields. As plasma temperature increases, $\text{D-}^3\text{He}$ reaction increases, however, D-D reaction decreases and resultant neutron fraction in the total fusion power is as small as 3.2 % (power carried by neutrons is 56 MW and total fusion power is 1,757 MW) by operating plasma at the temperature of 83.5 keV. A higher plasma temperature increases radiation losses from the electrons and results in decrease of total fusion power. Since the first wall is 310 m^2 , the average neutron load on the first wall is 0.18 MW/m^2 . By a use of low activation ferritic steel (such as HT-9) that is estimated to be sound in a neutron fluence during 10 MWa/m^2 , the life of the first wall materials is 55 years which is much longer than the whole reactor life of 30 years.

3) Because of its low neutron yields, the reactor is intrinsically safe and environmentally acceptable in view of the disposal of radioactive waste.

The neutron yield in the reactor is 4×10^{19} neutrons/sec and tritium contained in the reactor is few grams. The ultimate public surface exposure in normal operation is 4 mSv for 50 years and occupational whole body exposure for 13 days is less than 2.0 Sv. These values are two to three order lower than the allowable limit. Because the reactor installs no breeding blanket, the plant is inherently safe even at a case of a loss of coolant accident. The total volume of disposed radioactive wastes after 30 years operation is approximately 460 m^3 and whose intruder dose is as low as 0.0024 mSv/years that allows us to apply a surface disposal.

There are several issues, on the contrary, for developing fusion reactor ARTEMIS. Typical issues are introduced below briefly.

1) Reliable production of initial FRC plasmas with low density and high temperature is inevitable.

In ARTEMIS design, low density of $4 \times 10^{20}/\text{m}^3$ and high electron temperature of 3 keV as the initial FRC plasma is required to develop the plasma up to the burning plasma with a neutral particle beam injection (NBI) heating of 100 MW. Those value have to be compared with values obtained from present experiments where the density is one order higher and electron temperature is one order lower. Since the needed heating power proportional to the plasma density and - 0.35 power of the electron temperature in our scaling, a formation of low-density FRC plasma is strongly required to heat a plasma with a reasonable heating power. The applied voltage of the power to the pinch coils in a formation chamber is as high as 400 kV. Development of initial plasma formation with relatively low voltage to pinch coils is preferable to keep reliability of the formation.

2) Physics understanding of plasma confinement in an FRC is still premature.

We employed Hoffman's scaling [4] for transports in an FRC, modified by multiplying the temperature following Kurtmullaev [5]. Anyway, studies on transports in an FRC are quite premature and theoretical studies on the transport are urgent to support or compare with experimental studies. Ultimately required energy confinement time for the reactor is 6.8 seconds.

3) Development of Lunar helium3 mining.

As was pointed out by Wittenberg *et.al.* [6], even celestial helium3 resources are available to the research and development of the fusion, the total amount of helium3 resources are too small to response world's energy demands in the 21 Century. Development of Lunar helium3 mining is, therefore, urgent to provide major energy to peoples in time.

4) Development of highly efficient direct energy converters is needed.

In ARTEMIS design, we introduced a novel direct energy converter system [7] composed of a cusp direct energy converter for separating electrons and recovering energy carried by leaked bulk ions and a traveling wave direct energy converter for recovering energy carried by 15 MeV fusion protons. In $\text{D-}^3\text{He}$ fueled fusion, more than 60% of fusion energy is carried by charged particles, therefore, obtaining a high efficiency of the converter is the key issue to obtain a high plant efficiency. The estimated overall efficiency of direct energy converter is approximately 70%

in ARTEMIS, whose high efficiency enables us to obtain a high plant efficiency and ultimately a low cost of electricity from ARTEMIS.

Above issues will be discussed partly by participants of the meeting. It has to be noted that one is able to obtain practically neutron free fusion or much cheaper electricity if one introduces a polarized D-³He fuels into an FRC. Those studies are also going on.

References

- [1] G.H.Miley, "Fusion Energy Conversion " Chapter 2 (American Nuclear Society, 1976)
- [2] H.Momota, A.Ishida, Y.Kohzaki, S.Ohi, M.Ohnishi, K.Sato, L.C.Steinbauer, Y.Tomita, and M.Tuszewski: Fusion Technology 21 (1992) 2307
- [3] H.Momota, O.Motojima, M.Okamoto, S.Sudo, Y.Tomita, S.Yamaguchi, A.Iiyoshi, M.Onozuka, M.Ohnishi, and C.Uenosono; *Proc. Seventh Int. Conf. on Emerging Nuclear Energy Systems*, Makuhari, Japan, 20-24 September 1993, p.16
- [4] A.L.Hoffman and J.T.Slough, Nucl. Fusion 26 (1986) 1693.
- [5] B.B.Bogdanov et al., Proc. 13th Int. Conf. Plasma Physics and Controlled Nucl. Fusion Research, Washington D.C., October 1990, IAEA, Vol.2 (1991) 739.
- [6] L.J.Wittenberg, J.F.Santarius, and G.L.Kulcinski, Fusion Technol. 10 (1986) 167.
- [7] H.Momota, LA-11808-C, Los Alamos National Laboratory, New Mexico, USA (1989) 8.

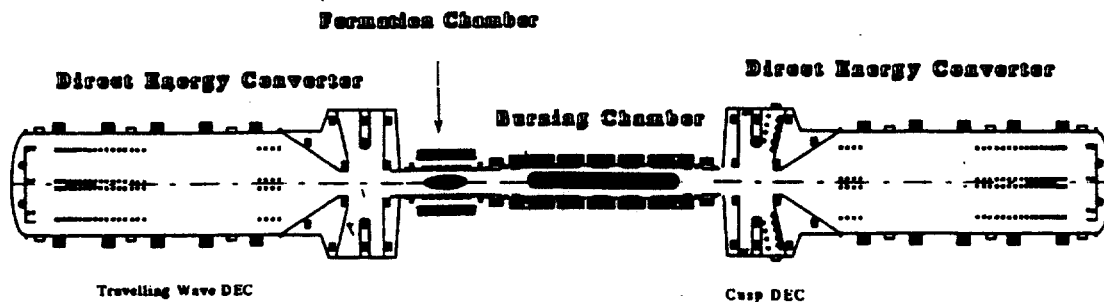

Fig. : A Cut view of D-3He Fueled FRC Reactor ARTEMIS-L

Flux Build-up in FRCs Using Rotating Magnetic Fields

Alan L. Hoffman and John T. Slough
University of Washington – RPPL

Rotating Magnetic Field (RMF) current drive is a very attractive method for both increasing the flux and sustaining the current in Field Reversed Configurations (FRC). It will be applied to a new Translation, Confinement, and Sustainment (TCS) experiment attached to the LSX/mod facility. FRC formation and sustainment through the application of RMF has been demonstrated in small scale rotamak experiments where the plasma temperatures and ionization levels were limited by the available RF power. This limited the axial confinement fields that could be utilized to about 100 G, and the rotating field strengths were generally of the same magnitude. Most previous RMF calculations have been performed for this range of conditions, and some of the restrictions derived for those parameters are changed when the poloidal confinement field exceeds the rotating field strength by several orders of magnitude. Also, most detailed two-fluid solutions were for steady state and ignored the flux build-up stage. In TCS, tens of MW of RMF power will be applied to a pre-existing FRC with kG level confinement fields. The ability of the RMF to increase the flux and sustain the plasma current of such an FRC will be of paramount importance in TCS and for an eventual reactor.

RMF current drive in plasma columns works by driving an azimuthal current through the application of a rotating field with direction and strength given by $\mathbf{B}_{\text{RMF}} = B_{\omega} \cos(\omega t) \mathbf{e}_x + B_{\omega} \sin(\omega t) \mathbf{e}_y$. The sense of RMF rotation is in the electron diamagnetic direction and opposite to the ion diamagnetic direction. It has generally been assumed that for RMF current drive to work, the frequency of the rotating field, ω , must lie in the range $\omega_{ci} \ll \omega \ll \omega_{ce}$, where $\omega_{ci} = eB_{\omega}/m_i$ is the ion cyclotron frequency with respect to the rotating field strength B_{ω} , and $\omega_{ce} = eB_{\omega}/m_e$ is the electron cyclotron frequency in the same field. The lower bound has been rationalized as necessary for the ions to remain stationary and not be 'tied' to the rotating field lines and cancel the electron current. Actually, under the above large axial field condition, neither the ions nor electrons are tied to the rotating field lines. Rather, an effective azimuthal EMF is created that tends to drive an azimuthal current as long as the RMF frequency exceeds the rotational frequency of the electrons. In a pre-existing FRC there is a net diamagnetic current corresponding to the configuration equilibrium. The RMF will only act to sustain this current when the total *fluid* electron azimuthal velocity is less than ωr . Any tendency for the ions to be driven in the rotating field direction will be deleterious to current drive.

The azimuthal drive term relevant to ions can be derived from either fluid or orbit calculations. Due to the moderate value of ω_{ci}/ω , and large axial confinement fields, it is actually not necessary that the ω_{ci} be $\ll \omega$. The ion drive term will be small when $\omega_{ci}/\omega \ll (2B_z/B_{\omega})$. The exact nature of the electron current will be a combination of both diamagnetic (∇p_e) plus $E_r B_z$ and $E_z B_r$ gyrocenter motion, with the exact electron orbits being of interest only with respect to transport. For high values of ω_{ce}/ω many types of orbits are possible and, in contrast to the ions, only the fluid equations are useful for examining the electron current drive. If the primary interest is flux build-up in pre-existing FRCs, then the quantity of interest is $\langle E_{\theta} \rangle$. In order to determine this, the fluid equations can be written in cylindrical geometry to conform with an axially uniform field structure and a cylindrical plasma. The magnetic and electric fields are given as:

Experimental Study on Translation and Confinement-Related Phenomena of an FRC Plasma

S.GOTO, S.OKADA, S.SUGIMOTO, M.OKUBO, H.HIMURA, and T.OHTSUKA

Plasma Physics Laboratory, Osaka University
Yamada-Oka 2-1, Suita, Osaka 565, JAPAN

Field-Reversed Configuration (FRC) has obtained a promising position as unique candidate for the Helium-3 fusion core plasma since the demonstration of the conceptual design reactor "ARTEMIS" (1). The point of view in the physics design is based on the following intrinsic ability of the FRC: extreme high β core, natural divertor around the core, and finally, shape or position control by some technique such as "translation" action. The high β nature relaxes the electron synchrotron loss, and the open-end divertor enables to mount a direct energy converter of 15 MeV fusion proton. The translation can give us various applications to overcome the reactor design problem and also to change the plasma parameters. In this paper, we present our study in the translation process and on some characteristics of the translocated and confined FRC plasma.

Experimental Scheme and Plasma Parameters ;

In our machine FIX at Osaka (2), the large volume FRC plasma can be contained in a stainless-steel vacuum vessel with a quasi-steady and long magnetic mirror field. It is, then, relatively easy to install the various kinds of fine instruments around the plasma. In the straight region between the mirrors the inner diameter of the vessel is 0.8m and the typical magnetic field is 0.05T. The mirror ratio is changeable from 2 to 10 and the typical ratio is chosen to be about 3. The contained plasma parameters in nominal experiment are also as follows ; $n_e \sim 5 \times 10^{19} m^{-3}$, $T_e + T_i \leq 200eV$, $r_s \leq 0.20m$ and $2l_s \sim 3m$. The FRC plasma with these unusual parameters can be obtained by translation technique. The FRC formation itself is made in the quartz tube of the inner diameter $\sim 0.28m$ by a standard inverse theta-pinch method, and this formation part is connected with an end of the metal vessel. The peak compression field with 1 T in the 1 m length produces the FRC plasma with $n_e \sim 5 \times 10^{21} m^{-3}$, $T_e + T_i \leq 400eV$, $r_s \leq 0.04m$ and $2l_s \leq 0.9m$. Just after the formation the plasma can be axially accelerated toward the confinement region by quick control of the magnetic field of a pair of driving coils attached at both ends of the compression coil. The plasma flies with a super-Alfvénic velocity $\sim 2 \times 10^5 m/s$ inside the confinement field which takes a role of a guiding field for plasma flight. After this first path, the plasma has bouncing motion of a few times and then can be contained between the mirrors (3). This is so-called "translation" process.

Dynamical Process in Translation (3) (4) (5) ;

It is unknown at the present time what kind of relation or scale between the initial formation and the final containment stages holds. Dynamical behaviors in the translation process is, instead, examined in our machine for several years. In very early phase where the FRC begins to move inside the compression coil, the axial trace of the rear edge movement of the FRC has been evaluated by interferometric and diamagnetic measurements with the aid of a numerical code. The acceleration in this phase is estimated to be around $0.2cm / \mu s \cdot \mu s$ and the velocity at the coil outlet is $4\sim 5cm / \mu s$. This acceleration may be caused by the magnetic pressure difference between the two driving coils. However, the axial velocity of the front edge and the midplane of the FRC already gets $20cm / \mu s$ at that time and reaches

$$\mathbf{B} = B_\omega \cos(\omega t - \theta) \mathbf{e}_r + B_\omega \sin(\omega t - \theta) \mathbf{e}_\theta + B_a \mathbf{e}_z \quad (1)$$

$$\mathbf{E} = E_r \mathbf{e}_r + E_\theta \mathbf{e}_\theta + \omega r B_\omega \cos(\omega t - \theta) \mathbf{e}_z \quad (2)$$

The axial electric field $E_z = \omega r B_r$ is produced by the time varying RMF.

The equation of motion for the electrons, using $\mathbf{j} = ne(\mathbf{v}_i - \mathbf{v}_e)$ and $\eta = m_e v_{ei}/ne^2$, can be written as a generalized Ohm's Law.

$$\mathbf{E} + \mathbf{v} \times \mathbf{B} = \eta \mathbf{j} + \frac{1}{ne} (\mathbf{j} \times \mathbf{B} - \nabla p_e) - \frac{m_e}{e} \left(\frac{d\mathbf{v}_e}{dt} + \frac{\mathbf{s}}{n} \mathbf{v}_e \right) \quad (3)$$

Averaging over an RMF cycle, the important quantity for sustaining the flux is

$$\langle E_\theta \rangle = \eta_\perp j_\theta + v_r B_z - \langle v_z B_r \rangle + \langle j_z B_r \rangle / ne \quad (4)$$

Since B_z is zero at the field null of an FRC, simple radial flow due to fueling cannot alone sustain the FRC flux. It is the coherent oscillation of j_z in phase with B_r that can produce positive values of $\langle E_\theta \rangle$.

Due to their small mass and high cyclotron frequency ω_{ce} , electrons will oscillate in phase with E_z and B_r , and produce an average azimuthal electric field of

$$\langle E_\theta \rangle \approx \frac{\omega_{ce}}{2v_{ei}} \left(1 - \frac{v_{e\theta}}{\omega r} \right) (\omega r B_\omega) + v_r B_z - \eta_\perp (-j_\theta) - \langle v_{iz} B_r \rangle \quad (5)$$

As long as the azimuthal electron fluid velocity is less than ωr the RMF current drive term can far exceed the ohmic loss term. In TCS 10s of kV/m RMF driven electric fields can be produced, while ohmic EMFs tend to be 10s of V/m.

Over most of the radius of an FRC $v_{e\theta}$ will be diamagnetic and be set by equilibrium constraints. However, in the outer layers $v_{e\theta}$ will be driven synchronous with the rotating field and can act to build-up or sustain the FRC flux. This allows RMF penetration, which should adjust to provide the necessary currents for equilibrium. This phenomenon has been observed in recent Australian rotamak experiments. For pre-formed FRCs the ultimate utility of the technique will depend on the power levels required to overcome the ohmic losses. For TCS this is estimated at between 3 and 30 MW depending on whether the effective resistivity at 100 eV is classical, or ten times classical. A RMF power supply is being built to provide this power level for up to 10 msec.

the inlet zone of the confinement where the magnetic field falls down to about 0.12T. Then, some conversion mechanism of the internal thermal energy to the directional energy may take part since the total temperature goes down to 60 eV from 400 eV in accord with this high velocity motion. The explanation for this could be done by the energy conversion of the plasma energy and the directional kinetic energy.

The recovery of the internal thermal energy can be attained on the first reflection of the FRC at the down-side mirror. This energy recovery can be caused in case of the super Alfvénic directional velocity. The detailed measurements so far reveals the recovery mechanism, which has been found to be a collisionless shock with rapid increase of the temperature. The second reflection occurs after that at the opposite mirror, where the additional energy increase does not take place but the plasma shape relaxes to the expected FRC. After these dynamics the large volume FRC keeps the quiescent phase over 0.3- 0.4 ms duration.

Core Plasma Confinement (6) (7) :

The nominal particle confinement scaling $\sim R^2 / \rho_i$ predicts $\tau_N = 30 \sim 40 \mu s$ for the parameters of our FIX-FRC plasma, but the experiment shows the better value of $\tau_N = 150 \sim 200 \mu s$ and $\tau_E \sim \tau_\phi = 100 \sim 120 \mu s$ with estimated anomaly about 10. Trial has been done to detect the density fluctuation by the Fraunhofer diffraction method with a CO_2 laser. The experimental fluctuation level is below the detection limit of $\bar{n}l / n_e \sim 1 \times 10^{-1} mm$ for $0.6 mm (\lambda < 60 mm$ and $f < 14 MHz$, where λ and f are the wavelength and the frequency of the fluctuation, and l is the thickness of the coherent wave zone of the laser input optics. The magnetic fluctuation has been also measured and gives the level of $\bar{B} / B \sim (1 \sim 10) \times 10^{-4}$ in the range of $1 \sim 10 MHz$. Note that the frequency of the LHD wave is predicted to be $6 \sim 7 MHz$ in our case with the drift parameter of 0.4 at the separatrix. Then the dominant anomaly is not thought to be caused by the LHD fluctuation.

Scraped-Off Plasma (8) (9) :

During the quiescent decay phase of the FIX-FRC, we have carried the measurements by many magnetic probes, interferometers, a polychromator and many electrostatic probes optically linked to the digitizer. The pressure and the density radial distributions just outside the separatrix is found to be exponent with the normalized thickness $\delta = 1.0 \sim 1.2$. The density and the electron temperature are $\sim 2 \times 10^{19} m^{-3}$ and $\sim 10 eV$, respectively, at $r_s + \delta$. The scraped plasma from the separatrix flows to the mirror throat. The flow velocity along the magnetic field is estimated to be $5 \times 10^3 m/s$ by the Mach probe measurement. At the mirror throat where the flow behaves like as the jet stream, our measurements indicate the parameters as follows; the center density $\sim 4 \times 10^{19} m^{-3}$, the jet velocity $\sim 5 \times 10^4 m/s$ and the jet radius $\sim 7 cm$. Then the particle loss rate from the mirror is estimated to be $\sim 7 \times 10^{22} / s$. On the other hand, the particle decay rate of the core plasma is $(5 \sim 10) \times 10^{22} / s$. Thus the loss measurement at the jet region is found to become a powerful tool for particle confinement study. We have also developed a novel particle energy analyzer to be capable of measuring the axial and the azimuthal velocity distribution. The average ion energy lost from the throat is $100 \sim 130 eV$ derived from the measurement by the analyzer. This corresponds to the convection ion energy loss of $(6 \sim 10) \times 10^5 J/s$, but this value is 3 to 5 times below that of the core plasma energy decay rate. This is quite different with the results discussed in other FRC confinement studies and so open to question.

References ;

- (1) H.Momota, A.Ishida, Y.Kohzaki, G.H.Miley, S.Ohi, M.Ohnishi, K.Sato, L. C. Steinhauer, Y.Tomita, and M.Tuszewski, *Fusion Technol.* **21**, 2307 (1992).
- (2) H.Himura, S.Okada, S.Sugimoto, and S.Goto, *Phys. Plasmas* **2**, 191 (1995).
- (3) H.Himura, S.Okada, and S.Goto, *Trans. Fusion Technol.* **27**, 345 (1995).
- (4) H.Himura, Y.Suzuki, Ueoka, H.Taniguchi, M.Okubo, S.Sugimoto, S.Okada, and S.Goto, in *Proceedings of the 1994 International Conference on Plasma Physics (ICPP, Iguacu Brazil, 31 Oct. - 4 Nov. 1994)*, Vol. 1, p. 169.
- (5) H.Himura, S.Ueoka, M.Hase, R.Yoshida, S.Okada, and S.Goto, in *Proceedings of the 1996 International Conference on Plasma Physics (ICPP, Nagoya Japan, 9 - 13 Sep. 1996)* Vol. 2, p. 1190.
- (6) S.Okada, S.Ueki, H.Himura, K.Matsumoto, D.Sadahiro, Y.Suzuki, K.Takahashi, F.Ichinose, M.Okubo, Y.Ueda, S.Sugimoto, S.Ohi, and S.Goto, in *Plasma Physics and Controlled Nuclear Fusion Research 1994 (International Atomic Energy Agency, Vienna, 1995)*, Vol. II, p. 441.
- (7) S.Okada, S.Ueki, H.Himura, and S.Goto, *Trans. Fusion Technol.* **27**, 341 (1995).
- (8) S.Goto, K.Matsumoto, H.Himura, D.Sadahiro, Y.Suzuki, M.Okubo, S.Sugimoto, and S. Okada, in *Proceedings of the 1994 International Conference on Plasma Physics (ICPP, Iguacu Brazil, 31 Oct. - 4 Nov. 1994)*, Vol. 1, p. 165.
- (9) M.Okubo, A.Ozaki, S.Okada, and S.Goto, in *Proceedings of the 1996 International Conference on Plasma Physics (ICPP, Nagoya Japan, 9 - 13 Sep. 1996)*, Vol. 2, p. 1186.

SELF-ORGANIZED COMPACT TORUS AS APPROACH TO LOW-SCALE FUSION SYSTEM WITH ONE-STEP SHOCK IGNITION

Rustam Kh. Kurtmullaev

State Research Center "TRINITI", Troitsk, 142092, Russia

The Programming Compact Torus (PCT) conception was proposed in 70's as an alternative to conventional pinch systems, with new approaches directed against fundamental difficulties discovered on the way of compressionally heated high β plasmas application to fusion purposes.

The experimental design includes (1-3):

- multi-element solenoidal systems with programming θ -currents to forming the elongated axially symmetrical antiparallel magnetic structure (AMS) and its guided evolution to Compact Torus (CT)
- axially canalized Z-current and impulsive / rotation multipoles replaced on side wall for magnetic insulation and radial distribution and losses control
- multi-chamber general design for separated procedures of CT formation, heating, translation, confinement (or additional compression by imploding solid liner)

The PCT scenario was tested in crucial experiments on TOR, TL, BN devices (TRINITI) (1) by parameters $B \sim 5\text{--}20$ kG, $n \sim (1\text{--}5) \times 10^{15}$ cm⁻³, $T_e \sim 0,1\text{--}0,5$ keV, $T_i \sim 0,1\text{--}3$ keV.

The physical essence of PCT scenario:

1. Controlling formation of elongated AMS and forced nontearing connection of its ends
2. Slow AMS energy accumulation and forced switch on of shock axial contraction based on specific MGD feature of balloon shaped CT.
3. Adjustment of Self-Organization Mode of the total relaxation, that gives simultaneously:
 - fast plasma flows acceleration (up to $V_z \sim 10^8$ cm/s) by means encounter MGD stable and lossfree poloidal pistons
 - impulsive initiation ($\tau \sim 10^{-6}$ s) of anomalous viscosity, plasma flows thermalization and, as consequence of plasma pressure jump, - the axial contraction stopping
 - sharp transformation of low $\langle \beta \rangle$ AMS into equilibrium high $\langle \beta \rangle$ CT with arbitrary structure (balloon shaped racetrack, ellipse or spheroid)
 - dominant ion heating with scaling $T_i \sim B^2$ without any saturation signs in studied range 0,1-3 keV. It is physical base to one-step shock achievement the fusion temperature in slow rise fields near the 30-50 kG.
4. Losses and instabilities damping and tearing-merging effects control both in dynamic and stationary phases founded on balloon shaping, inner "double currents ring"

structure, plasma flows affect and toroidal field influence (4). The special interest represents a long lived ($\tau \sim 10^2 \mu s$) sheared plasma flows in stationary confined CT (3).

5. CT translation and transforming of configuration by programming multi-coil system and AMS shaping, that gives the variation of directed / thermal energy attention $E_{kin} / E_{th} \sim 0-10$ and configuration ellipticity $t = l_s / 2r_s \sim 1-5$.

The consequences for experimental technics and innovations in fusion technology.

In technical aspects the PCT approach represents some alternative solutions on the way of extreme plasma parameters achievement:

- an "inner" magnetic storage facility for slow energy accumulation (based on azimuthal plasma current in start state AMS) and self-controlled fast trigger system for direct energy conversion in plasma heat or acceleration (based on current profiling only, without external high voltage technics).
- Many-chamber design of PCT facility giving the innovative versions for magnetic trap formation, plasma heating up to ignition, stationary burning state sustainment, plasma and closed magnetic flux refueling.
- Axially symmetrical magnetic structure with axial open flux around CT and programming exits devices represent simplest natural system for both plasma cleaning from impurities and fusion charged particles transportation for energy conversion, etc.

The PCT next step conceptual and experimental design.

It based on asymmetrically shaped cone AMS (5) and gives equally with shock heating, stabilization and loss damping also the new attractive feature: Self organization final state with arbitrary expanded radial size r_s by conservation of final separatrix volume, maximum postshock energy density and temperatures. This approach, uses only cone AMS axial contraction and stable overcritical balloon phenomena (1,5) means an simplest and chippiest way to increasing the system life time $\tau \sim r_s^2$.

The recent crucial experiment on TL-cone device (5) confirms such kind production mirror fields supported large radius ($X_s = r_s / r_c \sim 0,9$), relative short ($\epsilon \sim 2$) CT in continuous process of axial compression and relaxation, without any disruptive effects.

The paper contains the data for next step experiment project founded on combination of two encounter cone AMS systems and central stationary mirror trap, supporting the final CT configuration with double balloon shaping and "double current ring" inner structure, that is attractive because of its controlling stability features. This installation, named "Double Star", will have 40 cm diameter confinement region with shock heated in $T_i \sim 10...100$ keV range plasma by fields $B \sim 30-50$ kG, excited by MJ's level energy source, corresponds to TOR installation data.

The "Double Star" program main aims:

- 1) Study of high beta plasmas fundamental physics, including life time scaling near the fusion temperatures range
- 2) Conceptual modeling of fusion design tasks including advanced fuel problems.

The report concerns also to possible applications of PCT advances in solid liner compressed high energy dense CT approach (1,2) as well as in present programs used dense CT and shaped intensive plasma flows.

References:

- (1) R.Kh.Kurtmullaev, et al., "Compact Torus", Results of Science and Technology, Plasma Physics Ser., Vol. 7, VINITI Publ. House, Moscow, p.80 (1985).
- (2) A.G.Eskov, et al., in Proc. 10th Eur. Conf. for Contr. Fusion and Plasma Phys., 319, Moscow, 1981; A.G.Eskov et al., Sov. Tech., Phys. Lett (1983) 38.
- (3) B.B.Bogdanov, et al., in Plasma Phys. and Contr. Nuclear Fusion Research, 13th Conf., Washington, Proc. Vol. 2, IAEA 739 (1991); B.B.Bogdanov, et al., 12th Conf., Nice, Proc. Vol. 2, IAEA 527 (1989).
- (4) A.P.Kreshchuk, R.Kh.Kurtmullaev, Report 9D01 on Intern. Conf. on Plasma Phys., Nagoya, Japan, 1996.
- (5) R.Kh.Kurtmullaev, Report on Intern. Workshop on Physics Bases for D-He3 Fusion, Niigata, Japan, 1996 A.G.Eskov, et al., Report on the same Workshop.

TECHNOLOGY 2

AXISYMMETRICAL GAS DYNAMIC TRAP AS A HIGH POWER 14 MeV
NEUTRON SOURCE.
MODERN VERSION

A.A.Ivanov, E.P.Kruglyakov, Yu.A.Tsidulko, V.I.Volosov (Budker Institute of Nuclear Physics, Novosibirsk)
V.G.Krasnoperov (Efremov Institute, St.Petersburg),
A.V.Andriyash (Institute of Technical Physics, Snezhinsk)
H.Kumpf, K.Noak (FZ Rossendorf, Dresden, Germany),
B.Robouch (ENEA Frascati, Italy)

Gas dynamic trap (GDT) is one of the alternative candidates on the role of fusion reactor. However, due to specific peculiarities of this trap a relatively inexpensive neutron source for fusion materials testing can be built as an intermediate step on the way to reactor.

The importance of the development of powerful 14 MeV neutron sources is now well understood. The main reason is that existing nuclear technology data bases are not sufficient to design and construct the fusion power plant of any kind. One of the most attractive scheme of a 14 MeV neutron source was proposed by D.Ryutov with coworkers. This approach requires rather small tritium consumption (of the order of 100 - 150 g/yr), moderate electric power consumption (50 - 60 MW). At the same time the GDT based neutron source makes it possible to provide high flux of 14 MeV neutrons (of the order of 2 MW per square meter) on an area of the order of one square meter. By increasing the tritium and power consumption one can increase by several times the area of the testing zone. Since the time of the first proposal a lot of work was done on the optimization of plasma and all the system parameters. In particular, as analysis shows the magnetic field in mirrors can be decreased from 26 T down to the value of 13 T. Thus, in this case, fully superconducting magnetic system can be applied. Secondly, the plasma parameters were revised using a self-consistent numerical model which, in particular, in contrast to that initially used, takes into account the collisions between the fast ions.

It was shown that the problem of shielding the superconducting coils from neutron fluxes can be solved in principle. Due to the fact that 14 MeV neutron fluxes distributed along the axis of the system strongly inhomogeneously (maximum value of the flux achieves in the vicinities of turning points) neutral beam injectors operate under simpler conditions than those in the case of other plasma sources proposed so far.

It should be noted that the main plasma parameters required in the mentioned above neutron source are close enough to those achieved earlier in different mirror machines.

The development of the GDT NS concept is supported by experiments on the GDT acting model. At present, a full scale model (from the physical viewpoint) of such a neutron source (so called "Hydrogen Prototype") is

under construction in the Budker Institute of Nuclear Physics. The main parameters of this facility should be close enough to those in the GDT based neutron source. But the hydrogen prototype will operate without tritium. That strongly simplifies the shielding problems.

Synergistic Use of Liquid Lithium as Self-protecting First Wall, Tritium Breeder, and LMMHD Electric Power Producer*

Robert D. Woolley

Princeton Plasma Physics Laboratory
Princeton University, Princeton, NJ 08543

Two new ideas[†] are presented for fusion-related technologies, together intended to improve fusion economics and thus the likelihood that present fusion research will eventually return big payoffs in energy production. The first concept is a method/apparatus to produce and maintain a thick, flowing, liquid lithium layer which almost completely encloses a toroidal magnetically confined plasma, thus forming a renewable liquid first wall capable of high heat flux operation as the plasma-facing surface. To extract all of the DT fusion power and achieve tritium breeding self-sufficiency, a natural liquid lithium blanket must be about one meter thick. Conventional "balance-of-plant" designs convert the extracted thermal power to electricity via a rotating (e.g., steam) turbine, a rotating electric generator, and various massive heat exchangers. An alternative approach is to directly generate "liquid metal magnetohydrodynamic" (LMMHD) electric power using a two-phase combination of hot liquid lithium and helium bubbles (injected and extracted within the power conversion loop) for the working fluid. This concept has been studied extensively in the past, and has previously been suggested for fusion reactors^{1,2}. The second concept advanced herein locates such a lithium/helium LMMHD power generation system within the blanket region of a fusion reactor and directly integrates it with the blanket, in order to use the plasma's confining toroidal field magnet as the LMMHD power production magnet, and to reduce heat exchanger requirements.

Both of these ideas rely on the high electrical conductivity of liquid lithium; neither could work properly if the liquid lithium were replaced by an alternative nonconductive lithium-bearing liquid such as "FLiBe".

In the first concept, two separate, thick, axisymmetric "first wall" streams of liquid lithium are continuously injected into the top of a toroidal chamber containing a magnetically confined DT plasma undergoing thermonuclear fusion. Under the combined influence of gravity and electromagnetic forces, the two streams move along the "inboard" and "outboard" chamber walls to the bottom of the chamber, where they join each other before exiting through apertures provided for that purpose. The streams are held away from the plasma by poloidal electrical currents injected into the lithium through electrodes straddling a toroidally continuous upper poloidal insulating break which separates the injected streams and removed through electrodes straddling a toroidally continuous lower insulating break. The streams' poloidal electrical currents are thus driven in the same direction as currents in the nearby toroidal field magnet coils which enclose and link the toroidal chamber, so that in essence the streams together form an additional inner conductor winding "turn" for the toroidal field magnet coils. This configuration results in electromagnetic $\mathbf{J} \times \mathbf{B}$ forces which firmly push the liquid lithium of both streams against the chamber walls and thus hold it away from the plasma. The liquid's transit time from the top to the bottom of the chamber is determined by gravity, frictional losses and chamber geometry. Optional fixed irregular solid structures mounted on the chamber walls may also slow the lithium's rate of descent via induced eddy currents, if required by thermal design constraints.

In a variation on the first concept, a two-pass design using sublayers also is possible in order to simultaneously achieve high exit temperature of the heated lithium while keeping the maximum vapor pressure of the colder plasma-facing liquid lithium surface low. This useful capability to obtain a higher temperature inside a heated fluid than at its edge is unique to the first concept. It occurs since most lithium blanket heating is due to DT neutron interactions within the bulk fluid,

the sublayer with an open surface transits through the chamber faster than layers closer to the chamber wall, and because typical liquid lithium flow fields in a strong magnetic field are laminar rather than turbulent thus equilibrating slowly via thermal diffusion.

In the second concept, the basic LMMHD electrical power conversion loop is not topologically modified from LMMHD systems studied in the past. However, the physical shapes of LMMHD components are designed to physically fit inside the available space, which is limited to a radially thin band located just outboard of the toroidal plasma chamber extending toroidally around the chamber. This leads naturally to the use of flow ducts having a cylindrically axisymmetric shape which reduces MHD pumping losses.

The LMMHD scheme would function as follows: Hot liquid lithium at very low pressure emerges from the fusion blanket region of high intensity DT neutron heating at the bottom of the toroidal chamber. It then flows into a closed vertical, axisymmetric and toroidally continuous "MHD pump" duct located at a larger radius. A "radial" electric current perpendicular to both the flow and to the toroidal field is driven through the liquid lithium in this "MHD pump" duct via axisymmetric electrodes mounted on the inner and outer duct walls, thus producing a $\mathbf{J} \times \mathbf{B}$ force density which both propels the flowing liquid upwards and increases its pressure. The back emf voltage drop resulting from the induced $\mathbf{v} \times \mathbf{B}$ electric field absorbs externally applied electric power to perform the mechanical pumping action. At the high pressure top, small bubbles of highly pressurized helium gas are injected into the liquid lithium and are entrained in the fluid stream as it subsequently descends in an adjacent vertical "MHD generator" duct located at a slightly larger radius. Similar electrodes on the walls of this outer duct pass the same current through the lithium, thus restraining the fluid motion and causing fluid pressure to fall. The helium bubbles expand (and cool) as the pressure falls, which reduces the average fluid density and thus accelerates the fluid. With the oppositely directed but larger magnitude velocity, the forward emf voltage rise from the higher induced $\mathbf{v} \times \mathbf{B}$ electric field in this "MHD generator" duct generates more power than is consumed in the "MHD pump" duct. Net power is available as a direct current electrical output. Helium bubbles are separated from the low pressure lithium and the waste heat content of the helium is rejected into an external heat exchanger. The helium is then recompressed via a mechanical pump and sent back to the mixer region. The cooled liquid lithium is pumped back to the blanket region to be reheated.

Although LMMHD electrical power generation using a combined lithium/helium two-phase working fluid for thermodynamic energy conversion has been studied in the past as a simple and robust method for efficiently producing electrical power from a heat source, its projected capital costs contributed to inhibiting its further development. Those costs included the separate LMMHD power conversion electromagnets as well as the massive heat exchangers needed to transfer the heat into the liquid lithium. But this second concept relies on neutron heating to directly heat the liquid lithium, and utilizes the ambient toroidal magnetic field which necessarily exists in the blanket region for magnetic plasma confinement reasons. In addition to the reduction of heat exchangers and elimination of the need for turbines and electrical generators, advantages of the second concept include a reduction in the number of types of possibly interacting materials in a fusion reactor, thus improving safety and perhaps reliability. The fusion blanket tritium breeding material, lithium is the same material which is used for the thermodynamic energy conversion working fluid. Even the helium component of the energy conversion fluid matches the helium produced in the lithium as a byproduct of tritium production.

A concrete numerical example illustrating the two ideas in a single fusion device is described.

* Work supported by DOE Contract DE-AC02-76-CH03073

† Patent disclosures filed

References

- (1) W. Amend and M. Petrick, "Performance of an Efficient 'Low Temperature' Liquid-Metal MHD Power Cycle Suitable for Large Scale Power Production", Proc. 5th Intern. Conf MHD Electric Power Generation, Munich, 1971 (1971)
- (2) M. Petrick et al, "Liquid Metal MHD Energy-Conversion Systems: Concept, Applications, Status", February 1981, Argonne National Laboratory internal document

Linear induction accelerator for charge-neutralized ion beams in inertial confinement fusion

Ya. B. Fainberg, V. I. Karas', E. A. Komilov, Yu. S. Sigov*, N.G. Belova**, V.D. Levchenko'

NSC «Kharkov Institute of Physics & Technology»

** M. V. Keldysh Institute for Applied Mathematics of the Russian Academy of Sciences*

*** Institute of Physics & Technology of the Russian Academy of Sciences*

Abstract

In inertial controlled thermonuclear fusion using heavy-ion beams to "ignite" a target in the form of a pellet made from a D-T mixture inside a solid shell of diameter 0.3-0.4 cm it is necessary to deposit up to 10 MJ in a time of 20-25 ns, which is equivalent to a pulse power of 150-400 TW. The possible energy gain is estimated to be 80-100.

The development of accelerator facilities (drivers) for inertial confinement fusion using heavy-ion beams (referred to as HIF, for heavy-ion inertial fusion) has proceeded along two lines.

The first of these is the use of linear resonant accelerators with storage rings, and the second is the use of linear induction accelerators (linacs).

The great advantage of the first approach is the use of a fundamentally new accelerator, the ion injector (the Kapchinskii-Teplyakov system) with parameters 5 MeV, 200 mA, $\tau = 5 \mu\text{s}$, followed by linear resonant acceleration to high energies. A problem which is still unresolved is the design of heavy-ion accumulators that can be used to achieve a 10^5 -fold beam compression.

The important features of linacs are that they can operate at high pulse rate, accelerate practically any ions, have high efficiency, allow the beam energy to be increased continuously by adding to the modules, and give rise to space-time compression of a current pulse simply and naturally during the course of acceleration. Since the maximum potential drop in a linac is less than the potential applied to conductors connected in parallel (≈ 200 -500 kV) the very difficult problem of insulating the accelerator components as the energy acquired by an ion increases is no longer of concern. Since the acceleration process in a linac takes place over long distances, the density of the energy that must be stored in the system is significantly less than in other types of high-current accelerators. All of these advantages are apparent when we compare an ion induction linac with direct-acting high-current accelerators.

An induction accelerator driver has a uniform structure, consisting of identical accelerating sections which do not demand special high-power microwave generators.

The American heavy-ion ICF program is based on the use of vacuum ion induction linacs. In the initial stage of such an accelerator there are 64 beams with a current of 355 mA of cesium ions and a pulse length of several microseconds, accelerated in quadrupole lenses. The number of beams decreases as the energy increases. The final parameters of the driver are particle energy 18 GeV with a total energy of 10 MJ and a pulse length of 20-25 ns.

In contrast with a vacuum induction linac with a low injection current, it was proposed (1976) at the Kharkov Physico-Technical Institute to use an induction linac with neutralized ion beams having magnetically insulated accelerating gaps. In order to obtain a high-current ion beam (HCIB) it uses the collective focusing technique, in which the space-charge forces are neutralized by electrons, in contrast to the conventional methods for beam transport in vacuum (quadrupoles and solenoids). The electron current is suppressed by means of magnetic insulation of the accelerating gaps. Since the accelerated ion current in such an induction linac can amount to 10-20 kA, the requirements on the final ion energy are reduced and may be limited to a total energy of several hun-

dred MeV (instead of 10-20 GeV). Then it is no longer necessary to include storage facilities and multistep compression of the ion current pulse in the design. The longitudinal compression of the beam can presumably be reduced to a factor of five, with the final accelerating section being used for this purpose, fed by a voltage pulse of special form.

Preliminary estimates indicate that a device with 15 radially distributed accelerating modules, each of which supplies an ion beam with energy ≈ 300 MeV and current 100 kA and pulse length $\tau = 20$ ns to the target can be constructed, which yields a total energy of ≈ 9 MJ. Here it is assumed that the injector module and all the accelerating sections (except the last) will form a beam with current 20 kA and pulse length 100 ns.

At the present time there are three laboratories in the world which are developing the high-current inductive linac technology for inertial confinement fusion. These are the Institute of Laser Technology (Osaka, Japan), the Naval Research Laboratory (Washington, USA), and the Sandia Laboratory (Albuquerque, USA).

Induction linacs of this type, consisting of three to five sections, allow kiloampere ion beams with energies of order 1 MeV to be produced.

However, heavy-ion fusion (HIF) requires an increase in beam power and emissivity by several orders of magnitude. Consequently, the development of a driver for HIF based on a high-current induction accelerator involves the solution of several important physical problems. In the present paper we describe the results of our studies in the following areas:

- (1) the formation of HCIBs in an injector;
- (2) ensuring efficient magnetic insulation of the accelerating gaps;
- (3) charge and current neutralization of the beam in the transport channel;
- (4) efficient acceleration and stability of the beam in accelerating gaps; and
- (5) transport, focusing, and space-time compression of HCIBs.

In this report we have considered the formation of a high-current ion beam and its subsequent acceleration in an inductive linac consisting of an injector of gas or metallic ions and two induction sections with magnetically insulated accelerating gaps, yielding output parameters for the beam of 2-3 kA, 0.5 MeV, and 0.5 μ s. The linear and nonlinear theory of the filamentation of a high-current beam in a magnetized plasma has been presented. We have described experiments on filamentation of an ion beam in an induction linac. We have studied the effect of a transverse magnetic field on the high-frequency beam-plasma instability. We have described a nonlinear analytical theory of the charge neutralization of a high-current ion beam in a magnetically insulated accelerating gap. An appropriate mathematical model based on the particle method and a corresponding code based on solution of the Vlasov-Maxwell system of equations in a 2.5-dimensional geometry have been described.

Over the last six years, we have carried out systematic investigations of the propagation dynamics of relativistic electron beams and nonrelativistic ion beams in accelerating electric fields and axisymmetric nonuniform magnetic fields. The results obtained from studying the acceleration and the charge and current neutralization of hollow HCIBs in one or two cusps of a linac for various energies of the relativistic electron beams used to suppress the space charge of the ion beam are presented here. These results indicate that, in the presence and absence of accelerating electric fields, the charge and current of HCIBs in accelerating gaps can be neutralized by means of specially injected relativistic electron beams, and HCIBs are stable on a time scale that is substantially larger than the inverse ion Langmuir frequency and the ion gyrofrequency. Results from numerical simulations show that the charge neutralization of HCIBs by means of relativistic electron beams can be achieved only in accelerating gaps. In a transport channel between two accelerating gaps, the charge and current of the ion beams cannot be neutralized completely, because the velocities that the beam electrons and beam ions acquire before entering the transport channel are markedly different. As a result, the potential of the self-consistent field in the transport channel is positive, which leads to the deceleration

and spreading of an ion beam, and, consequently, to a decrease in the beam luminosity. In analyzing several methods of the injection of cold electrons into the transport channel we have shown that such a preliminary injection makes it possible to avoid the deceleration and spreading of an ion beam and to ensure its additional focusing. We tried to optimize the acceleration of ion beams by minimizing the undesired effect of a self-consistent potential field.

Here, we present the results of numerical simulations intended to find the optimum relationship between the parameters of the external electric field and the energy of the neutralizing electron beam, which must be such that the ion beam is efficiently accelerated, while remaining neutralized and stable.

Results of the combined experimental and theoretical study of the relation between the properties of an elastic pulse and the ion beam parameters have been presented. These show convincingly that it makes sense to use piezodiagnostics to determine the parameters of high-power ion beams.

Last investigations was aimed at studying the dynamics of "wide" beam propagation.

High-Power Explosive Magnetic Energy Sources for Thermonuclear Applications

V. K. Chernyshev

All-Russian Scientific Research Institute of Experimental Physics
607190, Sarov, Nizhni Novgorod region, Russia

Summary

High-power energy sources unavailable up to now are needed to carry out any one project on inertially confined controlled thermonuclear fusion (CTF). Considerable advances have been made in the area of explosive magnetic generators (EMG) as for their output characteristics (high-power combined with high energy content).

To evolve the concept of magnetic cumulation proposed by academician A. D. Sakharov in 1951 two new concepts to increase EMG fast-operation by two orders (from tens of microseconds to tenths of microseconds) were proposed at VNIIEF in the early sixties (fast operating disc EMG's and switches)

The concept (1972) aimed to solve CTF problem due to target magnetic compression (MAGO) under the effect of fast-increasing field was based on VNIIEF achievements, discussed (1976) at the USSR Academy of Sciences and published (1979).

The key physical questions are analysed, the problems to be solved are settled and the results achieved in the experiments with fast-operating high-power EMGs, fast-opening switches, transmitting lines are considered. The results obtained in the experiments on liner acceleration, as well as on preliminary plasma magnetization and heating, carried out at the constructed EMGs are discussed briefly.

The conclusion that MAGO system is the most suitable one to provide the ignition for the designing of high-power energy sources to be used in this system is practically completed and the concept itself does not need the intermediate transformations of one type of energy into another one always accompanied by the decrease of net efficiency is made.

Introduction

Feasibility of controlled thermonuclear fusion (CTF) is the most attractive problem in modern physics.

Even when high degree of sophistication and high level of scientific and technical reliability & safety are inherent in atomic power stations, considerable amounts of fission materials concentrated in space and time will always worry people from the viewpoint of possible extremist steps and wicked will of anomalous persons.

CTF will entirely eliminate these worries. In thermonuclear reactor fuel delivery is provided gradually and may be stopped at any instant. This is one among the important advantages of CTF.

Stationary systems with magnetic confinement, in particular ITER, are the most advanced in CTF area.

However the scope of works, time and cost necessary to create stationary systems are so high that the alternative "pulse" projects based on inertial confinement are worthy to more attention.

The MAGO concept providing two advantages is of prime interest:

- at the stage of SCIENTIFIC IGNITION the approach should not require innormous expenditures of about 1 billion dollars to construct energy sources usually needed to feed the lasers, ion beams, etc;
- at the stage of TECHNICAL IGNITION the approach should not require a great scope of works aimed to remount the cumbersome systems surrounding the chamber and providing its operation when replacing systems with the spent radiative capabilities (as in the case of ITER).

Ignition, to be sure, is the nearest principal goal of all inertial confinement projects. The most interesting physical studies providing extended data to answer the key questions may be carried out when approaching the ignition threshold.

On the scientific and technical break through three key fields of present-day physics

As a result of the intensive long-term studies the concept of ignition achieving based on MAGO experimental setup was developed.

Due to the activities carried out the unique experimental setup was brought into being and the scientific break through three key fields of present-day physics was made.

Physics of super-power sources

- fast-operating EMG of "Potok" family, having an output power of 10 TW and a stored energy of 10 MG, 100 MG or more, have been designed.

Physics of magnetized plasma.

- ionized magnetized DT plasma previously heated up to 0,2....1 keV has been produced, with a lifetime of 2 μsec and wherein $4 \cdot 10^{13}$ thermonuclear reactions have been performed.

Physics of high energy densities.

- the liner energy density of $>1\text{MJ/g}$ has been experimentally achieved, it was 200 times more than the explosive energy density;
- both calculations and experiments have proved that a quasispherical shell implosion is possible under the magnetic field having an axial symmetry.

Super-power energy sources. Results obtained with a ponderomotive assembly.

These are the results of the studies, which have been carried out:

<p>1. EMGs of "Potok" family are characterized by power output of $>10\text{TW}$, the energy introduced into the external load of $>10\text{MJ}$:</p>	<p>2. Ionised and magnetized plasma having a heating temperature of 0,2 - 1 keV has been produced in 1000 cm^3 volume. The lifetime was $\cong 2\ \mu\text{sec}$</p>	<p>3. The liner energy density of $> 1\ \text{MJ/g}$ has been experimentally achieved, it was 200 times more than the explosive energy density.</p>						
<p>1.1. Fast-operating helical EMGs:</p> <ul style="list-style-type: none"> •energy increase 200, 1000 •specific time 10...40 μsec •specific energy 100 J/cm^3 • energy output 0...40 MJ 	<p>2.1. The basic principles have been tested:</p> <ul style="list-style-type: none"> •plasma magnetization •generation of supermagnetosonic ion fluxes •preheating 	<p>3.1. Acceleration has been provided using magnetic fields of different liners. The following parameters have been achieved:</p> <table border="0"> <tr> <td>Mass</td> <td>Velocity</td> </tr> <tr> <td>1 g</td> <td>50 km/sec</td> </tr> <tr> <td>250 g</td> <td>15 km/sec</td> </tr> </table>	Mass	Velocity	1 g	50 km/sec	250 g	15 km/sec
Mass	Velocity							
1 g	50 km/sec							
250 g	15 km/sec							
<p>1.2. Fast-operating disk EMGs:</p> <ul style="list-style-type: none"> •energy increase 10...30 •specific time 5...12 μsec •specific energy 200...600 J/cm^3 •energy output 60...100 MJ 	<p>2.2. A stable production of 14MeV neutrons having $(3-5) \cdot 10^{13}$ n/pulse yield has been provided.</p>	<p>3.2. It has been proved that a quasispherical shell implosion is possible under the magnetic field having an axial symmetry.</p>						
<p>1.3. Fast-opening switches</p> <ul style="list-style-type: none"> •current 70...100 MA •specific time 1 μsec •voltage 500 kV 	<p>2.3. The shape and dimensions of hot zone(in centimeters) have been determined by photographing in its own neutrons.</p> <p>2.4. The lack of heavy ion admixtures from the walls has been experimentally shown.</p>							
<p>Conclusion: the energy sources are ready to provide the magnetized plasma preheating.</p>	<p>Conclusion: the magnetized preheated plasma is ready for subsequent compression.</p>	<p>Conclusion: the driver and the compression system are ready for compression experiments.</p>						

Thus, the work has come up to the culmination stage of studies, when the final phase, that is an adiabatic compression, is to be tested and the presence of the second temperature peak is to be ascertained.

MAGO ADVANTAGES.

- magnetized plasma application "locks up" electron and ion thermal conductivities, which enables ignition to be achieved at lower liner velocities and plasma compression level;
- to provide ignition, there is no need to build bulky expensive buildings and facilities costing hundreds of million dollars super-power EMGs. Already designed can serve as energy sources.

- there are no limitations preventing from the international collaboration on a large scale, since low ρ_0 and ρ_{\max}/ρ_0 , as well as the need for a magnetic field, make this work advantageously different from all those pertaining to ICF.

CONCLUSION.

The VNIIEF scientists and designers who have carried out all works described above are shure that MAGO is the quickest and the most cost-effective way in achieving the thermonuclear ignition.

REFERENCES

1. V.K.Chernyshev.
High-power explosive magnetic energy sources for thermonuclear and physical applications (overview).
Int.MEGAGAUSS-VII conf. Sarov, Russia, 1996
2. A.Buyko, G.Volkov, S.Garanin, V.Demidov, Yu.Dolin, V.Zmushko, V.Ivanov, V.Korchagin, M.Lartsev, V.Mamyshev, I.Morozov, N.Moskvichev, V.Mokhov, E.Pavlovskii, S.Pack, S.Trusilo, V.Chernyshev, V.Yakubov
Investigation of possibility of thermonuclear magnetized plasma in the system with magnetic implosion MAGO.
III Zababakhin Scientific Talks, Kyshtym, Russia, 14-17 Jan, 1992 Physics of High Energy Densities.
3. A.Buyko, G.Volkov, S.Garanin, V.Demidov, Yu.Dolin, V.Zmushko, V.Ivanov, V.Korchagin, M.Lartsev, V.Mamyshev, I.Morozov, N.Moskvichev, V.Mokhov, E.Pavlovskii, S.Pack, S.Trusilo, V.Chernyshev, V.Yakubov
Investigation of possibility of thermonuclear magnetized plasma in the system with magnetic implosion MAGO.
IX Int.Pulsed Power Conf. 21-23 Juune, USA, 1993

**DIPOLES AND
ELECTROSTATIC**

The Dipole Plasma Confinement Concept

Michael E. Mauel

Dept. of Applied Physics, Columbia University, New York, NY 10027 U.S.A.

Jay Kesner

Plasma Science and Fusion Center, MIT, Cambridge, MA 02139 U.S.A.

The dipole fusion concept was first proposed by Hasegawa (1) who was motivated by observations of high beta, energetic plasma within planetary magnetospheres (2). Plasma trapped within nature's magnetic dipoles often is driven *inward* to regions of higher magnetic field and higher plasma pressure due to low-frequency perturbations of geomagnetic and electric fields driven by solar variability and flows. Furthermore, active magnetospheres, such as that surrounding Jupiter, have plasma pressures exceeding the magnetic pressure, $\beta > 1$ (3). The dipole reactor takes advantage of these properties by operating with plasma profiles which are fundamentally "stationary" and "marginally stable" at high beta. By "stationary" we mean that low-frequency fluctuations, such as convective cells, do not lead to anomalous transport, and, by "marginally stable", we refer to the stability properties of these "stationary" profiles to interchange and ballooning modes when $\beta > 1$ (4). The dipole fusion reactor is different from other fusion concepts since it is the first plasma confinement conceived to eliminate *both* fast MHD plasma instabilities and anomalous plasma transport induced by low-frequency drift turbulence or velocity-space driven instabilities.

A dipole fusion reactor would consist of a single levitated circular magnet within a large vacuum chamber. The hot plasma core would encircle the levitated dipole coil forming a toroidal annulus. A large expansion region of cooler plasma extends outward from the dipole where the plasma pressure decreases with radius, L , approximately as $L^{-20/3}$ characteristic of the "stationary", "marginally stable" profiles found in magnetospheres. Although the overall dimensions of the dipole fusion reactor may be large, the size of superconducting dipole magnet is very small. Indeed, in the dipole reactor conceptual designs discussed below, the volume of the hot plasma core (40 m^3) exceeds the volume of the levitated ring (20 m^3). This feature of the dipole reactor (*i.e.* a larger plasma volume than the volume of the high-technology superconducting magnets, shield and structure) is in sharp contrast to the tokamak where the volume of the plasma is usually less than the volume of the surrounding fusion island. (For example, in ITER, the plasma volume is 2500 m^3 and the volume of the magnets, shield and structure exceeds 5000 m^3 .) The dipole reactor concept also differs from the spherator (5) since the plasma profiles of the spherator are steep (*i.e.* they cannot be made "stationary") and low-frequency fluctuations or convection cells significantly degrade confinement.

Conceptual dipole reactor designs have been reported (6, 7), and the use a dipole fusion reactor for space propulsion has been proposed (8). In each of these designs, $\text{D-}^3\text{He}$ fuel was used instead of the more highly reactive D-T fuel in order to reduce the neutron flux to the levitated dipole. Also reflectors were used to reduce synchrotron losses from the high-pressure

and lower β plasma on the inside of the levitated dipole. The high β capability of the dipole reactor makes possible the use of advanced and possibly aneutronic fuels, but the high temperatures required to burn these fuels necessitate steps to reduce synchrotron emission losses. The designs reported in Refs. 6 and 7 described compact, and relatively low-power dipole reactors with large plasma expansion regions. A 20 MA dipole radius of 1.8 m confined a plasma with peak $\beta \sim 3$ and generated 100 MW of fusion power. A higher field, 40 MA dipole with a denser plasma at the same β could generate 1000 MW. The plasma is heated to ignition with direct heating of the plasma core (using, for example, neutral beam injection) and the cooler plasma in the expansion region is populated with low-frequency drift-resonant instabilities. Axisymmetry insures confinement of energetic fusion products until after ignition when $m = 1$ magnetic perturbations can be applied to drift-pump protons and alphas into direct or thermal conversion sites at natural divertors. In Ref. 8, a much larger dipole reactor was considered with a 54 MA dipole having a radius of 6 m and producing 2000 MW of fusion power. A large plasma expansion region was not used since a relatively hot plasma was diverted to an annular gas-neutralizer to generate thrust. In both Refs. 7 and 8, thermoelectric converters were located within the levitated dipole, and they provided the power to drive refrigerators for the superconducting magnets. Designs of the superconducting magnets and shields in Refs. 6 and 8 illustrate the feasibility of reactor-sized dipole magnets using present-day multi-filamentary Nb_3Sn conductors.

The physics basis for dipole plasma confinement and stability has been advanced by recent theoretical and experimental efforts. Pastukhov and Sokolov have shown that the intensity of drift instabilities driven by the inward temperature gradients near the surface of the levitated dipole is severely limited due to particle recycling (9, 10). Indeed, because the surface of dipole is completely surrounded by a dense plasma, the net particle flux to the ring must vanish. A cool, high-density sheath forms at the dipole surface which completely transforms the thermal flux to bremsstrahlung radiation. Kesner has predicted drift stability of dipole-confined plasmas with sufficiently gentle density gradients (11). Finally, a laboratory terrella built at Columbia University has studied the detailed phase-space evolution of dipole-trapped energetic plasma in the presence of intense drift-resonant fluctuations (12, 13). In this experiment, an "artificial radiation belt" (a population of 5–50 keV energetic electrons) is produced with microwave heating which allows investigation of instability thresholds when the hot electron pressure gradient sufficiently exceeds the "stationary", "marginally stable" profiles envisioned for the dipole reactor.

The potential for a levitated dipole to confine high-beta plasma with classical confinement and stability properties has motivated efforts to design an experiment which can explore the dipole fusion concept (14, 15). Using well-established superconducting and cryogenic technology, a concept exploration experiment has been designed with the primary objective of investigating the possibility of steady-state, high beta dipole confinement with near classical energy confinement. This proposed experiment is referred to as LDX, and it consists of a relatively small, 0.68 m diameter, superconducting ring levitated within a 4.5 m diameter vacuum vessel (Fig. 1). LDX has been configured to take advantage of existing equipment and facilities and serve as the lowest cost experiment to investigate the key physics issues of high-beta dipole confinement while simultaneously maintaining high confidence of its technical success. Careful consideration of several options for plasma formation, plasma heating and ring levitation or support led to the selection of a superconducting ring with the high beta plasma heated by ECRH. Our proposed experimental approach has two stages. First, multiple frequency

LDX - Base Case Parameters

Compression Ratio: 512
Adiabatic Pressure Ratio: 32,768
Minimum B at Ring: 0.24 T
Maximum B at Ring: 3.95 T

Linear Ring Stability:

Axial Growth Rate: 5 1/s
Horizontal Wobble: 0.5 Hz
Tilt Wobble: 1.6 Hz

Hot Electron Parameters:

Hot Electron Temp: 250 keV
Peak Density: 1-5 E11 /cm³
Outer Field Strength: 1.7 kG
Hot Electron Beta: >20%

Plasma Parameters:

Peak Density: > 1 E13 1/cm³
Plasma Beta: > 10%

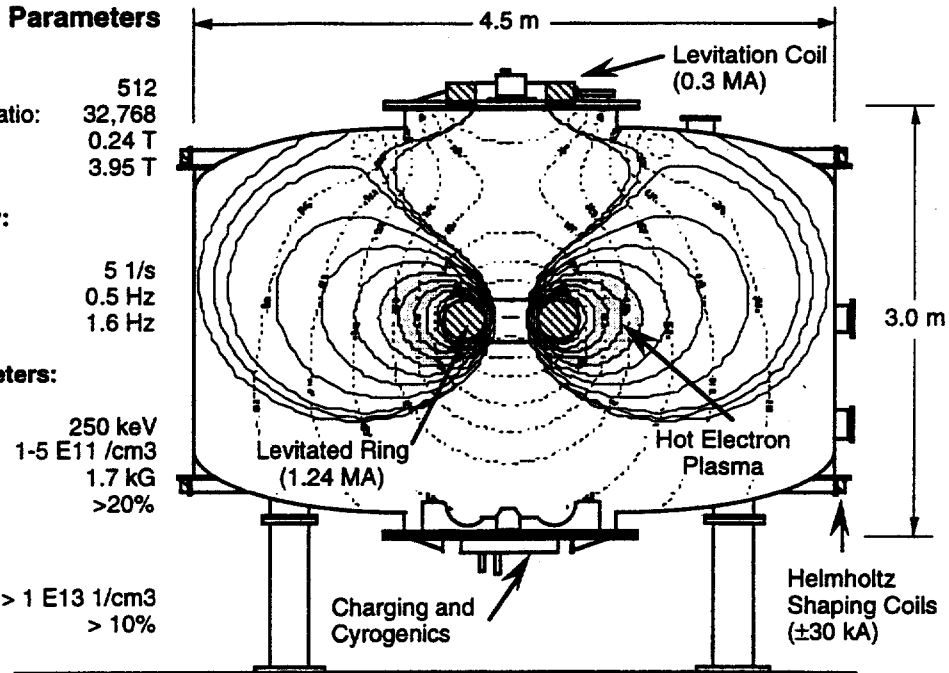

Figure 1. A cross-sectional view of the proposed LDX experiment.

ECRH (with frequencies between 6 and 28 GHz) is used to produce a population of energetic electrons at high $\beta \sim 1$. This technique has been proven effective in magnetic mirror experiments, but it requires a levitated dipole since the losses resulting from mechanical supports reduce hot electron confinement. Based on our experience generating hot electrons within mirrors and within CTX, we expect to create and sustain high beta plasmas using a few 10's of kW of ECRH power. Secondly, after formation of the high β hot electron plasma, fast deuterium gas puff techniques or the injection of lithium pellets will be utilized to thermalize the energy stored in the hot electrons and to raise the plasma density. The resulting thermal plasma will provide a test of MHD limits and confinement of a thermal plasma in a levitated dipole.

REFERENCES

1. A. Hasegawa, *Comments Plasma Phys. Controlled Fusion* 11 (1987) 147.
2. M. Schulz and L. Lanzerotti, *Particle Diffusion in the Radiation Belts* (Springer-Verlag, 1974).
3. S. M. Krimigis, *et al.*, *Science* 206 (1979) 977.
4. L. Chen and A. Hasegawa, *J. Geophys. Res.* 96 (1991) 1503.
5. R. Freeman, *et al.*, "Confinement of plasmas in the spherator," in *Proc. 4th Conf. Plasma Physics and Controlled Nuclear Fusion*, Madison, Wisconsin, June 17-23 (1971), IAEA-CN-28/A-3, Vol. 1, p. 27.
6. A. Hasegawa, L. Chen, M. E. Mauel, *Nuc. Fusion* 31 (1991).
7. A. Hasegawa, *et al.*, *Fusion Technology* 22 (1992) 27.
8. E. Teller, *et al.*, *Fusion Technology* 22 (1992) 82.
9. V. Pastukhov and A. Yu. Sokolov, *Nuc. Fusion* 32 (1992) 1725.
10. A. Yu. Sokolov, *Plasma Phys. Rep.* 19 (1993) 1454.
11. J. Kesner, *Phys. Plasma* 4 (1997) 419.
12. H. P. Warren and M. E. Mauel, *Phys. Rev. Lett.* 74 (1995) 1351.
13. H. P. Warren and M. E. Mauel, *Phys. Plasmas* 2 (1995) 4185.
14. J. Kesner and M. E. Mauel, to appear in *Plasma Physics Reports* 23 (1997) 742.
15. J. Kesner and M. E. Mauel, "Levitated Dipole Experiment," a proposal submitted to DOE ER Notice 97-08, May, 1997.

The Magnetic Dipole as an Attractive Fusion Reactor

John M. Dawson (UCLA)

Stability for low beta plasma confined by closed B field lines is $PV^\gamma = A_0$ (the A's represent constants), P = pressure, V = flux tube volume, gamma is the ratio of specific heats ($C_p/C_v = 5/3$). Kesner (J. Kesner, Innovative Confinement Concepts Workshop, Mar. 3-6, 1997) proposed a levitated current ring with the plasma stabilized satisfying this condition as an alternate fusion reactor. Such a reactor would have many attractive features. At radii large compared to the ring radius, V goes like r^4 ; the stability condition is $Pr^{20/3} = A_1$. If $nr^4 = A_2$, then an interchange keep the density constant. The remaining variation in P with r can be accomplished by a variation in the temperature; the temperature can drop according to $Tr^{8/3} = A_3$. If the chamber is ten times the ring radius, the density can drop from 10^{14} near the ring to 10^{10} at the edge and the temperature can drop from 50 KeV near the ring to 100 eV at the edge. This plasma should present no problems for a divertor.

Reacting plasma near the ring will raise its temperature, upsetting the stability relation. This causes convection to carry burnt plasma out to the edge; it will cool as it expands. At the same time the convection will bring in fresh fuel from the outside which will be compressed and heated to ignition. The process should be self-regulating in that if the burning accelerates the convection will become stronger. It will bring in more cooler fuel which will slow the burn. On the other hand, if the burning slows down, the convection will slow down and the burning will have more time to heat the fuel and restore the reaction rate.

If the physics of the stability is correct or essentially correct one might make an attractive reactor this way. The main area where there might be problems is in the area of kinetic driven instabilities. Some preliminary studies of such instabilities was carried out through numerical modeling by H. Goede (Goede H., D. G. Humanic and J. M. Dawson, Phys. Fluids, 26, 1812, 1983). They found that there were weak instabilities even when the

$PV^\gamma = A_0$ was satisfied. However, their system was a small one with the Larmor radius comparable to the radius. The instabilities found there might only contribute to the heat conduction but not to the formation of large scale convective cells. In such a case, it might not substantially alter the above conclusions. The problem clearly should be studied in more detail experimentally, computationally, and theoretically.

If the physics works then there is still a serious technological problem associated with having a levitated ring inside a fusion plasma. Some work has been done on this problem.

A super conducting ring design that can float in reacting D-He³ for 16 hours exists (J.M. Dawson, FUSION, edited by Edward Teller, Vol. 1, Magnetic Confinement, Part, Ch. 16, Academic Press, 1981). This is another area where additional work is called for.

GALATEYA TRAPS AS ALTERNATIVE BASIS FOR FUSION REACTORS

A.I.Morozov, V.I.Pistunovich

INF, RRC "Kurchatov Institute, Moscow, Russia

The problem of alternative approaches in the fusion is especially urgent at present. Such approaches, using stationary magnetic traps, are naturally to be sought from the following group of criteria[1,2]:

(a) Experimental traps with the hydrogen plasma of fusion parameters (TFP), i.e. with $n \sim 10^{14} \text{ cm}^{-3}$, $T_i \sim T_e \sim 10 \text{ keV}$, $\tau_E \sim 1 + 10 \text{ s}$ should be cheap and maximally use the acquired experience and equipment;

b) Transition from TFP to a fusion DEMO - reactor with the whole set of plasma - neutron processes but with the limited (say, $\sim 1000 \text{ s}$) operating cycle should be supported with the experimental models.

Along with the economical considerations, the following characteristics of an alternative system are of importance;

c) Integral $\beta=1$;

d) Classical transports;

e) "Crust" - like structure of a trap, when the main plasma volume is surrounded by a comparatively thin magnetic shell.

These characteristics are conformed each other. Since the plasma is diamagnetic, therefore the magnetic field should be used not as a habitat medium but as a "fence" (barrier). Then the conditions (c) and (e) - both, simultaneously - are satisfied. For providing classical transports at $\beta=1$ one should suppress the convection, using the magnetic field protuberance into plasma [3]. The cusp trap is such a system. However, it has large slits. They can be close by making transition to the toroidal systems. The simplest of them are the sets of two rings with currents passing with the same direction. The slits here are eliminated. However, a plasma spreading along the separatrix, needs the departure of the rings from a solid support, being suspended by a magnetic field. The magnetic levitation of a part of conductors, at least, in the trap with $\beta=1$, is unavoidable. The traps with the conductors around which the plasma passes were proposed to be called "Galateyas"[4,1]; the conductors submerged into the plasma, - "mixinas". Three specific problems are related with the mixinas in the fusion reactor:

a) suspension, b) energy release from mixinas into the reactor, c) current drive in the mixina.

Discussion about these problems is given in [1,4,5], as well as in a number of previous publications (see, e. g. [6,7]). The conceptional design, applicable to the DEMO reactor, is considered in [5, 8]. In the mentioned papers, it has been shown that the mixinas do not cause any serious engineering problems, but they radically improve the plasma characteristics of the traps. In particular, the transition to $\beta=1$ allows one to radically alleviate the magnetic system.

At the barrier magnetic field $B_b \approx 10^3 \text{ G}$ the plasma parameters may be next: $n \sim 10^{13} \text{ cm}^{-3}$, $T = T_i + T_e \approx 3 \text{ KeV}$. If one also takes account of the fact that one can use the hard suspension of a mixina at $\tau_E \leq 0.1 \text{ ms}$ and up to $\tau_E \sim 0.1 \text{ s}$ one can use the "jumping" non-superconducting mixina, it will be clear that the way to TFP turns out to be cheap.

A set of Galateyas is great and practically - unbounded [1,4]. Four types of Galateyas are of interest now. They are: Skornyakov - Peregoad "Tornado" [9], Okawa - Yoshikawa multipoles[7], Morozov - Frank belt-Galateya [10], Morozov's solid "ASTRON" (Galateya-A = Gal-A) [1], as well as electric discharge - modifications of multipoles and Gal-A's by Bugrova and Morozov [11,12].

All the above mentioned designs, in various modifications and scales are studying experimentally. In particular, in the multipole traps "ERL-M" with two rings under conditions of an electric discharge (Laboratory headed by A.I.Bugrova, Moscow Institute of Radio Electronics and Automation - MIREA), at the barrier field $B_b = 140 \text{ G}$ the plasma is confined at $n_e \sim 1.2 \times 10^{12} \text{ cm}^{-3}$, $T \approx 100 \text{ eV}$, $\tau_E \sim 50-70 \mu\text{s}$ [11]. In TORNADO at B_b of about 1 kG the plasma

parameters are greater by the order of magnitude [9]. In all the mentioned cases the transport has been explicitly close to the classical one. The TFP - parameters in an octupole trap under assumption of a classical transport have been estimated. In such a trap the plasma energy content should be of 3-5 MJ.

On the basis of an octupole one can estimate the scale of an experimental physical fusion reactor (EFR). Its main difference from TFR is the presence of a "thick" magnetic shell for mixina, neutron shield for mixinas and too the reactor, as a whole, as well as the presence of a "cooling bank" in the supercondition zone. The magnetic shell should be of about 3-4 Larmor radii of α -particles with the energy 3.5 Mev; the radiational shield will probably be about 0.6 m thickness. The cryozone diameter, superconductor and a cooling bank included, is of the order of 0.5m .

At the plasma density $n=1.5 \times 10^{14} \text{ cm}^{-3}$ with an adequate barrier field $B_0 \approx 1.2 \text{ T}$ and at the neutron flux density per mixina 1 MW/m^2 the magnetic mixina shell will be about 0.5 m thickness. Then the main plasma diameter will be about 2 m. Taking account of the data about the mixina size, one obtains an estimate for the plasma volume about 200 m^3 .

A solid ASTRON (Galateya-A \equiv Gal-A) can be of interest for the fusion. However, there is a number of problems for a special analysis.

References

- [1] Morozov A.I. On "GALATEYAS" - traps with the conductors flown about by plasma . Fizika Plazmy, 1992, v.18, p.3.
- [2] Morozov A.I. Ideal traps and the problem of their realization. Abstracts of Reports to the XXIV Zvenigorod Confer. on Plasma Physics and Controlled Fusion, 1997, p.59.
- [3] Braginski S.I., Kadomtsev B.B., Plasma Stability with the Guard Conductor; collection Plasma Physics and Fusion Reactor Problem by M.A.Leontovich, Academy of Sciences, USSR, 1958, v.III, p.300-336.
- [4] Morozov A.I. On magnetic traps with the conductors submerges into plasma. Pis`ma JTP, 1990, v.16, issue 15, p.86.
- [5] Morozov A.I., Khripunov V.I. Estimate of circular mixina parameters for fusion Galatea - reactors. Fizika Plazmy, 1992, v.18, N7, p.838.
- [6] Sakharov A.D. Theory of a magnetic fusion reactor. Plasma Physics and Fusion Reactor Problem by M.A.Leontovich, Academy of Sciences, USSR, 1958, v.I, p.20.
- [7] Yoshikawa S. Experiments on plasma confinement in internal-ring devices. Nucl. Fusion 1973, v.13, p.433.
- [8] Morozov A.I., Nevrovsky V.A., Pistunovich V.I., Report at the EPFR Conf., St. Petersburg, 1997.
- [9] Peregoad B.P., Lehnert, Nucl. Just. Meth. , 1981, v.180, p.357.
- [10] Morozov A.I., Frank A.G. Fizika Plazmy, 1994, v.26, issue 11,
- [11] Bugrova A.I., Lipatov A.S., Morozov A.I., Krarchevnikov V.A., Electric discharge trap on the basis of the closed quadrupole, Fizika Plazmy, 1993, v.19, N8, p.972; N12, p.14.
- [12] Bugrova A.I., Lipatov A.S., Morozov A.I., Krarchevnikov V.A., Open type Galateya. Pis`ma JTP, 1994, v.20, issue 19, p.51.

The Los Alamos Intense Neutron Source and the Penning Fusion Experiment

R. A. Nebel, D. C. Barnes, R. Bollman,
G. Eden, L. Morrison, M. M. Pickrell, W. Reass,
M. M. Schauer, K. R. Umstadter
Los Alamos National Laboratory
Los Alamos, New Mexico 87545

Introduction

The Intense Neutron Source (INS) is an Inertial Electrostatic Confinement (IEC) fusion device presently under construction at Los Alamos National Laboratory. It is designed to produce 10¹¹ neutrons per second steady-state using and will be used for nuclear assay applications. It is being built in a hot cell and will operate with a deuterium-tritium fuel mixture. This device is a three grid IEC ion focus device. Expected performance has been predicted by scaling from a previous IEC device.¹ In this paper we describe the physics principles of operation of this device, the engineering design parameters, and the empirical scaling used to determine the design parameters.

A new method of operating an Inertial Electrostatic Confinement (IEC) device is also proposed and its performance is evaluated. The scheme involves an oscillating thermal cloud of ions immersed in bath of electrons which form a harmonic oscillator potential. The scheme is called the Periodically Oscillating Plasma Sphere and it appears to solve many of the problems which may limit other IEC systems to low gain. A set of self-similar solutions to the ion fluid equations are presented and plasma performance is evaluated. Results indicate that Q enhancement of gridded IEC systems such as the Los Alamos INS device is possible as well as operation with $Q > 1$ for low loss systems such as the PFX-I Penning Trap Experiment. A conceptual idea for a massively modular Penning Trap reactor is also presented.

1. R. L. Hirsch, J. Appl. Physics 38, 4522 (1967).

**SPHERICAL TORI AND
SPHEROMAKS**

The Spherical Tokamak Route to Fusion Power Applications

T N Todd, A Bond*, M O'Brien, I Cook, M Cox, M Gryaznevich, T C Hender, P J Knight, A W Morris, K McClements, M P S Nightingale, D C Robinson, A Sykes, M J Walsh, H R Wilson

UKAEA/Euratom Fusion Association, Culham Science Centre,
Abingdon, Oxon, OX14 3DB, UK, *Reaction Engines Limited, Oxford, UK

Introduction

The success of the pioneering Spherical Tokamak experiment START [1], has resulted in a number of proposals for experimental devices of this type, several of which are now under construction (most notably MAST, NSTX, Globus-M, ETE and Pegasus [2-6]). The very low plasma aspect ratio and associated high natural elongation of the ST allow large values of I_p/aB_T to be stably achieved, permitting designs with both high β , ie the ratio of plasma pressure to magnetic field pressure, and a large plasma current for a modest toroidal field strength. Progress in experimental results has been very encouraging, as exemplified by the recent results from START with high power neutral beam heating described below [1]. The attributes of ST's facilitate the design of high performance DT fusion machines with small unit size (comparable to that of some tokamaks now in operation) and correspondingly low capital costs, providing an economically efficient route through component test facilities and pilot plants, to fusion power generation [7,8]. The high- β capability of the ST, which corresponds to a high power density, makes the concept attractive as the basis for a 14MeV volume neutron source for component testing [9]. Power plant studies are on-going to optimise the factors affecting the economic advantages of the concept, including the recycled power fraction, projected down-time for maintenance and materials selection issues.

High I_p/aB_T

Power plant studies for magnetic confinement fusion systems have invariably highlighted the need for the largest possible β , in order to maximise the power production for a given engineered assembly. In tokamak systems, the need to sustain the plasma current at minimum cost leads to a preference for a large bootstrap current fraction, again pointing to a requirement for high β . In tokamaks, including ST's, the first stability β limit is theoretically predicted to scale predominantly as I_p/aB_T [10]. The requirement for large power density and a high bootstrap fraction implies that high values of both β and $\beta_N (= \beta a B_T / I_p)$ are needed for competitive electricity generation (eg volume average β 50%), which could be addressed by increasing the plasma elongation or moving into the second stability region. Raising the elongation (at a given edge safety factor, q) permits higher I_p/aB_T , which is $\propto (R/a) I_p / I_{TF}$, with I_p / I_{TF} playing a clear role in plasma performance versus the resistive power required to support the toroidal field. Theoretical predictions for the β in ST's in the first stability limit for ballooning and low n-modes [1] show an optimum at κ 2.7, somewhat above the natural elongation for the pressure and current profiles assumed. The START shots with highest β feature I_p / I_{TF} 1.2, at an elongation of 1.8 and $q_{95} \approx 2.3$ (close to the ideal $n=1$ q -limit), showing that low q is achievable in an ST.

START experimental results

Recent experimental results from START using a neutral beam injector on loan from ORNL confirm the very high I_p/aB_T and β capability of the ST configuration, as shown in figure 1. The 33% volume averaged β achieved so far (close to the conventional beta limit for this configuration, which has β_N 4.4) includes up to 20% attributed to fast ions from the neutral beam heating. This shot featured plasma current ramping up, and toroidal field ramping down, while the power of the neutral beam injection (28keV 500kW) remained essentially constant. The best plasma parameters were $R=0.31m$, $a=0.23m$, $\kappa=1.8$, $I_p=250kA$, $I_{TF}=210kA$, $q_{95}=2.3$, $n_e=6 \times 10^{19} m^{-3}$, $T_{e0} \approx T_{i0} \approx 220eV$, working species = deuterium, NBI species = hydrogen. The vacuum vessel had been boronised and was glow cleaned in helium and titanium

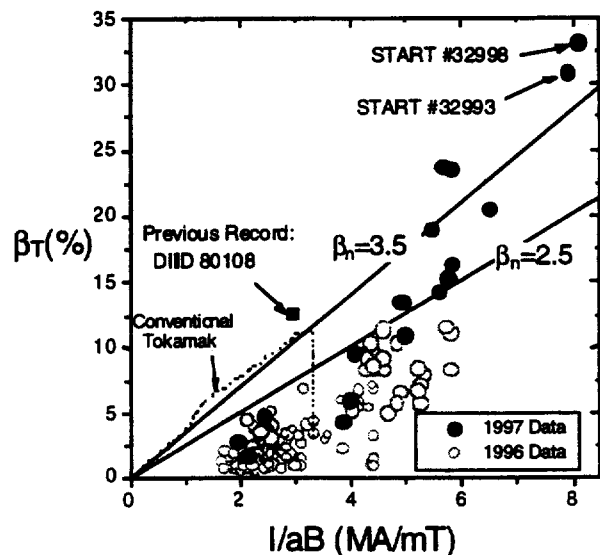

Fig.1: High β discharges attained in START

gettered between shots. START data (supported by results from CDX-U) confirms expectations that vertical position is much less unstable than in conventional systems, greatly reducing halo currents (and asymmetries) [11,12].

Long-pulse issues

The theoretically predicted bootstrap current appears to be sufficient for steady state operation, perhaps with a small seed current driven in the core region by neutral beams or High Harmonic Fast Waves. However any long-pulse implementation will bring the attention of the designers to the ubiquitous fusion problem of divertor geometry and materials selection. The power handling capability of the first wall and divertor is a vital consideration in the overall economic analysis (as for any other magnetic confinement system). Although possibly tractable with existing materials (e.g. by flux expansion in the divertor zone), this will benefit from further developments, eg composite structures resistant to radiation damage. These would allow higher wall loading in an ST power plant (eg $\gg 5\text{MWm}^{-2}$), which could be achieved more readily than in a conventional tokamak due to the much higher β capability, permitting further gains in economic performance.

Centre Column

The key to any successful ST reactor will be the centre column assembly and the achievable lifetime for this component against neutron radiation effects (with the concomitant gamma radiation adding significantly to the core cooling requirement). Two aspects of radiation damage dominate the thinking: the maximum activity allowed if repository disposal of the waste material is to be avoided, and the effect on conductor resistivity (and hence recycled power) due to the transmutation products. Alumina-dispersion-hardened copper has much better resistance to swelling than pure copper and the resistivity would remain acceptable for several years in a power plant application [13]. The core activation problem might be improved by introducing a slim neutron shield (with care to maintain the full economics optimisation) which would also facilitate moving to the alternative of an aluminium central conductor. For either material, a minimisation exists in the sum of Joule heating power in the conductor and refrigeration demand, typically leading to a preferred temperature spanning 14-40K for the aluminium (and near-ambient for the copper). Possible radical solutions for the core include the option of dispensing with the material structure in the centre altogether, as exemplified in the proposed SPHERA device [14]. This would feature toroidal field production by an axial screw-pinch current channel, kink stabilised by the poloidal field of the surrounding toroidal plasma current.

Alpha Particles

Preliminary analyses have been made of alpha-particle behaviour in a reactor-scale ST with $I_p=30\text{MA}$, $R=0.5 \rightarrow 3.5\text{m}$. It is found that the large poloidal fields in such devices keep orbit losses, at least in the axisymmetric configurations considered so far, at negligible levels. In smaller volume neutron source devices (such as the Component Test Facility discussed below), it is found that alpha-particle confinement is very sensitive to I_p . A high degree of alpha-particle confinement indicates that the alpha-particle velocity distribution could be close to isotropy. One consequence of the relatively low magnetic fields in STs is that alpha-particles in the plasma core are generally super-Alfvénic. This implies that there could be a strong instability drive for Alfvén eigenmodes, and possibly also for higher frequency modes such as the magnetoacoustic cyclotron instability, but the detailed behaviour and non-linear consequences of these have yet to be modelled in ST geometry.

Component Test Facility Studies

The various optimisations mentioned above have been pursued in a detailed study of a driven volume neutron source, ie a test facility for components of 1 metre scale [9]. As well as being a favourable design basis for a "CTF" (which is in any case required for materials development), this is also seen as a credible step on the route towards an ignited, self-sustaining ST power plant. The leading parameters of this CTF design, sketched in

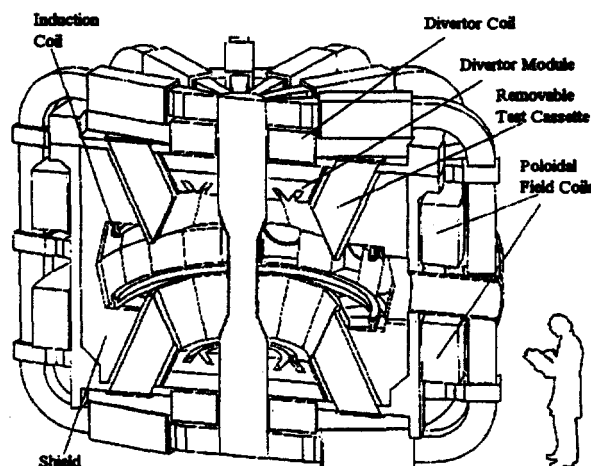

Fig.2: Cutaway view of CTF device

fig 2, are $R = 0.07 \rightarrow 1\text{m}$, $R/a=1.6$, $\kappa = 2.3$, DND configuration, $I_p = 7 \rightarrow 10\text{MA}$, $P_{\text{NBI}} = 25\text{MW}$, $Q=1$, neutron wall loading = 1.6MWm^{-2} . Significant analysis effort has been put into estimating overall maintenance requirements for this CTF, concluding that availability would average 44%, a factor included in the various design optimisation procedures. The CTF design features a single-turn central conductor (as used routinely in START) so that insulators are unnecessary, although attention then has to be paid to minimising resistance of all the electrical joints in the TF circuit. These would probably include some form of sliding joints, as used in the START, Alcator C-MOD and MAST TF centre stacks[15].

Conclusions:

The experimental results from START are strongly encouraging but still require some extrapolation to match typical ST power plant assumptions. However, they are already in the relevant (high β) parameter space for an economically attractive neutron source for materials development and component tests, needed to support fusion research in general. Future experiments on START will seek to raise the achievable β and β_N still further, including tests of plasma profile and confinement modifications by deuterium pellet injection, in combination with higher power neutral beam heating. The ST presently appears to be a very promising alternate line, offering a combination of stability, confinement and operating space at least equalling that of conventional tokamak scalings, at the same time as very much greater central and volume averaged β . The principle areas of technology development required are to a large extent shared by the conventional tokamak approach, but the key ST advantage of high fusion performance in a compact device would seem to be increasingly borne out by experimental results and the various design studies for future machines.

References

- [1] Sykes, A, et al, EPS 1997 Topical Lecture 10
- [2] Darke, A C, et al, SOFE 1995 Vol.II p1456
- [3] Chrzanowski, J H, et al, SOFE 1995 Vol.II p1430
- [4] Golant, V E, et al, SOFE 1995 Vol.II p1464
- [5] Del Bosco, E, et al, Proc of the 1996 Internat Workshop on the ST, Culham, Vol.I, p583
- [6] Fonck, R, Proc of the 1996 Internat Workshop on the ST, Culham, Vol.I, p49
- [7] Stambaugh, R D, et al, Fusion Technology Vol.30 part 2a, p1380; Proc of the 12th Topical Meeting of Fusion Energy, Reno, 1996
- [8] Peng, Y K M, IAEA 1995 Vol.II p643
- [9] Hender, T C, et al, EPS 1995 Vol. III, p 233.
- [10] O'Brien, M, et al, IAEA 1996, paper IAEA -CN-64/C2-1
- [11] Castle, G G, et al, EPS 1997, paper P1/065
- [12] Ono, M, et al, IAEA 1996, paper IAEA -CN-64/C2-2
- [13] Butterworth, G, et al, Jnl Nucl Materials 189 (1992) 237
- [14] Alladio, F, and Micozzi, P, Proc of the 1996 Internat Workshop on the ST, Culham, Vol.I, p390
- [15] Voss, G M, Proc of the 1996 Internat Workshop on the ST, Culham, Vol.II, p792

*This work was jointly funded by the UK Department of Trade and Industry and Euratom.
The neutral beam injector was supplied by US DoE and ORNL.*

Scientific Innovation of Interest to NSTX Research*

Y.-K. Martin Peng and Contributing Scientists

*Princeton Plasma Physics Laboratory, Oak Ridge National Laboratory,
University of Washington, Columbia University,
Massachusetts Institute of Technology, Johns Hopkins University,
University of California San Diego, University of Texas Austin, etc.*

Recent data from pioneering tests of spherical torus (ST) plasmas (CDX-U, START, HIT, TS-3, etc.) have continued to be very encouraging. Projections of highly compact ST fusion cores ($R_0 \geq 1$ m) for proof-of-performance test and nearer-term applications such as the Volume Neutron Source (VNS) have helped clarify the physics issues of importance to NSTX research. Analyses of such issues point to investigations of interest to NSTX, MAST, and GLOBUS-M, and indicate opportunities for discovery, innovation and advancement in plasma and fusion science.

These results show that, in contrast with the tokamak plasma, the ST plasma

1. Minimizes magnetic flux and helicity per plasma current, leading to efficient noninductive startup and current drive via helicity injection and bootstrap current overdrive;
2. Has stable ultrahigh betas, high elongations, and strong magnetic wells with fully aligned self-driven (bootstrap) currents;
3. Possesses large normalized gyroradius, strong sheared and diamagnetic flows, and strong magnetic shear;
4. Increases dielectric constant and absorption of High Harmonic Fast Waves, and possibilities of ECH access via conversion to Electron Bernstein Wave;
5. Has modest plasma Alfvén speeds readily surpassed by suprathermal ions or thermal ions at high temperatures; and
6. Shows scrape-off-layer with large mirror ratios, large flux tube expansion, strong field line curvature, and naturally diverted flux tubes;
7. Encourages innovation in diagnostics, particularly for current profiles and core fluctuations.

Successful outcome from the ST physics innovation is expected to help broaden the support for magnetic fusion; expand it into nearer-term and more diverse markets; and introduce potentially exciting short-term deliverables for R&D.

* Work supported by the U.S. Dept. of Energy under Contract Nos. DE-ACO5-96OR22464 and DE-ACO2-76CH03073, etc.

Addressing Spheromak Physics in the Sustained Spheromak Physics Experiment, SSPX

E. B. Hooper
Lawrence Livermore National Laboratory

SSPX is being constructed to study the physics of the dynamo and energy confinement in a low-to-moderate collisionality spheromak sustained by helicity injection from a coaxial source. The geometry is designed to be stable to the tilt and shift modes (on the flux conserver time-scale, and to minimize field errors while permitting access for diagnostics. To optimize the performance, careful attention is placed on vacuum issues: low base pressure, bake-out, protection of copper surfaces by tungsten coatings, and boronization will all be used. A magnetic divertor is planned for active pumping during the discharge. To provide configurational flexibility a bias flux is planned, with the vacuum field lines designed to be tangent to the flux conserver, thus minimizing field errors. The most important physics issue to be addressed are the effects of magnetic islands and/or turbulence in determining the spheromak characteristics. Fluctuations are expected to distribute the helicity throughout the plasma volume; opening of the magnetic surfaces then allows energy losses. Diagnostics to address this problem include magnetic (edge) probes and ultra-short pulse reflectometry; cross coupling between polarizations is a measure of the magnetic field shear in the plasma. Additional diagnostics to address critical physics will be discussed.

*Work performed under the auspices of the U.S. Department of Energy by Lawrence Livermore National Laboratory under Contract No. W-7405-ENG-48.

MRX-CT Experiment, Study of Compact Toroids Formed by Induction and Merging

M. Yamada, H. Ji, and P. Heitzenroeder, PPPL, Princeton Univ., Princeton New Jersey 08543, USA

Compact toroidal plasma configurations, such as FRCs (field reversed configurations), ion rings, spheromaks, spherical toruses, and RFPs (reversed-field pinches) have been extensively studied in search of a cost-effective, high-performance, high-power-density reactor core[1]. Since such configurations have characteristically high-beta plasmas, they hold promise for opening the road to an advanced-fuel reactor, provided confinement is sufficiently favorable. They can also lead to compact volumetric D-T neutron sources. Compact toroids, such as FRCs and spheromaks, which do not require external toroidal coils, have significant reactor advantages[1-3]. This is because their singly connected toroidal geometry allows reactor designs in which the scrape-off layer carries the power and particle exhaust outside the coil system, thereby easing the engineering constraints for particle pumping, impurity control, and power exhaust. They can, however, suffer from serious global MHD instabilities. Spherical toruses with central stacks, which possess good tokamak stability features, have also been studied. This has led to access of the compact, high-performance low aspect ratio tokamak regime.

It is also very useful to explore the commonality and the relationships among various low aspect ratio compact plasma configurations with internal current, since this should reveal the best advantages of each concept for compact reactor design. Low aspect ratio RFPs have several attractive features with the number of unstable modes expected to decrease and the distance between rational surfaces to increase[4]. The spherical tokamak (ST) configuration in low-beta regimes is similar to the spheromak in its strong paramagnetism and magnetic helical pitch[5]. As the plasma pressure of STs approach the high-beta limit (~ 0.5), the paramagnetism recedes and the MHD equilibrium features, deviating from those of standard tokamaks, become similar to those of FRCs.

Among these compact toroidal configurations, the FRC is uniquely attractive for a compact fusion reactor core. It has the highest beta (near unity) conceptually attainable in equilibrium. This high-beta equilibrium has been successfully attained in relatively small devices, although its lifetime is limited to the order of the energy confinement time (< 1 msec). Properly formed FRC plasmas appear experimentally to be quite stable to global modes. If questions regarding formation, stability, sustainment, and confinement are successfully resolved, then FRCs may offer a high-power-density and easily maintainable alternative approach to fusion power production. The major weakness in FRC research is that there are significant uncertainties in the confinement and stability properties[3]. The basic understanding of these characteristics is of the highest priority in the alternative concept fusion research community. In addition, it is highly desirable to develop a scheme for sustaining the FRC in quasi steady-state.

We have proposed a concept exploration device called MRX-CT to investigate comprehensively the MHD stability and the confinement features of FRCs in comparison with other CT plasmas, by maintaining such plasmas for much longer than their energy confinement times. Primary objectives of the proposed research are: (1) Form FRCs by merging two spheromaks with opposite helicities, made by the flux core induction scheme, and (2) assess the global stability characteristics and confinement of FRCs by varying the important stability parameter s in order to understand kinetic effects and by using passive stabilizers. (3) Sustain the FRC for a significantly longer time (1-10 msec) than the energy confinement time using a center stack ohmic-heating (OH) transformer and/or NBI current drive to provide a firm base for assessing confinement characteristics of FRC plasmas. (4) Another important task of this program will be the comparative investigation of the global characteristics of all compact, current-carrying toroidal configurations.

In the proposed MRX-CT device, FRC plasmas and other compact toroidal plasmas can be generated by utilizing inductive formation schemes followed by merging of co- and counter helicity spheromaks. Figure 1 depicts a schematic of the MRX-CT device. This novel inductive formation scheme, which invokes neither conventional fast shock heating nor electrode discharges, has significant advantages for the development of a compact reactor core. Two spheromak plasmas, which have toroidal fields and currents, can merge to form a larger (or higher field) plasma, making it possible to separate the plasma formation section from the reaction chamber .

A series of successful spheromak merging experiments have been carried out in the TS-3 (at the University of Tokyo) and MRX (at PPPL) devices in which FRC configurations were formed by merging two toroidal plasmas with opposing toroidal fields[6-8]. The opposing toroidal flux of the two merging spheromaks is annihilated during the merging thus allowing the formation of an FRC with $\beta \sim 1$. Ion acceleration and direct ion heating were observed during this counter-helicity merging. The large increase of ion temperature from 10 to 200 eV was attributed to the direct conversion of annihilated toroidal field energy to ion kinetic energy during the process of magnetic reconnection. This observation was also verified by MHD and macro-particle simulations [9].

The proposed MRX-CT will be dedicated to the exploration of new regimes of compact toroid configurations, in particular, FRCs with variable ratio of the ion gyro-radius to the plasma size and low aspect ratio RFPs. Based on the results from MRX and TS-3, it is expected that counter-helicity merging of two spheromaks will lead to the formation of FRC plasmas with a toroidal current of up to 200 kA and with a separatrix radius R_s of up to 50 cm. The gyro-radii of ions can be significantly smaller than R_s , and their ratio s will be varied over a wide range (2-40). Here $s \sim 4 \bar{s}$;[2]. Important questions are for what s values are these CT plasmas susceptible to a tilt mode, and under what conditions can they be made stable with conductive shells. A center stack which contains an OH transformer will be inserted to extend the lifetime of FRC plasmas to more than one millisecond and/or further increase the plasma current, so that a confinement study can be carried out in a quasi steady-state regime. The MHD characteristics and global confinement features of the four different compact toroid plasmas with additional ohmic current drive by the center stack will be comparatively investigated in the Phase I research stage[10].

Additionally, MRX-CT can create a low aspect ratio RFP ($R/a = 1.05-1.5$), which has never been studied before. By programming the TF and PF coil currents of the two flux cores and a small TF current of the center stack, RFP configurations can be generated in MRX-CT. In this setup, the unique characteristics of the low aspect ratio RFP, in which only a few resonant surfaces (of $n=2, 3, \dots$) exist in the core plasma, will be studied.

In the upgraded MRX-CT experiment, NBI of 2-5 megawatts will be employed to extend the lifetime of the plasma beyond ten milliseconds, significantly broadening the scope of the experiment by actively controlling the plasma stability with toroidal rotation and additional beam heating.

This program complements the LSX-Mod program at the University of Washington in very important areas[11]: (1) To sustain FRC configurations, RF current drive (Rotamak scheme) will be employed in LSX, while OH transformer and NBI upgrade will be utilized in MRX-CT. (2) To generate initial plasmas, the fast theta pinch plus translation scheme will be employed in LSX-Mod, while slow induction and merging will be utilized in MRX-CT to create plasmas with a wide range of s (2-40).

References

- [1] "Compact Toroids," Special Issue, Fusion Tech. 9 (1986).
- [2] M. Tuszewski, "Field Reversed Configurations," Nucl. Fusion 28 (1988) 2033.
D.C. Barnes et al. Phys. Fluids 29, 2616 (1986)

- [3] L.C. Steinhauer, *et al.*, "FRC 2001: A White Paper on FRC Development in the Next Five Years," *Fusion Tech.* 30 (1996) 116.
- [4] Y.L. Ho, *et al.*, "Effect of Aspect Ratio on Magnetic Field Fluctuations in the Reversed Field Pinch," *Phys. Plasmas* 2 (1995) 3407.
- [5] M. Yamada, *et al.*, "Global Stability Study of the Ultra Low Aspect Ratio Tokamak, ULART," *Nucl. Fusion* 36 (1996) 1210.
- [6] M. Katsurai and M. Yamada, "Studies of Conceptual Spheromak Fusion Reactors," *Nucl. Fusion* 22 (1982) 1407.
- [7] M. Yamada, *et al.*, "Magnetic Reconnection of Plasma Toroids with Co-helicity and Counter-helicity," *Phys. Rev. Lett.* 65 (1990) 721.
- [8] Y. Ono, *et al.*, "Merging of Two Spheromaks and Its Application to Slow Formation of a Field Reversed Configuration," in *Plasma Physics and Controlled Nuclear Fusion Research 1992* (Proc. 14th Int. Conf., Würzburg, Germany, 1992), Vol. 2 (International Atomic Energy Agency, Vienna, 1993) 619;
- [9] Y. Ono, *et al.*, "Ion Acceleration and Direct Ion Heating in Three-component Magnetic Reconnection," *Phys. Rev. Lett.* 76 (1996) 3328.
- [10] M. Yamada, *et al.*, "Comparative Study of Compact Toroid Plasmas Formed by Induction and Reconnection," in *Fusion Energy 1996* (Proc. 16th Int. Conf., Montreal, Canada, 1996), Paper IAEA-CN-64/CP-19, to be published by the International Atomic Energy Agency, Vienna, 1997.
- [11] A.L. Hoffman, "Steady State FRC Development Program," presented at the Conference of Advanced Approaches to Economic Fusion Power, Monterey, California, September 12-14, 1995.

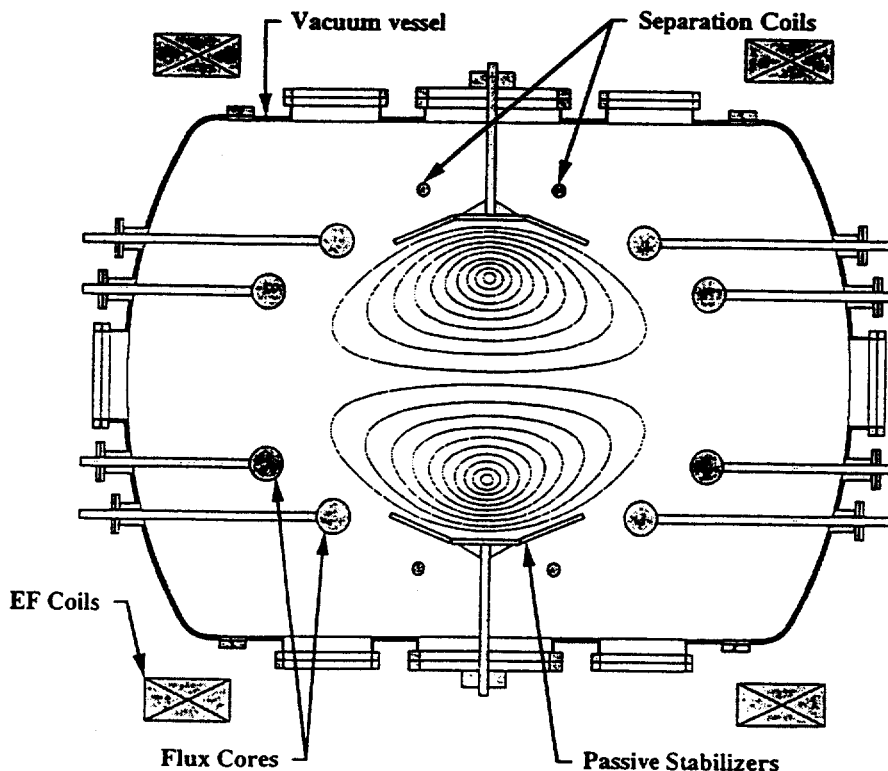

Figure 1. Schematic view of the proposed MRX-CT device.

RFPs AND STELLARATORS

THE REVERSED FIELD PINCH: ADVANCES AND PROSPECTS

S.C. Prager
University of Wisconsin-Madison

The reversed field pinch (RFP) fusion concept is an old idea, having been first studied several decades ago. With the spheromak, it belongs to the family of axisymmetric toroidal systems with safety factor $q < 1$. Such configurations require only a relatively weak toroidal magnetic field (about ten times weaker than a tokamak of similar toroidal plasma current). It has long been recognized that this feature spawns a set of potentially attractive reactor features: high beta, weak field at the magnet coils, normal (not superconducting) coils, and relatively small size and high power density. In addition all present experiments appear to operate essentially free of disruptions, and our present physics understanding suggests that the aspect ratio may be a weak determinant of RFP behavior and may be set by engineering considerations.

However, the low magnetic field (and low safety factor) also introduce several physics penalties which must be surmounted. The absence of the strong field permits the appearance of several Fourier components of resistive tearing modes, with magnetic field fluctuations about equal to 1% of the equilibrium field. These fluctuations presumably cause the field to become stochastic, yielding substantial radial transport of particles and energy. Over the past decade or more, the understanding of these fluctuations, through careful measurement and nonlinear MHD theory/computation, has expanded greatly. In recent years, techniques to control the fluctuations have been developed, and initial control experiments have produced significant confinement improvement. Thus, a solution to the problem of large magnetic fluctuations in the RFP can be at least conceived, with promising first steps. The RFP concept can now be reappraised, and in part redefined. The near-term future RFP program should move toward a focus on control, and toward inclusion of problems beyond confinement. The RFP programs in Japan, Italy, Sweden, and the U.S. offer the potential for continued dramatic improvement in RFP performance and understanding. The four areas in which control systems can have great impact are confinement, beta limits, resistive wall instabilities, and current sustainment.

Confinement over the bulk of the plasma is believed to be dominated by particle motion parallel to the magnetic field. Magnetic fluctuations are fairly well predicted by nonlinear resistive MHD. It has been established in experiments that these magnetic fluctuations drive transport at least in the immediate vicinity of the reversal surface. MHD provides guidance on the suppression of the fluctuations by current profile control. Initial attempts at inductive current profile control have halved the magnetic fluctuations, increased beta by about 50%, reduced the Ohmic input power several-fold, and increased the energy confinement time about five-fold (in MST). An important next step is to optimize this effect through improved current profile control, such as with lower hybrid waves. A key theoretical next step is to fully optimize the RFP (minimize magnetic fluctuations) by determining, via nonlinear resistive MHD studies, the optimal combination of profiles (current, pressure, flow) and geometric properties (aspect ratio, cross-sectional shape).

This optimization will also determine the maximum beta permitted in the RFP configuration. All experiments have operated routinely at rather high values of beta, about 10%, with values as high as 20% obtained under some conditions. However, it is not known whether the experimental beta values are determined by a stability limit or by transport. The most direct way to answer this question is through auxiliary heating to vary the experimental beta value. To date, no RFP has been operated with either auxiliary heating or non-Ohmic current drive.

Control systems are also needed to stabilize MHD modes (ideal kinks and resistive tearing modes) which grow unstably in the absence of a close-fitting conducting shell. These modes have been observed in experiments with a resistive shell, and the external kink has been successfully feedback stabilized (in HBTX). It is critical to continue these

studies on other devices to determine whether the feedback of multiple modes can be accomplished, and whether other effects (such as plasma rotation) can be stabilizing.

An area of relative neglect has been the development of techniques to sustain the RFP current. One technique proposed years ago aims to inject magnetic helicity by simultaneously oscillating the toroidal and poloidal loop voltages. This technique, called Oscillating Field Current Drive (OFCD) or ac helicity injection, has produced a trace amount of current (about 5%) in ZT40-M. A complete test requires a device with a lower plasma resistance than ZT40-M, such as exists in some extant experiments. A key question for this technique is whether the fluctuations needed to relax the injected current also degrade confinement.

In summary, RFP research is at a possible transition point, with a variety of key issues able to be advanced through the application of control systems. Such approaches may partly redefine the RFP concept. The issues described above also apply to the neighboring configuration of the spheromak.

Divertor RFP Plasma and Some Considerations at Ignited Plasma Conditions

K. Hayase, Y. Sato, S. Kiyama, M. Watanabe*

Electrotechnical Laboratory

1-1-4, Umezono, Tsukuba, Ibaraki 305, JAPAN

*Dept. Electricity and Electronics Engineering, Iwate University
4-3-5, Ueda, Morioka, Iwate 020, JAPAN

The reversed field pinch is one of the candidates for simple and economical fusion reactors in the characteristics of normal conductor toroidal coils, Ohmic ignition (no additional heating), a compact core plasma, easy exchange of first-wall materials owing to the easy disassembly of normal conductor toroidal coils, and so on. At Electrotechnical Laboratory in Japan, RFP has long been pursued as one of alternatives in the national fusion research and development program. The efforts are devoted for developing plasma parameters such as temperature and energy confinement and PSI control technology such as the divertor. We present here mainly the progress of divertor experiment on TPE-2M in Part 1, and future perspectives of RFP plasma ignition in Part 2.

TPE-2M is a small reversed field pinch machine (major and minor radii are 0.73 m and 0.19 m, respectively, the maximum plasma current is 200 kA, and the maximum discharge duration is around 15ms). The divertor RFP concept was first proposed by LANL group[1]. The experiment was carried out by the octapole RFP[2], and then by STE-2[3] and TPE-2M[4-6]. The first study in TPE-2M is the observation of MHD behaviors and particle transport of axisymmetric poloidal divertor RFP plasma. The results are reported in previous IAEA Fusion Energy Conferences[7,8]. The conducting shell is inevitably essential to the stability in RFP, compared to tokamak and stellarator, so that the divertor configuration is set up by an axisymmetric cut of close-fitting conducting shell and divertor hoop coil just outside of the shell cut. The combination of shell cut and outside divertor hoop coil enables both the X-point and limiter configurations, by controlling the ratio of plasma and divertor coil currents. The discharge duration at the plasma current of 50 kA is

around 5 ms so far due to the limitation of power circuit and a strong recycling process.

The dynamo process, which is essential to the flux generation in the RFP, is compared with the normal RFP discharge and was shown to be unchanged[9]. The edge plasma properties are intensively studied to clarify any changes of stability in the edge plasma region due to the modification of magnetic profile by the divertor field[10]. The high frequency fluctuation levels of magnetic field on the wall surface and the ion saturation current in a Langmuir probe at the plasma edge do not significantly change with the divertor field, but the low frequency level of fluctuations is much correlated with the dynamo process, that is, the pulsed increase of fluctuation occurs in Langmuir probe and impurity lines signals. The soft X-ray intensity enhances slightly with the divertor field, but it decays rapidly. The average particle outward-flow does not decrease at the opposite side of X-point. The average light impurity intensity does not decrease, while, the heavy impurity intensity tends to decrease slightly with the divertor field. The heat deposition of particle flux to the wall near the X-point is quite large (but less than the evaporating temperature, thus the evaporation of the wall surface is suppressed). These results indicate that the divertor field acts the role of diverting the plasma, however, the significant reduction of diffusion toward non-diverting region is not yet clear. One of possible reasons is the deterioration of stability and enhancement of fluctuation due to the reduction of shell proximity caused by the divertor field.

The modified vessel with an inner stabilizing shell and additional divertor space is installed in the second phase of TPE-2M experiment (the minor radius is increased to 0.28 m at the same time). In this structure the diverted plasma is effused from the shell cut to the divertor space. The axisymmetric shell cut in the former version is 15 degrees. The equilibrium calculation shows a less proximity at a larger shell cut angle. The discharge duration is around 5 ms at 70 kA. The interaction of plasma with the shell surface is evidently reduced; C, O and Al (shell material) line decreased. However, the axis oscillation of plasma column along the shell cut direction ($m/n=1/0$ mode) are seen in some discharges. The discharge characteristics are similar with the very low q

tokamak discharge ($0 < q < 1$). The difference is that the discharge continues longer (8 ms) in the low q tokamak operation. The toroidal loop voltage is approximately 100 V in both discharges. To reduce the anomalous loop voltage which is considered to be due to the anomalous flux loss by the larger shell cut angle (presently 30 degrees), the shell cut optimization is being carried.

The extrapolation of present plasma parameters to the ignition condition needs a substantial extension of present temperature and energy confinement. The progress in high plasma-current and current-density operations and PWI control system is strongly needed[11]. We here estimate and evaluate the ignited plasma parameters in the assumption of simple extrapolation or some modifications of present confinement scaling. A few design works have already been done[12]. But the access to ignition through Ohmic heating only necessitates an another consideration beyond a simple thermal equilibrium. If we assume the poloidal beta value of ignited RFP plasma is still constant and is around 10 %, the minimum plasma current sustaining the ignited plasma is approximately in the range of 10 to 20 MA. We calculate some cases of plasma current density and particle density. In each case the poloidal divertor needs a certain scale which must satisfy the limit of deposition power density. The existence of divertor needed for that class will limit the scale of compactness of RFP. If we admit the value of heat density at the divertor plate surface is the same with the ITER design, the minimum scale of core plasma (approximately 2m of minor diameter) is comparable with the divertor structure scale. When the toroidal divertor is introduced instead of the poloidal divertor, the scale of the toroidal divertor limit the minimum aspect ratio of torus again. By considering these situations, we show some designs with the optimized structure.

References

- [1] Krakowski, R.A., et al., LA-UR-93-2870 (1993).
- [2] Sarff, J.S., Almagri, A.F., Assadi, S., Den Hartog, D. J., et. al., Nuclear Fusion 29 (1989) 104.
- [3] Ishijima, D., Iida, M., Masamune, S., et al., Plasma Phys. and Controlled Fusion 37 (1995) 657.
- [4] Hayase, K., Sato, Y., Hattori, K., 3rd IEA/RFP Workshop (Stockholm, 1993).
- [5] Hayase, K., RFP Panel Meeting (Padova, 1993).

- [6] Hayase, K., 4th IEA/RFP Workshop (Padova, 1995).
- [7] Hattori, K., Hayase, K., Sato, Y., Sugisaki, K., 15th IAEA Conf. on Plasma Phys. and Controlled Nuclear Fusion Research, IAEA-CN-60/CP-7 (Seville, 1994).
- [8] Hattori, K., Sato, Y., Hayase, K., Watanabe, M., Umemoto, T., Irie, M., Sugisaki, K., 16th IAEA Fusion Energy Conf., IAEA-CN-64/CP-14 (Montreal, 1996).
- [9] Hattori, K., Sato, Y., Umemoto, T., Hayase, K., Irie M., 1996 Int. Conf. on Plasma Phys., 1642 (Nagoya, 1996).
- [10] Hayase, K., Hattori, K., Sato, Y., 1996 Int. Conf. on Plasma Phys., 658 (Nagoya, 1996).
- [11] Hayase, K., Now & Future 11 (1996) 9.

IAEA Technical Committee Meeting on
Innovative Approaches to Fusion Energy
October 20-23, 1997, Pleasanton, CA, USA

**TWO NOVEL COMPACT TOROIDAL CONCEPTS
WITH STELLARATOR FEATURES**

P. E. Moroz

Center for Plasma Theory and Computation
University of Wisconsin-Madison
1500 Engineering Drive, Madison, WI 53706, USA

Abstract

Two novel compact toroidal concepts are presented. One is the Stellarator-Spheromak (SSP) and another is the Extreme-Low-Aspect-Ratio Stellarator (ELARS). An SSP device represents a hybrid between a spherical stellarator (SS) and a spheromak, or it can be viewed as a steady-state spherical tokamak (ST) without a center post. This configuration retains the main advantages of stellarators such as steady-state operation, and of spheromaks of not having any material structures in the center of the torus, and has a potential for improving the spheromak or ST concepts regarding their main problems. The MHD equilibrium in an SSP with very high β of the confined plasma is demonstrated. Another concept, ELARS, represents an extreme limit of the SS approach, and considers devices with stellarator features and aspect ratios $A \approx 1 - 1.4$. We have succeeded in finding ELARS configurations with extremely compact, modular, and simple design compatible with significant rotational transform, large plasma volume, and good particle transport characteristics.

Stellarator-Spheromak.

Significant potential payoff of a spheromak as a fusion reactor has sustained the spheromak research for many years (see, for example, [1-7]). Spheromaks differ markedly from many other toroidal systems as they do not have any material structures such as magnet coils or conducting walls linking the torus. Because of attractiveness of spheromaks as a base concept for a fusion reactor, there were a number of reactor-relevant studies (see, for example, [4-6]) stressing various advantages of spheromaks. Among them are compact and simple magnetic field geometry with a natural divertor, supporting the high energy density plasma, nearly force-free ($\mathbf{J} \times \mathbf{B} \approx 0$) equilibrium minimizing stresses, and a simply connected fusion blanket. Because of relatively small size and engineering simplicity, initial capital cost of a spheromak-reactor is estimated to be substantially lower than that based on the other more standard approaches such as standard tokamaks, stellarators, or RFPs. However, the experimentally obtained spheromak plasmas are short-living, even when they are confined in thick solid-wall high-conductivity flux conservers. The main presently recognized problems of spheromaks are the difficulty of plasma start-up and steady-state operation, and the tilt/shift instability.

The discussed here SSP concept [8,9] has a potential for improving the spheromak approach to fusion regarding the above mentioned difficulties while maintaining its main advantages such as compact design and absence of material structures in the center of the torus. Actually, an SSP is a non-axisymmetric spheromak where the outboard stellarator windings (OSW) [10] are used to produce the stellarator effects and a strong outboard magnetic field. On the other hand, an SSP can be viewed as a steady-state ST without a center post. Steady-state regime is supported by the strong bootstrap current. This resolves the main ST problems of the center post which is a subject of very high loads of heat, particles, and neutrons, and

excessive ohmic power deposition. Below we present a few results of calculations. Three main plasma cross-sections for the high- β ($\beta_0 = 90\%$, $\langle\beta\rangle = 21\%$) equilibrium in an SSP are shown in Fig. 1. This equilibrium corresponds to a moderate toroidal plasma current of 630 kA with a hollow profile. Toroidal plasma current, total rotational transform, and toroidal, Φ , and poloidal, Ψ , magnetic flux profiles are shown, respectively in Fig. 2(a,b,c). It is important to mention that the total rotational transform is above 1 at all radii. Also, the local ι -values in an SSP vary significantly on a flux surface, similar to that in an SS [11].

Extreme-Low-Aspect-Ratio Stellarator.

A relatively recently proposed SS concept [11] includes devices with stellarator features and low aspect ratio, $A \leq 3.5$, which is very unusual for stellarators (typical stellarators have $A \approx 7$ -10 or above, and the lowest aspect ratio stellarators ever built have $A \approx 5$). Strong bootstrap current and high- β equilibria are two other distinguished elements of the SS concept leading to compact, steady-state, and efficient fusion reactor. Different coil configurations advantageous for the SS have been identified and analyzed [10-13]. In this report we present results on novel stellarator configurations which are unusual even for the SS approach. These are the extreme-low-aspect-ratio-stellarators (ELARS), with the aspect ratios $A \approx 1 - 1.4$.

Different coil systems capable of producing the ELARS configurations have been studied, including the helical post stellarators with single, double, or triple helices. A typical plasma in an ELARS is presented in Fig. 3. As one can see, it is an extremely compact configuration. In spite of that, the vacuum rotational transform is fairly high ($\iota_0 \approx 0.15$); its radial profile is shown in Fig. 4. Estimations of the neoclassical transport in ELARS, based on the parameter S , introduced in [14], show significant improvement in particle fluxes in comparison with that for standard stellarators. One more advantage of an ELARS is that its coil system is very efficient for producing strong magnetic fields in the plasma at moderate currents in the coils, similar to that in an ST. At the same time, an ELARS has a number of advantages in comparison with an ST; the most significant one relates to the fact that an ELARS is a stellarator and thus can confine the plasma in a steady-state regime.

Acknowledgments.

This work is supported by the U.S. DOE Grant No. DE-FG02-97ER54395.

References.

- [1] M. N. Rosenbluth, M. N. Bussac, Nucl. Fusion **19**, 489 (1979).
- [2] M. Yamada, H. P. Furth et al., Phys. Rev. Lett. **46**, 188 (1981).
- [3] T. R. Jarboe, F. J. Wysocki, J. C. Fernandez et al., Phys. Fluids **B2**, 1342 (1990).
- [4] R. L. Hagenson, R. A. Krakowski, Fusion Techn. **8**, 1606 (1985).
- [5] K. A. Fowler, J. S. Hardwick, T. R. Jarboe, Com. Pl. Phys. Contr. Fus. **16**, 91 (1994).
- [6] R. M. Mayo, Fusion Technology **30**, 1326 (1996).
- [7] R.H. Cohen, E.B. Hooper et al., LLNL Report UCRL-ID-127002 (1997).
- [8] P. E. Moroz, Sherwood Int. Fusion Theory Conf., Madison, Paper 3C31 (1997).
- [9] P. E. Moroz, "Stellarator-Spheromak", accepted in Phys. Lett. A (1997).
- [10] P. E. Moroz, Nucl. Fusion **37**, 1045 (1997).
- [11] P. E. Moroz, Phys. Rev. Lett. **77**, 651 (1996).
- [12] P. E. Moroz, Phys. Plasmas **3**, 3055 (1996).
- [13] P. E. Moroz, Plasma Phys. Reports **23**, 502 (1997).
- [14] K. C. Shaing, S. A. Hokin, Phys. Fluids **26**, 2136 (1983).

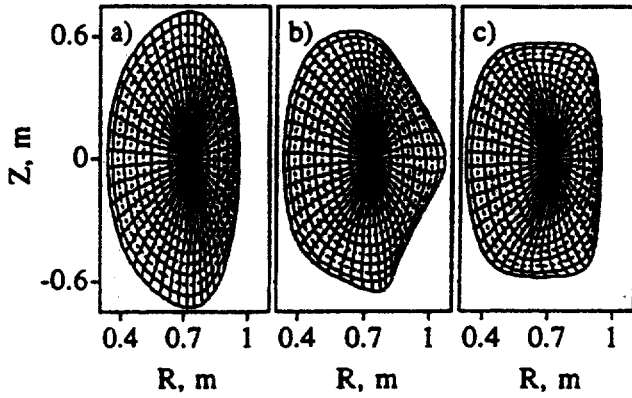

Fig. 1. High- β equilibrium in the SSP,
 $\beta_0 = 90\%$, $\langle \beta \rangle = 21\%$.

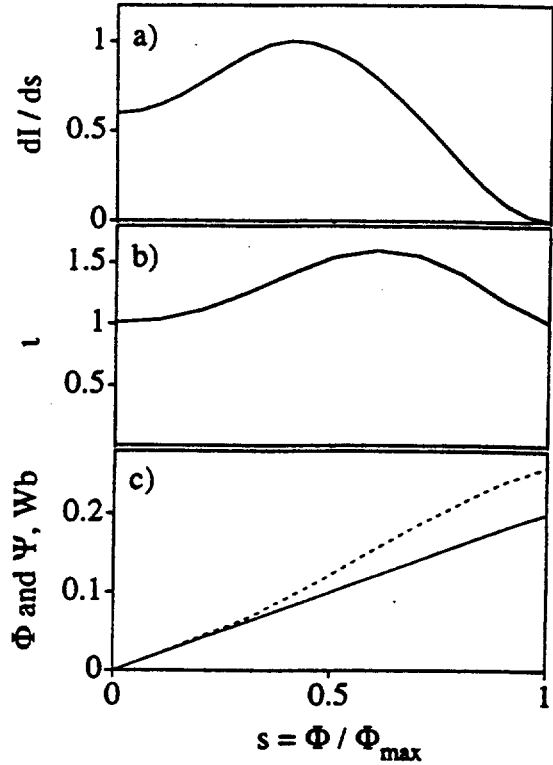

Fig. 2. Radial profiles in the SSP of
 (a) toroidal current density, (b) rota-
 tional transform, (c) toroidal (solid
 line) and poloidal (dashed line)
 magnetic fluxes.

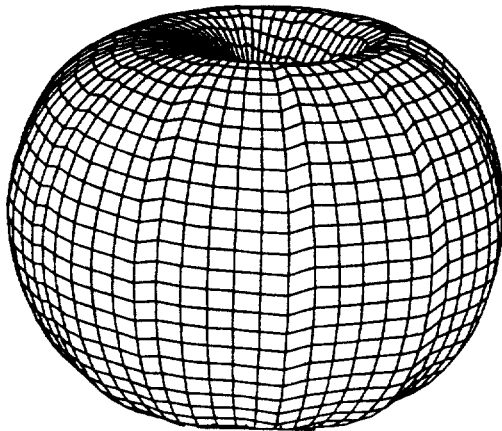

Fig. 3. A typical ELARS plasma.

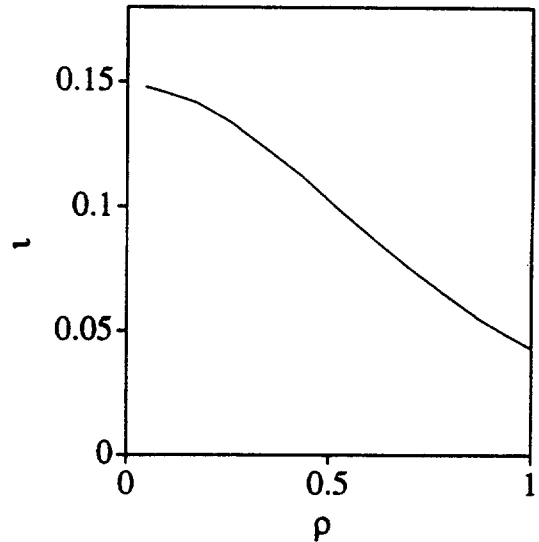

Fig. 4. Radial profile of the vacuum
 rotational transform in the ELARS.

**INERTIAL CONFINEMENT
FUSION**

**Prospects of Inertial Fusion Energy
- Technical and Economical Feasibilities -**

S. Nakai
Institute of Laser Engineering,
Osaka University 2-6 Yamada-oka, Suita, Osaka 565 Japan

Abstract

The basic physics of IFE (compression and ignition of small fuel pellets containing deuterium and tritium) is becoming well understood. New Megajoule laser facilities under construction in the USA and in France are expected to demonstrate ignition and energy gain in the next decade. Fusion reactor design studies indicate that IFE power plants are feasible and have attractive safety and environmental features. The review book *Energy from Inertial Fusion* (IAEA, 1995), was written jointly by 80 experts from around the world in 1991-1994 in recognition of the growing importance of IFE research. In addition recent declassification of many areas of inertial fusion target physics further enhanced the prospects of IFE.

A consultant group was organized to help the IAEA keep abreast of current IFE developments and to guide the Agency in making future programme plans, including means of benefiting Member States that do not yet conduct inertial fusion research.

This report is a personal summary of the international collaborative work on the investigation of the feasibility and of the strategy of Inertial Fusion Energy (IFE).

1. Current Status of IFE Research

High density compression of fuel capsules was demonstrated in the 1980s by laser implosion experiments in the USA and Japan. The way of achieving the fusion product (density \times confinement time) required for ignition has been clarified. In the next step, we have to demonstrate that a hot spark is formed in high density core plasmas to ignite and burn the fuel by fusion reactions. In order to investigate those research issues in the implosion theory and experiment, driver, implosion diagnostic, and pellet fabrication technologies have been developed. The present area of researches on implosion physics is listed below:

- (1.) The following implosion concepts for compression have been explored:
- a. Direct drive (laser or ion beams striking the fuel capsule directly)
 - b. Indirect drive (beams striking a hohlraum to produce x-rays, or dynamic hohlraum based on imploding liner)
 - c. Direct/indirect hybrid drive

Experimental achievements for the above concepts are listed below;

a. Direct Drive

High density compressions have been demonstrated by the multi-beam laser systems in Japan and U.S. The 24 beam laser system, OMEGA at LLE, Rochester achieved 100 B/A ($B=200$ times solid density (20g/cm^3 B/A ($B=40\text{g/cm}^3$, Deuterium Plasma) (1987). The GEKKO-XII laser systems achieved 600 times solid density (600g/cm^3 , CH plasma) compression (1989).

b. Indirect Drive

The NOVA laser system achieved 100 times solid density (20g/cm^3) compression (1986) with the X-ray drive implosion. Volume compression of 103 has been achieved at Iskra-5 laser facilities.

(2.) Methods for igniting the compressed fuel capsule are:

a. Central spark ignition

b. Off-center ignition (fast igniter concept)

c. Volume ignition by stagnation free compression.

Imploded core plasmas have been heated up to higher than 10keV in the high velocity implosion or in the intermediate convergence ratio implosions. The GEKKO XII laser and the NOVA laser have imploded glass micro-balloon filled with DT gas to yield more than 10^{13} /shot neutrons (1986). Recently, the OMEGA-Up-grade at Rochester generated 10^{14} /shot neutrons (1996). In those experiments, the plasma density is the order of the solid density.

In the high convergence implosion, the indirect implosion by NOVA demonstrated the clear core neutron yield up to 20 of radial convergence ratio. However, in the high density implosion experiments, the neutron yield is degraded by a few orders of magnitude in comparison with the 1D simulation prediction.

As for the off-center ignition, experiments on ultra-intense laser-plasma interaction began at many laboratories (Rutherford (UK), LULI (France), ILE (Japan), LLNL (USA) and so on). The laser beams are found to penetrate into very high density plasmas by the hole boring. Further experiments are going on.

(3.) Theory and simulation studies.

An integrated computer code which simulates the implosion and fusion burn process, is developed by taking into account many phenomena in one, two, or three dimensions:

a. Compressible sheared flow hydrodynamics

b. Laser absorption and electron heat transport

c. X-ray radiation heat transport and optical properties of materials

d. Equation of states for plasmas and solid state matter.

e. Liner implosion magnetohydrodynamics

For high gain target design, several integrate implosion simulation codes have been developed both for indirect and direct implosions. The integrated codes for indirect implosion have been developed at LLNL(USA), Limeil (France) and so on. On the other hand, the integrated codes for the direct

drive are under development at ILE(Osaka, Japan), LLE (Rochester, USA), NRL(USA), and so on. The codes are being tested with recent hydrodynamics experimental data.

2. Fusion Reactor Design Study

The IAEA review book "Energy from Inertial Fusion " summarized the reactor design studies and identified the technical issues that are important for the development of inertial fusion energy.

The system composition of IFE power plants and the related design issues are

- (1) driver (efficiency, pulse repetition rate, economics, laser or HIB option etc.)
- (2) pellet fabrication, injection and tracking (required uniformity, measuring and control system of injection and tracking)
- (3) reaction chamber (first wall protection method),(restoration time : re-establishing the wall and chamber condition needed beam propagation and pellet injection), (neutron shielding, protection of final optics)
- (4) remainder which contains system optimization, economics and safety analysis (direct / indirect drive, lasers / ion beams, modular plant design)

The most serious challenges in the design of chambers for inertial fusion energy (IFE) are 1) protecting the first wall from fusion energy pulses on the order of several hundred megajoules released in the form of x rays, target debris, and high energy neutrons, and 2) operating the chamber at a pulse repetition rate of 5-10 Hz (i.e., re-establishing the wall protection and chamber conditions needed for beam propagation to the target between pulses). In meeting these challenges, designers have capitalized on the ability to separate the fusion burn physics from the geometry and environment of the fusion chamber. Most recent conceptual designs use gases or flowing liquids inside the chamber. Thin liquid layers of molten salt or metal and low pressure, high-Z gases can protect the first wall from x rays and target debris, while thick liquid layers have the added benefit of protecting structures from fusion neutrons thereby significantly reducing the radiation damage !

and activation. The use of thick liquid wall is predicted to 1) reduce the cost of electricity by avoiding the cost of electricity by avoiding the cost and doion time of changing damaged structures, and 2) reduce the cost of developing a new, low-activation material. Various schemes have been proposed to assure chamber clearing and renewal of the protective features at the required pulse rate.

Reactor driver is the most crucial issue for the realization of IFE. There are large, active programs worldwide on two laser candidates: diode pumped solid-state lasers (DPSSLs) and gas lasers, mainly KrF and Iodine. For the ion beam driver, ion sources with adequate current and brightness for heavy ion acceleration have been developed. Scaled experiments are underway to demonstrate acceleration and transport of these beams. The specifications which are required for reactor driver are listed as follows.

Lasers

- * energy of several MJ
- * wavelength shorter than 500 nm
- * intensity uniformity of irradiation
- * pulse shaping under saturation amplification
- * spatial control of beams with an imploding target
- * overall efficiency approximately 10% and greater
- * about 10Hz repetitive operation under thermal control
- * affordable capital cost
- * lifetime about 1010 pulses
- * affordable operation and maintenance cost
- * reliability and redundancy of all subsystems

Ion beams and liner implosion

- * high current acceleration maintaining the necessary brightness up to final focusing
- * demonstration of propagation of high-current beams through space charge or current neutralized transport channels to the target
- * demonstration of propagation of high current beam through free space and focusing.
- * high efficiency conversion from electricity to beams
- * high efficiency conversion and confinement of X-ray from beam for pellet implosion.

3. Concluding Remark

The achievement of fusion energy is well in scope to reach, even if it would take long spans toward next century. It is required to consider a strategic approach toward energy production. Research coordination and collaboration of world wide, exchange of informations and open discussions between different concepts of fusion approaches are useful and important for the effective promotion of fusion energy development.

References

- 1) Energy from Inertial Fusion, STI/PUB/944, ISBN92-0-100794-9, IAEA 1995
- 2) Report of the IAEA Consultant Meeting on IFE Activities, to be published
- 3) Private Communication, W.R.Meier, R.W.Moir and M.A.Abdou:Chamber Technology Concepts for Inertial Fusion Energy

Ignition and High Gain with Ultra-Powerful Lasers
Max Tabak
Lawrence Livermore National Laboratory
Livermore, California 94550

Abstract

Ultra-high intensity lasers can potentially be used in conjunction with conventional fusion lasers to ignite inertial confinement fusion(ICF) capsules with a total energy of a few tens of kilojoules of laser light and can possibly lead to high gain with as little as 100 kilojoules. A scheme is proposed with three phases. First, a capsule is imploded as in the conventional approach to inertial fusion to assemble a high density fuel configuration. Second, a hole is bored through the capsule corona composed of ablated material, as the critical density is pushed close to the high density core of the capsule by the ponderomotive force associated with high intensity laser light. Finally, the fuel is ignited by suprathermal electrons, produced in the high intensity laser plasma interactions, which then propagate from critical density to this high density core. This new scheme also drastically reduces the difficulty of the implosion and thereby allows lower quality fabrication and less stringent beam quality and symmetry requirements from the implosion driver. The difficulty of the fusion scheme is transferred to the technological difficulty of producing the ultra-high-intensity laser and of transporting this energy to the fuel.

The plan of the talk is as follows: we first discuss and compare the gain model that describes the conventional approach to inertial fusion with the model that describes our proposed scheme.. Next we address how the laser intensity is to be determined. Then comes a description of the hole-boring scheme. We show a preliminary calculation integrating the various pieces of the scheme at the pre-ignition scale. We also describe a sample of recent experimental progress. Finally, we summarize the work.

If the project succeeds it could have significant impact on the practicality of inertial fusion: driver energy scales could be reduced, and target fabrication finish and irradiation symmetry requirements could be eased. The higher gain curves could support a reactor using high repetition rate small yield explosions or low repetition rate high yield explosions. If successful, the fast ignitor concept would make some driver candidates currently considered unacceptable due to their low efficiency viable as a result of the higher gain achievable. On the other hand, when coupled with high efficiency drivers the high gain possible with this ignition technique could be traded for acceptable gain with a lower tritium concentration in the capsule and a lower fraction yield escaping as neutron energy.

Abstract
Submitted to the IAEA Technical Committee Meeting on
Innovative Approaches to Fusion Energy
October 20-23, 1997
Pleasanton, California USA

Innovative Approaches to Heavy Ion Inertial Fusion -- Revolution or Evolution?

Roger Bangerter
Accelerator & Fusion Energy Division
Ernest Orlando Lawrence Berkeley National Laboratory
University of California
1 Cyclotron Road, MS 47-112
Berkeley, California 94720

Heavy ion inertial fusion was first suggested by Al Maschke more than twenty years ago. Upon hearing of this new concept, a senior magnetic fusion scientist remarked, "The last thing this country needs is another billion-dollar fusion concept." Many members of the heavy ion fusion community understood and appreciated this comment. Consequently, there has been a continual search for accelerator, target, and chamber solutions that lead to better economics and/or environmental characteristics. The heavy ion fusion program was initiated by accelerator scientists who had designed, built, and operated large accelerators. Accelerator technology and beam physics were believed to be relatively mature and well understood -- as long as one did not stray too far from existing experience. The goal was to develop innovative accelerator architectures based on this conservative, well established physics and technology. Neutralization and other techniques that involved plasmas (and plasma physicists) were regarded with suspicion. This conservative philosophy has a number of implications. For example, if one wishes to avoid neutralization and plasmas, the accelerator must produce of the order of 10 GV of acceleration. Using conventional techniques, this voltage leads to relatively large machines, machines that are several kilometers long, although they could be folded to minimize land use. There has been some objection to these large machines. Nevertheless the traditional, conservative heavy ion fusion philosophy has been remarkably successful. The large accelerators would fit on many existing power plant sites. More importantly, heavy ion fusion studies such as HIBALL, Osiris, Prometheus-H, and HYLIFE-II predict costs of electricity, at 1 GWe, that are lower than those predicted for tokamaks and nearly all other inertial fusion options. The scaling of heavy ion fusion to plant capacities larger than 1 GWe is very favorable, because one accelerator can drive multiple chambers. The inertial fusion option that has predicted electricity costs at 1 GWe comparable to, or sometimes lower than, heavy ion fusion is light ion fusion. It is instructive to examine the light ion fusion program. In many ways, the light ion program has taken an approach that is the diametrical opposite of the heavy ion approach. Light ion fusion has always required neutralization and plasma physics. The light ion program has focused its resources on understanding and controlling these phenomena and on developing new accelerator technologies to exploit them.

Based on two decades of experience, it now appears (at least to me) that the light ion approach may have pushed too far into speculative physics. It also appears that the conservative, purist heavy ion approach could push farther. The restructuring of the U.S. fusion program has given new impetus to investigate systems that lie between the two extremes. Moving away from the ends of the periodic table to a more central position is one of several approaches to a better fusion system.

Most studies show that the driver (accelerator or laser) is the single most expensive component of an inertial fusion power plant. In developing systems that are better than those

envisioned under the historical conservative approach, we first consider what can be done to improve the accelerator. There are at least four approaches to better accelerators:

1. Reduce the target requirements. While this is not strictly an accelerator issue, there are target concepts that lead to smaller, less expensive accelerators. For example, heavy ion fusion has usually assumed that the targets would be indirectly driven. Direct drive, gives approximately twice the target energy gain at approximately half the driver energy.
2. Reduce the accelerator length. One way to do this is to reduce the accelerator voltage. Since the targets are designed to work at a specified ion range, reduced voltage implies reduced ion mass or increased ion charge state. Neutralization and plasma physics become important. This is the approach that seeks to move to a middle ground between light and heavy ions. A second way to reduce the length is to increase the acceleration gradient. Preliminary calculations show that this approach is feasible. It can be validated with inexpensive, small-scale experiments.
3. Reduce the cost per meter. We are exploring a number of improvements in physics and technology that will lead to a less expensive accelerator structure. These improvements will be described.
4. Change accelerator architecture. In the traditional induction linac approach to heavy ion fusion, the ferromagnetic material in the induction cores has been an expensive item. Architectures such as microtrons and recirculators reduce the quantity of ferromagnetic material. Livermore is currently performing experiments on recirculation.

In my opinion, no one has identified a single magic solution that will, by itself, lead to a quantum jump in the performance-to-cost ratio of the accelerator. On the other hand, it is likely that steps described above, taken together, can lead to a solution that is more attractive than solutions based on the older, more conservative philosophy. In this sense, I expect the path to heavy ion fusion to be more evolutionary than revolutionary.

From a magnetic fusion standpoint, there is a tendency to lump all inertial options together. As noted above, there have been important differences between the heavy ion and light ion programs. Laser fusion is also different. Because of the relatively low efficiency of lasers, it is difficult, with presently predicted target energy gain, to achieve an attractive recirculating power fraction. For lasers, the success of the fast ignitor, a speculative target concept that may lead to higher target gain, would lead to significant improvements in economics. Consequently there is enormous worldwide interest in the fast ignitor. Fast ignition might also help heavy ion fusion. Indeed, target concepts very similar to the fast ignitor were part of Maschke's original proposals. In any case, heavy ion fusion does not appear to need the fast ignitor to achieve good economics.

In addition to driver improvements, there are a number of improvements in chambers, focusing systems, and energy conversion that warrant more study. These will be discussed.

Beam Dynamics for Heavy-Ion Fusion

**Alex Friedman
Lawrence Livermore National Laboratory
University of California
P.O. Box 808, Mail Stop L-645
Livermore, California 94550**

For Heavy-Ion Fusion (HIF) to be economically attractive, it is desirable to accelerate beams with a very large line-charge density, of order 0.1 to 10 micro-Coulombs per meter or greater. Such "space-charge-dominated" beams are non-neutral plasmas, and must be confined against their own electric fields and thermal pressure as they are accelerated. The techniques used to analyze and simulate these beams were derived from those of both MFE plasma physics and traditional accelerator physics. In this paper we review these methods, and point out some areas where a better understanding would be desirable.

The D-T capsules in fusion targets envisioned for HIF are virtually identical to those planned for the National Ignition Facility and the French MegaJoule Project. Thus, the most challenging aspects of HIF target design center around developing suitable hohlraum geometries with radiation converters and other elements strategically placed so that the capsule is illuminated symmetrically with the desired pulse shape, and with minimal losses to the hohlraum itself. A number of geometries appear feasible, and (in general) are calculable with the same tools used for NIF target design. Ion beam stopping in hot matter is believed to be no worse than classical, and can be explored with off-line experiments. Ultimately, the target designs set the beam requirements, and in general show that it is highly desirable to be able to focus the ion beams onto small (few mm scale) spots, for them to have a relatively short stopping range, and for the pulses to be relatively short (of order 10 ns in the main pulse) as well.

Thus, development of a suitable cost-effective driver with the required beam current and brightness is generally deemed the pacing item for heavy-ion Inertial Fusion Energy (IFE). The U.S. is developing advanced induction accelerators (both linear and circular) because induction technology inherently supports high-current beams. The European and Japanese programs are developing radiofrequency linacs, which are lower-current devices and so must feed a set of storage rings to accumulate enough beam particles. In each case, the desire is to accelerate and/or transport as much current as possible through a system of modest cross-section and lineal cost.

These beams, while (because they are composed of heavy ions) relatively rigid, nonetheless display a broad range of plasma phenomena, both fluid and kinetic. The behaviors which must be understood include instabilities which must be avoided, kept under control, or possibly exploited. Since the beams emerge from the ion source with a low temperature, preservation of beam quality (focusability) at a low enough cost is the principal issue. In magnetic fusion the goal is to heat the plasma to about 10 keV. In heavy ion fusion the goal is to keep the beam from heating to > 1 keV.

Coordinated experiments, analysis, and simulation address the physics issues of space-charge-dominated beams. The experiments enjoy excellent shot-to-shot repeatability, so that one can collect data over many shots, to develop a detailed description of the beam particle distribution $f(x,v,t)$. Furthermore, the achievable good accuracy in emittance measurements implies that one can study slow emittance growth processes in short experiments. In analytic theory, the techniques employed are similar to those used in other branches of plasma physics, and many useful approximate models are employed: smooth focusing, thin lens, smooth acceleration, etc. For discrete-particle computer simulation, in a limited sense the task is relatively "easy" because the beam plasma frequency is only $\sim 10^6 \text{ s}^{-1}$, while the linac acceleration time is of order 10^{-4} s , implying only ~ 100 plasma periods need be followed. However, in these systems the fastest frequencies are associated with particle motion through external field variations, and timesteps must be in general much less than the plasma period. Thus, "end-to-end" simulation of a fusion driver is a true grand-challenge class activity. Such simulation is a major goal of the program, and considerable progress has been made, some of which is described in this talk.

Thus, the HIF beam physics program is advanced through closely-coupled experiment, simulation, and analytic theory. A key goal is a suite of well-validated models that enable confident projections. In my opinion, we are taking a balanced approach that is consistent with the priorities of the restructured U.S. Fusion Energy Sciences Program.

MIRRORS

PLASMA CONFINEMENT IN GAMMA 10 AND TANDEM MIRROR REACTOR

K. YATSU, L.G. BRUSKIN, T. CHO, M. HAMADA, M. HIRATA, H. HOJO,
M. ICHIMURA, K. ISHII, A. ITAKURA, I. KATANUMA, Y. KIWAMOTO, S. KUBOTA,
A. MASE, S. MIYOSHI, Y. NAKASHIMA, T. SAITO, T. TAMANO, Y. TATEMATSU,
M. YOSHIKAWA

Plasma Research Center, University of Tsukuba, Tsukuba, Ibaraki 305, Japan

1. INTRODUCTION

In the tandem mirror GAMMA 10, the plug and thermal barrier potentials of 1.7 kV and 1.1 kV have been attained with the plasma confinement time of 0.6 sec [1]. After the attainment of the 1.7 kV plug potential, the theme of the GAMMA 10 research shifted to raise the ion temperature by increasing the ICRF power and attained the ion temperature of 10 keV with $\beta=10\%$ [2]. This operation mode is called hot ion mode. However, the high plug potential and the high ion temperature are not attained simultaneously. The present issue of the GAMMA 10 experiment is the simultaneous attainment of the high plug potential and ion temperature.

The confinement of the high ion temperature plasma is explained by the mirror confinement in the central cell. To study the role of the potential confinement of the high ion temperature plasma, the end-loss ion currents in both ends were measured in detail by a newly developed end-loss-ion energy analyzer (ELA)[3] for one side plugging and both sides plugging. The potential plugging of passing ions has been clearly shown in this experiment. However, some radial loss of passing ions in the anchor and plug/barrier cell is observed in the hot ion mode. The process of the radial loss is under investigation and possible measures to reduce the radial loss will be taken.

In this paper, the experimental results of potential confinement in GAMMA 10 are presented and the future prospects of a tandem mirror reactor are described.

2. STUDY OF POTENTIAL CONFINEMENT IN GAMMA 10

The GAMMA 10 tandem mirror consists of a central cell, two anchor cells and two end mirror cells. The anchor cells with minimum-B configuration are located in both ends of the central cell and are connected to the end mirror cells. Ions in the central cell are heated by a slow ion cyclotron wave excited by a pair of double half turn antennas installed at near both ends of the central cell. Ions in the anchor cells are also heated by another ion cyclotron waves with frequencies different from that in the central cell. The anchor hot ions assure MHD stability of a GAMMA 10 plasma. A positive plug potential is formed in the axisymmetric end mirror cells by fundamental ECRH. The axial magnetic field strength and locations of each heating system are shown in Fig.1(a).

The wave forms of end loss ion current and central cell line density are shown in Fig. 1(b) and (c). When ECRH is applied only west side plug, the ion current of the west side ELA (W-ELA)

decreases due to the potential reflection, while that of the east side ELA (E-ELA) increases. When ECRH is applied to both sides, the central cell line density (NLCC) increases mainly due to the plugging. The plasma parameters near axis in the central cell were as follows. The plasma density n was $1.5 \times 10^{18} \text{ m}^{-3}$, electron temperature T_e was 90 eV and ion temperature T_i was 4 keV. The E-ELA current shown in Fig. 1(c) decreases when both plug potentials are formed and then gradually increases corresponding to the increase in NLCC. When ECRH is turned off, there is a short burst in the ELA current due to the axial drain out of the confined plasma. However, the ELA current during ECRH is smaller than the current before and after ECRH. This suggests an existence of some amount of radial loss of the passing ions during the time when both ECRH and ICRF are applied.

The radial loss is estimated from the one end plugging data (Fig. 1(b)). The decrease in the W-ELA current during ECRH is due to the potential reflection and the radial loss. From the current decrease and the current increase in E-ELA, the reflection ratio (plugging) was determined to be 60% and the one-pass radial loss of the passing ion was 9% for this shot, where the plugging potential ϕ_e was 170 V and the parallel temperature of the end loss ion was 330 eV. During these experiments, the radial loss was several to ten percents and the reflection ratio of up to 65% was obtained. The radial loss tend to decrease when the ECRH and ICRF heating patterns were more axisymmetrically adjusted.

The loss mechanism and the region where the loss taking place have not been identified. The confinement time of the central cell plasma was estimated to be close to the classical mirror confinement time. So, the mechanism of the passing-ion radial loss is not affecting to the central cell confinement. We consider that the loss is taking place in the anchor region and/or the plug/barrier region. We suspect the regions of fanning minimum-B field, where the circular flux tube of 0.4 m in diam. at the central cell midplane maps to $0.025 \text{ m} \times 1.4 \text{ m}$ elliptic tube. Some

Fig.1 Axial magnetic field strength (a), and wave forms of ELA and NLCC (b) and (c).

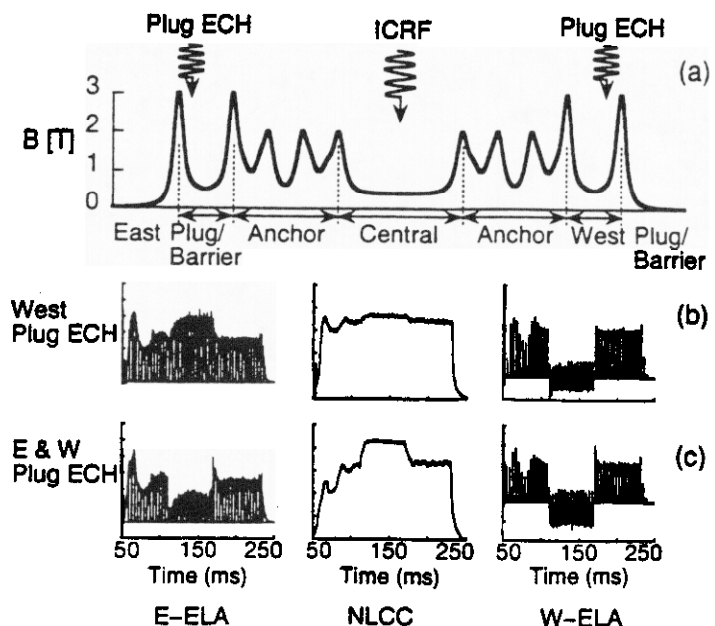

Figure 1(b) shows the case when only the west side plug potential is formed, while (c) shows the case when both plug potentials are formed.

irregular electric field possibly occurring in the hot ion mode causes the radial loss by the $E \times B$ drift in those regions due to the short distance across the plasma. In addition to the adjustment of the ECRH and ICRF heating patterns, a conducting wall will be installed near the surface of the fanning magnetic flux tube to fix the potential at the plasma boundary for reducing the possible irregular electric field.

3. TANDEM MIRROR REACTOR AND MAGNETIC FIELD CONFIGURATION

The plasma confinement in the central cell of GAMMA 10 was nearly classical. The Q-value of a single mirror reactor of classical confinement is close to unity. The GAMMA 10 experiments showed the confinement improvement over the single mirror confinement by the potential plugging. So, a tandem mirror reactor has a good prospect to obtain a Q-value larger than unity.

As a tandem mirror magnetic field, we proposed a non-localized minimum-B field configuration which can avoid the technical difficulty due to the strong magnetic field repulsion force of the minimum-B field [4]. The diameter of the central cell can be made arbitrarily large with the new magnetic field configuration. Since the anchor cells are eliminated, the plug and barrier potentials can be formed in separate cells in a five mirror cells tandem mirror as the original idea [5]. The plug potential and the barrier potential are independently controllable by separating the two cells.

4. CONCLUSIONS

The GAMMA 10 experiments clearly showed the potential plugging in the case $\phi_c/T_i=0.5$. Several measures will be taken to reduce the radial loss of the passing ions during the time when both ECRH and ICRF are applied. The non-localized minimum-B field is proposed as a tandem mirror magnetic field configuration. A tandem mirror reactor is very attractive by a possible high β value, direct energy conversion and inherent steady state operation. Since, a good prospect has been obtained for improved confinement in tandem mirrors, tandem mirror experiments and tandem mirror reactor studies should be strongly promoted.

REFERENCES

- [1] MIYOSHI, S., et al., in Plasma Physics and Controlled Nuclear Fusion Research 1990 (Proc. 13th Int. Conf. Washington, D.C., 1990), Vol.2, IAEA, Vienna (1991) 539.
- [2] TAMANO, T., et al., in Plasma Physics and Controlled Nuclear Fusion Research 1994 (Proc. 15th Int. Conf. Seville, 1994), Vol.2, IAEA, Vienna (1995) 399.
- [3] SAKAMOTO, Y., et al., Rev. Sci. Instrum. 66 (1995) 4928.
- [4] YATSU, K., et al., Plasma Phys. Report 23 (1997) 774.
- [5] BALDWIN, D.E., LOGAN, B.G., Phys. Rev. Lett., 43 (1979) 1318.

EXPERIMENTAL STUDIES OF PLASMA CONFINEMENT AND HEATING IN THE GAS-DYNAMIC TRAP

**A.V.ANIKEEV, P.A.BAGRYANSKY, P.P.DEICHULI, A.A.IVANOV,
A.N.KARPUSHOV, A.LIZUNOV, V.V.MAXIMOV, I.V.SHIKHOVTSEV,
N.V.STUPISHIN, Yu.A.TSIDULKO, S.V.MURAKHTIN, K.NOACK¹, G.OTTO¹**
Budker Institute of Nuclear Physics, 630090, Novosibirsk, Russia

1 INTRODUCTION

The studies on the gas-dynamic trap (GDT) are focused on generation of plasma physics database for the GDT-based 14 MeV neutron source (GDT-NS) [1,2] dedicated for fusion materials test. In the GDT-HS, plasma is confined in a long axisymmetric magnetic trap with high mirror ratio. The neutron source plasma is essentially two component. The isotropic, relatively cold component is collisional. In addition, the hot anisotropic tritons and deuterons are produced in the trap by neutral beam injection at a skew angle at the center of the device. These ions are confined in a kinetic regime. In order to obtain fast ion density peaks near the mirrors (where most of the neutrons are produced) their angular spread should be relatively small during slowing down in the plasma. The injection of fast ions is also used to compensate collisional energy losses through the mirrors. For magneto-hydrodynamic stability of the entire plasma it is important that this collisional flux feeds high enough density plasma in the regions beyond the mirrors where the field line curvature is favorable for stability. Correspondingly, macroscopic stability of the two components plasma contained in the axisymmetric magnetic field and micro-stability of the anisotropic fast ions are of prime concern in the studies.

2. EXPERIMENTAL APPARATUS

The GDT facility [3,4] consists of a 7m axially symmetrical central cell bounded from each ends by min-B cells of an expander and cusp configurations. Plasma in the cusp is fed by the central cell plasma losses through the linking mirror. Additional plasma gun was used to vary plasma density in the cusp independently. Typically, density in the cusp was 3-10% of that in the central cell. Magnetic field at the midplane is 0.22T, mirror ratio is variable in the range 12.5 - 75. Initial plasma in the central cell, which density is varied in the range $10^{19} + 2 \cdot 10^{20} \text{ m}^{-3}$, is produced by plasma gun located in the end tank. The plasma is pulsed with each "shot" lasting from 3-5 ms. In order to heat up the gun-produced plasma and to provide energetic ions, six neutral beams are injected at the midplane at 45° to the axis. Total injected power of 15-16 keV neutral beams was up to 3.5MW in 1.2ms pulses.

2. MACROSCOPIC STABILITY OF PLASMA WITH FAST IONS

Sloshing ion density (mean energy of 3-6 keV) accumulated during 3.5MW neutral beam injection reaches 10^{19} m^{-3} in the vicinities of the turning points. Thomson scattering data typically indicate the central cell electron temperatures $\approx 100\text{eV}$. The measured charge-exchange lifetime of the sloshing ions exceeds 10ms, so that these losses are negligible in the plasma energy balance. The MHD stability studies involved measuring energy and particle losses from the central cell for various ratios of the central cell plasma pressure to that inside the cusp end cell. To quantify stability property of the plasma, we have used the data on fast ions and bulk plasma energy contents in conjunction with measurements of transverse energy losses to radial limiters, longitudinal losses through the mirrors and charge-exchange losses [3,4].

It was observed that by varying plasma pressure inside the cusp, the entire plasma can be made stable or unstable. Beside significant difference in plasma temperature ($T_e = 80\text{-}140\text{eV}$ in stable regimes and $15\text{-}20\text{eV}$ in unstable ones, correspondingly) and fast ion density in the these regimes, the conclusion

can be drawn that in the MHD stable regime plasma is essentially lost longitudinally ($\approx 70\%$) whereas in the unstable one transverse losses dominate.

3. LONGITUDINAL ENERGY LOSSES

Generally, from measurements of the plasma energy balance no evidence has been found of an additional cooling of the central cell plasma due to contact to the end walls. In separate experiments, near axis segment of the end wall was substituted by a plate which can be moved along the axis. When heated, the plate served to deliver cold electrons into the plasma, so that the emitted current density exceeded that of the plasma electrons. The plasma parameters in the near-axis region in the central cell were measured for different positions of the plate in expander and for different current densities emitted by the plate. It was observed that when the distance between the plate and the mirror exceeded certain value which corresponds to the magnetic field reduction 20-40 times (theory predicts it would occur for $\sqrt{m_e/M_i}$ field reduction [5,6]), the plasma parameters in the central cell were unchanged. Whenever it was closer, significant reduction of the temperature occurred, thus indicating increase of heat conduction to the plate. Longitudinal energy loss rate were measured and compared with the theory [1, 2]. The data are summarized in Table 1 (the theoretically predicted values are given in the parenthesis).

Table 1

Parameter	Value
energy per ion-electron pair carried to the end wall	$8.7 \pm 1.8 T_e$ (7.2+8.2 T_e)
mean energy of ions striking the wall	$6.3 \pm 0.1 T_e$
electron mean energy near the wall	$0.3 \pm 0.15 T_e$
potential drop in expander	$4.6 \pm 0.1 T_e$

4. CHARACTERIZATION OF FAST IONS

To characterize the sloshing ions containment, their experimentally measured parameters were compared with those obtained by Monte-Carlo and Fokker-Plank simulations. It was presupposed that their relaxation rates in given plasma background are defined by Coulomb scattering solely.

It was noted that the simulations agree rather well with the experimental observation. The angular spread of the fast ions, averaged over the plasma volume, is also quite close to that theoretically calculated [3]. The local fast ion distribution over energies was measured at the center of the device at an angle of 45° to the axis. These data are in reasonable agreement with results of calculations within the accuracy of the measurements ($\pm 15\%$).

5. CONCLUSION

In the regimes with the cusp end cell and mirror ratio of 12.5 confinement in the GDT is almost completely determined by collisional losses through the mirrors as expected. No anomalies in sloshing ions relaxation in the target plasma have been observed so far.

6. REFERENCES

- [1] MIRNOV, V.V., RYUTOV, D.D., Sov. Tech. Phys. Lett. , 5 (1979) 279.
- [2] RYUTOV, D.D., Plasma Phys. and Controlled Fusion 32 (1990) 999.
- [3] ANIKEEV, A.V., BAGRYANSKY, P.A., Bender E.D., et al., in: Proc. of 22nd EPS Conf. on Contr. Fusion and Plasma Phys., Bournemouth, UK, 1995) Vol.19C, part IV, 193-196.
- [4] IVANOV, A.A., et al., Phys. of Plasmas 8 5 (1994) 1529-1536.

- [5] KONKASHBAEV, I.K., LANDMAN, I.S., ULINICH, F.R., Sov. JETP, 74, 3 (1978).956 (in Russian)
- [6] MIRNOV, V.V., RYUTOV, Preprint BINP 88-70 (1988) (in Russian)

Open-Ended Systems: Some Possible New Directions

Richard F. Post

Lawrence Livermore National Laboratory

Among magnetic fusion approaches, fusion power systems based on an open-ended magnetic field topology, e.g., mirror-based systems, possess many desirable features from a practical viewpoint. Among these desirable features is the efficiency with which they can utilize the confining field (MHD-stable at high beta), the relief from wall-loading problems that comes from their natural diverter action (particle loss channel out the ends), and their consequent ready adaptability for the use of high-efficiency direct converters. In addition, as a result of now nearly 50 years of study, the physics of plasma confinement in mirror-based open-ended systems is very well understood. This understanding comes from the theoretical tractability of open systems, theory that is corroborated with a solid experimental data base.

In a search for innovative approaches the magnetic topology of open-field systems also permits the consideration of a far wider spectrum of fusion-relevant alternatives than does closed field geometry. Specifically, closed systems such as the tokamak have well-known plasma physics constraints (low beta, turbulence-enhanced diffusion, etc.), have difficult physical access, and suffer problems associated with the "one-dimensional" nature of their particle losses. That is, because particle losses in such systems are necessarily purely radially directed, the plasma is forced to terminate radially at a close-coupled, turbulent, "edge plasma" within which the heat flux to the bounding wall is large and in which the plasma temperature drops precipitously. All of these problems are either alleviated or do not appear in open-ended systems.

In this paper some examples of one subset of possible new open-ended systems will be considered. This subset might be called "linear colliders," analogous to the long colliding-beam systems used by particle physicists in their investigations. In the past several decades the high-energy particle accelerator community has shown the practicality of constructing, and operating and maintaining, long (up to 27 km) underground particle accelerator and collider facilities employing superconducting magnets and rf systems operating in a high vacuum environment. These elements represent many of the same basic ingredients that would be employed in a long linear open-ended fusion system, one that would be located in an underground tunnel of the same order of dimensions as existing colliders and accelerators. With such experience as a guide, one can then investigate the practicality of designing a fusion power plant of similar geometry, i.e., a system in which the fusion power is generated in a long solenoid (in the examples to be given, up to 30 kilometers in length). If we assume that the physics and technology issues posed by such systems are solvable, then the question of practicality become mainly one of cost. As the accelerator community has already shown, operation of their facilities in underground tunnels solves one major problem for such large-scale facilities, namely, location. Example: The 27 kilometer-long LEPC collider at CERN in Switzerland passes under residences and farm land in both Switzerland and France without any negative impact on the use of the land above it.

In the spirit of pointing out potentially promising areas for further investigation we will sketch two examples of open-ended "linear collider" fusion power systems. In both examples the basic field geometry will be that of a long solenoidal field with ion sources and direct converters located at the ends to accomplish fueling and energy recovery of charged particle energy (charged reaction products and un-fused ions). Both systems are therefore examples of "low-Q," fusion power systems in which the achievement of useful net fusion power is dependent on achieving high efficiency in both the ion injection and the direct-recovery systems. As such these fusion power systems are analogous to their mechanical counterpart, the gas turbine. Gas turbines represent a successful power generation system in which the amount of internally recirculated power is large compared to the net power output.

In order to perform a preliminary estimate of the cost of the plants involved we will assume that the dominant cost of each system is that of the superconducting solenoid and its ancillaries. In the absence of a detailed study we will take as a guide cost analyses that have been made for large-scale solenoidal SMES (Superconducting Magnetic Energy Storage) systems for

electric utility use [1]. These studies give the projected cost for SMES systems, based on long solenoids contained in underground tunnels, storing amounts of magnetic energy comparable to the magnetic energy in the solenoidal fields of our linear colliders. For the examples to be presented the magnetic fields will range from 5 Tesla to 10 Tesla and the magnet inner diameters will range between 1 and 2 meters. For a 30 kilometer-long solenoid these parameters will imply magnetic energy levels between 2.3×10^{11} Joules at the low end and 3.75×10^{12} Joules at the high end. From Figure 5 of Reference 1, the "first-of-a-kind" cost for a complete solenoidal-coil SMES system storing the larger of these amounts of magnetic energy is given as approximately $\$1 \times 10^9$. For our 30 kilometer solenoid this would amount to about \$30,000 per meter. For purposes of estimating, and in an attempt to be conservative in the absence of a detailed cost estimate, we will take for our fusion system a cost figure that is 5 times higher, namely, \$150,000 per meter. This figure can be used to make a rough estimate of the generated electric power per meter of the solenoid needed to amortize the cost of the fusion power system over an assumed operating lifetime of 20 years. At an 85 percent operating factor for the plant, 20 years corresponds to about 150,000 hours of revenue-earning time. If we assume that an averaged figure of \$.02/kWhr of the power plant's revenue can be devoted to amortizing its cost, then this implies that the plant must generate about 50 kWe per meter to produce the required revenue rate. At an assumed plant efficiency of 33 percent, this then amounts to 150 kW of fusion energy release per meter of the solenoid, for a total electrical power of 1500 MWe from the plant.

The linear collider examples we will discuss represent extensions of previously published studies [2, 3, 4]. In these earlier studies it was visualized that high-density plasma streams would be launched from the ends of the tube, to collide and fuse, followed by the exit of the injected particles into direct converters. The numbers involved would have placed great demands on injector and direct converter technology. In the present examples we will attempt to employ some well-established mirror physics to alleviate these problems, thereby requiring a lesser extrapolation of present ion source technology to achieve the plasma conditions required. Some calculations relating to the two examples to be discussed here are contained in a forth-coming publication [5].

The two examples that will be given lie at opposite ends of a continuum of possible systems. However, both employ the same configuration of magnetic field, namely, a long solenoid the magnetic field of which monotonically decreases in approaching the ends. Such a field configuration, in which the field lines flair outward in approaching the ends, has favorable field-line curvature and is therefore stabilizing against MHD modes. Furthermore, being axially symmetric it does not give rise to the kinds of resonant cross-field transport that can occur in non-axi-symmetric mirror fields.

Example I is a pure linear collider in which the required high density of the colliding beams is achieved by the "magnetic compression" that occurs when ion beams injected nearly parallel to the field lines at the ends are compressed radially by the converging magnetic field lines. Equations are presented that define stability boundaries for this compression. These boundaries, taken to be associated with the "firehose" instability, determine the ion source, direct converter, and magnetic field parameters needed to achieve the above-defined required net fusion power output per meter of the solenoid. The field geometry and the short residence time of the particles in such a collider is such as to minimize its plasma confinement requirements. The effect is therefore to shift the burden away from concern about plasma confinement and stability issues to some well-defined technological problems.

Example II is based on the "two-ion-component" mirror concept [6]. In this concept a high-density target plasma, for example containing deuterons, is employed. Through this plasma pass injected high energy ions, for example, tritons, at a lower particle density. The new concept involved here, dubbed the "kinetic tandem," concerns the means by which it is proposed to contain the target plasma. It represents a different means by which to accomplish the objective of the original tandem mirror concept of Dimov [7] and Fowler and Logan [8]. In their original concept the end losses of a long central mirror cell were to be electrostatically plugged by positive potential barriers to be generated in short auxiliary mirror cells located at each end. To generate

these potential barriers a plasma-physics aspect of mirror confinement was employed - the positive ambipolar potential that automatically arises in bringing equality between the loss rates of electrons and ions. By maintaining plasmas in the end cells at densities higher than that of the plasma in the central cell the required plugging potentials are automatically generated. In the "kinetic tandem" it is proposed to achieve the same objective by creating a "sloshing ion" distribution, in the manner employed, for example, in tandem mirror experiments in Novosibirsk [9]: Injecting ions up the magnetic gradient at the ends of the solenoid at pitch angles such that they are reflected at a position before the magnetic field has reached its maximum value will result in the formation of density peaks that can emulate those in the Dimov/Fowler-Logan tandem mirror end cells and thereby create the potential maxima needed to contain a target plasma.

Mirror theory was used to perform an approximate analysis of the kinetic tandem concept, taking into account two requirements for plugging: potential generation and axial momentum (axial pressure) transfer. In a conventional tandem the magnetic gradients in the mirror cells perform the latter function, providing a means to transfer the axial pressure exerted by the target plasma (through the ambipolar electric field) to the structure. In the kinetic tandem this function must be performed by the longitudinal momentum input delivered by the injected ion streams. Equations are derived that define the injected beam and magnetic field parameters required to satisfy both of the above requirements at practical target plasma densities and temperatures, consistent with the constraints imposed by the firehose instability.

The material to be presented is for the purpose of illustrating some possibly promising new avenues for future investigations in the quest for fusion power. The calculations presented are necessarily approximate and incomplete. It is hoped, however, that they will help to stimulate a new interest in open-ended systems for fusion power purposes. The underlying philosophy involved is that approaches to fusion power that minimize the requirements for plasma confinement, while maximizing the present theoretical, computational and experimental base for understanding that confinement, should have the best prospects for achieving fusion power in a timely manner. Open-ended systems are alleged to be prime candidates for such a role.

Work performed under the auspices of the U. S. Department of Energy by the Lawrence Livermore National Laboratory under contract No. W-7405-Eng-48

References:

- [1] C. A. Luongo, IEEE Trans. on Magnetics, **32**, 2214 (1996)
- [2] R. F. Post, in *Physics of Alternative Magnetic Confinement Schemes* (Proc. of Workshop at Varenna, Italy, 15-24 October 1990) Societa Italiana de Fisica, p. 63 (1991)
- [3] R. F. Post, Ibid. p. 833
- [4] R. F. Post, D. D. Ryutov, in *Proc. of First International Symposium on Current Trends in International Fusion Research*, p. 153 (Plenum Press, New York, 1996)
- [5] R. F. Post, "Open Systems in the Quest for Fusion," Plasma Physics Reports (in press)
- [6] R. F. Post, T. K. Fowler, J. Killeen, Phys. Rev. Lett. **31**, 280 (1973)
- [7] G. I. Dimov, V. V. Zakaidakov, M. E. Kishinevskii, Sov. J. Plasma Physics. **2**, 326 (1976)
- [8] T. K. Fowler, B. G. Logan, Comments Plasma Phys. Controll. Fusion **2**, 167 (1977)
- [9] A.A. Ivanov, in *Physics of Alternative Magnetic Confinement Schemes* (op. cit. p. 443)

D-He³ TANDEM MIRROR APPROACH

T. TAMANO, L.G. BRUSKIN, T. CHO, M. HAMADA, M. HIRATA, H. HOJO, M. ICHIMURA,
K. IKEDA, K. ISHII, A. ITAKURA, K. KAJIWARA, I. KATANUMA, Y. KIWAMOTO, J. KOHAGURA, S. KUBOTA, A. MASE, Y. NAGAYAMA¹, Y. NAKASHIMA, N. OYAMA, Y. SAKAMOTO, T. SAITO,
S. TANAKA, Y. TATEMATSU, T. TOKUZAWA, K. YATSU, M. YOSHIKAWA, Y. YOSHIMURA¹

Plasma Research Center, University of Tsukuba, Tsukuba, Ibaraki 305, Japan

¹ Present address: National Institute for Fusion Science, Toki, Gifu 509-52, Japan

N. SATO, R. HATAKEYAMA, T. KANEKO

Department of Electronic Engineering, Tohoku University, Sendai, Miyagi 980-77, Japan

M. INUTAKE, M. YOSHINUMA

Department of Electrical Engineering, Tohoku University, Sendai, Miyagi 980-77, Japan

Y. YASAKA

Department of Electronics, Kyoto University, Kyoto 606, Japan

Recent research associated with a tandem mirror system has made a remarkable progress [1-6]. Although further studies need to be done in order to establish a proof of principle for a tandem mirror fusion approach, it seems to remain as a viable option for a fusion reactor. One of attractive features of a tandem mirror system is a potential candidate for a D-He³ fusion reactor. Interests for a D-He³ system are keep increasing as fusion plasmas with tens of keV have been achieved in several devices. It has also been recognized that handling a large amount of fusion neutrons in a D-T system is not an easy task. Neutron production in a conventional D-He³ system can be reduced to a few hundredth of that in a D-T system. Recently, a possibility of further reduction of neutron production has been discussed [7, 8]. In this paper, we examine tandem mirror D-He³ fusion reactor approaches based on implications obtained from the recent tandem mirror research.

A tandem mirror has several unique features. One of them is reduction of end losses by forming plug/thermal barrier potentials. In the earlier tandem mirror proposals use of neutral beam injection was suggested for potential formation. However, recent progresses in basic research associated with tandem mirror experiments have demonstrated formation of plug/thermal barrier potentials with electron cyclotron resonance heating (ECRH) alone and subsequent reduction of end losses [1, 3-5], which provides a wide range of flexibility in considering a tandem mirror reactors. This implies that quasi-neutrality of the plasma and ambipolar end losses is established in a tandem mirror [9-11]. It is also shown that the potential for the axial confinement also produces radial electric fields and that plasma fluctuations due to drift instabilities are suppressed and radial confinement has improved. [2, 3, 6, 12]. The other significant result is confinement of 10 keV anisotropic plasmas and fusion neutron production in GAMMA10 [3, 4]. Therefore, it is worth while to apply implications of the recent results to a tandem mirror reactor approach. Since an application of anisotropic plasmas to a D-He³ reactor is discussed in details as a two component approach in Ref.[8], we consider a steady state D-He³ reactor and compare with the two component system in this paper. There are two main parts in our considerations. One is a microwave power requirement for the potential formation. The other is effects of the potential formation on plasma stability and confinement.

In a D-He³ system all fusion products are charged particles .



Some of the fusion products are immediately lost since they are born in a loss-cone, but most of them are mirror- trapped and transfer their energies to D, He³ and electrons. Therefore, a heating rate of a D-He³ plasma by fusion products in a steady state condition is about the same as that in a D-T system, where 80 % of the D-T fusion energy is carried out by neutrons although the maximum fusion reaction rate is about 5 times that in a D-He³ system. The fusion energy is transferred to the ions and electrons and the transfer ratio is determined by an electron temperature. If the fusion product energy is 15 times the electron temperature or more, more energy is transferred to electrons. Under a conceivable steady state D-He³ system, an electron temperature is not high enough so that more energy transfers to electrons. In this case the energy transfer time is comparable to the electron-ion equipartition time. Accordingly, a fair amount of the transferred energy is shared by ions through the electron channel.

In order to produce enough fusion energy, we like to have an ion temperature as high as practically possible. On the other hand, present-day experiments indicate that particle losses to the end is nearly ambipolar. That is, axial energy confinement times for ions and electrons must also be about equal. Therefore, a steady state electron temperature must be somewhat higher than ion temperature and the electron energy confinement time needs to be longer than the equipartition time. This places a necessary constraint on an enhancement factor due to potential confinement. The enhancement factor

over the electron collision time τ_e is approximately given by $\frac{\phi_b}{T_e} \exp \frac{\phi_b}{T_e}$,

where ϕ_b is a thermal barrier potential and T_e is an electron temperature. Therefore, the constraint becomes

$$\frac{\phi_b}{T_e} \exp \frac{\phi_b}{T_e} \geq \frac{M_i}{m_e},$$

where M_i and m_e are ion and electron masses, respectively. This means $\frac{\phi_b}{T_e} \geq 6$, which has been demonstrated in the present-day experiments.

Let us now evaluate a power required for this potential formation. The results from the present day experiments [4, 11] indicate that

$$\frac{\phi_b}{T_e} \propto \frac{P_\mu}{n},$$

where P_μ is a microwave power for the potential formation and n is a plasma density. In other words, $\frac{\phi_b}{T_e}$ is proportional to the microwave power per particle. The $\frac{\phi_b}{T_e}$ value required for a reactor

system is about the same as that obtained in a GAMMA10 hot ion mode where P_μ is about 100 kW at $n = 2 \times 10^{18} \text{ m}^{-3}$. Therefore, a power required for a D-He³ system is estimated to be about 10 MW and 50 MW at $n = 2 \times 10^{20} \text{ m}^{-3}$ and 10^{21} m^{-3} , respectively. These values are rather encouraging. However, in this estimate we assume the same plasma configuration as the GAMMA10 device. This is one of the largest uncertainties at present. One needs to investigate the power requirement in different size plasmas in future. The other question is whether there is any ceiling for the actual potential value. Effects of relativistic electrons must be considered.

Since

$$\frac{n_F W_F}{\tau_F} \sim \frac{n T_e}{\tau_{E_i}} \sim \frac{n T_i}{\tau_{E_e}},$$

and

$$\tau_F \sim \tau_{E_i} \sim \tau_{E_e}$$

pressures of the fusion products, plasma electrons and plasma ions are comparable:

$$n_F W_F \sim n T_e \sim n T_i$$

Here, n_F and W_F are density and energy of the fusion product. This indicates that none of a single component causes a particularly high pressure, but that the system is not a very high Q system.

One of the very favorite results from the present-day experiments is reduction of plasma fluctuations due to radial electric fields [2, 6, 12]. These radial electric fields are naturally created when the axial confinement potentials are formed. End plate/limiter biasing experiments indicate that drift waves are suppressed by the radial electric fields regardless of the sign of the electric fields. This suggests a similar mechanism as that for a tokamak H-mode, i.e., suppression of instabilities due to sheared ExB plasma rotations. This same stability effect can be expected in a tandem mirror reactor system. However, it is also experimentally observed that a flute type mode is excited with a large electric field. In this case positive large electric fields excite the flute mode. This may be expected because of a large ExB plasma rotation. If the large plasma rotation is the cause of the flute mode, excitation of this mode may also be expected with large negative electric fields. However, the latter has not been observed in some experiments [12]. We will discuss possible reasons for the difference including an effect of ∇p_i [13] and will suggest a way to create negative radial electric fields in a D-

He³ reactor with a slightly higher $\frac{\phi_b}{T_e}$.

In conclusion, implications from the present-day results seem to support requirements for a D-H³ tandem mirror fusion reactor. Furthermore, an advantage of a straight magnetic system with no large toroidal drift of high energy components has been proven in very anisotropic plasma confinement experiments in GAMMA 10, which relates to the two component tandem mirror scheme to further reduce the neutron production [8].

References:

- [1] M. INUTAKE, et al., in Plasma Physics and Controlled Nuclear Fusion Research 1992 (Proc. 14th Int. Conf. Wurzburg, 1992), Vol. 2, IAEA, Vienna (1993) 651.
- [2] A. MASE, et al., Nucl. Fusion **31** (1991) 1725.
- [3] T. TAMANO, et al., in Plasma Physics and Controlled Nuclear Fusion Research 1994 (Proc. 15th Int. Conf. Seville, 1994), Vol. 2, IAEA, Vienna (1995) 399.
- [4] T. TAMANO, Phys. Plasmas **2** (1995) 2321.
- [5] T. SAITO, et al., to be published in Proc. 16th IAEA Fusion Energy Conf. Montreal, 1996, IAEA, Vienna.
- [6] O. SAKAI, et al., Phys. Rev. Lett. **70** (1993) 4071.
- [7] N. HERSHKOVITZ, et al., Nucl. Fusion **30** (1990) 1761.
- [8] D.D. RYUTOV, in Proc. 2nd Symposium on Helium-3 and Fusion Power (1993) 121.
- [9] Y. TATEMATSU, et al., J. Phys. Soc. Jpn. **63** (1994) 558.
- [10] I. KATANUMA, et al., Phys. Plasmas **4** (1997) 2532.
- [11] T. KANEKO, et al., in Bulletin 14th Annual Mtg Jpn. Soc. Plasma Science Nucl. Fusion Research (1997) 288.
- [12] M. YOSHINUMA, et al., in *ibid.* (1997) 94.
- [13] IKEDA, et al., Phys. Rev. Lett. **78** (1997) 3872.

**Z-PINCHES AND PLASMA
FOCI**

DEVELOPMENT OF DOUBLE LINER SCHEME DYNAMIC HOHLRAUM FOR PELLET IGNITION .

Smirnov V. P. Grabovski E. V. Nedoseev S. L. Olejnik G. M. Zacharov S. V.
TRINITI

Double Liner (DL) (another name is Dynamic Hohlraum) concept was proposed in Ref. 1. It permits to convert liner kinetic energy to radiation pulse with a duration being significantly less than a generator pulse duration.

Theoretical and experimental studies of DL with ANGARA-5-1 were carried out and first results were reported in Ref. 2, 3.

Double Liner is a cascade system of two coaxial liners with high charge ($Z \gg 1$) substances (Ref. 1). The external liner accelerated by a magnetic field pressure collides with the internal one. A thermal X-ray radiation generated by a high-velocity shock wave ($V = 4-5 \cdot 10^7$ cm/s), penetrates into the internal liner cavity and irradiates a target like in hohlraum. The external liner realizes an energy confinement at the same time, hindering radiation escape outside, thereby reaching the radiation intensity increasing in the hot cavity. The inner liner serves both to stagnate the imploding outer plasma, converting plasma kinetic energy into radiation, and hydrodynamically isolate the target from the imploding plasma before its ignition.

To convert effectively the liner kinetic energy into radiation and to realize the energy confinement the liners should be produced of substances with high charge $Z \gg 1$. As it was shown Ref. 4, a thermal pressure of liner multi charged plasma is much less than magnetic one because of high radiation losses. Therefore, during the liner implosion its thickness is compressed up to skin-layer scale ($d = (c^2 t / 2ps)^{1/2}$).

The liner kinetic energy is determined mainly by the current amplitude (I) and the convergence ratio (R/r , where R - initial radius and r - final one)

$mV^2 / 2 \propto \alpha I^2 h \cdot \ln(R/r)$, where m , V - outer liner mass and velocity, h - its length, α - coefficient depending on particular current pulse shape.

The external liner acceleration is accompanied by radiation of energy dissipated in the liner plasma. As a result, the internal liner sublimates from irradiation and disintegrates with the sound velocity. During collision, the external liner's deceleration and conversion of its kinetic energy into radiation occurs with characteristic time

$$\tau = \delta / V.$$

1-D numerical simulations predict that for the generator parameters with current amplitude $I = 15$ MA and voltage pulse rise time 100 ns the liner with mass 2.8mg and radius $R = 1.65$ cm accelerated up to the velocity $V = 5 \cdot 10^7$ cm/s may be enough for the 2mm diameter cryogenic target ignition Ref. 9. As a result of collision with the internal liner with mass 4.5mg and radius $r = 0.2$ cm, the cavity of inner liner is filled by thermal radiation with an intensity on the target $W = 500$ TW/cm² and pulse duration at a half-height $t = 3.7$ ns. The liner kinetic energy grows with convergence ratio increasing. But MHD instabilities restrict the convergence ratio at 10 - fold level ($R/r < 10$); hence, the kinetic energy flux is limited. The external liner instability in the process of acceleration affects on the radiation pulse duration due to a width of the first cascade liner, as well as on the energy confinement efficiency in the cavity due to discontinuity of the external liner optical thickness.

Various types of plasma instabilities for a multicharged ion current driven plasma of liners may take place:

- an ionization instability in the early discharge stage Ref. 7,
- a thermal instability at the initial stage of plasma current heating Ref. 5,
- a thermal-radiating instability as a prolongation of the previous one on the stage of a radiation-heating equilibrium Ref. 6,
- a nonisothermal instability after the first shock wave Ref. 6, 8,
- MHD instabilities (like Raleigh-Taylor mode) with distinctions for the multi charged plasma.

-anomalous resistance of liner plasma due to different types of micro instabilities.

Influence of instabilities and anomalous resistance reduces with current growth under fixed convergence ratio because of plasma becomes unmagnetized and electron drift velocity decreases for higher liner densities.

The problem of energy trapping in the imploding liner cavity (we may call it Dynamic Hohlraum effect) as well as radiation transparency of inner liner substance, which play an important roll in the energy balance of a radiation production and target irradiation efficiency demands the optimization of liner plasma spectral properties with taking into account of non-LTE effects especially for low 3-10MA current experiments. For higher currents and for ignition experiment the plasma density have to be large enough to decrease non-LTE effects.

Significant efforts are directed now onto 2-D simulations and experimental examinations of the Double Liner to study influence of instabilities at the initial and implosion stages as well as nonequilibrium effects.

The experiments to verify the double liner concept were performed on Angara-5-1 facility with 3,5-4,5 MA current. 32 mm diam xenon gas puff with Mach number 6 was used as an external liner with specific mass 100-200mkg/cm. The internal 4 mm diam liner was produced from 5-10 mg/cm³ density foam doped by .1-1.0 mkm Mo powder. In spite of instability development during implosion of outer liner soft X-ray measurements reveal a significant sharpening of radiation pulse from cavity. Radiation rise time reached 3-5 ns and its intensity up to 3 TW/cm². Some screening radiation by outer liner was observed. Comparison of simulations with experimental result permit to explain the differences in temperature and radiation pulse duration by instabilities and zipper effect.

The following activity on double liner scheme development was directed on the increasing the uniformity of implosion. The results will be discussed in the paper.

Present situation in Russia pushed a search of low cost approaches to developing of multi megajoule facility for pellet ignition. In TRINITI and Efremov institute the possibility to use the constructed 900 MJ inductive store of T-14 tokamak was analyzed. This scheme will be briefly presented in the paper.

REFERENCES

1. Zakharov S.V., Smirnov V.P. et.al. Collision of Current Driven Cylindrical Liners. Kurchatov Institute of Atomic Energy. Moscow. Preprint 4587/6, 1988.
2. Smirnov V.P., Grabovskii E.V., Zaitsev V.I., Zakharov S.V. et.al. Progress in Investigations on a Dense Plasma Compression on ANGARA-5-1. Proc. of BEAMS'90. World Scientific, 1991. V.1, p.61(I.07).
3. Zakharov S.V., Smirnov V.P., Tsarfin V.Ya. ANGARA-5 High Intensity Soft X Ray Source with Imploding Liner Cascade for Inertial Confinement Fusion. Proc. of 14th Int. Conf. on Pl. Phys. and Cont. Nuc. Fus. Res. Wurzburg, 1992. IAEA. Vienna, 1993. V.3, p.481 (IAEA-CN-56/G-3-9).
4. Grigoriev S.F., Zakharov S.V. Magnetohydrodynamics of Strongly Radiative Plasma of Liners. Sov. J. Tech. Phys. Lett. 13, 254 (1987).
5. Vikharev V.D., Zakharov S.V., Smirnov V.P. et.al. Influence of Preionization Effect on the Acceleration Dynamics of Radiative Plasma Flux in High Current Discharges. Sov. J. Pl. Phys. 16, 388 (1990).
6. Branitskii A.V., Vikharev V.D., Zakharov S.V. et.al. Investigations of the Liner Compression Initial Stage on ANGARA-5-1 Device. Sov. J. Pl. Phys. 17, 311 (1991).
7. Velikhov E.P., Pismenny V.D., Rakhimov
8. Gasilov V.A., Zakharov S.V., Panin V.M. Influence of Azimuthal Instabilities on the Acceleration Dynamics of Radiating Liners. Preprint IAE 5464/6, 1992.
9. Zakharov S.V., Lisitsyn A.G., Evseev G.A., Maslyankin V.I. Dynamics of a target implosion under action of the liner radiation. Preprint IAE-5581/6. Moscow. 1993

UNSOLVED PROBLEMS AND FUTURE PROSPECTS OF PLASMA-FOCUS RESEARCH

Marek Sadowski
Soltan Institute for Nuclear Studies
05-400 Otwock-Swierk n.Warsaw, Poland

This invited talk concerns some important but unexplained problems met in research on high-current pulsed discharges of the Plasma-Focus (PF) type. Such discharges are sources of intense X-ray pulses, fast electron beams, and high-energy ion beams consisting of primary gas ions as well as impurity- and admixture-ions [1-12]. From the PF discharges performed with the deuterium filling there are also emitted fast neutrons and protons from D-D fusion reactions. Under some conditions products of D-T reactions can also be observed.

The optimization studies of various PF facilities have been performed in different plasma laboratories for many years [4-15], but there are still some important problems to be solved.

To determine scaling laws of the PF discharges and to optimize the neutron emission from nuclear fusion reactions there were performed numerous experiments, including comparative studies of different facilities, e.g. those of the PF 360-kJ device in Swierk and the large POSEIDON 500-kJ facility in Stuttgart [13]. Although a promising scaling of the neutron yield (Y_n versus the 2nd power of energy stored or the 4th power of current intensity) was observed for energies ranging up to about 500 kJ, it was found that Y_n saturates or even decreases when the charging voltage and the initial energy input as well as the discharge current are increased to values above certain critical values. Different methods were proposed to overcome the neutron saturation, e.g., by changes of the electrode configuration, by preionization of the working gas, etc., but results were negative. However, the replacement of a glass insulator in POSEIDON by a ceramic tubing, as used in the PF-360, improved the situation considerably [13]. When the initial energy was increased from 250 kJ (at 60 kV) to 500 kJ (at 80 kV) only a partial saturation was observed and Y_n reached 2.5×10^{11} neutrons/shot, but deviations from the scaling were again registered at higher energy levels.

Other experiments were performed with the pulsed injection of an additional gas into the focus region in order to decouple the final discharge phase from the initial one and to discern the role played by local gas conditions during the radial collapse [14]. It was shown that POSEIDON can be operated in a controlled way, and Y_n can even be increased by about 30%. The best results were obtained with an improved gas nozzle (tilted towards the z-axis), and with the deuterium puffing under determined experimental conditions Y_n was even increased by 80% [15]. The optimization can thus be

performed not only by changes in the current-sheath formation conditions (e.g. by a choice of an appropriate insulator and its conditioning), but also by the modification of the final compression (e.g. by the gas puffing into the focus region). An amount of the puffed gas should be chosen appropriately to the PF system configuration and energetics. It means that the neutron saturation effects require more detailed theoretical and experimental studies.

In some PF facilities there were also performed studies of energetic ions (emitted mostly along the z-axis) and fast electron beams (emitted in the up-stream direction). In many cases very fast ions of energy up to several MeV, i.e. considerably higher than an interelectrode voltage, were registered [7-12]. It was shown that the high-energy ion beams are ejected mainly from small local sources, while lower energy ions are emitted from more extended plasma regions. It was proved experimentally that the ion acceleration is caused by very strong local electric fields [9-10], but although different acceleration mechanisms were proposed there is no theoretical approach able to explain all the known ion emission characteristics [9-13].

Important information about the structure of PF discharges is gained from X-ray emission studies. At high discharge currents (> 800 kA) X-ray pinhole pictures demonstrate the appearance of quasi-axial filaments extending along the whole pinch column [16]. It was shown that such filaments cannot be induced only by an eventual primary filamentation of the current sheath. Depending on experimental conditions, the axial filamentation can be very distinct, although it does not seem to influence strongly fusion reactions (neutrons and secondary protons). At lower discharge currents the structure of a pinch column is quite different. There are formed small brilliant regions called "hot-spots" [7, 17]. The quasi-axial filaments and/or hot-spots are interesting non-linear phenomena and they have not fully been explained so far.

The formation of hot-spots and the generation of fast electron beams are evidently coupled [17]. Detailed X-ray spectroscopic studies, as performed in particular for PF discharges with deuterium filling and argon admixtures, revealed the emission of different X-ray lines corresponding to highly-ionized species. Some assessments of electron concentration and temperature values were also performed. Recent X-ray measurements have revealed an evident difference between intensities of the same X-ray lines registered by means of two similar spectrographs with the crystal dispersion planes perpendicular mutually [18]. This effect can be explained by the polarization of the studied X-ray lines, caused possibly by interactions of fast electron beams with a dense plasma.

In general, although PF studies have been performed in many plasma laboratories (all over the world) the problems described above have not been solved so far. Therefore, they require further detailed investigations to

reveal physical mechanisms of the phenomena in question and to facilitate the optimization of future PF facilities.

Several new large-scale PF experiments were proposed, ranging from the PF 1000-kJ facility under testing at the IPPLM in Warsaw, Poland [19], to several-MJ PF experiments run in Moscow, Russia [20]. All those experiments have produced so far discharge currents below several MA. Recently a new very large scale PF experiment with an inductive storage system has been proposed [20], in which currents above 20 MA could possibly be reached, provided that appropriate funds are granted by Russian authorities and other interested partners.

A more realistic PF project, although still not approved, is connected with the International Centre for Magnetized Plasmas (ICDMP) Proposal which was elaborated under auspices of UNESCO [21]. This proposal showed that the collaborative effort is needed to perform studies of strong nonlinear and turbulent phenomena in DMPs (e.g., those observed in PF discharges), to establish training and exchange of technology between developed and developing countries, and to identify possible applications. The PF configuration was proposed as the initial DMP load for a 1-MJ facility, because PF pulsed power technology (based on 10-100 kV capacitor banks) is less complicated and less costly than sophisticated megavolt power technologies, and it enables a larger number of discharges to be performed. On the other hand, in opinion of members of the International Working Group (representing 16 different countries) there is no real necessity to go to multi-MJ PF experiments now.

The ICDMP Proposal was published and distributed all over the world [21]. Several countries (in a chronological order - Italy, Poland, China, Romania, and Argentina) offered a site and some equipment, and the Steering Committee for ICDMP was established at UNESCO in 1994.

During the Meeting of Representatives of Governments and Governmental Agencies, which was held in Prague, Czech Rep., on October 9, 1995, the representatives of 8 countries endorsed the proposal and they gave their views or offers of the participation in ICDMP activity. There were also presented opinions on the location of the Centre. A general preference was expressed for locating it in Europe, but the question remained unsolved because it depends on future funding. All the declared contributions have amounted so far to one third of the total funding. The ICDMP proposal was also considered by the IAEA Advisory Group Meeting held in Vienna on Sept. 3-5, 1996, and it was submitted to the IAEA authorities. The present status of the proposal is a subject of the Steering Committee Meeting in Palaiseau, France, on Sept. 18-20, 1997. New offers from Poland and Romania have just been presented. In particular the PF facilities operated in Poland (i.e., MAJA-PF 120-kJ and PF 360-kJ devices run in Swierk, as well as PF 1000-

kJ facility tested in Warsaw, together with special diagnostic equipment) have been declared as open for the international scientific collaboration and an eventual basis for ICDMP. Future prospects depend on official declarations and real inputs expected from interested countries and/or international institutions as IAEA and UNESCO.

References:

1. N.V.Filippov, T.I.Filippova, V.P.Vinogradov; Nucl. Fusion Suppl.2 (1962) 577.
2. J.W.Mather; Phys. Fluids Suppl. 7(1964) 5.
3. S.J.Stephanakis, L.S.Levine, S.Mosher, et al.; Phys.Rev. Lett. 29(1972) 568.
4. K.D.Ware, A.H.Williams, R.W.Clark; Bull. Amer. Ph. Soc. 18(1973) 1364.
5. A.Bernard, A.Coudeville, A.Jolas, et al.; Phys. Fluids 18(1975) 180.
6. S.Kaliski, J.Baranowski, M.Borowiecki, et al.; J. Techn. Phys. 16(1975) 387.
7. H.Krompholz, L.Michel, K.H.Schonbach, N.Fisher; Appl. Phys. 13(1977) 29.
8. R.Gullickson, H.Sahlin; J. Appl. Phys. 49(1978) 1099.
9. L.Bertalot, H.Herold, H.Jager, A.Mozer, et al.; Phys. Lett. 79A(1980) 389.
- 10 M.Sadowski, H.Schmidt, H.Herold; Phys. Lett. 83A(1981) 435.
- 11.G.Gerdin, W.Stygar, F.Venneri; J. Appl. Phys. 52(1981) 3269.
- 12.M.Sadowski, J.Zebrowski, E.Rydygier, et al.; Phys. Lett. 113A(1985) 25.
- 13.H.Herold, A.Jerzykiewicz, M.Sadowski, H.Schmidt; Nucl. Fusion 29(1989) 1255.
- 14.H.Schmidt, M.Sadowski, et al.; Plasma Phys. Contr. Fusion 36(1994) 13.
- 15.H.Schmidt, M.Sadowski, et al.; J. Techn. Phys. 38(1997) 121.
- 16.M.Sadowski, H.Herold, H.Schmidt, H.Shakhatre; Phys. Lett. 105A(1984) 117.
- 17.L.Jakubowski, M.Sadowski, E.Baronova; Proc.ICPP'96 (Nagoya 1996) Pt.2, p.181.
- 18.L.Jakubowski, M.Sadowski, et al.; Proc. 4th ICDZP (Vancouver 1997), C1-03.
- 19.M.Scholz, M.Borowiecki, et al.; Proc. ICOPS'97 (San Diego 1997), 2P41.
- 20.N.V.Filippov; Proc. ICOPS'97 (San Diego 1997), 3E02-03.
- 21.International Centre for Dense Magnetised Plasmas: A Proposal (UNESCO 1995).

Dense Plasma Focus Dynamics

H.M.Soliman and M.M.Masoud
Plasma and Nuclear Fusion Department
Nuclear Research Center
Atomic Energy Authority
Egypt

SUMMARY

The study of the plasma sheath dynamics in axial phase and the effect of transverse magnetic field on the dynamics and parameters of the focused and expanded plasma have been carried out in a 3 KJ coaxial system of Mather type.

Measurements showed that the plasma sheath is splitted into two layers at the breech, which is referred to as a shock front and its magnetic piston. It has been found that the two layers of the plasma current sheath rotate around the inner electrode. At the muzzle the back layer reverse its rotation direction due to the magnetic field structure of the system. Results showed that the axial velocity of the first layer is greater than the second one all over the axial phase within the range between 1.4 and 1.7 .

The experimental results have shown that the plasma flow along the expansion chamber axis is restricted when applying the externally transverse magnetic field of intensity 280 G and the maximum axial velocity of the expanded plasma is decreased by 33 % .

X - ray probe has been used to measure the focused plasma electron temperature (T_e) . The experimental results and calculations showed that T_e is decreased from 2.2 Kev to 800 ev with the application of transverse magnetic field.

The plasma sheath structure of a powerful plasma focus (20 KJ) has been investigated by means of the measurements of the axial and azimuthal magnetic fields along the coaxial electrodes.

Prof. Dr. Hanaa M. Soliman
Head of Plasma Focus Group

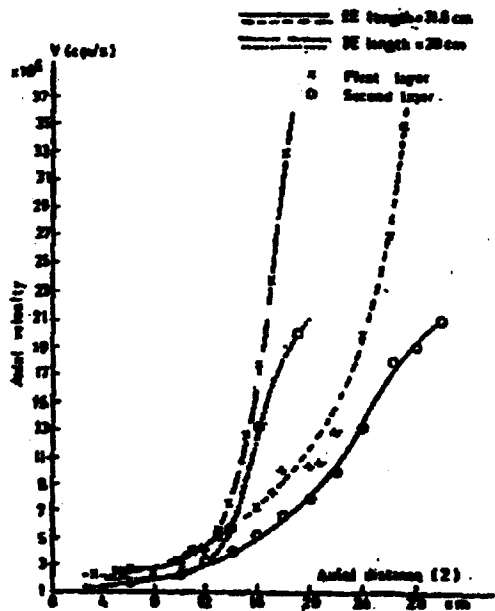

Fig. 1 The axial velocity of the leading and back layers versus the axial distance from trench end. For IE length = 20 cm and 21.5 cm.

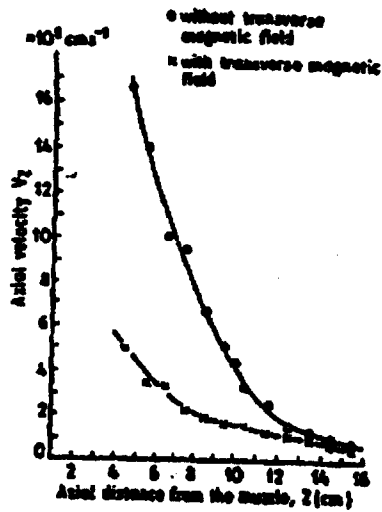

Fig. (3) The axial plasma shell velocity, V_z , versus the axial distance (z) scale.

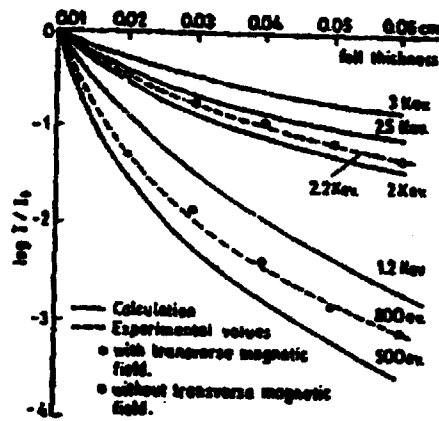

Fig. 2 Theoretical transmission curves for Al filter for different values of electron temperature and fitting of experimental points.

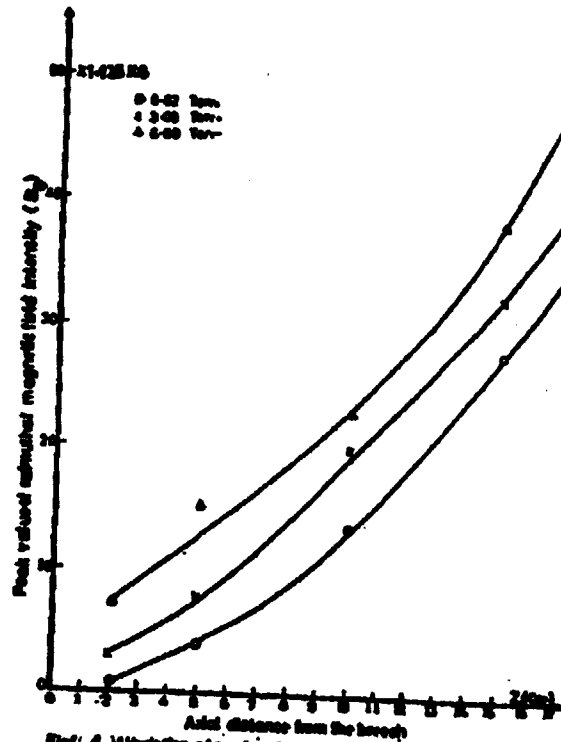

Fig. 4 Variation of peak value of absolute magnetic field intensity versus axial distance from the nozzle.

References

1. Donges, A. , Herziger, G. , Krompholtz, H. , Rohl, F. and Schonback , K.
Phys. Letters , 76A, 391 (1980)
2. Bernard, A. , Garconnet, J.P. , Jolas, A. , Breton, J.P.L.E. and De Mascureau, J.
International Conf, on Plasma Phys. and Controlled Nuclear Fusion Research, 159 (1987).
3. Moo, S.P. , and Lee, S.
J. Phys., 4, 131 (1987)
4. Chang, C.T.
Plasma Phys. , 13 , 1067 (1971)
5. Masoud, M.M. , Soliman, H.M., and El-Khalafawy, T.A.
A.R.E./ A.E.E. Rep 294 (1986)
6. Soliman, H.M. , Masoud, M.M., and El-Khalafawy, T.A.
XVIII ICPIC, Contrib. Pap.2, 432 (1987)
7. Masoud, M.M.
Ph.D. thesis, Faculty of Science, Cairo university, (1971)
8. Kemp, N.H., Petschek, H.E.
Physics of Fluids, 2, 899 (1959)
9. Soliman, H.M.
Arab J. Nucl. Sci. and Appl. 2 (1994) 139.

**POSTER SESSION 1:
PULSED FUSION SYSTEMS,
ICF, TECHNOLOGY**

Abstract
IAEA Technical Committee Meeting on Innovative Approaches to Fusion Energy
October 20-23, 1997
Pleasanton, California USA

Induction Accelerators for Heavy Ion Fusion: Architectures and Options

J.J. Barnard¹, R.O. Bangerter², A. Faltens², T.J. Fessenden², A. Friedman¹,
E.P. Lee², B.G. Logan¹, S.M. Lund¹, W. Meier¹, W.M. Sharp¹, S.S. Yu²

¹Lawrence Livermore National Laboratory, Livermore, CA 94550

²Lawrence Berkeley National Laboratory, Berkeley CA 94720

The approach to heavy-ion-driven inertial fusion which has been studied most extensively in the U.S. uses induction modulators and cores to accelerate and confine the beam, in contrast to rf systems, which are being considered in other countries. The intrinsic peak-current capabilities of induction machines, together with their flexible pulse formats, provide a suitable match to the high peak-power requirement of a heavy-ion fusion target. However, as in the rf case, where combinations of linacs, synchrotrons, and storage rings offer a number of choices to be examined in designing an optimal system, the induction approach also allows a number of architectures among which choices must be made.

We review the main classes of architecture for induction drivers that have been studied to date. The main choice of accelerator structure is that between the linac and the recirculator, the latter being composed of several rings. Hybrid designs are also possible. Other design questions include which focusing system (electric quadrupole, magnetic quadrupole, or solenoid) to use, whether or not to merge beams, and what number of beams to use--all of which must be answered as a function of ion energy throughout the machine. Also, the optimum charge state and mass must be chosen. These different architectures and beam parameters lead to different transverse and longitudinal emittance budgets and imply different constraints on the final focus. The advantages and uncertainties of these various architectures will be discussed.

* Work performed under the auspices of the U. S. Department of Energy at LLNL under contract W-7405-ENG-48 and at LBNL by the Director, Office of Energy Research, Advanced Energy Projects Division, U.S. D.O.E. under contract DE-AC03-76SF00098.

MEASUREMENTS OF AXIAL MAGNETIC FIELDS PRODUCED BY THE INTERACTION OF CIRCULARLY POLARIZED LASER LIGHT WITH PLASMA AND A MINIATURE MAGNETIC BOTTLE

Z. Henis, S. Eliezer, Y. Horovitz, Y. Paiss
Plasma Physics Department, Soreq NRC, Yavne 81800, Israel

Recently the production of an axial magnetic field by circularly polarized laser light (CPLL) is of much interest. This magnetic field has different sources. One source is related to the circular motion of single electrons in the wave which is equivalent to a magnetic dipole. The superposition of all the magnetic dipoles generates the magnetization of the plasma. The second source is related to the inhomogeneity of both the electron density and the intensity of the laser beam. Another mechanism for the axial magnetic field generation is the ponderomotive force. The scaling laws for the axial magnetic field are $B \sim I$, the inverse Faraday effect, for the first two mechanisms and $B \sim I^{0.5}$ for the third (B is the magnetic field and I is the laser irradiance).

Innovative approaches to fusion energy production may rely on the interaction between CPLL and plasma. One is the concept of hot plasma confinement in a miniature magnetic bottle induced by CPLL and the other is the concept of fast ignition. In this paper measurements of the axial magnetic field produced during the interaction of circularly polarized laser light with plasma are reported. The experiments were

performed with a circularly polarized Nd:YAG laser, with a wavelength of $1.06 \mu\text{m}$ and a pulse duration of 7 ns, in a range of irradiances from 10^9 to 10^{14} W/cm^2 . Axial magnetic fields up to 2 megagauss were measured. These results are in agreement with the ponderomotive force mechanism of the axial magnetic field generation.

Two diagnostic methods were used. At low irradiances ($10^9 - 10^{11} \text{ W/cm}^2$) the axial magnetic field induced by the circularly polarized laser was measured from the voltage signal induced by the magnetic field in an output coil. The target was a torus ring made of ferrite, with a $300 \mu\text{m}$ air gap and a $300 \mu\text{m}$ diameter hole drilled through the ferrite. The laser was irradiated into the hole on the ring and created a plasma on the other side of the air gap. Due to the high permeability of the ferrite, the magnetic field lines closed through the ring. The change in the magnetic flux in the torus ring induced a voltage signal in the output coil, which was measured by an oscilloscope. The calibration was done with a 10 ns pulse generator. The experiments showed that the voltage signals changed sign when changing the laser polarization from right handed circularly to left handed circularly polarization.

At higher irradiances the inverse Faraday effect was measured using the Faraday rotation diagnostic. The axial magnetic field was determined from the rotation of the plane of polarization of a probe laser beam. This probe beam, 5 ns, 50 mJ, $0.532 \mu\text{m}$, propagates into the plasma collinearly with the main beam, reflects from the critical surface and then is directed into an analyzer system, including two photodiodes, a $\lambda/2$ plate, a polarizer and a beam splitter. The angle of rotation of the polarization of the probe beam, after propagating through the plasma, is determined by the ratio of the signals of the two photodiodes and a calibration curve of the analyzer. The calibration of the analyzer was done by reflecting the probe beam from a perfect mirror, located at the place of the target.

A concept of hot plasma confinement in a miniature magnetic bottle relying on the magnetic field generation induced by the circularly polarized laser field is described. Extrapolation of our experiments suggests that with an CPLL of 10^{18} W/cm^2 one should get 100 megagauss magnetic fields. This plasma confinement scheme utilizes both the benefits of the two main approaches, that are currently being pursued in controlled thermonuclear fusion, inertial confinement fusion (ICF) and magnetic confinement fusion (MCF). The schematic structure of this configuration is as follows: A DT plasma is created inside a cylindrical or spherical heavy conductor (or superconductor) shell

with a hole. The plasma is irradiated by an intense circularly polarized laser beam. The CPLL creates a toroidal current in the plasma, which in turn induces an opposite current in the wall. The currents induce axial magnetic fields inside and outside the plasma, in addition to the toroidal magnetic field created, for example, by the $\nabla n \times \nabla T$ mechanism. The plasma is heated resonantly by the CPLL to several keV. The main difference between ICF and the present proposal is that the necessary compression for a spark ignition scheme in ICF is not required. In this scheme a mini spheromak is created with a value of β smaller than 1. After the laser is turned off, a process of expansion and diffusion of the magnetic field lines begins both into the walls and inside the plasma. The gain of the above scheme is calculated as a function of the laser and the plasma parameters.

References

1. S. Eliezer, Y. Paiss, H. Strauss, Phys. Lett. A **164**, 416 (1992).
2. Z.M. Sheng, J.Meyer-ter-Vehn, Phys. Rev. E **54**, 1833 (1996).
3. T. Lehner, Physica Scripta **49**, 704 (1994).
4. E. Kolka, S. Eliezer, Y. Paiss, Phys. Lett. A **180**, 132 (1993).
5. M. Tabak, J. Hammer, M.E. Glinsky, W.L. Kruer, S.C. Wilks, J. Woodworth, E.M. Campbell, M.D. Perry, R.J. Mason, Phys. Plasma **1**, 1626 (1994).
6. Y. Horovitz, S. Eliezer, A. Ludmirsky, Z. Henis, E. Moshe, R. Shpitalnik, B. Arad, Phys. Rev. Lett. **78**, 1707 (1997).

DEVELOPMENT OF PLASMA HEATING AND DIAGNOSTIC TECHNIQUES ON CDX-U FOR THE SPHERICAL TORUS

R. KAITA, W. CHOE, P. EFTHIMION, M. FINKENTHAL,^a B. LEBLANC, E. LO, R. MAJESKI, J. MENARD, T. MUNSAT, R. NAZIKIAN, M. ONO, Y. PETROV,^b T. SEKI,^c D. STUTMAN,^a and J. WRIGHT

Princeton Plasma Physics Laboratory
Princeton University
Princeton, New Jersey
United States of America

1. INTRODUCTION

A relatively compact, low field spherical torus (ST) with a moderate β limit and very good confinement is an attractive, low cost option for the study of an ignited or driven-burn D-T plasma. With an aspect ratio of 1.5, the Current Drive Experiment-Upgrade (CDX-U) facility is well-suited to investigate the physical mechanisms for transport reduction in ST's, in order to attain significant confinement improvement.

This objective is to be achieved on CDX-U by using a variety of innovative radio frequency heating and diagnostic techniques that are particularly relevant to the ST. High harmonic fast wave (HHFW) heating is being studied on CDX-U with a rotatable fast wave antenna. Electron Bernstein waves (EBW) will be explored for both electron heating and electron temperature measurements. Other innovative diagnostics that have been demonstrated on CDX-U or are being installed on the machine include a multilayer mirror ultra-soft X-ray detector array and tangential phase contrast imaging.

2. RADIO FREQUENCY HEATING

Low aspect ratio high beta plasmas are expected to have plasma dielectric constants which are much larger than those in conventional tokamaks. Under these conditions, radio frequency (RF) waves that are slightly above the ion cyclotron frequency mode convert to ion Bernstein waves at β 's of about 10%. For waves at higher harmonics of the ion cyclotron frequency (15 to $30 \times \Omega_i$), this occurs at β 's of about 50%, so the use of higher harmonic fast waves (HHFW) extends the range of plasma current drive with RF waves.[1]

The alignment of the antenna straps relative to the local magnetic field pitch is potentially critical to good coupling of the RF waves to the plasma. This is being studied with a unique, rotatable antenna on CDX-U, and preliminary heating experiments have already been performed. Furthermore, the alignment of the antenna straps to be nearly parallel to the local magnetic field pitch will permit investigations of RF ponderomotive stabilization.[2] This can be studied by observing the effects of the applied RF on the $n=1/m=2,3$ resistive MHD modes that are present in CDX-U plasmas.

In addition to HHFW heating, other RF techniques which are planned for CDX-U explore important alternatives for ST applications. Sheared flow layers can be generated, for example, through the excitation of the Alfvén resonance or the mode-converted ion Bernstein wave. They can also provide current profile control in the presence of fast ions due to neutral beam heating or other mechanisms for generating them in future ST's.

3. PLASMA DIAGNOSTICS

The low toroidal fields and core plasma densities common to the ST preclude electron temperature measurements based on standard electron cyclotron emission techniques. Theory suggests that EBW can be emitted at blackbody levels in CDX-U plasmas.[3] These waves are accessible either directly as electrostatic waves at the plasma edge or through mode conversion scenarios. The high optical thicknesses anticipated in CDX-U should then allow proof-of-principle studies of both EBW electron heating and electron temperature measurements. This diagnostic application would augment the data from the multi-point Thomson scattering (TS) system planned for CDX-U. Components from the Tokamak Fusion Test Reactor (TFTR) will be used to replace the existing single-point, multi-pass TS diagnostic with a system capable of ten spatial measurements.

To obtain the full benefit of low aspect ratio, future ST's will minimize the size of their center stack by eliminating the Ohmic transformer. This will necessitate the development of non-inductive start-up techniques like coaxial helicity injection (CHI).[4] Thus, diagnostics that are capable of plasma measurements during this phase need to be developed. A possible technique is to use poloidal and tangential multilayer mirror arrays that are planned for ultrasoft X-ray impurity imaging.[5] A prototype version, which will detect the B IV/B V emission between 50 and 60 Å, is being installed on CDX-U. Measurements with this system will complement the C V data that are already routinely obtained with photodiode detectors on CDX-U.

An understanding of confinement improvement in ST's depends on the diagnosis of plasma turbulence, and a proof-of-principle test of tangential phase contrast imaging (PCI) for this purpose was conducted on CDX-U.[6] Until now, PCI systems integrated over radial and poloidal structures due to their vertical views. This problem was eliminated, however, by the unique tangential geometry of the diagnostic on CDX-U. Image recovery and localization of spatial structures were demonstrated by the observation of a clear wavenumber cutoff in a very strong broadband signal, and large scale coherent features in the plasma core that were well-correlated with results using other diagnostic techniques. Improvements to the PCI that are under consideration include a more reliable laser and more detectors for 2-D imaging.

4. SUMMARY

Confinement improvement in the ST depends on the successful coupling of the RF power to the plasma, and an understanding of the physical basis for its effectiveness as reflected in the temperature and density profiles and/or the magnitude of the fluctuation spectrum. Since techniques such as RF induction of sheared flow layers will result in radially localized reduction of transport (i. e., transport *barriers*), detailed profile measurements are needed to observe their local effects on the gradients and/or fluctuation levels. HHFW experiments and localized fluctuation measurements have already been performed successfully in the ST plasmas of CDX-U, and improvements in its capabilities in these areas are planned.

^aJohns-Hopkins University, Maryland

^bIoffe Institute, Russia

^cNational Institute for Fusion Science, Japan

ACKNOWLEDGEMENTS

The CDX-U project wishes to thank T. Intrator and R. Fonck of the University of Wisconsin for the use of \dot{B} and triple probes for edge plasma measurements. This work was supported by USDOE Contract No. DE-AC02-76CH03073.

REFERENCES

- [1] ONO, M. *Phys. Plasmas* **2** (1995) 4075.
- [2] D'IPPOLITO, D. A. *et al.*, *Phys. Plasmas* **2** (1995) 3429.
- [3] HOSEA J., ARUNASALAM, V., and CANO, R., *Phys. Rev. Lett.* **39** (1977) 408.
- [4] NELSON, B. A. *et al.*, *Phys. Rev. Lett.* **72** (1994) 3666.
- [5] MOOS, W., ZWICKER, A. P., REGAN, S. P., and FINKENTHAL, M., *Rev. Sci. Instrum.* **61** (1990) 2733.
- [6] LO, E., NAZIKIAN, R., STUTMAN, D., CHOE, W., and KAITA, R., *Rev. Sci. Instrum.* **68** (1997) 1206.

CONCEPT OF PULSED MULTI-MIRROR FUSION REACTOR

Chebotaev, P.Z., Knyazev, B.A., Koidan, V.S., Kruglyakov, E.P., Mirnov, V.V.,
Ryutov, D.D., Vekstein, G.E.
Budker Institute of Nuclear Physics 630090, Novosibirsk, Russia

The proposed pulsed fusion reactor with dense ($n \sim 10^{17} \text{ cm}^{-3}$) high-beta plasma is based on a long ($L \sim 200 \text{ m}$, $R \sim 5 \text{ cm}$) solenoid with a strong ($B \sim 15 \text{ T}$) magnetic field. Plasma confinement along the magnetic field is provided by a large number of magnetic mirrors (multi-mirror trap). The radial equilibrium is maintained by the chamber walls (non-magnetic confinement), while the only role of the magnetic field is to suppress the plasma heat conductivity. The energy input ($W \sim 100 \text{ MJ}$) required for the breakeven is supplied by high-power relativistic electron beams.

1. Longitudinal Confinement

The basic idea of the multi-mirror trap is to make the heat and particle losses along the magnetic field a diffusion-like process, thus substantially improving the longitudinal plasma confinement [1]. Such a regime occurs when the Coulomb mean free path λ satisfies the condition

$$\ell < \lambda/k \ll L,$$

where ℓ is the length of the mirror cell, and k is the mirror ratio. The corresponding plasma expansion time can be estimated as

$$\tau_{\parallel} \sim k^2 L^2 / \ell v_{\pi}$$

This theoretical prediction had been confirmed experimentally both in Russia and the USA [2], so extrapolation to the fusion parameters seems quite reliable. Numerical investigation of the plasma expansion along the magnetic field lines in a prospective reactor shows that the breakeven condition can be achieved under the energy input of 5 MJ/cm^2 . For the initial plasma with $n \sim 3 \cdot 10^{17} \text{ cm}^{-3}$ and $T \approx 5 \text{ keV}$ such a critical reactor requires the length $L \sim 200 \text{ m}$. Further reduction in the axial losses can be achieved by adding a small amount of heavy impurities ($Z \approx 10$) as well as making the mirror ratio increasing towards the ends of the solenoid.

2. Transverse Confinement.

The traditional magnetic confinement of fusion plasma with the parameters suitable for a multi-mirror trap requires the magnetic field of a megagauss range. Therefore the non magnetic radial confinement had been suggested, for which $\beta > 1$ [3]. Its specific features affecting the heat losses are appearance of the radial flow and strong deformation of the external magnetic field. The resulting transverse confinement time relevant to reactor parameters is

$$\tau_{\perp} \sim a R^2 / \chi_{\perp} \beta^{1/4}$$

where χ_{\perp} is the temperature diffusivity across the magnetic field, and a is a numerical factor which depends on the radial density profile of the initial plasma and the magnetic flux losses into the liner. The former effect allows improvement in the radial confinement for the density distribution peaked at the center, while the latter one results in the substantial reduction in τ_{\perp} when β becomes too high. Optimization performed with the numerical code for the radial transport shows that the energy input of $3 \cdot 10^4 \text{ J/cm}^2$ is required for the breakeven.

3. Plasma heating.

The method of a dense plasma heating by high-power microsecond relativistic electron beam with the energy content of 0.2 -0.3 MJ is studied on the GOL-3-II facility, and the recent experimental results are presented in [4]. The next step is to produce a high-beta plasma and investigate its non-magnetic confinement.

REFERENCES.

- [1] R.F. Post, Phys. Rev. Lett., **18**, 232, 1967; Budker, G.I., Mirnov, V.V., Ryutov, D.D., Pis'ma Zh. Exper. Teor. Fiz., **14**, 320, 1971; Logan, B.G., Lichtenberg, A.J., Lieberman, M.A., Makhijani, A., Phys. Rev. Lett., **28**, 144, 1971.
- [2] Budker, G.I., Danilov, V.V., Kruglyakov, E.P., Ryutov, D.D., Shunko, E.V., Zh. Exper. Teor. Fiz., **65**, 562, 1973; Logan, B.G., Brown, T.G., Lieberman, M.A., Lichtenberg, A.J., Phys. Fluids, **17**, 1302, 1974.
- [3] G.I. Budker, 1968 (unpublished); Vekshtein, G.E., Mirnov, V.V., Ryutov, D.D., Chebotaev, P.Z. in "Plasma Physics and Controlled Nuclear Fusion Research", Proc. 6th Int. Conf., v.3, 535, IAEA, Vienna, 1977.
- [4] Arzhannikov, A.V., Astrelin, V.T., Burdakov, A.V., Denisenko, P.V., Koidan, V.S., Mekler, K.I., Melnikov, P.I., Postupaev, V.V., Rovenskikh, A.F., Sinitsky, S.L., this Meeting

Submitted to
IAEA Technical Committee Meeting on Innovative Approaches to Fusion Energy
(Pleasanton, CA, October 20-23, 1997)

**SELF-FORMATION AND SELF-COMPRESSION OF
A HETEROGENEOUS SPHEROMAK-LIKE MAGNETIC CONFIGURATION
IN SHORT-PULSED DISCHARGES
and
PROOF-OF-CONCEPT EXPERIMENTS ON THE MAGNETIC IMPLOSION
AND COMPRESSION OF A HETEROGENEOUS COMPACT TOROID**

A.B. Kukushkin, V.A. Rantsev-Kartinov
INF RRC "Kurchatov Institute", 123182 Moscow, Russia

ABSTRACT. A new approach to achieving the fusion ignition is formulated which is based on the concept [1] verified by the analysis [2,3] of numerous data from an earlier experimental programs carried out at the plasma focus and Z-pinch facilities in the Kurchatov Institute. The concept also gains some support from the results of ongoing experimental programs on the Pulsed Power Z-pinch. Major principles of the respective proof-of-concept experiments are formulated.

1. **INTRODUCTION.** The long-term experience of experimental research of the short-pulsed systems, including dense Z-pinchs and plasma foci, revealed an existence of phenomenological limits for imploding/compressing the plasma by the conventional configurations of the magnetic field produced in these systems (cf. e.g. [4]). On the other hand, analysis of the high-current discharge (HCD) physics suggests the possibility to achieve desirable values of plasma energy density in HCD systems by means of imploding/compressing the plasma which is trapped by a *closed* magnetic configuration. The latter is suggested, in particular, by the observations of relatively strong soft X-ray (SXR) radiation (e.g., up to few+several tens of kiloJoules for less than 1 MJ capacitance) from a long-lived -- within time scale of the MHD predictions for a longitudinally non-uniform dense Z-pinch -- neon plasma focus formation (of the lifetime of one+few hundreds of nanoseconds) in experiments at plasma focus facilities in the Kurchatov Institute. A qualitative analysis of the possibilities for a plasma focus discharge to form such a long-lived SXR radiator leads [1] to a conclusion that the plasma focus discharge can produce, under certain conditions, a closed, spheromak-like magnetic configuration (SLMC) which ensures the enhanced lifetime both of the radiating phase of the plasma focus and of the total duration of a stable plasma formation. Subsequent analysis [2] of the available database from facility [5] enabled us to (i) verify qualitatively the hypothesis [1] and (ii) formulate in more detail the main principles/attributes of the phenomenon, as well as to identify conditions necessary for the formation of an SLMC. This analysis made it also possible to (a) recognize the reasons for missing the experimental identification of an SLMC earlier and (b) identify the diagnostic scheme necessary for the verification of the phenomenon.

Despite the physics outlined therein has been identified in plasma focus experiments the merit of major conclusion goes far beyond specific type of the high current discharge (its geometry, energy store, etc.). This has been proved, e.g., by the recent analysis [3] of the earlier experiments on a linear Z-pinch gaseous discharge. Some issues of the concept also gain support from the results of ongoing experimental programs on the Pulsed Power Z-pinch. In particular, recent success of Pulsed Power Z-pinch experiments [6,7] gives additional arguments in favor of examining the physics with certain common features (in particular, the 3D two-fluid MHD of the radial implosion and compression of the plasma) at lower values of the power/energy store as this could give reasonably high values of the output energy density with relatively high efficiency of the input energy conversion. The latter could be helpful for identifying a cost-effective path to an attractive fusion power source.

2. **FORMULATION OF THE CONCEPT.** The approach formulated may be identified as a sort of the Inertial Confinement Fusion which is based on magnetic implosion and compression of a Heterogeneous Compact Toroid in a high current discharge. In this, "fusion" aspect -- along with more traditional, Plasma Radiation Sources aspect of the problem, one could identify a number of the more or less close neighbors/predecessors to the present

implosion/compression of a (gaseous) plasma focus-type load by a translationally-implosion magnetized plasma flow in the form of a gas-puff-produced compact toroid [8] (see also references therein); the MAGO [9] and MTF [10] projects, as well as the joint project MAGO/MTF [11]. The present approach differs from the above-mentioned ones in several points of physics and technology.

The key points of the concept are as follows:

(A) stimulating, at the implosion stage, the eventual self-production of a target pre-fusion plasma in the form of a

- large-scale (up to several cm, i.e. much exceeding the "hot spot" size),

- heterogeneous,

- closed, spheromak-like magnetic configuration (SLMC),

(B) further compression of this target by the pressure of the (residual) magnetic field, not incorporated into the SLMC.

Thus, the present approach is aimed at combining the advantages of Inertial Confinement Fusion (high peak values of power density) and Magnetic Confinement Fusion (enhanced stability, provided by a closedness of magnetic configuration). In particular, the power density in the central Z- θ pinch at the major axis of the SLMC exceeds, by several orders of magnitude, the peak power density achieved in the long-lasting experiments on a force-free flux-conserving spheromak (cf. [12]). The energy progression in SLMC-producing discharges includes, in particular, the self-consistent generation of a poloidal magnetic field and the strong filamentation of electric currents. Thus, the present concept differs from conventional spheromak concept not only in the general type of confinement (inertial vs. magnetic) but essentially in the plasma structuring (e.g., a heterogeneous magnetoplasma formation vs. low beta configuration) and in the higher degree of the self-organization (e.g., the self-production of a poloidal field vs. the helicity injection).

A qualitative description of the formation of the SLMC and of the energy conversion in a SLMC-producing plasma focus discharge are based on the model [1].

Major experimental results from a number of plasma focus and Z-pinch experimental facilities in Kurchatov Institute allow to summarize characteristic features of an SLMC-producing discharge. For instance, identification of the SLMC formation in plasma focus discharges appeared to be available essentially from combining the results of the following diagnostics which are complementary with respect to their spatial/spectral ranges: namely, (i) 15-ns exposure visible-light photographs of the large-scale peripheral structures; (ii) 2-ns exposure laser interferometer-made framing of the global evolution of the SLMC formation; (iii) time-integrated SXR spectra emitted by a dense plasma core. Significantly, the time-resolved SXR spectra from recent Pulsed Power Z-pinch experiments provide additional information on the complexity of plasma behavior and on the probable mechanisms of the improved stability of the implosion/compression.

3. PRINCIPLES OF PROOF-OF-CONCEPT EXPERIMENTS. The identification of the concept enabled us to formulate briefly the principles of the respective proof-of-concept experiments: namely,

(i) operational conditions necessary to stimulate SLMC formation as a target pre-fusion plasma in a high-current discharge, and

(ii) diagnostics strategy which is needed to identify formation and compression of a large-scale (up to several cm), closed magnetic configuration in high current discharges, including Pulsed Power Z-pinch experiments.

The primary conditions which have been identified which may stimulate SLMC formation in HCD systems, include the following items [2]:

(a) filamentation of the current sheath at initial stage of discharge;

(b) stimulation of the differential rotation of the (hydrodynamic) motion of the imploding plasma structure.

It follows that when optimizing the conversion of the input energy into the output ion thermal energy one should allow for the following characteristics of the plasma magnetohydrodynamics:

- 3-dimensional 2-fluid time-dependent MHD, both at implosion and compression stages;

- strong plasma inhomogeneity (filamentation etc.),

- strong short-scale mixing of the plasma and the magnetic field,

- long-range correlations of magnetic field structure and magnetic energy dissipation.

The outlined strategy can be advised for the high current discharges of various capacitance and geometries. In particular, the scale of energy store and of the input/output power may vary from moderate-voltage, non-cylindrical and cylindrical Dense Z-pinches to the recent Pulsed Power Z-pinch experiments.

REFERENCES

- [1] Kukushkin A.B., Rantsev-Kartinov V.A., "On the Possibility of Formation a Spheromak-Like Magnetic Configuration in a Plasma Focus Discharge," *Preprint of the RRC "Kurchatov Institute"*, IAE 5646/6, Moscow, June 1993.
- [2] Kukushkin A.B., Rantsev-Kartinov V.A., and Terentiev A.R., "Formation of a Spheromak-Like Magnetic Configuration by the Plasma Focus Self-Transformed Magnetic Field," *Fusion Technology*, vol. 31, No.8 (1997);; *Transactions of Fusion Technology*, vol. 27, pp.325-328 (1995); *Preprint of the RRC "Kurchatov Institute"*, IAE 5737/7, Moscow, January 1994.
- [3] Kukushkin A.B., Rantsev-Kartinov V.A., Large-Scale Stratification and Short-Scale Filamented Helical Structures in Linear Z-Pinch Gaseous Discharges. Submitted to 39th Annual Meeting of the APS Division of Plasma Physics, November 1997.
- [4] *AIP Conference Proceedings #299*, Dense Z-pinches 3rd Int. Conf., London, April 1993, Eds. M.Haines and A.Knight, AIP Press, New York (1994);
- [5] Orlov M. M., Terentiev A. R., and Khrabrov V. A., *Fizika Plazmy (Sov. J. Plasma Phys.)*, vol. 11, p.1268, p.1985; *Ibid.*, vol. 11, p.1517, 1985.
- [6] Quintenz J.P., et.al. Progress in Pulsed Power Fusion, *In: Proc. 11-th Int. Conf. High Power Particle Beams (Beams-96)*, Prague: Czech Rep. Acad. Sci., 1996, vol.1, p.1.
- [7] Sanford T.W.L., et. al. *Phys. Rev. Lett.*, 77 (1996) 5063; *Rev. Sci. Instrum.*, 68 (1997) 852; *Phys. Plasmas*, 4 (1997) 2188.
- [8] Degnan J.H., et. al., *Phys. Fluids B* 5 (1993) 2938; Kiuttu G.F., et. al., *In: Ref. [6]*, p.131.
- [9] Chernyshev V.K., *In: Ref. [6]*, v.1, p.7.
- [10] Kirkpatrick R. C., Lindemuth I. R., Ward M. S., *Fusion Technology*, vol.27, p.201, 1995.
- [11] Lindemuth I.R., et. al., *Abstracts of 4th Dense Z-Pinch Conference*, Vancouver, Canada, May 1997, paper A1o2.

US/RUSSIAN COLLABORATION: PROGRESS IN MAGNETIZED TARGET FUSION

Irvin R. Lindemuth, Carl A. Ekdahl, Robert E. Reinovsky, Los Alamos National Laboratory, and Vladimir K. Chernyshev, Vladislav N. Mokhov, All-Russian Scientific Research Institute of Experimental Physics

The first nuclear weapons design laboratories of the US (LANL) and the Russian Federation (VNIIEF) have embarked on an historical collaboration in high energy density physics and related pulsed power technology. Several joint endeavors in the collaboration represent demonstrable progress in an area of controlled fusion research known as Magnetized Target Fusion (MTF) in the US and as MAGO (Magnitnoye Obzhatiye, or "magnetic compression") in Russia. Progress has been made in both of MAGO/MTF's two requisite steps: (a) formation of a warm (e.g., 100 eV or higher), magnetized (e.g., 100 kG), wall-confined plasma within a fusion target prior to implosion; (b) subsequent quasi-adiabatic compression and heating of the plasma by (April 1994 at Sarov; October 1994 at Los Alamos; September 1995 at Sarov), Los Alamos and VNIIEF confirmed that a VNIIEF-invented plasma formation scheme appears to produce a plasma that has many, if not all, of the properties required of a pre-implosion plasma for MTF. Although not of primary interest from an MTF perspective, each experiment produced $1E13$ fusion reactions, more than ever previously achieved by Los Alamos in a controlled fusion context. In August 1996, a VNIIEF Disk Explosive Magnetic Generator (DEMG) delivered a 100-MA electrical current pulse to a imploding liner, accelerating the liner to an implosion kinetic energy of more than 20 MJ. This energy appears more than adequate for an initial MTF compression experiment, although additional experimental data and analysis are required to determine if the liner had adequate symmetry and velocity. These joint experiments are powered by explosively driven magnetic flux compression generators that offer the fusion scientist a low-cost way to do scientific experimentation which, today, cannot be performed in any other manner. For MTF in a fusion energy context, of course, magnetic flux compression generators would ultimately be replaced by a capital intensive non-explosive facility, but this investment would be made only after the MTF physics had been unquestionably demonstrated so that only engineering uncertainties remained. Existing pulsed power machines also have direct applicability to MTF. Thus, compared to the conventional approaches, MTF is unique in that the best available theoretical and computational predictions suggest that fusion ignition and substantial fuel burn-up can be accomplished without a major capital investment in a next-generation facility.

**IAEA Technical Committee Meeting on
Innovative Approaches to Fusion Energy
October 20-23, 1997
Pleasanton, California**

Diode-Pumped Solid-State Laser-Driven Inertial Fusion Energy

Christopher D. Marshall, Camille Bibeau and Stephen A. Payne
Lawrence Livermore National Laboratory*
Livermore, California 94550

During the past several years, significant progress has been made in laser-driven ICF research. This includes significant improvements in direct-drive ICF through beam smoothing, and recent activities on developing high-power, high repetition-rate lasers. Operation of new facilities such as Omega Upgrade and the National Ignition Facility will also further the understanding of ICF target physics.

Here we consider the critical issues and R&D pathway for laser-driven inertial fusion energy (LIFE). The goal of near-term research should be to establish a credible route to an electric power plant, which is predicated on the positive outcome of target-physics experiments planned for the National Ignition Facility (NIF) and other laser fusion facilities in the U.S. and abroad. We intend to have in-hand, by the time NIF ignites a target, a realistic pathway for inertial confinement fusion (ICF) to reach the energy goal.

We categorize the critical exploratory activities into four main areas:

1. Target physics and gain will be explored using laser drivers such as NIF (at LLNL), Nike (Naval Research Laboratory), Omega (University of Rochester), as well as major facilities in other countries. At this juncture, direct drive of targets seems to be more promising than indirect drive for energy applications, and is the main focus of the Rochester and NRL programs. The advantages include the possibility of enhanced gain and the reduction in target debris. The anticipated target gain of >100 for 4 MJ of laser energy is desirable in light of the laser driver efficiency of $<12\%$. Furthermore, advanced schemes such as "fast ignition," postulated to have gain of up to 1000, would offer tremendous opportunities for fusion energy if it proves to be viable.

2. The final optic element is perhaps one of the most difficult challenges that will be encountered by LIFE, since this optic is the interface between the laser and the ignited target. It must transmit light with minimal loss and distortion in one direction, while being irradiated with high energy neutrons and gamma rays from the other side. A number of design solutions have been proposed to stop the x-rays and ionic debris before they impinge on this optical element, such as the introduction of a high-Z gas into the unfocussed portion of the beam path.

3. Fusion chamber issues to be explored involve the survivability of the first wall in response to x-rays, debris, MeV neutrons, and gamma rays. Dry wall scenarios based on SiC and other materials are being considered, and tritium breeding can be accommodated, for example, with the use of flowing Li_2O granules. Molten salts or liquids remain candidates for wall protection, however they raise very difficult propagation issues for the laser beam. Sub-scale experiments using 100 J lasers can generate x-rays in small (cm-size) vessels to test for surface robustness against ablation; evaluations of helium embrittlement and radiation-hardness can be accomplished using a high intensity/energy neutron source, such as LANSCE at Los Alamos National Laboratory.

4. Laser driver options under consideration include the krypton-fluoride (KrF) gas laser and the diode-pumped solid-state laser (DPSSL). These laser systems have substantial promise for fusion; it is noteworthy that they are also prominent technologies within both the commercial and military domains, in addition to their central role in ICF studies. DPSSLs can provide an efficiency of 9-12 %, although significant challenges lie ahead with respect to perfecting beam smoothing and with the need to realize reduced costs for the laser diodes. High beam smoothness is needed to establish high convergence compression of the DT capsule from early-on in the laser pulse, while high efficiency (during the main pulse) minimizes the recirculating power to the driver in an electrical power plant. Both the KrF and DPSSL systems attest to the flexibility and functionality of lasers, and to their strong engineering potential.

We believe that the promise of ICF energy can be captured with a directed campaign, initially concentrating on the critical technology areas mentioned above. This effort will benefit from multiple laboratories and nationally-oriented coordination to solve the inter-related problems in plasma physics, lasers, materials science, radiation-hardness, and chemical engineering. A national effort in LIFE would also prepare us to be in a position to build on the achievement of fusion ignition by the NIF in the year 2005.

*This work was performed under the auspices of the U.S. Department of Energy by Lawrence Livermore National Laboratory under Contract No. W-7405-ENG-48.

FUSION APPROACH BASED ON SHEET Z-PINCHES

T. MIYAMOTO

*Atomic Energy Research Institute, Nihon University
Kanda-Surugadai, Chiyoda-ku, Tokyo, Japan*

1. INTRODUCTION

Many investigations have been carried out on a fiber z-pinch[1-3], but have not yet given a clear prospect for fusion plasma production. The reason results from that the plasma column is strongly unstable. Conventional z-pinch plasmas investigated so far are of a cylindrical geometry, which is magnetohydrodynamically unstable. Stabilizing effects (finite Larmor radius effect, viscous effect, etc.) have been expected to decrease the growth rate of MHD instabilities[4]. However, it seems to have failed to prove them until now. Recently, it was suggested that MHD instabilities in conventional cylindrical z-pinchs are removed in sheet z-pinchs[5]. In this summary, we describe briefly the sheet z-pinchs and the fusion criterions based on them.

2. SHEET Z-PINCH

First, we consider the steady state of a current-carrying plasma sheet enclosed by two yz planes spread infinitely at $x = \pm a$ (fig.1). The current flows along the z -axis. We assume that the plasma temperatures $T_i = T_e \equiv T$ and the current density i are constant in space. Then, the density and the pressure balance relation are given by $n = n_0(1 - x^2/a^2)$, $\mu_0 i^2 a^2 = 4n_0 kT$, where $n = n_0$ is the density at $x = 0$. Using the surface current density $I^* = 2ia$ and the surface density $N^* = 4n_0 a/3$ per unit width of y -direction, the pressure balance relation is rewritten as

$$\mu_0 I^{*2} = \frac{12}{a} N^* kT \quad (1)$$

If the plasma temperature is so high that the energy is lost only by Bremsstrahlung radiation, the surface current and plasma energy densities in the quasi-steady state of the sheet z-pinch are given by

$$I^* = \left(\frac{120\bar{\eta}}{\bar{P}_B} \right)^{1/2} \frac{k}{\mu_0 a} = \frac{1}{2\pi} \sqrt{\frac{5}{2}} \frac{I_{PB}}{a} \approx 8.18 \times 10^4 \frac{\sqrt{\ln \Lambda}}{a} \quad (\text{A/m}) \quad (2)$$

$$w_p^* = 3N^*kT = \frac{30\bar{\eta}k^2}{\bar{P}_B\mu_0a} = \frac{5}{6\pi} \frac{w_{PB}}{a} = 2.11 \times 10^3 \ln \Lambda \text{ (J/m}^2\text{)}, \quad (3)$$

where we introduce the Pease-Braginskii current[6] and the corresponding line plasma energy density at the steady state of cylindrical z-pinches

$$I_{PB} \equiv (8\pi k/\mu_0)\sqrt{3\bar{\eta}/\bar{P}_B} \text{ and } w_{PB} \equiv (3NkT)_{PB} = 36\pi k^2\bar{\eta}/\mu_0\bar{P}_B. \quad (4)$$

There are z-pinches with various classes of cross section with finite width. Their pressure equilibrium condition, steady current and line plasma energy density are expressed as

$$\mu_0 J^2 f_\alpha \equiv 16\pi NkT, \quad I^{(\alpha)} \equiv I_{PB}/g_\alpha, \quad w_p^{(\alpha)} \equiv w_{PB} f_\alpha/g_\alpha^2 \quad (5)$$

where f_α and g_α are the coefficients depending on a cross section α . For a fiber z-pinch, the coefficients are $f_f = g_f = 1$. For the width ℓ of the sheet z-pinch with infinite width, $f_s = 4a/3\ell$ and $g_s \doteq (2/5)^{1/2} 2\pi a/\ell$.

It is not difficult to obtain the coefficient f_α and g_α for a special sheet pinch. However, we can apply approximately f_s and g_s to the sheet z-pinch with finite width ℓ . The return current has no influence for the equilibrium of the sheet z-pinch with infinite width as well as for that of a cylindrical z-pinch. However, the return current has influence on the equilibrium of the sheet z-pinch with finite thickness.

3. FUSION CRITERIONS

Let us simplify the Lawson condition as $nt \geq [nt]_L$ and $T = T_L$. From eq.(3) the thickness is given as

$$2a = 0.207 T_L^{-1/2} (n_0/n_{solid})^{-1/2} \text{ (m)} \quad (6)$$

where $n_{solid} = 5 \times 10^{28} \text{ (m}^{-3}\text{)}$ is solid density. The condition for sustaining time is rewritten to

$$t \geq [nt]_L/n_0 = 1.87 \times 10^{-27} [nt]_L T a^2 \text{ (s)}. \quad (7)$$

We have typical conditions for $n_0 = n_{solid}$ from eqs.(6) and (7) : $2a \approx 20 \mu\text{m}$ and $t \geq 2 \text{ ns}$ for DT reaction ($T_L = 10^8 \text{ K}$ and $[nt]_{DT} = 10^{20} \text{ m}^{-3}\text{s}$), and $2a = 6.5 \mu\text{m}$ and $t \geq 200 \text{ ns}$ for DD reaction ($T_L = 10^9 \text{ K}$ and $[nt]_{DD} = 10^{22} \text{ m}^{-3}\text{s}$). When the plasma density is lower than the solid density, the sheet is thicker and the sustaining time must be longer. The main difference between the DT and DD conditions appears in their sustaining time. When the sustaining time is same in both DT and DD reactions, the density for DT reaction decreases by two orders. The condition for the sustaining time

is replaced to those on the width and length. The length is determined by energy loss along the z-axis. This criterion is the same as that in the fiber z-pinch. The width is determined by stability. The ideal sheet z-pinch with infinite width will be magneto-hydrodynamically stable, if the finite Larmor radius effect is taken into account. In the real sheet z-pinch with finite width, for example, in “barbell-like” or “hyperbolic” sheet z-pinch, it is also possible to stabilize the central region of sheet. On the other hand, the plasma is unstable at both ends as well as a fiber z-pinch. In the worst case the sustaining time will be restricted by the period that disturbances propagate from both ends to the central region, that is, by the sheet width. If the sheet is wide enough, however, the instabilities at both ends will hardly affect the plasma in the central region, because of non-linear effects. The resistive tearing mode will be rather important instead of MHD instabilities. This growth rate is $\gamma_R \approx (t_A / t_d)^{3/5} \gamma_{fiber}$, where t_d , t_A and $\gamma_{fiber} = 1/t_A$ are the magnetic diffusion time, the Alfvén transit time and the growth rate of fiber z-pinch[7], and is smaller by a few orders in interesting parameter region than γ_{fiber} .

The sheet z-pinch is considered to be equivalent to a number of $\sim \ell/a$ fiber z-pinches with radius a . Hence, the sheet z-pinch requires higher plasma and magnetic energies by $\sim \ell/a$ than a fiber z-pinch with same plasma parameters.

References

1. J.D.Sethian, A.E.Robson, K.A.Gerber, et.al., Phys.Rev.Lett. **59**, 892, 1790 (1987).
2. P.Sheehey, J.E.Hammel, I.R.Lindemuth, et.al., Phys.Fluids **B4**,3698 (1992).
3. R.Relay, D.Scudder, J.Schlachter, R.Lovberg, Phys.Plasmas **3**,1314-1323 (1996).
4. M.G.Haines and M.Coppins, Phys.Rev.Lett., **66** pp.1462-1465 (1991).
5. T.Miyamoto, To be published in Proc. of 4th Int. Conf. on Dense Z-Pinches.
6. R.S.Pease, Proc.Phys.Soc., **B70**,11(1957); S.I.Braginskii, JETP **6**, 494(1958).
7. H.P.Furth, J.Killeen and M.Rosenbluth, Phys. Fluids **6**, 459(1963).

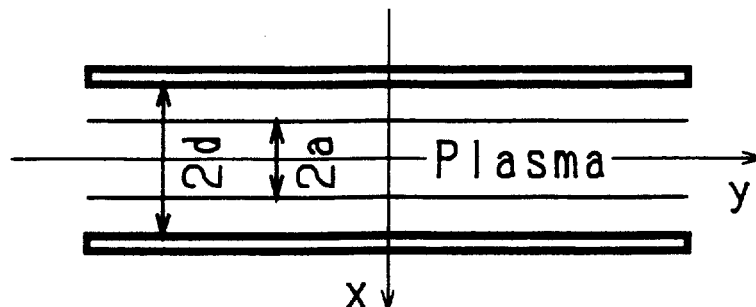

fig.1 Schematic figure of the ideal sheet z-pinch with infinite width

"Ultra-high Wall Load Fusion Concepts with Liquid Walls"

R. W. Moir, Lawrence Livermore National Laboratory

Liquids (~7 neutron mean free paths thick) with certain restrictions can probably be used in both inertial fusion¹ and magnetic fusion² designs between the burning plasma and the structural materials of the plant. The neutron wall load can be an order of magnitude higher than is the case for solid walls resulting in a high power density compact fusion power plant. Neutron wall loading of over 30 MW/m² open up fusion plasma regimes not usually encountered. In the case of inertial fusion challenging designs problems must be overcome to interface the laser or ion beam drivers with the massive amount of flowing liquid in the chamber including chamber clearing for the next microexplosion. In the case of magnetic fusion, similarly there are challenges to flowing the massive amount of liquid properly into the chamber while permitting appropriate access for heating and fueling. Evaporated liquid must be efficiently ionized in an edge plasma to prevent penetrating into the burning plasma and diminishing the burn rate. This ionized vapor would be swept along open field lines into a remote burial chamber. Promising configurations are the Field Reversed Configurations (FRC) and the Spheromak. If liquid wall protection works there are a number of profound advantages: lower the cost of electricity by more than 35%; remove the need to develop first wall materials saving over 4B\$ in development costs; reduce the amount and kind of wastes generated in the plant; permit a wider choice of materials.

References

1. R. W. MOIR, "The High-Yield Lithium-Injection Fusion-Energy (HYLIFE)-II inertial fusion energy (IFE) power plant concept and implications for IFE", *Physics of Plasmas* 2 (6) 1995)
2. R. W. Moir, "Liquid First Walls for Magnetic Fusion Energy Configurations," *Nuclear Fusion* 37 (1997) 557-566.

*Work Performed under the auspices of the U.S. Department of Energy by Lawrence Livermore National Laboratory under Contract No. W-7405-ENG-48.

A REVIEW OF SPHERICAL PINCH RESEARCH

E. Panarella*

Advanced Laser and Fusion Technology, Inc.
189 Deveault St., No. 7
Hull, P.Q., J8Z 1S7 Canada

and

Y.C. (Francis) Thio

College of Sciences, Mathematics Section
Massey University
Auckland, New Zealand 1310

The Spherical Pinch (SP)^(1,3) is a modified inertial confinement fusion (ICF) scheme incorporating a few novel features that improve, relative to the ICF, on the ability to reach breakeven or ignition. One of these novel features is a preformed hot plasma in the centre of a spherical metal container of a few centimetres in diameter, plasma which acts as a target for the strong imploding shock waves launched from the periphery of the container by means of synchronized fast electrical discharges. On collision with these imploding shock waves, the central plasma is compressed, and its density, pressure and temperature are amplified. It is found that the presence of the central plasma improves on the conditions to obtain breakeven or ignition relative to the ICF, because the time scale of the compression phenomenon is elongated, i.e., rather than being in the nanosecond regime, it is in the microsecond. Moreover, because of such elongation of the time scale, the particle density requirement for fusion is lower than in the ICF. Another favourable feature of the SP relative to the ICF is the simplicity of the experimental apparatus. In fact, rather than using sophisticated laser, ion, or electron beams to deposit energy in the peripheral shell of the container, the energy deposition is done directly by means of electrical discharges, thus improving on the efficiency of electrical energy transfer from the condenser bank to the plasma.

The historical progress on Spherical Pinch Research begins in the late 70s, when an experimental and theoretical program was carried out at the National Research Council of Canada in Ottawa on an evolution of a well-known plasma physics concept, the theta pinch, from the cylindrical geometry to the spherical. The motivation for such a study was given by the ability of the spherical configuration to overcome the serious problem of plasma end losses inherent in the cylindrical geometry. If this scheme were supplemented by the presence of a hot plasma in the centre of the spherical vessel, which could act as a target for the imploding shock waves generated in the Spherical Pinch, then these shock waves would contain and compress such central plasma, and further raise its temperature. The spherical

pinch concept would then become a device capable of seriously competing in the fusion race.

The conversion from cylindrical to spherical geometry along the lines indicated above was successful. A number of experiments were carried out and copious X-ray and neutron emission was observed from modest scale plasmas.^(1,2) This in turn led, at the beginning of the 80s, to analyze the experimental conditions required for a spherical pinch to satisfy the Lawson criteria for fusion breakeven. Following a study and modelling of the phenomenon, in 1983 the scaling laws for spherical pinch devices were derived.⁽⁴⁾ Although obtained under simplifying conditions, they nevertheless indicated that the spherical pinch concept had the potential of reaching breakeven. A series of pilot experiments designed to approach the conditions required by the scaling laws were then carried out, which verified the stability of the spherically pinched plasma under those conditions, and neutron emission, a signature of fusion reactions, was again observed.⁽⁵⁾

While this work was going on in Canada, a series of independent analytical and experimental investigations began in Italy on a configuration similar to the spherical pinch. It used a variation of this concept by exploiting the reflected shock wave from a spherical surface to increase the temperature and density of a laser plasma produced in the center of a vessel.^(6,7) In the U.S.A. another investigation was initiated on the merit comparison between spherical and toroidal geometries in their approach towards fusion breakeven conditions.⁽⁸⁾ A similar scheme was independently investigated in Los Alamos, designated by the name of Magnetized Target Fusion, where the central plasma is magnetized so that conduction losses are largely reduced.⁽⁹⁾

Encouraged by the experimental achievements, industrial interest in the Spherical Pinch began to manifest itself. In 1987 a Company (Advanced Laser and Fusion Technology, Inc. - ALFT) became operational in Canada and a particular target industrial spinoff, soft X-ray production for microlithography^(10,11), was selected as initial application of the device. This project is now in the final stage of machine prototyping.

Another industrial spinoff of the Spherical Pinch has also been seriously considered. It is neutron generation for nondestructive testing of materials. A Feasibility Study has indicated that the Spherical Pinch can become a transportable neutron generator for a neutron radiography system. An experimental proof-of-principle is now being planned, in which a 1 MJ condenser bank facility will be used for the project.⁽¹²⁾

The knowledge acquired through these industrial spinoffs on the basic operation and characteristics of the Spherical Pinch has proven fundamental in understanding the direction to follow to reach fusion ignition conditions with this machine. In particular, a numerical study carried out with realistic energy input parameters has revealed that the Spherical Pinch can become a serious contender for fusion⁽¹³⁾. The advantages of pursuing this line of research are therefore threefold: 1) the laws that govern the phenomenon are known and understood; 2) experiments aimed at proving conditions near or at ignition are, by all standards, modest scale experiments, and therefore economical; and 3) even if ignitions

conditions are not achieved in the short term, the Spherical Pinch is already providing economical returns through its industrial spinoffs.

A broad overview of the Spherical Pinch program will be provided, and future directions of research will be outlined.

References

1. E. Panarella, *Can. J. Phys.* **58**, 983 (1980).
2. Idem, *J. Fusion Energy* **6**, 285 (1987).
2. H. Chen, J. Chen, B. Hilko, and E. Panarella, *J. Fusion Energy* **13**, 45 (1994).
4. E. Panarella, and P. Savic, *J. Fusion Energy* **3**, 199 (1983).
5. E. Panarella, and V. Guty, *Proc. 1982 IEEE Intern. Conf. on Plasma Science, Ottawa, Canada, 17-19 May 1982*, p. 135.
6. F. Cornolti, F. Giammanco, and A. Giulietti, *Lett. Nuovo Cim.*, **19**, 165 (1977); A. Giulietti, M. Vaselli, and F. Giammanco, *Opt. Comm.*, **33**, 257 (1980); A. Giulietti, D. Giulietti, M. Lucchesi, and M. Vaselli, *Opt. Comm.*, **47**, 131 (1983); F. Cornolti, A. Giulietti, D. Giulietti, M. Lucchesi, and M. Vaselli, *Opt. Comm.*, **57**, 249 (1986).
7. F. Giammanco, S. Del Tredici, D. P. Singh, and M. Vaselli, *Fusion Technology* **27**, 221 (1995).
8. N. A. Salingaros, *Fusion Technology* **27**, 230 (1995).
9. R. C. Kirkpatrick, I. R. Lindemuth, and M. S. Ward, *Fusion Technology* **27**, 201 (1995).
10. P. Savic and E. Panarella, *J. Appl. Phys.* **59**, 3990 (1986).
11. K. Kawai, E. Panarella, and D. Mostacci, *SPIE Proceedings* **1465** (1991), p. 308; S. Aithal, K. Kawai, M. Lamari, and E. Panarella, *SPIE Proceedings* **1671** (1992), p. 383.
12. DND (Department of National Defence) Final Report SSC 003SV.W2207-0-AF17, 31 December 1991.
13. D. Mostacci, K. Kawai, E. Panarella, and N. Salingaros, *Bull. Amer. Phys. Soc.* **35**, 1963 (1990).

* Also with Department of Electrical Engineering, University of Tennessee, Knoxville, TN 37996-2100, U.S.A.

Magneto Inertial Confinement: A High-Gain Approach to Pulsed-Power Fusion

Paul B. Parks
General Atomics, P.O. Box 85608, San Diego, California 92186-5608

Summary

A new class of high-gain hybrid fusion concepts, combining magnetic and inertial confinement in a cylindrically symmetric configuration, is being proposed and investigated [1]. A large current is discharged through a cryogenic fiber forming a confined Z-pinch [2]. Surrounding the fiber pinch is a thin cylindrical shell of solid DT fuel which is imploded onto the pinch by a uniform distribution of x-rays emitted by a "dynamic" gold hohlraum." The hohlraum is being irradiated from the outside by x-rays from an outer array of tungsten wires carrying high currents, ~10 MA, as in the new PBFA-Z configuration. The physics of the concept is well matched to the engineering strides made in pulsed power capability, such as higher currents delivered to the load, and more uniform plasma hohlraum sources [3]. Experiments on PBFA-Z could inexpensively explore the ignition regime, and find optimal parameters. The paper accents preliminary theoretical calculations [1] and predicts nominal fiber-shell target designs in preparation for potential experiments on PBFA-Z.

Concept Description

Experiments [4] and 2-D simulations [4,5] of annular liners driven by magnetic compression are accompanied by the magnetic Rayleigh-Taylor instability and destruction of shell by nonlinear bubble-spike structures, as described by Hussey *et al.* [6] using an elegant heuristic model. The concept proposed here completely avoids magnetic compression. A magnetic central "hot spot" is formed by discharging a ~ 1 MA current through a ~ 50 μm radius, cryogenic fiber Z-pinch. Surrounding the fiber pinch is a thin ~ 600 μm shell of solid DT fuel which is imploded by x-rays emitted by a dynamic gold hohlraum irradiated by x-rays from the tungsten wire array load. Note that the return current path of the central fiber pinch is provided by a large radius outer wall which is remote from the pinch-shell-hohlraum-wire array system. Ordinary nonmagnetic Rayleigh-Taylor instabilities could be greatly minimized by using such a dynamic gold hohlraum as an x-ray driver for imploding the shell. The shell then collapses on the pinch, and by adiabatic compression the pinch is strongly heated from a few keV to fusion temperatures, > 60 keV, becoming the *primary* hot spot. During the compression, a portion of the energy stored in the surrounding magnetic field is converted to pinch energy which helps to alleviate the driver energy ($1/2 I^2 \Delta L \rightarrow p \Delta V$).

The alpha particles emitted from the primary hot spot are trapped and localized by the B_θ field and deposit their energy on the inner, one gyroradius thick, surface layer of the collapsed shell. This forms the *secondary* hot spot which triggers a thermonuclear burn wave throughout the outer layers of the imploded fuel shell. Preliminary modeling [1] indicates that ignition can occur for shell velocities ~ 10^5 cm/s, which is much lower than the 3 to 5×10^5 cm/s velocities needed in ICF. In the proposed MIC scheme, hot spot

heating is “ohmically assisted,” thereby reducing the driver requirements to only 1 TW/cm², compared to the > 100 TW/cm² believed necessary for conventional ICF. We note that the central ignitor density at peak compression is only ~ 1g/cc, and is thus quite low by ICF standards, while fusion energy gains per pulse exceed 500. Hence, the main advantage of this hybrid concept is the achievement of high fusion gain with much lower implosion velocities and driver power fluxes, ~0.1 TW per square centimeter, compared with what is believed necessary for conventional ICF.

MIC is similar to “Magnetic Target Fusion” (MTF) [7–9] in the sense that the target plasma is magnetized and preheated. The essential difference is that in MTF the target plasma is *wall-confined* by an imploding metal liner. The imbedded magnetic field in MTF merely serves to thermally insulate the target plasma from the wall during the implosion. In MIC, the target plasma is *magnetically confined*, and well separated from the imploding DT fuel shell during the implosion up until the moment of contact. The fuel formation (densification) process needed to get a high fuel burn-up fraction is they *decoupled* from the hot spot formation process. This means that a high-R fuel shell can be formed on a longer implosion time scale compared with ICF, reducing driver powers to the ~ 5 TW level easily achieved by PBFA-Z [3]. This feature is quite unlike MTF, where the fuel and hot spot are contained in the same plasma, and ICF where the dense fuel shell and the central hot spot are formed on the same (implosion) time scale. Pulsed power > 45 TW is available in the existing facilities, like PBFA-Z, to do fusion-relevant experiments near break-even conditions [3].

Fiber pinches with currents approaching the Pease-Braginskii current have remained stable over 100 Alfvén transit times if the current ramp is sufficiently rapid [2]. Fiber pinches do suffer unlimited expansion due to the $m = 0$ instability which reduces their density and precludes any possibility of achieving fusion ignition for a bare pinch. We use a phenomenological turbulent heating model of Rosenbluth [10] and Loverberg *et al.* [11] and predict that, irrespective of radiation cooling and ohmic heating, the fiber radius evolves according to

$$r(t) = \frac{C}{N^{1/2} I^{3/2}} \int_0^t I^{5/2} dt$$

where $I(t)$ is the current, N is the line density (nuclei/cm), and C is a numerical constant. Through this result, the pinch plasma density and temperature are linked, if the current waveform is specified, and thus the initial target plasma conditions at the instant of contact with the imploding DT shell can be identified. The critical shell/pinch compression phase is studied using a three-region slug model: the hot, low density adiabatic pinch region, the shocked inner shell region and the unshocked outer shell region. The shell is sufficiently cold, ~ 1 eV, and resistive, and thus moves through the magnetic field unimpeded. Assuming that the cryogenic pinch radius is initially 50 μm , and taking the pinch parameters at moment of contact ($r_p = 400 \mu\text{m}$, $T_p = 3 \text{ keV}$), the nominal shell parameters needed for ignition are as follows: Initial shell radius, $R_0 = 2.5 \text{ cm}$; initial shell thickness, $\Delta_0 = 600 \mu\text{m}$; (aspect ratio $R_0/\Delta_0 = 40$), initial velocity 1000 m/s, imploded shell radius (thickness) at moment of pinch contact, $R_f = 875 \mu\text{m}$ ($\Delta_f = 950 \mu\text{m}$). At peak compression the pinch temperature rises to nearly 70 keV which provides a sufficiently high alpha particle production rate to ignite the inner layer of the shell during the 3 ns dwell period.

Acknowledgment

Work supported by IR&D funds.

References

- [1] Parks, P.B., "Magneto-Inertial Fusion," in Physics of Alternate Magnetic Confinement Schemes, Proceedings of the Workshop Held at Varenna, Italy, Oct 15–24, 1990, edited by S. Ortolani and E. Sindoni (Societa Italiana di Fisica, Editrice Compositori, Bologna, 1991), p 1083; Parks P B ICC Workshop, Marina de Ray, March 1997, poster # 6.
- [2] Sethian, J.D. *et al.*, Phys. Rev. Lett. **59** 892 (1987).
- [3] Spielman, R.B. *et al.*, ICC Workshop, Marina de Ray, March 1997, poster # 13.
- [4] Hammer, J.H., Eddleman, J.L., Springer, P.T., *et al.*, Phys. Plasmas **3**, 2063 (1996).
- [5] Douglas, M., Deeney, C., and Roderick, N., "The Effect of Shell Thickness on Rayleigh-Taylor Mitigation in High Velocity, Annular Z-pinch Implosions," IEEE International Conference on Plasma Science, 19–12 May 1997, San Diego, California. Poster 2P59.
- [6] Hussey, T.W., Roderick, N.F., Shumlak, U., *et al.*, Phys. Plasmas **2**, 2055 (1995).
- [7] Siemon, R., ICC Workshop, Marina de Ray, March 1997, invited talk.
- [8] Lindemuth, I.R., *et al.*, Phys. Rev. Lett. **75** 1953 (1995).
- [9] Schoenberg, K.F., *et al.*, ICC Workshop, Marina de Ray, March 1997, poster # 12.
- [10] Rosenbluth, M.N., private communication, 1995.
- [11] Riley, R. and Lovberg, R., *et al.*, Phys. Plasmas **3** 1314 (1996).

Coulomb Barrier Reduction Methods for Fusion

L.J.PERKINS, S.W.HANEY, D.E. MORGAN

Lawrence Livermore National Laboratory

The size, cost and complexity of projected thermonuclear fusion reactors, magnetic or inertial, are governed by the requirement to sustain a minimum value of the temperature T of the thermalized Maxwellian plasma in the face of severe losses, including: conduction ($\sim T, \sqrt{T}$), Bremsstrahlung ($\sim T^{1/2}$), synchrotron radiation ($\sim T^{2.5}$), instabilities ($\sim T$), and disassembly ($\sim T^{1/2}$). These minimum temperatures are necessary so that energetic ions in the tail of the thermonuclear Maxwellian plasma have sufficient energy to begin to appreciably tunnel through the mutually repulsive Coulomb barrier and, therefore, induce acceptable fusion energy reaction rates. For example, in the D-T fusion reaction, the cross section rises by ~ nine orders of magnitude as the energy of the reacting ions is raised from 1keV to 10keV; this precipitous rise is entirely due to increasing barrier transmission probability.

This suggests that one approach to achieving a step-change in the physics and, perhaps, the economics of fusion power is to circumvent, at some level, this high temperature threshold set by the barrier penetration requirements of the conventional cross-section. That is, to seek methods which realize higher fusion reactivities at significantly lower temperatures. This would be particularly advantageous if we are to realize economically attractive fusion reactors based on the advanced fusion fuels.

One existing method of Coulomb barrier reduction which does work at some level is muon-catalyzed fusion. Indeed, this process optimizes at reaction temperatures of only ~ 100 's $^{\circ}\text{C}$, i.e. approximately five orders of magnitude lower than conventional thermonuclear temperatures. However, muon catalysis falls short by a factor of a few in terms of economic viability due to the finite lifetime of the muon.

We have proposed other candidate methods, including:

(a) "Shape (not spin) enhanced" fusion, which has applicability to certain advanced fuel reactions such as $p\text{-}^7\text{Li}$ and $p\text{-}^{11}\text{B}$ where the target nucleus has appreciable prolate deformation. In particular, if the incident (spherical) proton impacts on the "pointy" end of the prolate target nucleus, the effective Coulomb barrier is reduced relative to the conventional, angle-averaged value and the cross section is considerably enhanced. We predict an

approximate order-of-magnitude increase in the fusion cross section for p-¹¹B at low energy. (Note that this enhancement is considerably larger than the conventionally-studied phenomenon of "spin-polarized" fusion which affects only the nuclear term in the fusion cross section and which would realize less than a factor of two in overall cross section enhancement.)

(b) "Antiproton catalysis", where the bound (neutral) state of an antiproton and a fusion fuel nucleus can catalyze fusion in a surrounding dense fuel medium with high probability. Through this mechanism, we obtain, for the first time, a fusion cross section which *increases* with decreasing interaction energy, and predict a cross section of ~1000barns for the antiproton-catalyzed DT reaction at room temperature. The important figure-of-merit for this reaction is the number of fusions catalyzed per antiproton lost. Whereas the antiproton annihilation lifetime is dependent only on the nuclear physics of its bound, neutral couplet, the fusion reaction rate depends on the density of the surrounding fuel medium. Thus, at a sufficiently high fusion fuel density, the fusion rate should outstrip the annihilation rate and the antiproton would be free to catalyze further reactions. It appears, however, that, unless annihilation can somehow be inhibited, appreciable fusion chain lengths will only be possible in fuel densities considerably greater than those envisaged for inertial confinement fusion, i.e. considerably greater than $1. \text{e}31 \text{ m}^{-3}$.

We should continue to ask whether there are other possibilities for Coulomb barrier reduction because, of all potential methods of forcing a step change in the size and cost of devices required for the practical exploitation of fusion energy, this is where the greatest leverage may lie.

*Work performed under the auspices of the U.S. Department of Energy by Lawrence Livermore National Laboratory under Contract No. W-7405-ENG-48.

approximate order-of-magnitude increase in the fusion cross section for $p\text{-}^{11}\text{B}$ at low energy. (Note that this enhancement is considerably larger than the conventionally-studied phenomenon of "spin-polarized" fusion which affects only the nuclear term in the fusion cross section and which would realize less than a factor of two in overall cross section enhancement.)

(b) "Antiproton catalysis", where the bound (neutral) state of an antiproton and a fusion fuel nucleus can catalyze fusion in a surrounding dense fuel medium with high probability. Through this mechanism, we obtain, for the first time, a fusion cross section which *increases* with decreasing interaction energy, and predict a cross section of ~ 1000 barns for the antiproton-catalyzed DT reaction at room temperature. The important figure-of-merit for this reaction is the number of fusions catalyzed per antiproton lost. Whereas the antiproton annihilation lifetime is dependent only on the nuclear physics of its bound, neutral couplet, the fusion reaction rate depends on the density of the surrounding fuel medium. Thus, at a sufficiently high fusion fuel density, the fusion rate should outstrip the annihilation rate and the antiproton would be free to catalyze further reactions. It appears, however, that, unless annihilation can somehow be inhibited, appreciable fusion chain lengths will only be possible in fuel densities considerably greater than those envisaged for inertial confinement fusion, i.e. considerably greater than $1. \text{e}31 \text{ m}^{-3}$.

We should continue to ask whether there are other possibilities for Coulomb barrier reduction because, of all potential methods of forcing a step change in the size and cost of devices required for the practical exploitation of fusion energy, this is where the greatest leverage may lie.

*Work performed under the auspices of the U.S. Department of Energy by Lawrence Livermore National Laboratory under Contract No. W-7405-ENG-48.

Slow Liner Fusion

M.J. Schaffer
General Atomics, P.O. Box 85608, San Diego, California 92186-5608

Summary

“Slow” liner fusion (~10 ms compression time) implosions are nondestructive and make repetitive (~1 Hz) pulsed liner fusion reactors possible. This paper summarizes a General Atomics physics-based fusion reactor study [1,2] that showed slow liner feasibility, even with conservative open-line axial magnetic field confinement and Bohm radial transport.

Background

Slow liner fusion (~10 ms compression rundown time) was pioneered by A.E. Robson and colleagues as the LINUS concept [3] at the U.S. Naval Research Laboratory, where its potentially nondestructive pulses were seen as more likely to lead to a compact power reactor than “fast” liner fusion ($\ll 1$ ms rundown). In the slow liner concept, a driving system (“driver block” in the figure) implodes a thick liquid liner to compress a magnetized plasma to fusion ignition, which occurs near peak pressure during the brief liner “dwell” phase. The driver might use high pressure gas acting on pistons in various geometries. The liner, which serves as a renewable first wall and blanket, tolerates larger fusion power and neutron fluxes than conventional fusion reactors. The high neutron flux capability led the Electric Power Research Institute to sponsor the “Background Study of Liner Fusion Systems for Transmuting Fission Reactor Wastes” [1] at General Atomics. Power producing liner reactors were studied by General Atomics [2]. The physics of high- β and wall confined plasmas compressed by thick, compressible, rotating, liquid liners was studied in detail, in order to assess reactor performance.

Slow Liner Fusion Power Reactor

The conducting liner is a vortex of liquid metal rotating at a speed chosen to stabilize the Rayleigh–Taylor instability during liner deceleration and turnaround. The liquid liner is contained within a massive structure that includes, among other things, the reversible liner driver and heat removal means. The requirements of nondestructive pressures and repetitive liner driver technologies sets liner parameters: initial vortex inner radius ~1 m, compressed radius ~0.05 m, compression time ~10 ms, and fusion burn time ~100 μ s. In the simplest scaling, the energy to compress the liner and plasma grows as Q_L^2 and the

fusion energy per pulse as Q_L^3 , where $Q_L = (\text{fusion energy per pulse}) \div (\text{liner energy per pulse})$. Thus, high Q_L liner reactors are large. Typically Q_L is made < 1 , but then the compression energy must be recovered with high efficiency by a reversible driver. Since liner compressibility stores a major fraction of the liner energy, and the plasma high pressure peak duration is shorter than a sound transit time across the liner, the liner compression was studied numerically using a high pressure equation of state. High energy transfer efficiency, defined as $(\text{compressed plasma energy}) \div (\text{driving energy})$ requires high ρc^2 , low compressibility and a radially thin liner, where ρ and c are liner mass density and sound speed, respectively. Most liquids are too compressible.

The liner is made of layered immiscible liquids to combine favorable material properties. The plasma-facing layer needs high electrical conductivity, low vapor pressure and low Z, while the bulk liner must be denser and breed tritium. The inner and outer layers might be liquid Al and Pb-Li alloy, respectively. While relatively immiscible, they can be further separated by a molten halide salt layer, such as the ternary eutectic .54 LiF-.28MgF₂-.18SrF₂ (MP = 646°C), which is chemically compatible with Al, Pb and Li.

The liner containment vessel has end holes on axis, both for injection of uncompressed plasma and because solid end walls would be destroyed by the peak pressure. The liner-compatible, high- β wall-confined plasma with an open-line axial magnetic field was studied in greatest detail. Plasma and impurity transport and radiation were studied by a 1 1/2-D code [4] implementing the full Braginskii classical multispecies transport. Axial free streaming loss is reduced by inertial end tamping by dense, cold plasma. End loss is then dominated by the electron thermal conduction, $q_{e||} \sim T_e^{7/2}$, which is only important near burn temperatures. A major fraction of the end loss is dissipated in just a few cm of the plug [5], vaporizing part of the nearby liner and usefully adding end tamping mass. Radial transport is expected to be classical, based on θ -pinch experience, but Bohm transport is tolerable [4]. Since compression of magnetic flux is wasteful, operation is with $\beta > 1$ at peak compression and $\beta \gg 10$ initially (wall confinement). Cooling at the wall decreases plasma pressure there and lets plasma and magnetic flux convect radially outward until a $\beta < 1$ boundary layer is formed [6,7]. In order to avoid excessive radial plasma transport during the slow compression, the low- β boundary must be formed by injecting initial plasma on axis and allowing it to displace magnetic flux to the wall. Cold liner material vaporized by bremsstrahlung mingles with boundary layer plasma, but the classical thermal force acts radially outward and confines impurities to the boundary layer.

A reactor scoping code [1,2] was used. An example reactor is: compressed radius = 0.04 m, volume compression ratio = 400, $T = 6$ keV, $\beta = 6$, liner length = 90 m, fusion energy per pulse = 7.65 GJ, injected plasma energy = 0.235 GJ, $Q_L = 0.63$, $\eta_{net} = 0.26$ = (power for sale)÷(nuclear power). The liner was driven by He gas at 680 bar. The initial plasma might be injected by a deflagration plasma source [8], which produces a directed, high power plasma stream. Heat removal and vacuum pumping concepts are discussed in [1]. Despite the open confinement, the liner length is not much greater than the projected ITER plasma circumference of ~50 m.

Slow liner fusion reactors tolerate very conservative physics assumptions, eg. Bohm transport and open magnetic lines, but the engineering is challenging. They become more attractive if they can operate with a magnetically closed plasma, such as an FRC [1-3].

Acknowledgments

Work supported by Electric Power Research Institute, Contract No. RP 921-1, General Atomic Company and US Department of Energy Contract No. DE-AC03-89ER51114.

References

1. M.J. Schaffer *et al.*, Electric Power Research Institute Report EPRI AP-1644 (1980).
2. M.J. Schaffer *et al.*, Proc. 13th Intersociety Energy Conversion Engineering Conf., San Diego, 1978, p.1383.
3. P.J. Turchi and A.E. Robson, Proc. 6th Symp. on Engineering Problems of Fusion Research, San Diego, 1975, p. 983.
4. R.E. Waltz, Nucl. Fusion **18** (1978) 901.
5. M.J. Schaffer, Nucl. Fusion **16** (1976) 901.
6. B. Feinberg, Plasma Phys. **18** (1976) 265.
7. B. Jensen, Phys. Fluids **20** (1977) 373.
8. D.Y. Cheng and P. Wang, Nucl. Fusion **13** (1973) 458.

MAGNETIZED TARGET FUSION: PRINCIPLES AND STATUS

Richard E. Siemon, Irvin R. Lindemuth, Carl A. Ekdahl, Robert E. Reinovsky,
and Kurt Schoenberg
Los Alamos National Laboratory

Magnetized Target Fusion (MTF) is a relatively unexplored, low-cost approach to creating controlled thermonuclear fusion conditions. MTF is intermediate in time and density scales between the two more well-known controlled fusion research areas, magnetic confinement (MFE) and inertial confinement (ICF). In contrast to direct, hydrodynamic compression of initially ambient-temperature fuel (e.g., ICF), MTF involves two steps: (a) formation of a warm (e.g., 100 eV or higher), magnetized (e.g., 100 kG), wall-confined plasma within a fusion target prior to implosion; (b) subsequent quasi-adiabatic compression and heating of the plasma by imploding the confining wall, or liner. In many ways, MTF can be considered a marriage between the more mature MFE and ICF approaches, and this marriage potentially eliminates some of the hurdles encountered in the other approaches. Although the possible benefit of a magnetic field in a fusion target was recognized in the 40's by Fermi at Los Alamos and at approximately the same time by Sakharov in the former Soviet Union, it is only in light of recent advancements in plasma formation techniques, implosion system drivers, plasma diagnostics, and large-scale numerical simulation capabilities that the prospects for fusion ignition using this approach can be evaluated. MTF techniques, if current projections are realized, use drivers that, unlike large lasers and magnetic confinement systems (tokamaks), are technologically relatively simple, are modest in size and cost, and either already exist or are being developed in other contexts. Thus, compared to the conventional approaches, MTF is unique in that the best available theoretical and computational predictions suggest that fusion ignition and substantial fuel burn-up can be accomplished without a major capital investment in a next-generation facility. Because MTF can use relatively inexpensive electrical pulsed power, smaller, more economically viable reactors than for conventional fusion approaches might be possible. Because MTF is qualitatively different from inertial or magnetic confinement fusion--different time, length, and density scales--MTF reactors will have different characteristics and trade-offs, increasing the chances that a practical fusion power scheme can be found.

**Computational Modeling of Joint U.S.-Russian Experiments
Relevant to Magnetic Compression/Magnetized Target Fusion (MAGO/MTF)**

**P.T. Sheehey, R.J. Faehl, R.C. Kirkpatrick, and I.R. Lindemuth
Los Alamos National Laboratory, Los Alamos, NM 87545 USA**

Magnetized Target Fusion (MTF) experiments, in which a preheated and magnetized target plasma is hydrodynamically compressed to fusion conditions, present some challenging computational modeling problems. Recently, joint experiments relevant to MTF (Russian acronym MAGO, for Magnitnoye Obzhatiye, or magnetic compression) have been performed by Los Alamos National Laboratory and the All-Russian Scientific Research Institute of Experimental Physics (VNIIEF). Modeling of target plasmas must accurately predict plasma densities, temperatures, fields, and lifetime; dense plasma interactions with wall materials must be characterized. Modeling of magnetically driven imploding solid liners, for compression of target plasmas, must address issues such as Rayleigh-Taylor instability growth in the presence of material strength, and glide plane-liner interactions. Proposed experiments involving "liner-on-plasma" compressions to fusion conditions will require integrated target plasma and liner calculations. Detailed comparison of the modeling results with experiment will be presented.

**On Possibility of Low Dense Magnetized D-T Plasma Ignition
Threshold Achievement in MAGO System.**

**A. M. Buyko, S. F. Garanin, V. N. Mokhov,
V. B. Yakubov (presenting author)**

VNIIEF, Sarov, Nizhni Novgorod, Russia

Abstract

The MAGO concept employing the thermonuclear target with DT-gas preliminary heating up to kiloelectronvolt range temperatures which enable to reduce sufficiently requirements to the compression rate (to 10 km/s) and the compression degree (to several hundreds) of the target is investigated. The MAGO chamber with the Laval supersonic annular nozzle is used for plasma pre-heating. In this chamber magnetized plasma is accelerated up to 1000 km/s velocities and heated by collisionless shock waves. Systems with liner and magnetic compression are considered for the subsequent plasma compression. Energizing of a real size system can be supplied by the magnetic flux compression generators with energy 100-500 MJ. Experiments close to the threshold of ignition can be conducted with proportionally in 2-3 times reduced systems. Then the energy required will be 10-30 times less than in a real size system.

Basic Experiment on a Traveling Wave Direct Energy Converter for D-³He Fusion Reactor

Y. Yasaka, K. Noda, H. Momota*, and Y. Tomita*

Faculty of Engineering, Kyoto University, Kyoto 606-01, Japan

*National Institute for Fusion Science, Toki 509-52, Japan

We perform a proof-of-principle experiment of a traveling wave direct energy converter (TWDEC), which was proposed by H. Momota [1] as an efficient energy converter from high-energy protons produced by D-³He fueled fusion reactor directly into electricity. In TWDEC, the incident proton beam is velocity-modulated so as to form a bunched beam, which is to be decelerated by a traveling RF wave. The induced current in the traveling wave circuit provides RF power to the load.

As a first step of the experiment, we use low-energy He-ion beam of a few keV and investigate the interaction of the beam with RF for modulation and deceleration. An experimental setup consists of a helicon-wave ion source and two grid arrays of modulator and decelerator as shown in Fig.1. The He-ion beam of $V_{ex}=1.9$ keV is velocity-modulated with the axial RF electric field at $\omega/2\pi = 7$ MHz applied to the modulator grids with the modulation voltage V_{mod} of around 100 V. Four grids of the decelerator are aligned axially with each separation of 1.1 cm. They are connected to a transmission line which consists of series inductors and parallel capacitors terminated with a matched load resistor. We drive the transmission line at the voltage V_{dec} by the same RF source for the modulator with a variable phase difference. The energy distribution function of the beam is measured by a Faraday cup.

We have confirmed that the measured distance z from the modulator grid where the density modulation becomes a maximum is approximately given by the equation:

$$(\omega z/v_{ex})(V_{mod}/2V_{ex}) = 1,$$

in accordance with the theory [2]. Here, v_{ex} is the initial velocity of the beam.

We compare the energy distribution of the beam for $V_{dec} = 0$ and $V_{dec} = 100$ V with $V_{mod} = 100$ V. It is found from Fig.2(a) that the low energy component of the beam is increased by the application of V_{dec} . When the phase of V_{dec} with respect to V_{mod} is changed by π , the high energy component is increased as shown in Fig.2(b). These results indicate that the ion beam can be decelerated by the traveling wave as planned in the TWDEC concept.

[1] H. Momota; LA-11808, Los Alamos Natl. Lab. Rep., 8 (1989).

[2] H. Atwater; *Introduction to Microwave Theory* (McGraw-Hill, New York, 1962).

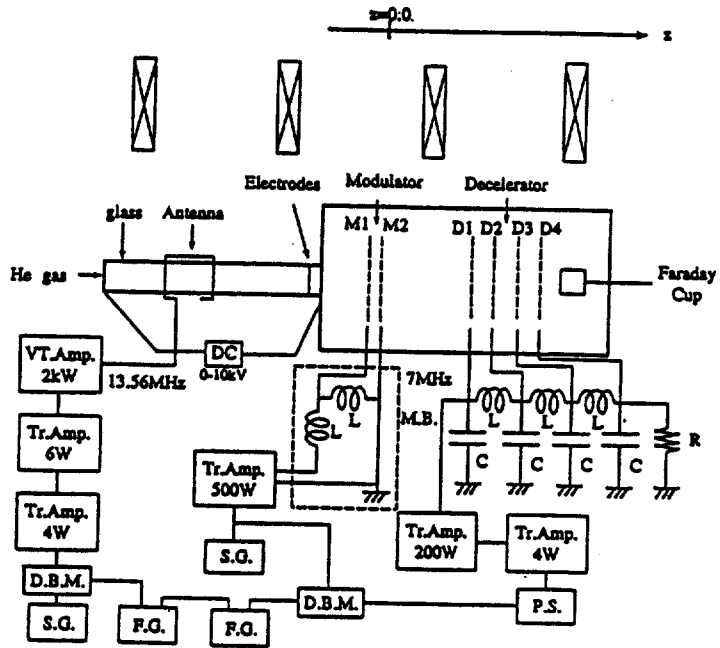

Fig. 1

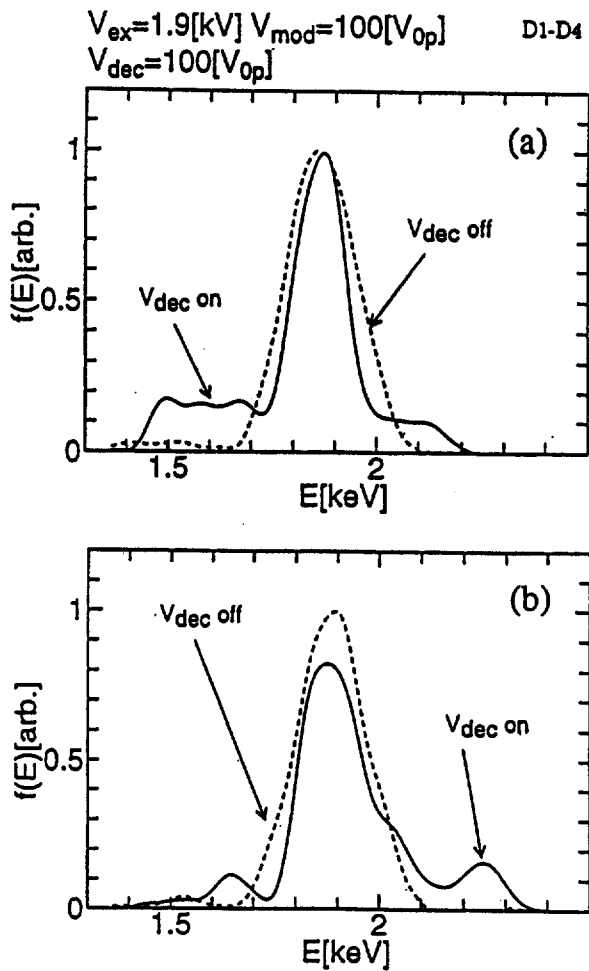

Fig. 2

DENSE PINCH DRIVEN FUSION-FISSION HYBRID REACTOR

V. Zoita and S. Lungu*

National Institute for Laser, Plasma and Radiation
Physics, P.O.B. MG36, Magurele, Bucharest, R-76911,
ROMANIA

The design concept for a 200 MW hybrid fusion-fission reactor is presented. The fission, heat-generating blanket is based on the CANDU reactor technology, while the fusion fast neutrons are provided by a high-density, pinch plasma. The reactor has a vertical cylindrical configuration, with the neutron source on the axis being surrounded by radial (fission) and axial (tritium breeding) blankets.

The basic assumption regarding the fusion neutron source is that in a pinch plasma (high-density Z-pinch and plasma focus configurations are considered) a fusion power level of 10 MW can be achieved. In a first conceptual design a repetition rate of 1 Hz is chosen for the neutron generator as an optimum value determined by technological problems raised by high energies per pulse, on one hand, and high repetition rates, on the other. The electromagnetic energy driver uses a modified Marx configuration to obtain an output pulse of 2 MV (starting from 100 kV charging voltage). The short-circuit parameters of such a driver (20 MA peak current with 800 ns rise-time) allow for a broad parameter range for the driver-load coupling.

The axial blanket is expected to produce a part of the needed tritium, the balance being supplied by the tritium produced in CANDU reactors. The radial blanket consists of 256 pressure tubes, each housing 8 standard CANDU fuel bundles. At equilibrium this blanket is fuelled with depleted uranium (0.3% U235) bundles for a discharge burnup of about 14,000 MWd/tU. The coolant (180 C, 10 bar) is light water in a natural convection flow. The pressure tubes are arranged in 3 loops in order to assure post-fission heat removal without fuel cladding failure after a loss of coolant accident.

No active components (pumps, valves, etc.) are necessary within the reactor containment area. All control is ensured by the fusion component of the reactor.

*Institute for Nuclear Reactor Engineering

**POSTER SESSION 2:
CLOSED- AND OPEN-FIELD-
LINE CONFIGURATIONS**



Spheromak Formation, Equilibrium and Merging Experiments on SSX

M. R. Brown
Swarthmore College

October 20-23, 1997

Abstract

Formation, equilibrium and merging studies have recently been performed on the Swarthmore Spheromak Experiment (SSX). Spheromaks are formed with a magnetized coaxial plasma gun and equilibrium is established in both small ($d_{small} = 0.16$ m) and large ($d_{large} = 0.50$ m) copper flux conservers. Using magnetic probe arrays we have verified that spheromak formation is governed solely by gun physics (in particular the ratio of gun current to flux, $\mu_0 I_{gun}/\Phi_{gun}$) and is independent of the flux conserver dimensions. We have also verified that equilibrium is well described by the force free condition $\nabla \times B = \lambda B$ particularly early in decay. Force-free SSX spheromaks have been partially merged to study magnetic reconnection in simple magnetofluid structures. Preliminary results indicate a characteristic scale of the reconnection layer of about 0.01 m.

Formation: SSX spheromaks are generated with a coaxial magnetized plasma gun ($r_{outer} = 0.08$ m). Before firing the gun, the inner electrode is prepared with up to 4 mCb of axial gun flux and the gap between the inner and outer electrode is filled with $\cong 1$ Coulomb of hydrogen. When up to 10 kV is applied between the inner and outer electrodes, the hydrogen is ionized and the plasma is accelerated towards the end of the gun. If the axial force on the plasma (due to I_{gun}) exceeds the magnetic tension at the end of the gun (due to Φ_{gun}) then a spheromak is formed. In figure 1 we plot the peak poloidal field measured in the spheromak as a function of $\mu_0 I_{gun}$ and Φ_{gun} for both the small (left) and large (right) flux conservers. We find a sharp

threshold for spheromak production at a value $\lambda_{th} = \mu_0 I_{gun} / \Phi_{gun} \cong 48 m^{-1}$ independent of the size of the flux conserver. The experimental value of λ_{th} is consistent with the theoretical value of $\lambda_{th} = 3.83/r_{outer}$.

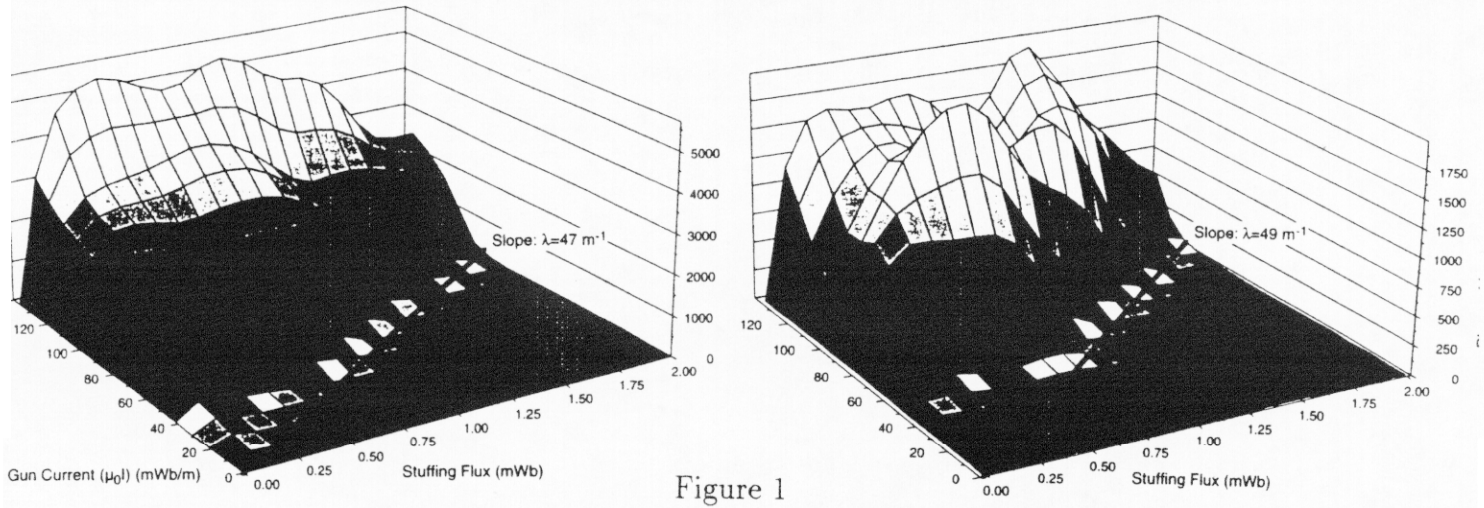

Figure 1

Equilibrium: SSX spheromaks are injected into thick walled copper flux conservers to establish equilibrium. We have found that early in the decay phase, experimental data is consistent with a force free equilibrium (governed by the expression $\nabla \times B = \lambda B$). Late in decay, departures from the force-free state are due to current profile effects (current peaking) described by $\lambda = \lambda(\psi)$. In figure 2 we plot magnetic probe data and the fit to the force-free model (using the geometrical λ as a non-adjustable parameter).

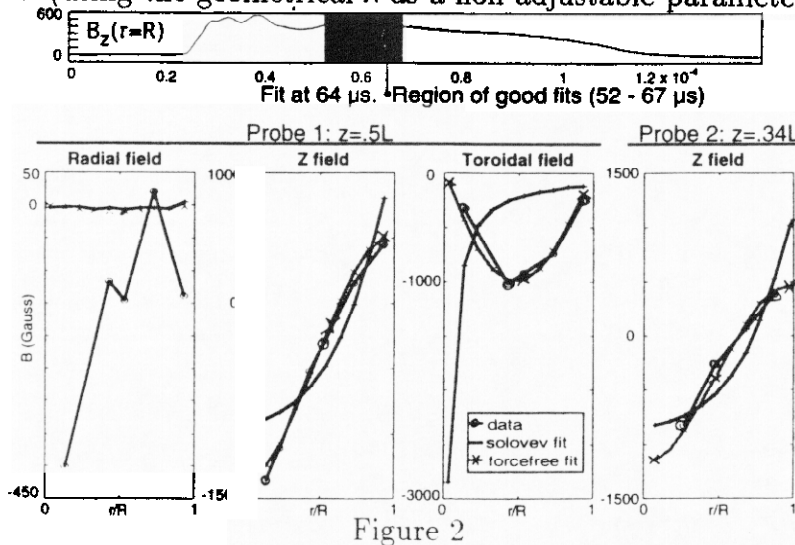

Figure 2

Merging: Spheromak merging experiments are underway at SSX. Partial merging is achieved through openings in the back walls of two identical 0.5 m diameter copper flux conservers. We observe the formation of a reconnection boundary layer at the interface of the two spheromaks using a linear probe array. The characteristic scale of the flux reversal is about 0.01 m (consistent with the diffusion scale δ_{diff} , the ion Larmor radius ρ_i and the ion inertial length c/ω_{pi}). Movies of the formation and evolution of the layer will be presented at the workshop. Plasmas are also studied using a low dispersion optical spectrograph with a CCD camera, an absolute XUV photodiode, a Faraday cup particle detector, and a velocity selector particle detector. Preliminary results indicate plasma flow out of the layer and some XUV activity correlated with formation of the reconnection layer. In figure 3 we present magnetic field data indicating a flux reversal layer formed at the interface between two spheromaks at about $t = 60 \mu s$ into the discharge (left). The probe separation is about 0.01 m. Note the enhanced magnetic activity present in the merged spheromaks compared with the relatively quiet decay of the unmerged spheromak depicted in figure 2.

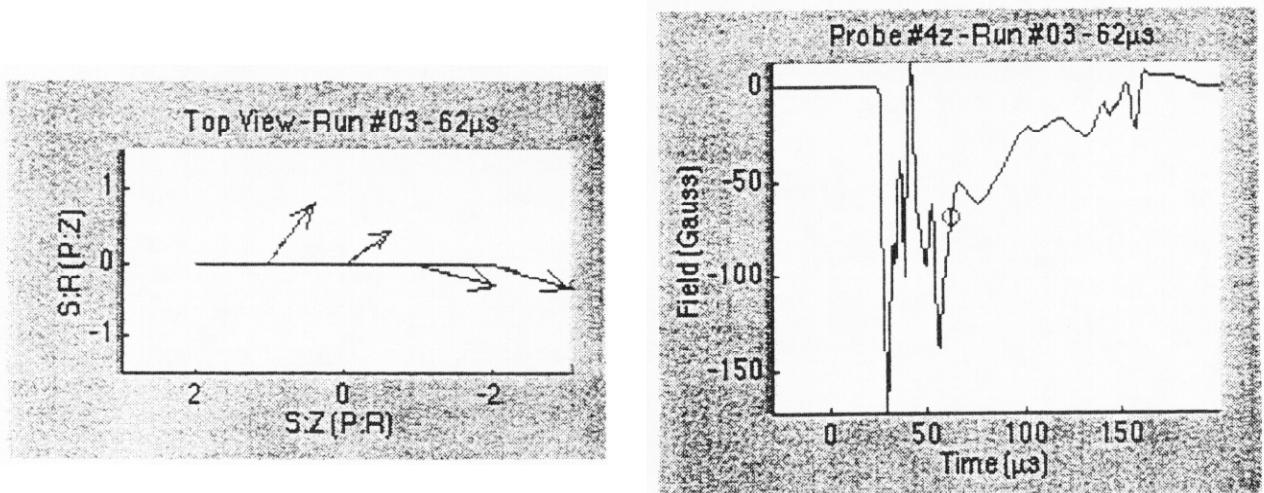

Figure 3

Elimination of plasma-material interaction problems in an advanced-fuel magnetic fusion reactor

Samuel A. Cohen

Princeton Plasma Physics Laboratory

We describe power and particle exhaust characteristics of an innovative fusion reactor configuration which avoids plasma-material interaction problems found in D-T fueled tokamaks. The innovative concept uses driven advanced fuel (e.g., D-He³ or p-¹¹B) fusion in a high-beta, field-reversed configuration (FRC) formed by the rotating magnetic field method¹ and anchored in a gas-dynamic trap (GDT). Plasma outflow on the open magnetic-field lines is cooled by radiation in the GDT, then channeled through a magnetic nozzle, promoting 3-body recombination in an expansion region. A supersonic neutral exhaust stream is predicted to occur, eliminating plasma contact with materials and providing an element essential to the stabilizing properties of the GDT. The neutral stream flows through a turbine, generating electricity. The system's linear and compact configuration, lack of radioactivity, and resolution of vexing plasma-material interaction problems, make it an attractive power plant from an engineering perspective.

1. " Review of Rotamak Research" I.R. Jones, Proc IAEA Technical Meeting on Advances in Compact Torus Research, Sidney, March 1985, IAEA-TEDOC-369 (1986) 141.

TANDEM MIRROR FUSION REACTOR CONCEPT. THE KEY PROBLEMS

G. I. Dimov

The Budker Institute of Nuclear Physics SB RAS, Novosibirsk, 1997

Extended synopsis

1. In the ambipolar trap (tandem mirror) the thermonuclear plasma can be confined in the long solenoid with quite low magnetic field of 2 T for the D-T reaction and 5 T for the D-³He reaction. The plasma outgoing along the magnetic field can be prevented by the ambipolar electric barriers on the solenoids ends. With the total axial symmetry of the ambipolar trap the neoclassic transverse loss of a plasma are eliminated and the anomalous loss can be suppressed substantially. Due to this fact one can reduce substantially the plasma radius in the reactor and reduce (proportionally to the radius) the specific neutron load on the first wall.

The diverters are located on the ends in an expanding magnetic field. In this case, there is no problem of their overload by plasma flows outgoing from the trap. The natural stationary and simple geometry facilitates much the development of the thermonuclear reactor.

It is possible that in solenoid the magnetic field is completely displaced from the plasma column by the surface diamagnetic currents in the column. Because of this, the energy loss for the cyclotron radiation of electrons is reduced substantially thereby allowing the selfsustaining D-³He thermonuclear reaction which requires high temperature of a plasma of 60 keV.

2. For the plasma longitudinal confinement, on the solenoid ends only positive electric plugs are controllably formed for the confinement of ions. The much more movable electrons are confined automatically by the positive potential of a plasma in the solenoid with respect to the end plasma receivers. By the positive charge of a plasma by the escaping electrons this potential is tuned to the value which provides the same loss for electrons and ions. The formation of plugs is made in the end mirrors joined to the solenoid. The plugs can be produced by the polarization of a plasma owing to the higher density of ions magnetized in the end mirrors. However, in the end mirrors of the D-T reactor the high magnetic field of up to 30 T and high power are required for sustaining the magnetized ions. The thermal isolation of electrons in plugs from electrons in the solenoid by the negative electric barriers (thermal barriers) enables the electron heating in a plasma to higher temperatures and due to this fact, it allows to reduce the density of magnetized ions down to the value lower than the plasma density in the solenoid.

The thermal barriers are formed by the ECR-heating of electrons on the 2nd harmonics up to the high transverse temperature (about 300 keV for the D-T reactor). Electrons in plugs are heated by ECR-field up to the temperature of 70 keV for D-T reactor with the plasma temperature in the solenoid of 20 keV. The power of the ECR-heating for electrons in the thermal barriers and plugs of the reactor turns to be quite high. However, there is a possibility in principle to reduce this power down to its acceptable value by lowering the plasma density in the thermal barriers and the plugs since the required power of the ECR-heating is proportional to the square of this density value.

3. In the thermal barriers which is a potential well the ions are trapped mainly because of the scattering of the passing ions outgoing from the solenoid. The capture of ions generated by the ionization and charge exchange of atoms penetrating a plasma from the gas can be eliminated in practice by maintaining quite high vacuum in the vicinity of thermal barriers. The pumping of the trapped ions from the thermal barriers is necessary.

The basic ions (the ions of the thermonucleus fuel) should be pumped back to the solenoid along the magnetic field. Otherwise, their longitudinal lifetime is lowered. The longitudinal pumping of ions trapped in the thermal barrier is possible by the swing of their bounce-oscillations on the parametric resonances. Such an swing is achieved by quite weak magnetic field (up to 100 G) in the thermal barrier of frequencies of up to 500 kHz. The removal of the ion admixtures and reaction products can be done by the selective transverse drift pumping out from the thermal barriers.

4. For the Maxwellian distribution of electrons in the solenoid, the electrons escaping the trap reach the end plasma receivers with a zeroth energy if the trap is short. With the flight through the long trap, the subbarrier electrons are spread over energies. In a 100 m long D-T reactor with the plasma density of $2 \cdot 10^{14} \text{ cm}^{-3}$ and its temperature of 20 keV the average energy spread of the subbarrier electrons with an energy about 12 times higher than its temperature is of the order of 1 eV for the time of the flight through the trap. The secondary emission electrons flying the solenoid with a barrier energy cannot remove the noticeable fraction of energy from a plasma. The secondary cold electrons flying through the trap replace the high temperature electrons of a plasma. As a result, their lifetime is reduced. However, the reduction of the classic energetic lifetime of a plasma in the solenoid is negligibly low even if the emission factor of the secondary electrons per one electron-ion pair is much higher than unity.

5. The transverse energy of the secondary electrons can be substantially grow for a single flying of a plug especially at a strong ECR-heating of electrons in a plug on the 1st harmonic. Such electrons can be confined in a trap by the magnetic mirrors and they can have an energy much higher than the electron barrier. As a result, in the distribution of electrons the high temperature components appear. A substantial fraction of electrons from the trap reach the plasma receivers with high energy. SEE grows sharply and the «third» etc. electron emission occurs. The number of electrons entering the trap increases. The energy consumption for the ECR-heating of electrons increases substantially. In order to weaken this effect one should:

- 1) use only the «weak» ECR-heating in plugs;
- 2) the magnetic fields in the inner throats of the end mirrors should be made noticeably lower than the field in the outer throats;
- 3) take measures to reduce SEE and increase the reflection of the secondary electrons from plasma receivers from the input into the end magnetic throats (without increase in the electron energy).

6. As the main method of MHD-stabilization for the high temperature plasma in the completely axisymmetric ambipolar trap it is suggested to use the stabilization by the conducting jacket (chamber walls) combined with the FLR effect at $\beta \sim 1$. In this case, a substantial gap between the jacket (wall) and plasma is admissible. For the lowest azimuthal MHD modes the stability reserve is proportional $\langle (\nabla_{\parallel} \beta)^2 \rangle$. In the MHD-stabilizing mirrors (anchors) the required value of a mean square gradient β is achieved by the anisotropic particles populations with high β . In the solenoid, a sufficient value is achieved by a low scale rippling.

In the high β plasma stabilized with conducting walls in the rippled solenoid the instability of the trapped particles might not develop. This fact enables one to connect the stationary MHD anchors to the trap ends in series behind the barrier end mirrors.

Since the complete (robust) stabilization of a plasma by this method takes place only at β larger than its critical value, one has to provide the macroscopic stability during the storage of a plasma. There are several methods to make it. It is not hard to stabilize the slow instability of a plasma (development time is 0.1 - 1 s) occurred due to the jacket finite conductivity.

There are possible several schemes for the reactor design where the best conditions are provided for maintaining the MHD-stability and ambipolar barriers for the longitudinal confinement of a plasma and also for providing the start up.

7. One of the most important problem is the limitation for the plasma transverse loss. The neoclassic loss can be limited by the required level of the appropriate accuracy in the manufacture and assembly of the completely axisymmetric magnetic system. The transverse transport of a plasma will be determined by diffusion in consequence of a plasma turbulence. In this case, the most dangerous for the long solenoid is the low frequency drift instability. This

instability can be suppressed at high β and by the shear of a radial electric field. The suppression of the plasma drift instability by the shear of electric field and the corresponding decrease in the transverse loss of a plasma was realized on the GAMMA-10 device. The ion transverse lifetime in the plasma core achieved the value $(3 \times 10^4 - 10^5) \tau_{\text{Bohm}}$. On the small ambipolar trap HIEI, the transverse lifetime was increased by the order of magnitude by an increase in the shear of electric field.

There are some encouraging experimental results on the electron thermal transport. From the measurements of the energetic lifetime of the bulk-electron population in the GAMMA-10 solenoid it follows that the energetic confinement time of electrons (including the transverse loss) can reach the value of $10^4 \tau_{\text{Bohm}}$.

In a high β plasma, an electromagnetic turbulence can become of an anomalous transport. Therefore, an encouraging circumstance here is an ideal isometry of the axisymmetric trap. Therefore, in the trap there is no secondary plasma currents going along the magnetic field, there could be no magnetic islands and stochasticity regions of the magnetic field lines. In the ITER reactor with the plasma radial half size of 2.8 m the transverse energetic lifetime of $10^3 \tau_{\text{Bohm}}$ is taken as satisfactory. In order to develop the ambipolar reactor with a plasma radius in the solenoid of ~ 1 m one has to achieve there the abovementioned ratio to be an order of magnitude higher.

8. The high efficiency of the longitudinal confinement of plasma ions in tandem mirrors is demonstrated experimentally. It is necessary to lower substantially the electron longitudinal loss of the ECR-heating power in plugs.

It is quite unclear whether it is possible to lower substantially the plasma density in thermal barriers and especially in plugs with respect to the density in the solenoid. The essence here mainly not in the pumping of thermobarriers but rather in the stability of the passing ions. The large decrease in plasma density in the barriers is not necessary for the good energetic longitudinal confinement of a plasma but for a decrease in the ECR-heating power in the ambipolar reactor down to the acceptable level of 5 - 10 MW/m³.

There are some communications on the fact that the so-called «warm» bismuth base superconductions cooled by the liquid helium can keep their superconductivity in the fields up to 100 T. Therefore, there is hope that in not too distant future one can manufacture the throat coils with an axial field of 25 - 30 T that allows to achieve the passing ions density in thermobarriers of few percent of the ion density in the solenoid.

The manufacture of the mirror coils with fields of up to 30 T and obtaining a stable plasma in barriers with a density by an order of magnitude lower than that on the solenoid are the main key problems whose only solution can allow the development of the ambipolar reactor of a moderate power and of the length 100 m. For a 1 km long ambipolar reactor these problems are excluded out of the key problems.

Note, that the ambipolar trap has its advantage for the development of the experimental reactor on its base. In the experimental reactor, one can confine oneself by quite short central solenoid of the order of 20 m that will reduce substantially its production cost.

Galathea-Belt Plasma Configurations - Main Principles and First Experimental Results.

A. G. Frank, S. Yu. Bogdanov, N. P. Kyrie
General Physics Institute of the Russian Academy of Sciences,
Moscow, Russia.

Galatheas are slitless magnetic confinement systems with conductors immersed into the plasma [1]. Galathea's magnetic field has to work principally as a fence (barrier), surrounding the plasma on all the sides, in a contrast with the systems where magnetic field is an environment for plasma residing. It seems possible to make plasma diamagnetism work for the confinement purposes and to suppress convective instabilities in the Galathea-type traps [2]. An important point is an existence of the regions with high beta values inside Galathea-systems, beta may be about 1 (beta is the plasma-to-magnetic-field ratio).

Beta=1 is typical for the pinch current sheets, i.e. for quasi-one-dimensional magneto-plasma configurations which may be formed in the vicinity of singular lines of 2D or 3D magnetic fields [3-5]. Current sheet formation is usually accompanied by the effective plasma compression and its heating, so plasma density, electron and ion temperatures are of the maximum values inside the sheet, providing for beta=1. A significant point is the current sheet stability relatively both MHD and resistive (of the tearing-mode type) instabilities. The formation of a current sheet inside a system of Galathea-type is the outline of the Galathea-Belt conception [6].

In principle the Galathea-Belt is a toroidal configuration with two plasma-washed conductors (mixines). Electric currents in both mixines are of the same quantity and direction, forming a magnetic configuration with figure-of-eight separatrix. A variable magnetic flux produces an azimuthal plasma electric current, resulting in the formation of a current sheet and plasma heating.

It was naturally to start experimental study of the Galathea-Belt systems using a simple cylindrical device with two straight mixines and electrode discharge [7]. Note, that heat and particles longitudinal losses may be neglected in the typical experimental conditions. Electric currents in mixines produce a quasistationary 2D magnetic field with a null-line at the vacuum chamber axis (Oz direction) and with a closed separatrix surface inside the chamber. The formation and evolution of plasma configurations were studied after the electric current excitation along the null-line. The type of plasma configuration depends on the direction of plasma electric current relatively the currents in mixines. Plasma configurations consist of two different regions: the first is the plane sheet of dense plasma between mixines, the second includes two mantles surrounding mixines and having a shape similar to the separatrix surface [7,8]. The dimension of the region, where plasma electric current is concentrated, have been obtained from magnetic measurements; it is the same as the dimension of the plasma sheet between mixines. 2D distributions of plasma emission in different spectral lines reveal the stability of plasma configurations; the electron temperature has a strong gradient in a direction perpendicular to the plasma sheet, with a maximum at the sheet midplane. The time evolution of electron temperatures under various conditions have been obtained by spectroscopic methods. The temperature increases with the increase of the both quasistationary magnetic field and plasma electric current [9].

Experimental results demonstrate the formation of plasma configuration with $\beta=1$ in the Galathea-Belt system and the stability of the configuration. At the next stage it is reasonable to raise the device parameters and to study the configuration behaviour in the both quasistationary and alternating regimes.

1. Morozov A.I. Sov. Tech. Phys. Lett. 1990. V.16 (15) P.86.
2. Morosov A.I. Sov. J. Plasma Phys. 1992. V.18 (3). P.305.
3. Syrovatskii S. I. Ann. Rev. Astron. Astrophys. 1981. V.19. P.163.
4. Frank A. G. Plasma Physics and Plasma Electronics. Nova Science Publ. Commack. N. Y. 1989. P. 131.
5. Frank A.G., Bogdanov S.Yu., Burilina V.B., Kyrie N. P. Proc. ICPP-96, Nagoya, Japan. 1996. V. 1. P. 506.
6. Morozov A.I., Frank A.G. Plasma Phys.Rep. 1994. V.20. P.879.
7. Bogdanov S. Yu., Markov V.S., Morozov A.I., Frank A.G. Tech. Phys. Lett. 1995. V.21. P.995.
8. Frank A.G., Bogdanov S.Yu., Burilina V.B. et.al. Bull. Amer. Phys. Soc. 1996, V.41. N.7. P.1614.
9. Bogdanov S.Yu., Burilina V.B., Kyrie N.P. et.al. Plasma Phys. Rep. 1997. V.23 (in press).

FUSION REACTOR CONCEPT ON THE BASIS OF GAS-DYNAMIC TRAP

A.A.IVANOV, E.P.KRUGLYAKOV, V.V.MIRNOV, D.D.RYUTOV,
V.V.KATYSHEV¹, M.V. KRIVOSHEEV¹

Budker Institute of Nuclear Physics, 630090, Novosibirsk, Russia
¹ Efremov Institute, St.Petersburg, Russia

The paper is devoted to the concept of fusion reactor which is based on a gas-dynamic trap (GDT) [1,2]. The GDT plasma confinement system consists of a long axially symmetrical mirror cell and two stabilizing cells attached from both ends. The distinctive features of the GDT are a very high mirror ratio, R , in the range of a few tens, and a relatively large length, L , exceeding an effective mean free path, λR with respect to the scattering into the loss cone. Under these conditions, the plasma confined in the central cell is almost isotropic Maxwellian, and, therefore, plasma losses out of the ends are governed by a set of gas-dynamic equations. In contrast to conventional mirrors with collisionless plasma, in the GDT, collisional plasma losses through the mirrors sustain high enough plasma density in the outboard cells, where field lines curvature is favorable for plasma magneto-hydrodynamic stability. As a result the contribution of these end cells to pressure-weighted curvature overweights negative contribution from the central cell so that the entire plasma appears to be stable against curvature-driven flute modes which are potentially the most dangerous for axisymmetric system like the GDT is.

Initially [1,2] an expander end cell has been proposed in which the magnetic field gradually decreases towards the end wall. In addition, recently a cusp was also studied as a possible alternative to the expander end cell. The plasma stability issues were addressed in the experiments at the GDT facility [3,4]. In these experiments successful stabilization of the plasma with expander and cusp end cells was demonstrated and stability boundary as well as the role of the FLR effects were studied in detail. It is worthwhile to note that due to large length of the trap the FLR effects have to stabilize all flute modes in the GDT-based fusion reactor with the only exception of rigid displacement mode which can be stabilize by application feedback stabilization.

Table 1

Parameter	Version 1	Version 2
Electron temperature	9.3 keV	4.4 keV
Ion temperature	16.5 keV	4.5 keV
System length	3.2 km	6.1 km
Injection power	4.8 GW	2.8 GW
Plasma density	$1.5 \cdot 10^{14} \text{ cm}^{-3}$	$5.5 \cdot 10^{14} \text{ cm}^{-3}$
Plasma beta	0.7	0.9
Plasma radius	31 cm	29 cm

The parametric model of the GDT reactor was considered with the assumptions that longitudinal energy losses are balanced by radial neutral beam injection and particle losses are compensated by pellet injection into the central cell. The parameters of the two versions of fusion reactor with $Q=3$ are given in Table 1. The first version corresponds to minimum reactor length under limitations imposed whereas the second one was optimized to obtain minimum injection power. The limitation imposed were the following: mirror field - 45T; vacuum mirror ratio- 30; the number of ion Larmor radii over plasma radius - 10.

Possible improvements of the reactor parameters which involves use of additional mirror cells, etc, are also considered in the paper.

REFERENCES

- [1] MIRNOV, V.V., RYUTOV, D.D., *Sov. Tech. Phys. Lett.* , 5 (1979) 279.
- [2] RYUTOV, D.D., *Plasma Phys. and Controlled Fusion* 32 (1990) 999.
- [3] IVANOV, A.A., et al., *Phys. of Plasmas* 8, 5 (1994) 1529-1536.
- [4] ANIKEEV, A.V., BAGRYANSKY, P.A., BENDER E.D., et al., in: *Proc. of 22nd EPS Conf. on Contr. Fusion and Plasma Phys.*, (Bournemouth, UK, 1995) Vol.19C, part IV, 193-196.

Steady-State Inductive Helicity Injection for Flux Conservers Spheromaks
T. R. Jarboe
Aeronautics and Astronautics Department, University of Washington
Seattle, Washington

Spheromak reactor studies based on electrostatic helicity injection show the very promising reactor potential of the spheromak. However, in these designs a large amount of power is wasted in maintaining the high current density on the open field lines at the edge. This limits the allowable open flux to 1% or less and represents a significant power loss. By connecting the edge field lines to an inductive injector the plasma temperature on these field line can be higher, lowering the power loss. Eliminating the electrodes also has other potential advantages such as lower PMI power to the wall with better impurity control. The S1 spheromak used inductive methods but these methods were not compatible with a close fitting wall, necessary for spheromak stability. This paper discusses methods for steady-state inductive helicity injection that are compatible with stabilizing flux conservers. Methods for drive along the geometric axis and around the periphery are covered.

In the large CTX flux conservers the helicity was injected along the geometric axis through a coaxial tube. Both an axially symmetric magnetized Marshall gun and an $m=1$ injector were used to inject helicity through the tube and both were electrode based sources. The $m=1$ method could easily be adapted for steady state inductive current drive by using a toroidal z-pinch to act as an $m=1$ source. It might be possible to simply rotate the toroidal z-pinch instead of driving it with transformer action.

In the small CTX flux conserver experiment (which achieved electron temperatures of 400eV) the helicity was injected around the periphery. Injection at the periphery has the advantage of allowing a "bow tie" shaped flux conserver which has a higher Mercier beta limit than the standard flux conservers. the advent of pulse width modulate power supplies using IGBTs allows time dependent control of the flux boundary conditions such that it is possible to do steady state inductive helicity injection at the periphery with fairly simple geometry.

Physics Issues and Engineering Design of MRX-CT

H. Ji, M. Yamada, H. Himura, P. Heitzenroeder, R. Woolley

PPPL, Princeton University, Princeton, New Jersey 08654, USA

1. Introduction

The MRX-CT experiment has been proposed to explore the physics of compact toroids, including FRC (field reversed configuration), spheromak, spherical torus, and low-aspect-ratio RFP (reversed field pinch). These configurations have characteristically high-beta plasmas, and they hold promise for opening the road to a cost-effective, high-performance, high-power-density reactor core [1], provided confinement is sufficiently favorable. The physics of stability and confinement, which is the main subject of the MRX-CT project [2], is largely unknown especially for the FRC and the unexplored low aspect ratio RFP.

The uniqueness and significance of the proposed MRX-CT device are: (1) the novel inductive formation scheme by merging co- and counter-helicity spheromaks; (2) utilization of ohmic transformer and/or neutral beam injection to sustain CT plasmas for a significantly longer time than the energy confinement time; (3) wide-range accessibility of the global stability and confinement characteristics of FRCs by varying the important parameter $s = R_s/\rho_i$ from 2 to 40; (4) great flexibility to address effects of aspect ratio on the RFP configuration.

2. Design Issues

The MRX-CT device is designed to meet high vacuum quality, geometrical compactiveness, and yet will have great flexibilities. Flux cores and OH solenoid are central issues in engineering design in order to generate and maintain plasma current up to 250 kA. The design and manufacturing methods proposed for the flux cores are based on experience from the S-1 device to achieve 10^{-7} Torr vacuum. The surface of each flux core is covered by a thin film (< 0.2 mm) of Inconel-625 liner, which prevents direct interaction of plasma discharges with the epoxy-based core. Each spheromak is formed in between a pair of flux cores by induction with minimum interactions with flux core surfaces. The distances between the cores are adjustable. Another important engineering issue is the OH solenoid assembly which has 0.1 Vs singly-swung flux with one turn loop voltage of 100 V and stored energy up to 1 MJ. A decoupling transformer is provided in the OH-PF circuit to prevent stray poloidal field in the plasma region. Other important considerations, such as adjustable conductive shells and NBI compatibility, will also be discussed.

3. Plasma Formation

The compact toroid plasmas in MRX-CT will be formed by merging two spheromaks with the same or opposite helicities. Each spheromak will be generated by induction using a pair of flux cores at each end of the vessel by properly programming currents inside the flux cores, a new scheme developed in MRX [3]. By pulsing currents in the flux core TF coils after a quadrupole poloidal magnetic field is established by the PF coil currents in each side of formation regime,

plasmas are created around each flux core by induction, as shown in Fig.1(a). When a current channel grows from the null point of the quadrupole field and is broken off from the flux cores [Fig.1(b)], spheromaks are formed without strong interaction with the flux core surfaces. A pair of additional poloidal coils (separation coils) located near the center of the vacuum vessel will prevent the two formation regions from interfering with each other. Then these two spheromaks, which carry identical toroidal currents with the same or the opposite toroidal field, are forced to merge along a common axis by controlled external coil currents [Fig. 11(c) and (d)]. The expected current of the merged plasma is more than 200 kA. Based on the past experimental results from MRX and TS-3 [3,4], FRC can be formed by merging of counter helicity spheromaks while a larger spheromak (or RFP and ST) can be formed as a result of co-helicity merging.

4. Study of FRC Plasmas

The most important issue of the MRX-CT research is global stability of an FRC plasma as a function of s ($= R_s/\rho_i \approx 4\bar{s}$ [5]). The theory predicts stable FRC plasmas with $\bar{s} \lesssim 2$ [5]. Preliminary results from MRX showed that FRCs are very unstable at $s > 10$ without a close-fitting conductive shell [3]. The flexibility of MRX-CT will allow FRC operation at various s ($= 2 - 40$), by changing (1) the strength of the toroidal field of each spheromak before merging, (2) the plasma density before the merging, (3) the final plasma sizes with various shells, and (4) the ion mass. In addition to parameter s , the effects of plasma elongation [6] also can be studied by installing different shells and controlling the equilibrium field with the coils.

Another important goal of FRC research in the MRX-CT is the sustainment of FRC plasmas over a much longer time (1-10 ms) than the energy confinement time by an OH transformer and/or an NBI. A preliminary experiment has been carried out in TS-3 using an OH solenoid with a small poloidal flux. The OH transformer in the MRX-CT with single-swing will have a flux of 0.1 Vsec, with a maximum one-turn loop voltage of 200 V, and a capacitor bank energy up to 1 MJ. An NBI with 2-5 megawatts can sustain the FRC plasma to longer than 10 ms, reaching a quasi steady-state operation. In addition, NBI would significantly broaden the scope of the experiment by actively controlling the plasma stability with plasma rotation [7].

5. Study of Low Aspect Ratio RFP

A growing consensus in the RFP community is that suppression of magnetic fluctuations and stochasticity will lead to significant improvement in confinement. One approach to suppress the stochasticity-induced transport [8] is to reduce the number of unstable modes and increase the distance between neighboring resonant surfaces at the lower limit of aspect ratio, as supported by preliminary results of nonlinear resistive MHD simulations [9].

The goals of RFP study in MRX-CT are to determine MHD stability and global confinement characteristics of low aspect ratio RFPs. The unique formation method to be employed in the MRX-CT by merging can generate RFPs with the lowest possible aspect ratio of 1.05, since only a small TF coil is needed in the center stack. With the OH transformer in the center stack, an aspect ratio of 1.3 can be obtained with a sustained discharge. Design of the close-fitting,

conductive shell will be carried out using MHD computer codes to identify necessary shapes of the shells to stabilize external modes (tilt/shift modes). The flexibility in MRX-CT will increase our capability of searching for an optimized shape for the shell or cage. Two additional important RFP issues can be addressed with a few megawatts of NBI: (1) suppression of resistive shell modes by plasma rotation, and (2) testing of beta limits by NBI heating.

6. Summary

With its novel inductive formation scheme, unique FRC sustainment methods, and great flexibility, the MRX-CT experiment will provide fundamental physics of internal current configurations in CT plasmas. Successful FRC and spherical RFP experiments will open a new possibility for a compact reactor core design.

7. References

- [1] Special Issue, Fusion Tech. 9 (1986).
- [2] M. Yamada and H. Ji, this conference (1997).
- [3] M. Yamada, *et al.*, IAEA 1996, Paper IAEA-CN-64/CP-19.
- [4] Y. Ono, *et al.*, IAEA 1992, Vol. 2 p.619.
- [5] D.C. Barnes *et al.*, Phys. Fluids 29, 2616(1986).
- [6] L. Steinhauer and A. Ishida, Phys. Fluids B2, 2422(1990).
- [7] R.N. Sudan, Phys. Rev. Lett. 42, 1277 (1979).
- [8] G. Fiksel, *et al.*, Phys. Rev. Lett. 72, 1028 (1994).
- [9] Y.L. Ho, *et al.*, Phys. Plasmas 2, 3407 (1995).

Fig. 1 Spheromak merging sequence in the MRX-CT. (a) Vacuum quadrupole poloidal field. (b) Two spheromaks being pinched off from flux cores. (c) Two spheromaks merging with each other. (d) Final plasma formed as a result of merging.

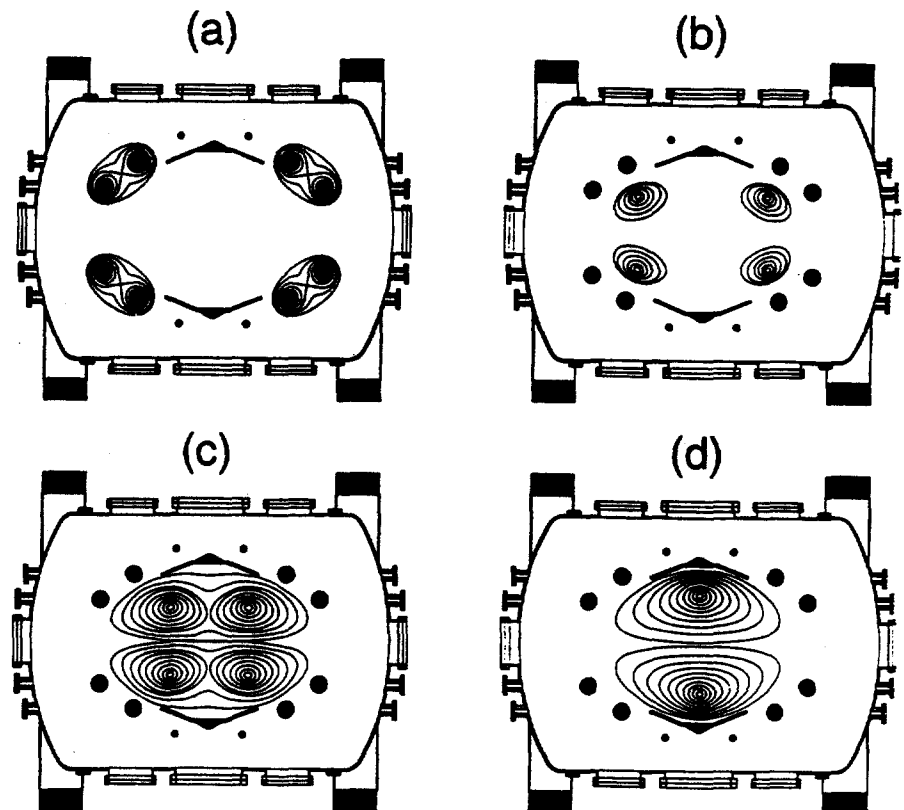

ANALYSIS OF D-3He-6Li FUEL CYCLE

*Khvesyuk V. I., **Ryzhkov S.V.

Bauman Moscow State Technical University,
Power Engineering Institute, P.O.Box 38,
107005, Moscow, Russia.

* - Professor; ** - postgraduate BMSTU

I. Introduction.

As known fusion reactors utilizing D-T fuel cycle will be compared with nuclear reactors on the radiation hazard. Consequently in the last few years are worked out physical principles of low radioactive fusion reactors utilizing D-3He mixture [1,2,3]. But serious problem of such reactors is extraction 3He from the Moon.

In this connection the analysis of 3He reception on the Earth is interesting. In this work fuel cycles that allow receipt 3He on the Earth are considered. We present the results of analysis of 3He production in p-6Li reaction and estimation of extra power heating for fusion reactor.

II. Fuel cycles

We propose and analyze of 3 different versions D-3He-6Li fuel cycles below (fig. 1.a, 1.b, 1.c):

- 2 parallel reactors: p-6Li — 3He production and D-3He — power production. Such system might provide us with 100% 3He output on the Earth.

- 1 reactor with D-3He-6Li fuel-energetic cycle, where proton (with initial energy $E_0=14.7$ MeV) - product of D-3He reaction - reacts with 6Li. This results in 3He production which is to be used here for power production in D-3He reaction. But this cycle does not guarantee industrial amount of 3He. The lack of helium-3 to be received from the Moon.

- mixed (hybrid) system of D-3He-6Li fuel, when all 3He is produced on the Earth in 2 - reactors: D-3He-6Li and p-6Li.

III. Results

In this work we consider only fusion reactors using magnetic confinement.

For all schemes mentioned above we determined the range of optimal temperatures. The power parameters, namely total fusion output, synchrotron and bremsstrahlung radiation losses are considered. In our calculations we used the following values $B=5...25$ T and $\beta=0,5...0,99$. It is shown that the most efficient operation modes of reactors for all fuels is realized at $\beta \rightarrow 1$.

Deficiency of first scheme is: high temperatures (100-200 keV) in plasma of p-6Li fusion reactor and as consequence high power expense of reception of ^3He nucleus and inefficiency of this system.

The second system has positive power output but does not provide 100% quantity ^3He on the Earth.

Therefore, we must considerate possibility of creation of hybrid system, which allows decreasing of extra power heating and increasing of total amount ^3He for power production.

IV. Conclusions.

D- ^3He - ^6Li fuel cycle allows to create low radioactive fusion reactor with next advantages:

1. ^3He reception in p- ^6Li reaction;
2. Effective using protons (product of D- ^3He reaction), that guarantee ^3He production;
3. Decrease of extra power heating and economical expenditures.

Our results show that we may obtain conditions which provide positive power output in D- ^3He - ^6Li fuel cycle. However, the further study of power balance in such plasma for exact determination of power efficiency is necessary.

References

1. Kulcinski G.L., Schmitt H.H. The Moon: an Abundant Source of Clean and Safe Fusion Fuel for the 21-st Century // UWFDM-730. 11th Intern. Scientific Forum on Fueling the 21-st Century. -Moscow (USSR), 1987.
2. Kulcinski G.L. The Case for D- ^3He Fusion Power Plants // Proc. Workshop on D- ^3He based reactor studies.- Moscow, 1991.
3. Momota H. Conceptual Design of the D- ^3He Reactor ARTEMIS, Fusion Technology, 1992. -V.21.

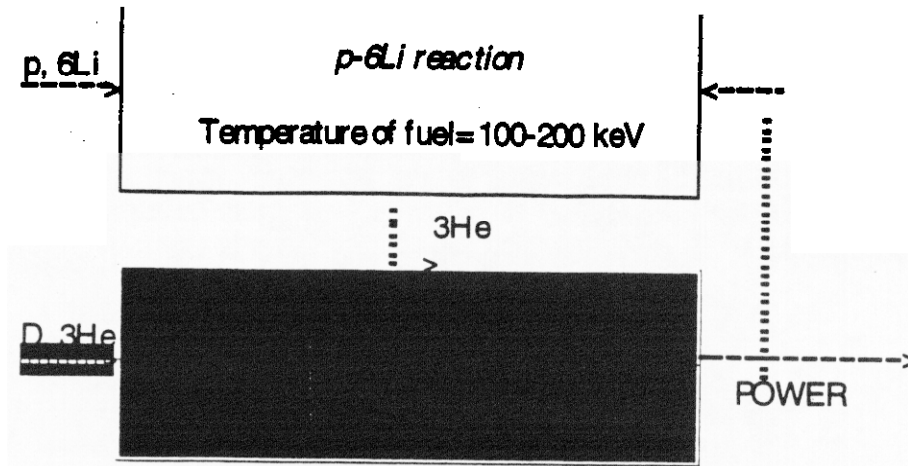

1.a. 2 stage reactor. In this system part of the power of the fusion from D-3He reactor going to support of p-6Li reaction.

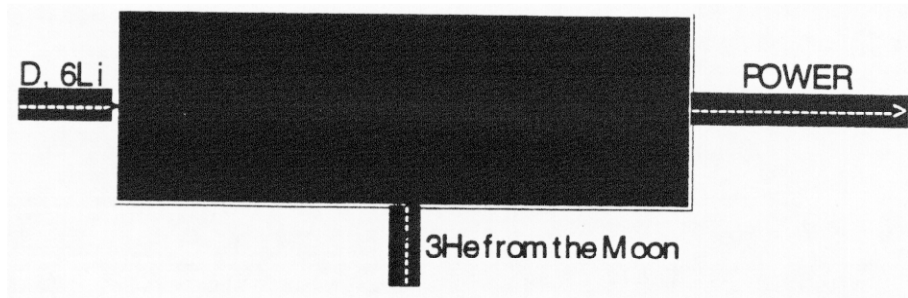

1.b. 1 reactor with D-3He-6Li mixture.

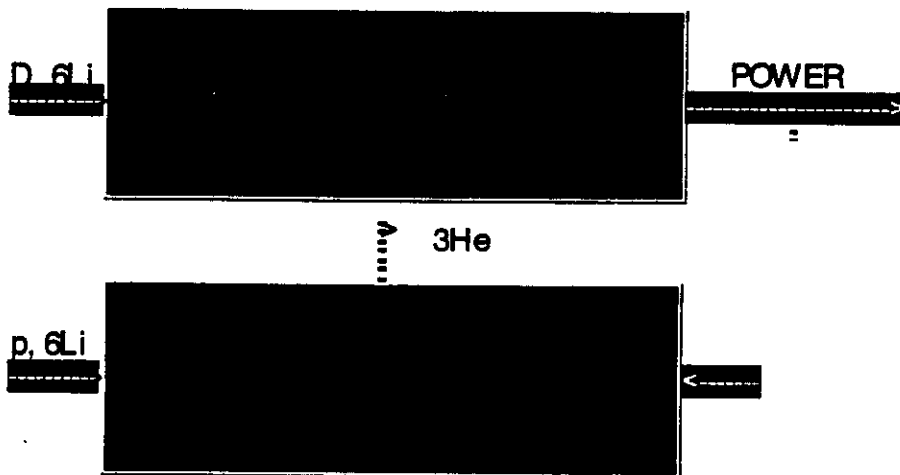

1.c. Hybrid system (combination of first and second schemes).

Fig. 1. 3 different schemes of D-3He-6Li fuel cycle.

Alfven Instabilities in FRC.

A.N.Lyakhov, V.I.Khvesyuk

*Bauman Moscow State Technical University, Power Engineering Institute
107005 Moscow, P.O.Box 38 RUSSIA*

The problem of FRC plasma stability has been studied previously, with the main attention paid to electrostatic low-hybrid instabilities [1]. But the later experiments do not allow one to consider such instabilities as a source of an anomalous transport [2]. Instead of that low frequency oscillations of magnetic field (below ion gyrofrequency) have been detected and not explained yet [2]. So it seems necessary to investigate the possibility of existence of low frequency electromagnetic instabilities in FRC.

Below we briefly discuss the drive of Alfven instability in a Field Reversed Configuration due to the nonuniformity of plasma density and magnetic field. FLR effects and high beta values are taken into account, though we have limited ourselves with slab geometry. The results show that FRC plasma is unstable. Alfven instability might be concerned as a source of anomalous transport and it seems necessary to find the techniques of suppression of this instability.

We consider the Hill's vortex configuration of magnetic field:

$$\Psi(r, z) = \frac{B_0 r^2}{2} \left[1 - \left(\frac{r}{a} \right)^2 - \left(\frac{z}{b} \right)^2 \right] \quad (1)$$

Precisely speaking we consider the slab problem, which describes well the highly elongated FRC, So r means x coordinate.

The shape of plasma density was taken as follows (here $r_0 = \frac{a}{\sqrt{2}}$):

$$\begin{cases} r < r_0 \Rightarrow p(r) = p_0 \left[1 - \frac{(r-r_0)^2}{r_0^2} \right] \\ r > r_0 \Rightarrow p(r) = p_0 \left[1 - \frac{(r-r_0)^2}{(a-r_0)^2} \right] \end{cases} \quad (2)$$

According to [3], in such plasma with $\beta \sim 1$ Alfven waves in a zero gyroradius approximation are described by the following dispersion relation:

$$Q^{(0)} = \frac{c^2}{c_A^2} (\omega^2 - \omega \Omega_i - n \omega_{ci} \Omega_i - k_z^2 c_A^2) = 0 \quad (3)$$

where $\Omega_i = \frac{\chi_b k_{\perp} T_i}{m_i \omega_{ci}}$, $\chi_b = \frac{\partial \ln B}{\partial x}$, $\omega_{ci} = \frac{eB}{m_i c}$, c_A - Alfven velocity. Next define

$$\xi_{bn} = \left(\frac{\partial \ln B}{\partial x} \right) / \left(\frac{\partial \ln n}{\partial x} \right), \text{ thus obtain}$$

$$\begin{cases} r < r_0 \Rightarrow \xi_{bn} = \frac{x}{x - r_0} \\ r > r_0 \Rightarrow \xi_{bn} = \frac{2x(a - r_0)^2}{a^2(r_0 - x)} \end{cases} \quad (4)$$

This parameter is less than 0 in all cross-section and varies from $|\xi_{bn}| \ll 1$ near separatrix to $|\xi_{bn}| \gg 1$ near the null field (where β tends to infinity). From (3) one obtains two branches of Alfvén waves:

$$\begin{aligned} \omega_1 &= \Omega_i \\ \omega_2 &= -n\omega_{ci} - \frac{k_z^2 c_A^2}{\Omega_i} \end{aligned} \quad (5)$$

Let's consider the region where $|\xi_{bn}| \gg 1$. Here we must include FLR effects. So dispersion equation is [3]:

$$Q^{(0)} + Q^{(1)} = 0 \quad (6),$$

and the growth rate is

$$\gamma = -\frac{\text{Im} Q^{(1)}}{\partial Q^{(0)} / \partial \omega} \quad (7)$$

The quantity $W = \frac{1}{\omega} \frac{\partial Q^{(0)}}{\partial \omega}$ is a dimensionless energy of oscillations. For the second root in (5) it is negative. So we conclude that the instability in the case of large negative $|\xi_{bn}| \gg 1$ is connected with the driving of Alfvén waves with negative energy.

In (7)

$$\frac{c_A^2}{c^2} \text{Im} Q^{(1)} = \frac{9}{8\sqrt{\pi}} (k_{\perp} \rho_i)^2 |k_z| v_{Ti} \frac{(1 + (n\omega_{ci})/\omega)^2}{1 + (n\omega_{ci})/2\omega} \quad (8)$$

The growth rate is to be found from (7) by replacing ω by the root from (5). Because the energy of Alfvén waves is negative, they would be driven in the case of positive dissipation, when $\omega \text{Im} Q^{(1)} > 0$. Substituting the roots (5) and limiting by the first cyclotron term ($n=1$) we obtain that in the internal zone ($r < r_0$) waves with $\omega = \omega_1$ will be unstable with the growth rate:

$$\gamma_1^Z = \frac{9}{8\sqrt{\pi}} (k_{\perp} \rho_i)^2 |k_z| v_{Ti} \frac{(1 + (\omega_{ci})/\Omega_i)^2}{(1 + (\omega_{ci})/2\Omega_i) \Omega_i} \quad (9)$$

The waves with $\omega = \omega_2$ will be unstable in the whole cross-section with the growth rate:

$$\gamma_2 = \frac{9}{8\sqrt{\pi}} (k_{\perp} \rho_i)^2 |k_z| v_{Ti} \frac{(1 - (\omega_{ci})/\omega_2)^2}{(1 - (\omega_{ci})/2\omega_2)(\Omega_i + 2\omega_{ci} + 2k_z^2 c_A^2/\Omega_i)} \quad (10)$$

It will reach its maximum at $k_z = \sqrt{|\xi_{bn}|} \frac{\omega_{ci}}{c_A}$, and will be

$$\gamma_{\max}(x) = (k_{\perp} \rho_i)^2 \sqrt{\beta} \sqrt{|\xi_{bn}|} \omega_{ci} \quad (11)$$

For the typical parameters of FRC reactor [4] and under assumption of Hill's vortex configuration of magnetic field γ grows rapidly from separatrix to the null field region, reaching the value of ω_{ci} . Near separatrix maximum γ values are of the order of $0.001\omega_{ci}$ which is still large enough to concern plasma as stable.

The results obtained are rather qualitative. The main result is that in any FRC with high beta values, due to the inhomogeneity of magnetic field and plasma density, in the region, where density and field gradients have different signs Alfvén instability will occur, even in the case of Maxwellian plasma. So it seems necessary to perform more precise fully electromagnetic analysis of such instability, with special attention paid to the definition of self-consistent level of fluctuations, as it has been previously done for mirrors [5], thus, through the comparison of calculated and experimental fluctuation spectra it will become clear - is it really the Alfvén instability and through the comparison of calculated and measured confinement times - does Alfvén instability determine the confinement times via anomalous transport?

References

1. N.Krall. Phys. Fluids, **30**, 676, (1987); Phys. Fluids, **B1**, 1811, (1989).
2. S.Okada, SW.Ueki, H.Himura, S.Goto Transactions of Fusion Technology, **27**, 341(1995).
3. Mikhailovsky A.B. Theory of plasma instabilities. Part 2. Instabilities of nonuniform plasma. M. Atomizdat, 1977 (In Russian).
4. H.Momota. Transactions of Fusion Technology.-V.27,28(1995).
5. A.N.Lyakhov, V.I.Khvesyuk Technical Physics Letters, V.22,N.20, 15(1996).

IEC Concepts for Fusion Applications

by

George H. Miley

Fusions Studies Laboratory

Univ. of Illinois Urbana-Champaign campus

103 S. Goodwin

Urbana, IL 61801

217-333-3772, fax 217-333-2906

email:g-miley@uiuc.edu

U of I researchers have developed a gridded inertial electrostatic confinement for an IEC device for use as a low-level 2.5 MeV DD-neutron source for applications such as neutron activation analysis. This device in effect operates as an ion-accelerator, plasma-target unit. Off the shelf sources of this type provide a portable long-lived neutron source with steady-state production at levels of $10^6 - 10^7$ n/s. The unique plasma physics involved in these devices which allows long-lived grids, revolves around production of ion beams (microchannels) within the plasma.

Current work is focusing on the scale-up of these devices to higher neutron yields, thus extending their applications to such areas as tomography, isotope production, luggage inspection, etc. Yet higher reaction rates could, in principle, extend the concept into a low-level power reactor. The success of the scale-up relies heavily on the physics of potential wells that are produced within the dense IEC core. Issues about this revolve around possible instabilities, rapid energetic-ion thermalization, and impurity trapping. Technological issues with the present approach include protection of the internal grids. These issues will be discussed in the presentation, along with a description of the proposed resonant ion-driven oscillation (RIDO) IEC concept.

The RIDO concept is based on synchronization of the natural ion recirculation frequency in the system with the injection of ions towards the inner core. In this way, newly generated ions converge towards the inner core at the same time that the recirculated ions arrive at their turning points. Thus, all of the recirculating ion currents are effectively superimposed towards the inner core of the device, allowing them to be accelerated from the device perimeter and converge to the center. Consequently, very large peak densities are expected to form at the ion transit frequency (around 1 MHz), providing for a high time-average fusion generation rate. An experimental setup to study RIDO using an electron-emitter assisted three-grid IEC will be described.

Heating of FRC by a Magnetic Pulse and a Proposal for Axial Magnetic Compression

S.Okada, K.Kitano, T.Kanki, K.Yamanaka, T.Otsuka, Y.Suzuki, A.Martin,
S.Yoshimura, M.Okubo, S.Sugimoto, S.Goto.

Plasma Physics Laboratory, Faculty of Engineering, Osaka University

Abstract

A plasma with field-reversed configuration (FRC) is observed to be heated and the confinement to be improved by application of a magnetic pulse. This result is explained with an approximate empirical scaling law; the particle confinement time is proportional to the square of the magnetic axis radius R divided by an ion gyro radius, and R is increased by the heating. Inspired by this result, an axial magnetic compression scheme is proposed. In this scheme, instead of compressing the plasma radially by increasing the confining magnetic field, the FRC plasma confined between a pair of mirror fields, pre-established in a metal flux conserver, is compressed axially by decreasing the distance between the mirror fields. This compression scheme provides a way to study confinement property and stability of the FRC plasma. Due to possible existence of a lower limit of the FRC length required to assure stability against the tilt mode, together with the one dimensional nature of the compression, the heating capability of this scheme is quite modest. But merit that the confinement of the FRC may be improved if the confinement scaling has a weak dependence on the plasma length and favorable dependence on the plasma radius.

Introduction

Field-reversed-configuration (FRC) plasma are produced in linear machines which have no material structures linking the plasma and, therefore, can be moved along the axis of the apparatus. The FRC plasma is produced in a quartz discharge tube surrounded by massive, high voltage pinch coils and is translocated into an adjacent confining chamber. By this technique of "translation", the theta-pinch-produced FRC plasma acquires accessibility to heating facilities. An adiabatic magnetic compression experiment was done on the translated FRC of the FRX-C / T machine in Los Alamos and remarkable heating was reported. The plasma was heated from the pressure balance temperature of 0.6 keV to 2.2keV as the confining magnetic field was increased from 0.4 T to 1.5 T in 55 micro-seconds. The energy confinement time, however, decreased by a factor of 2 to 3 to 25 micro-seconds.

At first, seeking to heat the FRC plasma without degrading confinement, we applied a magnetic pulse to the translated FRC plasma in the FRC Injection Experiment (FIX) machine. Though the increase was small, simultaneous increases in temperature and confinement time were observed. This result is shown to be consistent with an existing empirical scaling law for

Heating of FRC by a Magnetic Pulse and a Proposal for Axial Magnetic Compression

S.Okada, K.Kitano, T.Kanki, K.Yamanaka, T.Otsuka, Y.Suzuki, A.Martin,
S.Yoshimura, M.Okubo, S.Sugimoto, S.Goto.

Plasma Physics Laboratory, Faculty of Engineering, Osaka University

Abstract

A plasma with field-reversed configuration (FRC) is observed to be heated and the confinement to be improved by application of a magnetic pulse. This result is explained with an approximate empirical scaling law; the particle confinement time is proportional to the square of the magnetic axis radius R divided by an ion gyro radius, and R is increased by the heating. Inspired by this result, an axial magnetic compression scheme is proposed. In this scheme, instead of compressing the plasma radially by increasing the confining magnetic field, the FRC plasma confined between a pair of mirror fields, pre-established in a metal flux conserver, is compressed axially by decreasing the distance between the mirror fields. This compression scheme provides a way to study confinement property and stability of the FRC plasma. Due to possible existence of a lower limit of the FRC length required to assure stability against the tilt mode, together with the one dimensional nature of the compression, the heating capability of this scheme is quite modest. But merit that the confinement of the FRC may be improved if the confinement scaling has a weak dependence on the plasma length and favorable dependence on the plasma radius.

Introduction

Field-reversed-configuration (FRC) plasma are produced in linear machines which have no material structures linking the plasma and, therefore, can be moved along the axis of the apparatus. The FRC plasma is produced in a quartz discharge tube surrounded by massive, high voltage pinch coils and is translocated into an adjacent confining chamber. By this technique of "translation", the theta-pinch-produced FRC plasma acquires accessibility to heating facilities. An adiabatic magnetic compression experiment was done on the translated FRC of the FRX-C / T machine in Los Alamos and remarkable heating was reported. The plasma was heated from the pressure balance temperature of 0.6 keV to 2.2keV as the confining magnetic field was increased from 0.4 T to 1.5 T in 55 micro-seconds. The energy confinement time, however, decreased by a factor of 2 to 3 to 25 micro-seconds.

At first, seeking to heat the FRC plasma without degrading confinement, we applied a magnetic pulse to the translated FRC plasma in the FRC Injection Experiment (FIX) machine. Though the increase was small, simultaneous increases in temperature and confinement time were observed. This result is shown to be consistent with an existing empirical scaling law for

the confinement, which expresses the importance of increasing the plasma radius. Next, we propose an axial compression experiment to increase the radius of the FRC plasma and show that this method is useful for studying confinement properties and stability of the FRC plasma. A possibility properties to improve confinement is also referred.

Apparatus for Magnetic Pulse Experiment

The FRC plasma is produced by a 0.30m-diameter, 1m-long theta pinch and is launched into a 0.8m-diameter, 3m-long metal chamber (confinement region) with 0.5m long tapered regions at its both ends. The FRC plasma with a density of 5×10^{19} per cubic meter and pressure balance temperature of about 120eV is trapped in the confinement region with a bias field of 0.05T between a pair of mirror fields in the tapered regions.

The rise time of the pulsed magnetic field is chosen to be faster than the Alfvén wave speed. The coil is arranged in the metal chamber coaxially to the machine axis so as to surround the plasma and excite the compressional mode. The diameter of the coil is 66cm and it is divided into two half-turn coils, each of which is fed by separate capacitors to assure a rise time of 2.5 micro-seconds. When crowbarred at its maximum field of about 0.05 T, the pulse decays with the time constant of 50 micro-seconds.

Experimental Results and Interpretation

The shape of the separatrix and its change with time is inferred from an axial array of diamagnetic probes. To calculate the separatrix radius, the magnetic field outside the separatrix must be assumed to be constant, so the correct separatrix shape can not be obtained in this manner when there is a field from the pulse coil. Therefore, we have studied the results when the pulsed magnetic field has become sufficiently small and found that, with the application of the magnetic pulse, the volume inside the separatrix and the energy confinement time increased by about 10%. These results are interpreted as follows. As the magnetic flux is conserved inside the vacuum chamber, the fact that the volume of the plasma has increased signifies that the plasma pressure has increased and the density has decreased, implying that the temperature has increased. Assuming that the magnetic pulse is sufficiently short and using the conservation of magnetic flux inside the chamber, together with the particle number equation and the pressure balance equation just before and after the pulse, the improved confinement is shown to be consistent with the approximate empirical confinement scaling law, provided that some portion of the heating power is fed not only to ions but also to electrons.

The favorable effect of increased plasma radius on the confinement exceeds the unfavorable effect that the ion gyro radius has increased by the heating if the increase of the latter quantity is not excessive.

Axial Compression

It was shown that the confinement was improved by the heating of the FRC plasma induced by the application of a magnetic pulse, which was consistent with the empirical scaling law that the particle confinement time is proportional to the square of the plasma radius divided by the ion gyro radius. The role of the scaling law is also seen in the adiabatic compression experiment, in which the confinement time became shorter than the compression time. In this case, perhaps due to the fact that the rise time of the compression field was close to the confinement time, the degradation of the confinement was more serious than the theoretical prediction.

The axial compression scheme proposed here, will be done in such a way as to decrease the distance between the pair of mirror fields which confine the FRC plasma. With the compression, the plasma radius increases. Moreover, the external magnetic flux between the separatrix and the chamber wall is compressed and the ion gyro radius decreases. Both of these factors are favorable for the confinement if the scaling law shown so far is used. But, there are some uncertainties in applying the scaling law to the axial compression scheme. One is the unknown dependence of the law on the plasma length. The other is the possibility that the law has different expression, for example, it is written by a trapped reverse magnetic flux. For a given radial magnetic field, both of these expressions have almost the same dependence on the plasma radius and the ion gyro-radius. These two factors are not favorable for the improvement of the confinement. On the other hand if the law has a stronger dependence on the plasma radius, normalized by the conducting wall radius than the law we have been using, then the axial compression should improve confinement. When the expression given above is used with a separatrix radius of 40% of the confinement chamber radius and the plasma length is compressed to 1/2 its original length, the radius increases by 30% and the confinement time is estimated to increase by 80%.

Summary

Simultaneous heating and confinement improvement was seen by applying a magnetic pulse to the FRC plasma. The results are consistent with the existing confinement scaling law, which shows the importance of increasing plasma radius to improve confinement. To increase the radius an axial magnetic compression is proposed as a means of studying the confinement and stability of FRC plasmas.

MIXINA CONCEPT FOR THE EXPERIMENTAL GALATEYA-REACTOR

A.I. Morozov¹, V.A. Nevrovsky², V.I. Pistunovich¹

¹INF, RRC «Kurchatov Institute », Moscow, Russia

²Moscow State University of Aircraft Technology, Moscow, Russia

1. On «GALATEYAS» plasma traps.

Plasma traps with current conductors submerged into plasma were called in [1] «GALATEYAS» and for the conductors a new term «mixinas» was suggested. Mixinas are special elements of GALATEYAS. Therefore an analysis of their possible constructions is one of urgent tasks of the GALATEYA approach to plasma traps and fusion reactors.

The present paper considers some aspects of mixina design for a demonstratiive GALATEYA reactor with 1000 s long operation pulse. The mixina parameters should be chosen to retain its operating state during 1000 s in presence of DT reaction with neutron flux onto the mixina surface as high as 1 MW/m². Previously main features of the mixina construction were considered in [2] where design of mixina for stationary operation at nitrogen temperatures was suggested.

2. Concept of «radiation-accumulative» mixina.

A three shell configuration for «radiation-accumulative» mixina has been chosen. Here an external shell (we call it «red» one) attains temperature $T \sim 2000^{\circ}\text{C}$ which is sufficient for effective radiation cooling of the mixina. The red shell thickness should be enough to intercept at least 80 % of energy flux (1 MW/m²) from plasma to the mixina. An additional («gray») shell separated from the red one with a multilayer vacuum screen thermal insulation (VSTI) should reduce the energy flux to the superconductor ~ 1000 times.

Finally, the third zone («blue») is a cryozone. A superconducting system is immersed into hydrogen sludge (mixture of liquid and solid hydrogen). Here the temperature of the superconductor is stabilized at the hydrogen melting point $T = 14$ K. Temperature rise is acceptable up to 17 K by conditions of preserving superconductive state. The cryozone is also separated from the gray zone with a layer of VSTI to prevent thermal flux to the cryozone.

The task is to choose suitable materials for mentioned shells and layers and their thickness. Such goal needs a careful calculation of neutron and γ -quanta transport and absorption in a mixina construction. This work is one for the future. Here we restrict ourselves by the results of the preliminary calculations fulfilled by A.N.Svechkopal.

3. First insight.

To get the first insight into the subject we assume that the small diameter of a toroidal mixina is ~ 1.7 m. Volumetric specific heat of possible mixina materials is in the range 1.6 - 3.6 J/cm³K (being equal to 2.5; 1.64; 1.67 and 3.6 J/cm³K for W, C, Si and Fe, respectively). The estimate shows that average temperature of the mixina would reach as high value as 2000 K after 1000 s of fusion pulse if cooling is neglected. Hence radiation release of the main part (at least, $\sim 80\%$) of plasma energy, absorbed by the red shell, is necessary to restrict the mixina temperature. Let us consider each mixina zone in detail.

4. Red zone. Requirements to the red zone are: At least 80 % absorption of neutron and γ -quanta by a construction of the red zone; low pressure of material at ~ 2000 K; minimum thickness of the radiation protective material in the red zone.

We choose tungsten here, and for illustrative purposes assume that it has 10-times reduction of the energy flux associated with neutrons and γ -quanta at distance 10-15 cm and low vapour pressure (10^{-11} Torr at ~ 2000 K). Its thermal conductivity $\lambda \approx 100$ W/m K, thermal diffusivity ≈ 0.4 cm²/s. The layer mass (of 1m²) reducing the energy flux 10 times is $M_w = 1.93$ Ton/m² at the thickness 10 cm.

For the red zone considered here time scale $t = T \cdot C \rho (R^2 - R_1^2) / 2Rq_0 \approx 500$ s, and the asymptotic temperature $T = (q_0 / \epsilon \sigma)^{0.25} \approx 2200$ K at $q_0 = 10^6$ W/m² and $\epsilon \approx 0.7$ (ϵ - thermal radiation coefficient of the red zone surface which, naturally, should be made as high as possible) is virtually attained after $t = 1000$ s of heating, σ -Stefan-Boltzmann constant, ρ -specific weight, c -specific heat.

5. Blue zone (cryozone). In fact this is a coil of superconducting alloy Nb₃Sn immersed into hydrogen sludge ($T_{\text{melt}} = 14$ K, heat of melting $H_{\text{melt}} = 4.2$ J/cm³). At the cooling medium size $L = 1$ m and a superconductor small diameter 0.5 m volume of coolant is ~ 0.2 m³ and acceptable input of energy to the superconductor should be 0.8 MJ per meter run. Power flux to the superconductor must be limited (by red and gray zones and using appropriate thermal insulation between them) up to 800 W/m at operation time $t = 1000$ s.

6. Gray zone. There are some alternative materials for the gray zone: SS, C/C and SiC/SiC composites. Let us choose the shell thickness to be 40 cm plus 2 cm thick lead for absorption of γ -radiation. Estimation of the total dimension of the mixina results in the gray shell thickness about 45 cm taking into account thermal bridges.

The rate of temperature rise for the gray shell is estimated assuming that it is perfectly isolated from both sides with VSTI. This was done for two cases: a) neglecting thermal conduction ($\lambda = 0$), and b) assuming perfect thermal conduction of the gray shell material. The cryozone can be assumed to have the above mentioned dimensions (50 cm of small diameter of torus). Hydrogen sludge (with 50% content of hydrogen ice in mixture) takes up to 80 % of its volume and the construction is thermally isolated from the gray zone with the best VSTI for the present days (effective thermal conductivity $\lambda = 10^{-6}$ W/cmK [3]).

The final thickness of the shield are:
 red zone ~ 15 cm (tungsten alloy);
 gray zone ~ 45 cm;
 cryozone radius = 25 cm.

7. On thermal bridges.

Thermal bridges in the present construction are formed by load bearing elements passing through VSTI and connecting the gray zone with the red one and the cryozone. Some estimates show that thermal fluxes conducted by thermal bridges are considerably lower than energy input associated with neutron and γ quanta. Tungsten alloys for bridges attached to the red zone and stainless steel for opposite side bridges should be used from considerations on construction strength.

8. Magnetic shell around the mixina and dimensions of the superconductor.

Let us assume that a «magnetic shell» around the mixina (MSM) 50 cm thick is formed between the plasma edge and the mixina surface. It shields the mixina surface against fast α particles. If one assumes that magnetic field $B = 1$ T at the external boundary of MSM, the superconducting coil should support current $I \approx 7$ MA at chosen dimensions, and total superconductor cross-section $S \approx 630$ cm² is required. The superconductor can be made as a hollow torus with wall thickness 5 cm and minor radius 20 cm. It should have a perforated wall for easy admission of liquid hydrogen sludge to its surface.

9. Total mass of the mixina.

Calculation of mass of the mixina construction gives the total mass about 20 tons per meter run. To sustain the structure in levitating state auxiliary magnetic field about 0.03 T, generated by external magnetic coils, is required.

10. Estimating mixina cost.

The mixina cost in absolute units can not be evaluated reliably at present. However, one can make a comparative assessment just referring to the project of the ITER reactor. The mixina construction can be thought as a section having one magnetic coil of the ITER, i.e. as 1/20 part of the ITER toroidal magnetic coils or less due to its lower size. Roughly speaking, the mixina cost cannot exceed 1/20 of the magnetic system with radiation shield of the ITER.

References

1. Morozov A.I., Pis'ma Journ. Techn. Phys. 1990, Vol. 16, 1 15, p. 86.
2. Morozov A.I., Khripunov V.I., Fizika plazmy, 1992, Vol. 18, 1 7, p. 838,
3. Kurskaya T.A., Getmanets V.F., Grigorenko B.V., Inzhenerno-fizichesky zhurnal, 1988, vol. 54, 13, pp. 446-450.

Helical-D Pinch

M.J. Schaffer

General Atomics, P.O. Box 85608, San Diego, California 92186-5608

Summary

A stabilized pinch configuration is described, consisting of a D-shaped plasma cross section wrapped tightly around a guiding axis. The "helical-D" geometry produces a very large *axial* (toroidal) transform of magnetic line direction that reverses the pitch of the magnetic lines without the need of azimuthal (poloidal) plasma current. Thus, there is no need of a "dynamo" process and its associated fluctuations. The resulting configuration has the high magnetic shear and pitch reversal of the reversed field pinch (RFP). (Pitch = $P = qR$, where R = major radius.) A helical-D pinch might demonstrate good confinement at $q \ll 1$.

Background

The conventional RFP requires large azimuthal currents, which are sustained by dynamo activity, in order to reverse the axial magnetic field near the edge from that of the magnetic axis [1]. Observations from many RFP experiments and 3-dimensional resistive MHD numerical calculations show the dynamo to be closely associated with stochastic magnetic lines [1]. The relatively short open magnetic lines limit confinement. Conversely, longer magnetic lines would yield higher confinement. Indeed, when the MST RFP was operated so as to transiently induce an azimuthal electric field that partially drove the azimuthal current, the fluctuation level decreased and confinement increased [2]. As a consequence, serious consideration is now being given to driving azimuthal current by rf waves or other means in order to reduce RFP fluctuations. Direct pitch reversal by axial magnetic transform produced by external multipole helical windings was proposed by Ohkawa [3] and embodied in the OHTE experiment. The hypothesis is that a large externally imposed magnetic shear will stabilize the now superfluous "dynamo modes," reduce fluctuations and improve confinement. The new helical-D geometry [4] produces a much larger axial transform than helical windings, whose transform is very small, and might be a better test of Ohkawa's idea.

The Helical-D Pinch

We illustrate helical-D translational transform by an example consisting of a helical wire carrying current inside of a superconducting helical tube of "D"-shaped cross section,

Fig. 1(a). The magnetic field \mathbf{B} of the wire is fully contained within the tube. For simplicity, let the curved surface of the D be circular with radius r_0 centered on axis z of a cylindrical coordinate system. Since the wire path has an azimuthal component, its magnetic field has an axial component. Such a magnetic line at the circular surface is shown as segment 2-3 in Fig. 1(b). Magnetic lines at the straight surface of the D are straight lines, like segment 1-2 in Fig. 1(b). To prove this, consider the related system of Fig. 1(c), consisting of a twisted pair of helical wires carrying equal and opposite currents inside a concentric superconducting circular cylinder. Since the same magnetic flux distribution is produced around the wires in Figs. 1(a) and 1(c), \mathbf{B} is the same, too. By symmetry, the magnetic field along any diameter located symmetrically between the wires in Fig. 1(c) has no z or θ components and is purely radial in the cylindrical coordinate system, like segment 1-2. Therefore, magnetic line 1-2-3 at the helical-D wall

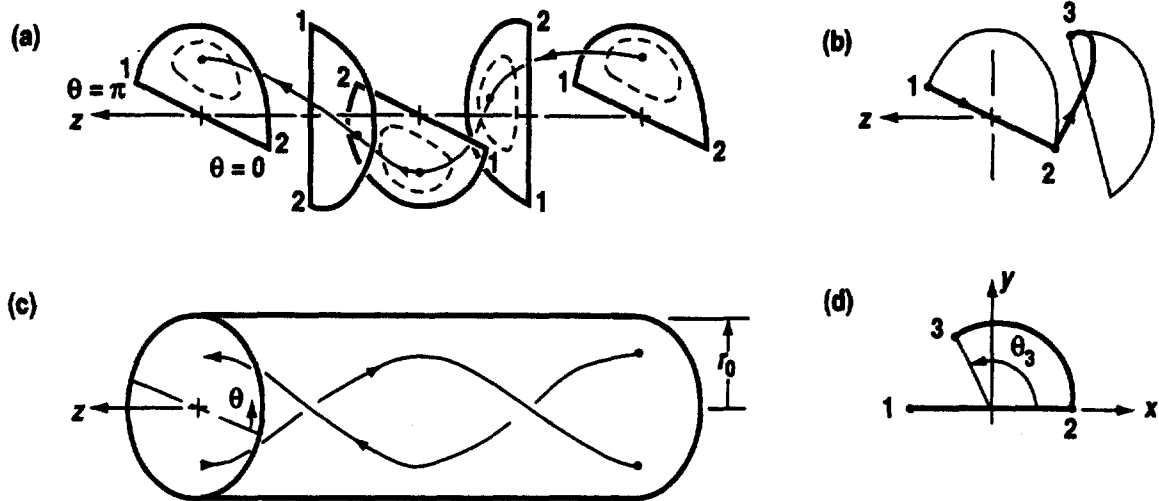

[Figs. 1(b, d)] has a transform in the negative- z direction. Pitch P , defined as the average advance in z divided by the number of radians of encirclement of the helical magnetic axis, is $P/r_0 = -\alpha r_0 / [2 + (\alpha r_0)^2]$ at the wall [4]. Here α is the inverse of the pitch of the helix. The maximum normalized pitch $|P/r_0|$ is $1/(2\sqrt{2}) \approx 0.35$ when $\alpha r_0 = 2$. The helical-D transform is produced *geometrically* by the helical symmetry and the flattened side (D cross section) and is much larger than that of conventional multipole helical coils. Numerical tracing of magnetic lines for a distributed “plasma” consisting of current only in the helically invariant (axial) direction shows that P varies approximately parabolically with average minor radius of the magnetic surface. Therefore, the transform is not only large, but it is also distributed throughout the plasma cross section to produce an RFP-like pitch profile.

RFPs achieve MHD stability by a combination of a strong magnetic shear, a monotonically varying (with minor radius) q or pitch profile, a nearby conducting wall and closeness to the Woltjer–Taylor relaxed or minimum energy state [5]. Monotonic pitch avoids the double tearing instability, and the relaxed state in a closely fitting conducting shell is stable against ideal and resistive tearing modes. The relaxed current distribution, $\mu_0 \mathbf{J} = \mu \mathbf{B}$ with μ a constant across the cross section, requires a large current near the edge, because $\mathbf{B} \cdot \mathbf{B}_\theta$ is large there. Constant μ is not fully attained in practice. In experimental RFPs the edge current decays naturally until mild instabilities grow and drive a dynamo that sustains a current distribution not too far from the relaxed one.

The helical–D pinch obtains large shear and pitch reversal by geometry rather than dynamo. However, the Ohmically determined \mathbf{J} profile will be centrally peaked rather than relaxed. It should be determined, for example by 3–dimensional resistive MHD computations, whether there exist shear–stabilized, unrelaxed, peaked– \mathbf{J} configurations that might be quieter than conventional RFPs. The search for favorable regimes should also include the unreversed regime ($0 < q < 1$), where unstable modes tearing at the low–rational q surfaces limit operation. Here the axial transform might be used to keep $q(r)$ entirely between two rational fractional values, for example between $1/2$ and $1/3$.

Conclusions

The helical–D geometry produces large magnetic line transforms that might enable quieter, low– q pinches, both reversed and unreversed, with improved confinement. The major physics question is whether a peaked, unrelaxed, Ohmic current profile will be stabilized by the applied transform, so that the listed benefits might be obtained.

Acknowledgments

This work was supported by the Phillips Petroleum Co. under Research and Development Agreement No. 01341, by the General Atomic Company and by the U.S. Department of Energy under Contract No. DE-AC03-89ER51114.

References

1. H.A.B. Bodin, R.A. Krakowski, S. Ortolani, *Fusion Technology* **10** (1986) 307.
2. J.S. Sarff, *et al.*, *Phys. Rev. Lett.* **78** (1997) 62.
3. T. Ohkawa, *et al.*, *Nucl. Fusion* **20** (1980) 1464.
4. M.J. Schaffer, U.S. Patent 4,734,247 (1988) and submitted to *Comments on Plas Phys. and Controlled Fusion* (1997).
5. J.B. Taylor, *Phys. Rev. Lett.* **33** (1974) 1139.

Resistive Kink-Mode-Stable, Higher Beta Reversed Field Pinch Configuration with RF Current Drive

Department of Materials Science,
Hiroshima University
K.Kusano

Department of Electronic Engineering,
Gunma University
Y.Kondoh

Atomic Energy Research Institute, College of Science and Technology,
Nihon University
M.Ogawa,H.Gesso,K.Saito and S.Shiina

The turbulent relaxation of reversed field pinch(RFP)plasmas can occur via resistive kink modes which saturate in amplitude[1,2]. One would therefore expect resistive kink-mode-stable configuration to reduce the turbulent level of MHD relaxation.

This report is concerning with the stability control of resistive kink-modes by rf current drive in partially relaxed state model (PRSM) RFP configuration [3], which has the higher stability beta limit of central beta value ~19% against both ideal kink modes and Suydam modes than that for pitch function RFP model [4]. As rf current driver, fast magnetosonic waves (FMW; $f \sim 10$ fDC) is used for some advantages over lower hybrid wave; the good accessibility to high density region, the strong absorption rate mainly due to TTMP especially in high beta plasmas such as RFP plasmas and the relatively high current driven efficiency[5-7]. The FMW current drive had been reported to be a prospective method to enable a quiet sustainment of the linearly unstable RFP configuration[8]. The stability analysis of PRSM-RFP plasma against resistive kink modes is investigated by solving numerically a linearized, compressible 3-D MHD equations including the terms of resistivity, viscosity, thermal conduction and pressure gradient. In the computation, the normalized viscosity is usually set equal to the normalized resistivity. Both the normalized viscosity and the normalized resistivity are assumed to be isotropic and constant in space and time. The growth rates of poloidal mode number $m=1$, toroidal mode number $n=1$ to 40 are obtained in the cases of Lundquist number $S=3 \times 10^3$ to 1×10^4 , aspect ratio $R/a=3$ and thermal conduction coefficient 1×10^{-4} . The plasma is bounded by a perfectly conducting wall.

The observed instabilities are internal resonant modes, which are associated with the peaking of the profile of ratio (force-free current)/ B and the increase of beta value. Increasing S number suppresses the growth rates of high n modes and decreases the maximum growth rates.

Conclusions

- (1) Resistive kink-mode-stable partially relaxed state RFP configuration have been obtained which in the central regions of the pinch are of the form given by Taylor and in the outer regions carry little or no current.
- (2) PRSM-RFP plasma with averaged poloidal beta 16.1% is stable against both resistive kink modes and Suydam modes.
- (3) The stability beta limit is enhanced to ~20% from 16.1% due to the flatter force-free current profile by rf current drive.
- (4) The wave power required for the enhanced stability becomes small and the current driving efficiency becomes large, with the increase of I/N at a fixed beta value.
- (5) Next problem to be solved for the resistive kink-mode-stable PRSM-RFP plasma is the non-linear instabilities driven by natural field diffusion, which modifies the linearly stable configuration and supplies the free energy for turbulent relaxation.

References

- [1] R.B.White, D.A. Monticello, M.N. Rosenbluth, B.V.Waddell, *Phys. Fluids* 20 (1977) 800.
- [2] K. Kusano, T. Sato, *Nuclear Fusion* 30 (1990)2075.
- [3] Y. Kondoh, *Nuclear Fusion* 21 (1981) 1607.
- [4] D.C. Robinson, *Nuclear Fusion* 18 (1978) 939.
- [5] S. Shiina, Y.Kondoh, H.Ishii, *Nuclear Fusion* 34 (1994)1473.
- [6] S. Shiina, Y.Kondoh, K.Saito, T.Shimada, T.Maekawa, *Fusion Engineering and Design* 26 (1995)259.
- [7] N. Kashiwagi, Y. Kondoh, K. Saito, S. Shiina, *Proc.ICPP (1996,Nagoya)* 9I08.
- [8] T. Nagai, K. Kusano, Y. Kondoh, S.Shiina and K. Nishikawa, *Proc. ICPP (1996,Nagoya)* 9I09.

HIGH- β RELAXED PLASMAS FOR FUSION APPLICATIONS

L.C. Steinhauer

Redmond Plasma Physics Laboratory, University of Washington

A. Ishida

Niigata University, Japan

The evolutions of a magnetofluids often exhibit complicated dynamical relaxations in which nonlinear processes modify their structure. Such relaxations are interesting because that they may not simply dissipate the magnetic field; instead they may preserve important global features known as invariants. In the process, the plasma self-organizes into *relaxed states*. The relaxation theory based on invariant magnetic helicity has had spectacular success in predicting the gross evolution and structure of reversed-field pinch (RFP) and spheromak plasmas. However, it has been less successful in predicting tokamak behavior and doesn't relate at all to field-reversed configurations (FRC). Missing from this theory are such nearly ubiquitous features as finite plasma pressure and significant flow. It is suggested that these shortcomings merely manifest the theory's incompleteness and need to be extended.

We present a more general relaxation theory based on a two-specie (ion and electron) magnetofluid [Ref. 1]. The new theory synthesizes familiar concepts: the relaxation of a magnetofluid; the two-fluid model of a magnetofluid; canonical momenta; helicities as invariants; and characteristic "integral" curves of the invariants. This formulation is more realistic than the magnetohydrodynamic (MHD, single-fluid) model on which the previous theory was based. The following argument offers motivation for using a two-fluid model. Magnetofluid relaxations proceed by means of reconnections in very thin layers. However, single-fluid behavior only holds for length scales somewhat larger than the collisionless skin depth. On the short length scales in reconnection layers, the ion and electron responses de-couple and the two-fluid treatment is necessary. Therefore, while the MHD theory may capture some aspects of relaxation, it will fail to predict others.

The invariants of a multi-specie magnetofluid, as will be shown, are the self helicities, $K_\alpha = (c^2/8\pi q_\alpha^2) \int P_\alpha \cdot \Omega_\alpha d\tau$, where $d\tau$ is a volume increment; and the integral is over the entire system volume. These are composite helicities, combining fluid and field behavior using the canonical momentum, $P_\alpha = m_\alpha u_\alpha + q_\alpha A/c$, and the canonical vorticity, $\Omega_\alpha = \nabla \times P_\alpha$; here A is the vector potential of the fields, and each specie (denoted by index α) has the charge, mass, density, pressure, and flow velocity, $q_\alpha, m_\alpha, n_\alpha, p_\alpha, u_\alpha$ respectively. The dimensional constant, $c^2/8\pi q_\alpha^2$, gives K_α energy-length units. The well-known simple helicities are the kinetic $K_t = \int u \cdot \omega d\tau$, cross $K_r = \int u \cdot B d\tau$, and magnetic $K_m = \int A \cdot B d\tau$, where $\omega = \nabla \times u$ is the fluid vorticity, and $B = \nabla \times A$ is the magnetic field. There is an obvious resemblance between the self- and simple helicities: for massless electrons, K_e is equivalent to K_m ; and K_i (expanding Eq. 1, and recognizing $u = u_i$) is a particular linear sum of the simple helicities. Indeed the two-fluid theory connects the simpler MHD (single fluid) and nonmagnetized fluid theories. These are, in fact,

reductions of the more general two-specie theory. Stated another way, the two-specie theory forms a bridge between the two simpler theories.

Four important questions must be answered in a new relaxation theory: (1) what are the basic invariants of the ideal system; (2) are the global forms of these invariants rugged (relatively durable); (3) what are the corresponding relaxed states; and (4) do the relaxations and the resulting equilibria predict experimental observations.

Basic invariants. Beginning from the foundation of Maxwell's equations and the equations of motion for each specie we derive the helicity transport equations, which govern the local evolutions of the helicities. Each local helicity is associated with a family of integral curves ("lines of force") that convect with a particular specie. Regarding the simple helicities, invariance rests on the assumption of vanishing electromechanical coupling (Lorentz force) on the ions, which is equivalent to adopting the ideal Ohm's law. Regarding the self helicities, the electromechanical coupling force does not appear in the helicity transport equations. Therefore the self helicities are the natural invariants in a two-fluid, while the simple helicities are the invariants in the reduced case of MHD. However, even a small level of dissipation unleashes reconnections that break the topology of the lines of force and destroy their identity; only the global form of each helicity survives.

Ruggedness. Even though the global form of an invariant is "safe" from topology changes, it may not survive under the action of nonlinear turbulence. This calls for a quasilinear analysis of wave processes on which tests of invariance can be based. The fluid-field coupling is expressed in terms of a magnetofluid coupling operator: this links the momenta of each specie to the "electromagnetic" momenta associated with the field, and depends on the frequency, ω and the wave vector k of the wave. These operators are preferable to the familiar dielectric function in that they distinguish the responses of each specie. A selection takes place between various fluid plasma waves in which the lowest energy wave dominates. There are three criteria for the ruggedness of helicities. The *cascade argument* considers the k -dependence of the waves compared with the k -dependence of the wave energy. This test shows that the self helicities (two-fluid) and the magnetic helicity (MHD) cascade downward in k (inverse cascade) compared with the wave energy, and thus are relatively invariant (rugged). The cross and kinetic helicities of MHD fail this test and thus are not rugged. The *selective decay argument* considers the relative decay rates of the helicities and the wave energy in thin reconnection layers: both self helicities decay more slowly than the energy. Proper application of this argument depends on recognition of the bounded nature of the viscous force and the unique two-fluid nature of the ion response at high k ; ignoring these two factors leads to an incorrect conclusion. Finally, the *time-scale argument* shows that the self helicities decay slower than the reconnection rate in a visco-resistive plasma

Relaxed states. Global invariants that survive the relaxation are suitable constraints in an energy minimization. This leads to three Euler equations describing the relaxed states: Ampere's law; and flow equations for both species in which the flow velocity is proportional to its canonical vorticity, with the Lagrange multipliers (used in

the variational procedure) as constants of proportionality. If boundary symmetry allows an angular momentum constraint, then the flow velocity is shifted accordingly. The system of equations is closed by the equation of motion, which takes the form of a Bernoulli equation linking the pressure and flow speed. In the reduction to MHD (dropping the ion self helicity invariant) the electron flow equation reverts to the familiar force-free condition.

Prediction of experiment. Assuming one-dimensional geometric analogies it is straightforward to find example relaxed states. Force-free states (included in the two-fluid theory) are well known. Presented here are FRC and tokamak examples that are outside the scope of MHD theory. The FRC example resembles laboratory plasmas, exhibiting *high- β* , no "toroidal" magnetic field, hollow current profile, significant rotational flow, and a natural plasma edge with thickness comparable to an ion gyroradius. The tokamak example resembles the core of reversed-magnetic shear experiments, exhibiting reversed magnetic shear, hollow current profile, and high flow speed. These examples represent aspects of qualitative agreement between the theory and experiment.

References

1. L.C. Steinhauer and A. Ishida, "*Relaxation of a two-specie magnetofluid*", accepted for publication in Phys. Rev. Lett., 1997.

Collisionless Pitch Angle Scattering and Related Loss Process of Plasma Particles in a Field-Reversed Configuration

Toshiki Takahashi,

The Graduate University for Advanced Studies, Toki-shi, Gifu 509-52, Japan

Yukihiro Tomita, Hiromu Momota,

The Graduate University for Advanced Studies, Toki-shi, Gifu 509-52, Japan

and National Institute for Fusion Science, Toki-shi, Gifu 509-52, Japan

and Nikita V. Shabrov

Moscow State Technical University, P.O.Box 38, Moscow 105007, Russia

A conceptual design [1] of a deuterium and helium-3 fueled fusion reactor based on a field-reversed configuration (FRC) has clarified its attractive characteristics in views of the cost of electricity, environmental effects, and resources. The design has, however, assumed Hoffman's scaling [2] modified by Kurtmullaev for plasma confinement as well as a utility of direct energy converters introduced into the design. It is true that plasma losses in an FRC have been studied[3] so far on the bases of the magnetohydrodynamics. Nevertheless, field-null points are formed at the edge region of an FRC and an application of the magneto-hydrodynamics is restricted within a certain domain in an FRC. The objectives of this paper is to extend discussions on plasma losses on the bases of reasonable plasma kinetic descriptions that allows us to apply the theory everywhere in an FRC. Non adiabatic behavior and related loss process of plasma particles locates near the separatrix of an FRC immersed into a magnetic mirror is the essential feature of the present work.

Accessible region [4] of a charged particle in an axisymmetric FRC is characterized by a quantity qPq . The quantity q and Pq represent respectively the charge and the canonical angular momentum of the particle, the latter quantity is a constant of motion in our axisymmetric configuration. In a case where the positive quantity qPq approaches zero, the accessible region approaches and ultimately involves the separatrix. The accessible region for this case is similar to that for a magnetic cusp point and henceforth we will refer this region to "cusp-like region." The cusp like region extends toward the external-mirror end where the motion of the particle is encircling. In the opposite case where a particle with relatively large qPq , no part of the accessible region penetrates inside the separatrix. The motion of a particle at the mirror region is always off-axis and gyrating, similar to that in the simple magnetic mirror. We will henceforth refer this accessible region to "mirror-like region."

An introduction of the canonical action integral J , defined by an integral of the radial momentum over a period in radius, appears relevant to characterize details of the motion of a charged particle. In terms of the action integral, one is able to describe the necessary and sufficient condition

for the particle loss of an FRC, because the value corresponds to the pitch angle in a relatively uniform magnetic field such as the midplane or the mirror points and determines ultimate particle loss through the magnetic mirror. If the action integral J of a particle that is directed to a mirror point is smaller than a certain value $J_c(H, Pq)$ described as a function of the Hamiltonian and the canonical angular momentum, then the particle will be lost through the magnetic mirror. On the contrary, if the action integral is larger than the value J_c , the particle will be confined within the magnetic mirrors.

A charged particle keeps its action integral during its excursion over a relatively uniform magnetic field. The motion reveals the adiabaticity breaking of a certain adiabatic variable. That is, an abrupt step-like change in the action integral takes place when a particle passes through the vicinity of an x -point. The trajectory changes instantaneously from off-axis gyrating one to encircling betatron or figure-8 one, and vice versa. Accordingly, linear integration J along the trajectory suffers from a rapid change. Since the amount of the change depends on the gyrating phase of the motion at a certain point, this process can be understood as stochastic. Thus we find a collisionless pitch angle scattering attributed to a stochastic change in action integral at the vicinity of an x -point.

The process of this pitch angle scattering has been verified numerically.

The obtained results are as follows:

- i) An isotropic scattering model is relevant to this case, since the distribution of the action integral J after the scattering tends to be the one obtained analytically by assuming isotropic scattering.
- ii) Correlation coefficients of the action integrals between before and after the scattering clarified that the transfer from the line-cusp region to the point-cusp region or their inverse transfer appears to be stochastic.

For a charged particle moving in the mirror-like region, we have the following results:

- iii) As the action integral J increases, then the particle motion tends to be adiabatic.
- iv) Non-adiabatic particles are observed, if their canonical angular momentum approach zero. On the other hand, as the absolute value of canonical angular momentum increases, its guiding center shifts far from an x -point and consequent particle's motion becomes regular.

On the bases of above stochastic pitch angle scattering model, one is able to describe a whole picture of particle loss processes in an FRC.

- 1: We assume a particle source deep inside the FRC plasma, where the accessible region locates within the separatrix.
- 2: The azimuthal component of its velocity changes stochastically, once in a while, due to collisions or turbulences. The canonical angular momentum changes accordingly and ultimately the flux surface at the time averaged position of the particle changes. Thus a particles suffer a diffusion from flux surface to flux surface due to particle's collisions or plasma turbulences. The loss flux of ion and electrons are essentially the same in this region.
- 3: Near the separatrix of an FRC, the accessible region of an ion is cusp-like and involves a field-null x-point. Charged particles (essentially ions) suffer from collisionless stochastic change in their action integral, in the vicinity of an x-point. Certain ions are consequently scattered into the loss-corn of the mirror magnetic field due to the collisionless stochastic pitch angle scattering. The magnitude of the collisional scattering is much smaller than the collisionless stochastic scattering at this region of a fusion plasma, while particle diffusion from flux surface to flux surface is due to particle's collisions or plasma turbulence. Thus, the additional mirror loss process near the separatrix might be appreciable in an FRC.
- 4: Far outside the separatrix, the collisionless stochastic change in the action integral decreases and residual collisional or turbulent mirror loss as well as diffusion from flux surface to flux surface is dominates.
- 5: Ambipolar potential appears at the mirror point, which control automatically the equal loss flux of ions and electrons.

As a result, a kinetic description of plasma loss processes has been exhibited and importance of the collisionless stochastic pitch angle scattering has been pointed out. Detailed and quantitative discussions will be presented at the meeting. Discussions on the self-consistent magnetic field will be discussed by the use of this result into a balance between particle sources and losses [5]. Energy losses and flux losses will be treated on the same line as the present work. Our discussions are based on the assumption that the majority of plasma ions are gyrating. Effects of high energy betatron particles, which have large kinetic momentum in the azimuthal component, will be discussed in the further studies. Details of the plasma turbulence are remained unknown.

DISCLAIMER

This document was prepared as an account of work sponsored by an agency of the United States Government. Neither the United States Government nor the University of California nor any of their employees, makes any warranty, express or implied, or assumes any legal liability or responsibility for the accuracy, completeness, or usefulness of any information, apparatus, product, or process disclosed, or represents that its use would not infringe privately owned rights. Reference herein to any specific commercial product, process, or service by trade name, trademark, manufacturer, or otherwise, does not necessarily constitute or imply its endorsement, recommendation, or favoring by the United States Government or the University of California. The views and opinions of authors expressed herein do not necessarily state or reflect those of the United States Government or the University of California, and shall not be used for advertising or product endorsement purposes.

This report has been reproduced
directly from the best available copy.

Available to DOE and DOE contractors from the
Office of Scientific and Technical Information
P.O. Box 62, Oak Ridge, TN 37831
Prices available from (615) 576-8401, FTS 626-8401

Available to the public from the
National Technical Information Service
U.S. Department of Commerce
5285 Port Royal Rd.,
Springfield, VA 22161