

THE BUNCH-BY-BUNCH TRANSVERS FEEDBACK SYSTEM AT VEPP-4M

G.V.Karpov, V.A.Kiselev N. I.Zinevich,
Budker Institute of Nuclear Physics, SB RAS, Novosibirsk,Ru

Abstract

In this paper the bunch-by-bunch transvers feedback system for suppression fast head- tail and coupled bunch instabilities is described. The experimental results of the feedback affecting on the current threshold are presented. The effects of the reactive and resistive feedback on the current threshold are discussed.

1 INTRODUCTION

The mode of operation of the VEPP-4M facility as a synchrotron light source intends 4 equally spaced along the ring bunches with each bunch average current of about 20 mA. The most fundamental limit for the bunch current at the VEPP-4M presently is vertical fast head-tail instability. The beam losses is usually observed in some tens of msec after injection (this corresponds approximately to the time of radiation damping), Fig. 1. The threshold current was 10±11 mA

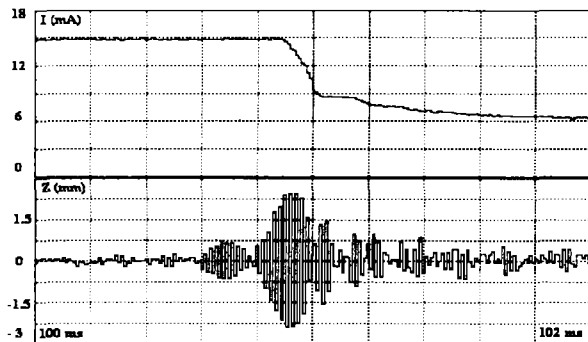

Fig. 1. The bunch head-tail instability after injection.

The fast head-tail instability occurs when frequency of the head-tail mode "0" is shifted sufficiently to couple to the "-1" mode. In order to increase an instability threshold it is usually suggested to introduce the reactive feedback to compensate frequency shift of the mode "0". However, as it follows from experiments [1] it is turned out that the introducing of the pure resistive feedback increases the threshold current up to substantially higher values.

This effect can be explained within the framework of the simple two particle model. In the papers [2,3] it was found the eigenmodes and eigenvalues of the particles oscillations in the bunch. It was shown that in the vicinity of instability threshold eigenmodes are approximately the same, they have close eigenvalues

and each mode has the approximately equal amplitudes of the dipole and quadrupole components.

When the resistive feedback is turned on an energy extraction occurs from the eigenmodes of oscillations excited by the head-tail interaction in a bunch through the dipole degree of freedom, thereby preventing the instability growth. This interpretation is additionally supported by the experimental data obtained at VEPP-4M [4].

In this paper the new bunch-by-bunch feedback system for suppression of vertical fast head-tail as well as coupled bunch instabilities is described.

The VEPP-4M related parameters are listed below.

Energy	1.8-5.5 Gev
Rev. frequency, f_{rev}	0.819 MHz
RF frequency	180 MHz
Number of bunches	4
Radiation dumping time at injection (long., trans.)	30-60 ms
Bunch length (injection)	20cm
Tune, vertical	7.59
Tune, longitudinal	0.018
Bunch current threshold	10-11 mA

2 DESCRIPTION OF THE SYSTEM

The block diagram of the feedback system over the vertical dipole oscillations of a beam is given in Fig.2. The 50 Ohm striplines are used as the pickup of transverse oscillations. The signals from the opposite striplines are applied to the subtracting transformer having the input impedance equal to the wave impedance of striplines that enable us to separate the signals from the electron and positron bunches. The length of striplines was chosen in such a way that their sensitivity has maximum values in the frequency range 150±250 MHz.

The signals from four electron bunches are switched to four corresponding channels by front end GaAs FET switches. The gate duration is chosen to be 150 ns to provide bunch to bunch signals isolation. The Finite Impulse Response (FIR) filter converts alternative impulse from the transformer output to 7 cycle sine-like burst at the RF frequency. This provides better conformity of the transformer output signals to the dynamic range of the following switches.

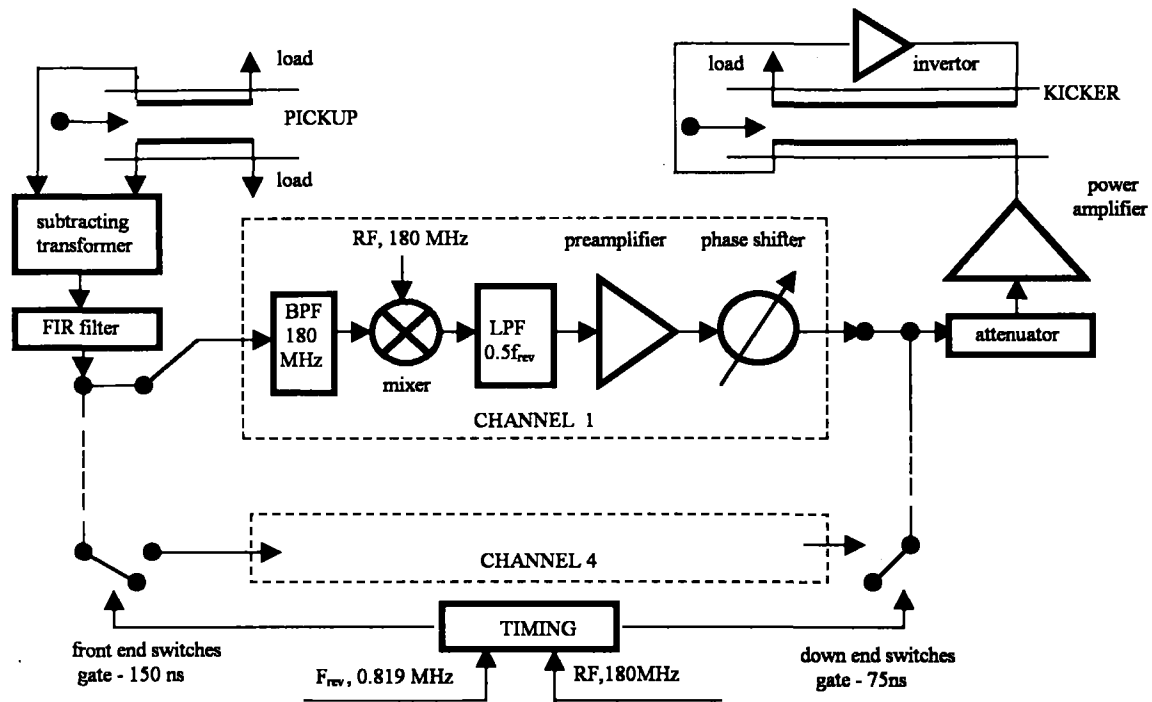

Fig.2. The feedback system blok diagram.

Each channel consist of selective filter tuned at the RF frequency 180 MHz, frequency converter where the bunch signal is mixed with RF signal from accelerating system, Low Pass Filter with cutoff frequency of $0.5 \cdot f_{rev}$, preamplifier and phase shifter. The phase is regulated within the range $0 \div 2 \cdot \pi$ thus enabling both the resistive and reactive feedback. The down end switches provide the delivery the channels feedback signals through the attenuator, power amplifier and kicker to "own" bunches only. The gate duration is 75 ns. The channels isolation defined by front end switches is more than 40 dB.

The pair of the 50 Ohm diametrically opposite matched striplines of 1 m length is used as a kicker. The power applying to the striplines is in series with the use of the inverter transformer. The inter-lines maximum voltage is limited by the power of an output amplifier to the value of 600 V.

3 EXPERIMENTAL RESULTS

The finite dynamic range of the feedback system imposes the limit to the decrement at injection where the bunch oscillation amplitude is quite large because of errors in the injection systems. In our case, at the bunch current of ~ 10 mA this value was approximately $0.03 \cdot f_{rev}$ and for lower amplitudes of oscillations it could be increased up to $0.1 \cdot f_{rev}$. The coherent tune shift, produced by the feedback, corresponding to these two modes of operation was $2 \cdot \pi$ times lower. The ring coherent tune shift caused by the bunch interaction with the storage ring

components was 0.012 at the same current value. The summarized feedback parameters at the bunch current of ~ 10 mA are presented below.

Channels number	4
Channels isolation	40 dB
Kicker length	1 m
Max. kicker voltage	600 V
Decrement at injection	$0.03 f_{rev}$
Max. decrement	$0.1 f_{rev}$
Max. coherent tune shift	0.016
Ring coherent tune shift	0.012

The experiments with the feedback system was performed at VEPP-4M facility at April – March, 1998. Unfortunately, the VEPP-4M could operate only with two bunches in the ring because longitudinal coupled bunch instability. The best results obtained were under the resistive – reactive feedback. The reactive part of the feedback provided decreasing the ring coherent tune shift. The optimum phase was, approximately, the mean phase between 0 (resistive feedback) and $\pi/2$ (reactive feedback). It was reached that maximum captured and accelerated current in two bunches were 40 mA and 36 mA, accordingly. So, the threshold current is exceeded approximately by two. One should note that maximum captured current in our case is limited not by feedback capabilities but the maximum current of the injected bunch (there is one injection in one bucket).

The results give evidence an efficiency of the resistive - reactive feedback in suppression of the fast

head-tail instability and can be used at other accelerators for the development of similar systems.

4 REFERENCES

[1] S.Myers, " Stabilization of fast head-tail instability by feedback ", Proc. of IEEE Particle Accelerators 1987.

[2] A.Chao, SLAC-PUB-2946, June 1982.

[3] M.M. Karliner, private communication, 1994.

[4] M.M. Karliner et. al., "The feedback system for elimination the fast head-tail instability at storage ring VEPP-4M", EPAC 96, Barcelona, 1996.