

National Research Tomsk Polytechnic University

Institute of High Current Electronics SB RAS

**3rd International Congress
on Radiation Physics and Chemistry
of Condensed Matter,
High Current Electronics and
Modification of Materials with
Particle Beams and Plasma Flows**

Abstracts

Tomsk

2012

Committee

Chairman

G. Mesyats, Vice-President, Russian Academy of Sciences

Chairman of Organizing Committee

P. Chubik, Rector, National Research Tomsk Polytechnic University

Chairman of Program Committee

N. Ratakhin, Director, Institute of High Current Electronics SB RAS

15th International Conference on Radiation Physics and Chemistry of Condensed Matter

Co-Chairmen:

Viktor Lisitsyn, Institute of High-Technology Physics, TPU, Tomsk, Russia

Vladimir Lopatin, Institute of High-Technology Physics, TPU, Tomsk, Russia

11th International Conference on Modification of Materials with Particle Beams and Plasma Flows

Co-Chairmen:

Nikolai Koval, Institute of High Current Electronics SB RAS, Tomsk, Russia

Valery Krivobokov, Institute of Physics and Technology, TPU, Tomsk, Russia

17th International Symposium on High Current Electronics

Co-Chairmen:

Boris Kovalchuk, Institute of High Current Electronics SB RAS, Tomsk, Russia

Gennady Remnev, Institute of High-Technology Physics, TPU, Tomsk, Russia

Supported by

Russian Foundation for Basic Research

**HARD NANOCOMPOSITE COATINGS: THERMAL STABILITY,
OXIDATION RESISTANCE AND TOUGHNESS**

J. Musil

*Department of Physics, Faculty of Applied Sciences, University of West Bohemia, Univerzitní 22,
CZ-306 14 Plzeň, Czech Republic, musil@kfy.zcu.cz*

The lecture is divided in three parts. The first part is devoted to the enhanced hardness of nanocomposite coatings and reasons of its rise. It gives a brief survey of the present state of the knowledge in the field of hard nanocomposite coatings [1]. The second part is devoted to the thermal stability of nanocomposite coatings, thermal cycling of nanocomposite coatings and formation of amorphous coatings with thermal stability and oxidation resistance above 1000°C using sputtering. As examples, (i) nc-t-ZrO₂/a-SiO₂ nanocomposite coatings resistant to thermal cycling in air up to 1400°C [2] and (ii) a-(Si₃N₄/MeN_x) and a-(Si-B-C-N) amorphous coatings thermally stable and resistant to oxidation in air above 1000°C [3] are reported. The third part reports on new advanced hard nanocomposite coatings with enhanced toughness, particularly (i) NG/AM composite coatings composed of nanograins (NG) dispersed in an amorphous matrix (AM) and (ii) highly-elastic composite coatings resistant to cracking. As examples, (i) nc-TiC/a-C nanocomposite coatings with low friction and wear and (ii) Zr-Al-O [4], Al-Cu-O oxide composite coatings [5] and Al-O-N nitride/oxide nanocomposite coatings [6] with hardness $H \approx 18$ GPa, low Young's modulus E satisfying condition $H/E > 0.1$, high elastic recovery $W_e \geq 70\%$ and strongly enhanced resistance to cracking are reported in detail. It is shown that the hard coatings with enhanced toughness represent a new class of advanced protective and functional coatings with a huge application potential. At the end, trends of next development of the advanced hard nanocomposite coatings are outlined.

References

- [1] J.Musil: Physical and mechanical properties of hard nanocomposite films prepared by reactive magnetron sputtering, Chapter 10 in the book "Nanostructured Hard Coatings", 2005, Springer Science+Business Media, LCC, New York, NY 10013, U.S.A., pp. 407-463.
- [2] J.Musil, V.Šatava, P.Zeman, R.Čerstvý: Protective Zr-containing SiO₂ coatings resistant to thermal cycling in air up to 1400°C, Surf.Coat.Technol. 203 (2009), 1502-1507.
- [3] J.Musil, J.Vlček and P.Zeman: Advanced amorphous non-oxide coatings with oxidation resistance above 1000°C, Advances in Applied Ceramics 107(3) (2008), 148-154.
- [4] J.Musil, J.Sklenka, R.Čerstvý: Transparent Zr-Al-O nanocomposite coatings with enhanced resistance to cracking, Surf.Coat.Technol. 206 (2012), 2105-2109.
- [5] J.Blazek, J.Musil, P.Stupka, R.Cerstvy, J.Houska: Properties of nanocrystalline Al-Cu-O films reactively sputtered by DC pulse dual magnetron, Appl.Surf.Sci. 258 (2011), 1762-1767.
- [6] J.Musil, M.Meissner, R.Jilek, T.Tolg, R.Cerstvy: Two-phase single layer Al-O-N nanocomposite films with enhanced resistance to cracking, Surf.Coat.Technol. (2012), submitted for publication on December 22, 2011.

**OPERATING THE FIRST WATER-INSULATED MYKONOS II LTD
VOLTAGE ADDER**

**M. G. Mazarakis¹, A. A. Kim², M. E. Savage¹, W. E. Fowler¹,
K. LeChien³, D. J. Lucero¹, M. K. Matzen¹, R. G. McKee¹, G. Natoni¹,
J. L. Porter¹, S. A. Roznowski¹, V. A. Sinebryukhov², B. S. Stoltzfus¹,
W. A. Stygar¹, P. E. Wakeland¹.**

¹*Sandia National Laboratories Albuquerque, N.M. 87185 USA,
mgmazar@sandia.gov*

High Current Electronic Institute (HCEI), Tomsk, Russia and

²*Tomsk Polytechnic University, Tomsk 634050, Russia, kim@oit.hcei.tsc.ru*

³*NNSA, Washington DC, USA*

The LTD technological approach can result in very compact devices that can deliver very fast, high current and high voltage pulses straight out of the cavity without any complicated pulse forming and pulse compression network. Because the output pulse rise time and width can be easily tailored (pulse shaped) to the specific application needs, the load may be a vacuum electron diode, a z-pinch wire array, a gas puff, a liner, an isentropic compression load (ICE) to study material behavior under very high magnetic fields, or a fusion energy (IFE) target. Ten 1-MA LTD cavities were designed and built in the High Current Electronic Institute (HCEI) at Tomsk, Russia, under a Sandia Laboratory contract. The cavities were originally designed to run in a vacuum or Magnetic Insulated Transmission Line (MITL) voltage adder configuration. Following successful operation in this mode, we are gradually modifying them to make them capable of operating assembled in a de-ionized water insulated voltage adder. Special care is being taken to clean by filtration, remove dissolved and free water, and de-aerate the oil of the cavities. Similar treatment is effectuated on the water of the voltage adder in addition to deionization and bubble removal. To that effect two continuously operating water and oil re-circulating systems were designed and built. One of the most important LTD driver applications (IFE) will require tens of thousands of shots without interruption. Presently, we are operating two modified cavities with more robust components and specially designed for water

insulation “O” rings and grooves. Lifetime experiments of the voltage adder will be done with a matched liquid resistor load. If the modifications are proved successful, similar changes will be implemented in the remaining eight cavities. Our goal is to have the LTD MYKONOS X voltage adder operating with all ten cavities as soon as possible in a water insulated mode.

**FORMATION AND EVOLUTION OF THE RADIATION DEFECT
IN THE IONIC CRYSTAL**

V.M. Lisitsyn

National Research Tomsk Polytechnic University, Tomsk, Russia

Radiation defects in ion crystals are effectively formed in the process of electron excitation decay. In the primary event of decay correlated pairs of F- and H-centers type are formed, which then spatially disintegrate and annihilate via thermoactivated motion of the mobile pair component. In the experimental conditions the disintegrated components are transformed into stable pairs. In imperfect crystals the processes of decaying electron excitation localization and transformation of radiation defects are affected by inherent imperfection of the crystals. The formation of electron excitations and their following decay into pairs of radiation defects is possible under high power pulsed laser action as well.

**15th International
Conference
of Radiation Physics
and Chemistry
of Condensed Matter**

PREPARATION AND OPTICAL PROPERTIES OF TITANIUM DIOXIDE NANOPOWDER

**Y. K. Abdel-Moneam¹, E. F. Polissadova², H. A. Othman¹:
M. M. Madkour³**

¹ Faculty of Science, Menoufiya University, Shebin El-Kom, Egypt
E-mail: hosamssl4@yahoo.com

² Tomsk polytechnic university, Tomsk, Russia, E-mail: elp@tpu.ru

³ Chemistry department, Faculty of Science, Kuwait University,
Safat, Kuwait.

Nanometer sized TiO₂ NPs with average particle size 6.7 nm were synthesized via hydrolysis of TiCl₄ in alcoholic-aqueous solution. Evidenced by TGA, the synthesized nanoparticles are very stable in air and no decomposition took place in the range of 20-800 °C. characteristics of the UV-Vis absorption, and cathode-luminescence spectra of the prepared NPs attributed to the transitions of self trapped excitons. The synthesized NPs were also characterized by XRD, TEM, XPS, and DLS, measurements.

FIRST-PRINCIPLES CALCULATIONS OF RADIATION DEFECTS IN MAGNESIUM FLUORITE

**F.U.Abuova¹, A.B.Useinov¹, A.T. Akilbekov¹, E.A. Kotomin²,
S.Piskunov²**

¹L. N. Gumilyov Eurasian National University, Astana, Kazakhstan
Fatika_82@mail.ru ²Institute of Solid State Physics, University of Latvia,
Riga. Kotomin@latnet.lv

MgF₂ with rutile structure is important wide-gap optical material with numerous applications. It is also radiation-resistant material, the energy required to form a stable primary radiation defect known as the *F* center (fluorine vacancy with trapped electron) between 5K and room temperature is much higher than in other alkali halides. We present and discuss here the results of calculations for basic colour centers (F⁻, H⁻, Frenkel defects) in the crystal bulk. This study is based on the large scale *ab initio* DFT calculations

using hybrid B3PW exchange-correlation functional as implemented into CRYSTAL code.

In order to understand the behaviour of the material with respect to irradiation and its optical properties, we analyzed the electronic structure, atomic geometry, charge density distribution as well as defect- and surface formation energies using several types of supercells. We compared properties of close and well separated F-H (Frenkel) defect pairs and migration of defects. We simulated also formation and demonstrated energetic preference of inert F₂ interstitial molecules as sinks of mobile interstitials atoms. We discuss how this is related to the material radiation stability.

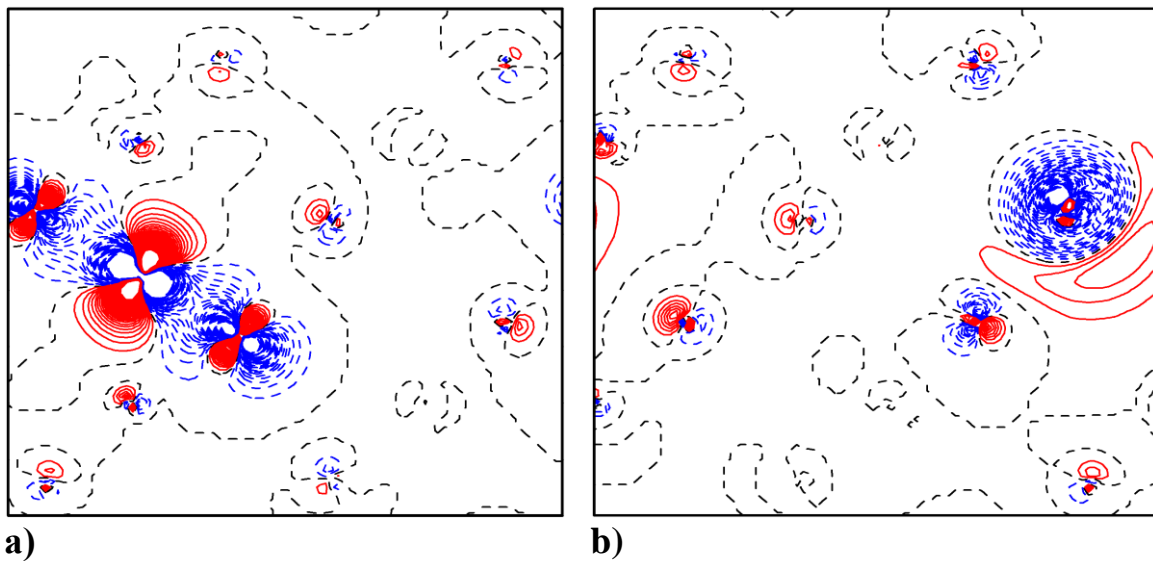

The electronic density redistribution around the H center (a) и F center b).

COLORATION MECHANISM OF CsI(Tl) UNDER IRRADIATION

**V.D. Alekseev, L.N. Trefilova¹, V.Yu. Yakovlev², A.N. Meleshko²,
T.A.Charkina¹**

Institute for Scintillation Materials of NASU, Kharkov, Ukraine, alekseev@isma.kharkov.ua

¹ *Institute for Scintillation Materials of NASU, Kharkov, Ukraine, shpil@isc.kharkov.com*

² *Tomsk Polytechnic University, Tomsk, Russia, yak999@rambler.ru*

According to [1] $Tl^0v_a^+$ and F- centers arise in KCl(Tl) under irradiation, but we have found that irradiation of CsI(Tl) gives rise to electron activator color centers which are responsible for bands with maxima at 430, 520, 560, 840 and 970 nm without giving rise to F-band at 790nm. Such an occurrence can be explained by the behavior of initial Frenkel defects: neutral (F-H) and charged (\square -I) pairs. According to [2,3] activation energy for spatial separation of F-H pairs in KCl and CsI is 0.07eV and 0.22 eV, respectively. The pairs in CsI recombine in microsecond time scale owing to high activation energy, without giving rise to stable F-centers. As for (\square -I) pairs, probability of their separation is significantly higher than that of (F-H) pairs. Absorption band of α -centers is observed in the spectra measured with time resolution in second time scale [4] and without time resolution after high dose irradiation [5]. In addition to α -centers, F- and F-aggregate centers arise in heavily irradiated CsI crystals due to the \square -centers (anionic vacancies) which capture conduction electrons [2,3].

According to our results, irradiation of CsI(Tl) gives rise to the stable activator centers, at temperature higher 200K and at Tl concentration not less than 0.01mol%. It means that the number of Tl^+ -ions is overwhelmingly bigger than that of α centers in CsI(Tl) therefore only Tl^+ -ions capture electrons, forming Tl^0 centers. $Tl^0v_a^+$ -center is formed by the attraction of the anion vacancy to a negatively charged Tl^0 center. We have found that only electron $Tl^0v_a^+$ and hole $(I_3^-)_{aca}$ centers arise at a light dose of irradiation but at a higher dose some activator centers arise which are responsible for bands at 390 and 465nm. These centers can also be formed by disintegration of $Tl^0v_a^+$ centers initiated by UV light illumination. We think that V_k or H center as well as cation vacancy v_c^- arise in CsI(Tl) owing to a recombination of delocalized electron with $(I_3^-)_{aca}$ center. They interact with Tl^+ -ions, forming hole-activator $Tl^{2+}v_c^-$ centers.

Our interpretation of the structure of $Tl^0v_a^+$ and $Tl^{2+}v_c^-$ centers is proved by the results of the following experiments: 1) the number of $Tl^0v_a^+$ and $Tl^{2+}v_c^-$ increases in crystals which were either deformed or exposed to high temperature in order to intensify the concentration of v_a^+ and v_c^- ; 2) the intensity of the bands for $Tl^0v_a^+$ changes inversely to that of $Tl^{2+}v_c^-$ in minute time scale once the irradiation or illumination is ceased.

[1] E. Goovaerts, J. Andriessen, N. Nistor, D Schoemaker. Electron-spin-resonance study of Tl atom defects in KCl and relativistic many-body analysis of the hyperfine structure // *Phys. Rev.B*, 1981, V.24, pp.29-50.

[2] V.M. Lisitsyn, V.I. Korepanov, V.Y Yakovlev. Evolution of initial radiation defects in ionic materials // *Izvestia vuzov. Fizika*. 1996, V11. pp.5-29 (in Russian).

[3] E. S. Gafiatulina, S. A. Chernov, V. Y. Yakovlev. Creation of excitons and defects in CsI crystal under electron pulse irradiation // *Phys. Solid State*, 1998, V.40, pp.640-644 (in Russian).

[4] V.Y Yakovlev. Formation of color centers under pulse electron excitation // *Phys. Solid State*, 1984, V 26, pp. 3334–3337 (in Russian).

[5] I. Garapyn, B. Pavlyk, B. Tsybulyak. Radiation-induced processes and defects in purified CsI crystals // *Functional materials*, 2007, Vol.14, pp.309-312.

THE IMPACT OF Ba^{2+} AND SO_4^{2-} ON THE EFFICIENCY OF PEROXYNITRITE FORMATION UNDER PHOTOLYSIS OF KNO_3

V.A. Anan'ev, L. D. Kriger, I. A. Sorokina, A. B. Belyh

*Kemerovo State University, Kemerovo, Russian Federation,
eprlab@kemsu.ru*

Recently, it has been found out that it is peroxyxynitrite that is the main product of transformation of the nitrate ion in solids under photolysis (253.7 nm). It is evident that to find out the mechanism of the impact of the point defects on photolysis of crystalline nitrates, it is necessary to study their influence on the efficiency of the peroxyxynitrite formation.

The goal of the present paper is to determine the impact of both Ba^{2+} and SO_4^{2-} on the peroxyxynitrite accumulation in UV-irradiated (253.7 nm) crystalline KNO_3 .

Potassium nitrate crystals, both pure and doped, were grown by slow evaporation of saturated aqueous solutions. The salts used were a.r. grade (three times crystallized from redistilled water before use). In every instance the plates (1 cm×0.5 cm) were polished parallel to the crystallographic z -axis of both pure and doped KNO_3 crystals.

The samples were irradiated at room temperature with a low pressure mercury lamp. An analyzing and photolyzing non-polarized light beam was directed perpendicularly to the surface of the plates. The spectra were registered by means of a “Shimadzu UV 2450” spectrophotometer at room temperature.

The peroxyxynitrite content in the sample was calculated on the basis of the data on its concentration in the solution obtained after dissolving the sample. For this purpose we used iodometrical method. Moreover the peroxyxynitrite content in the sample was directly determined by optical measurements.

The introduce of Ba^{2+} in crystalline KNO_3 by co-crystallization results in 30 % decrease in the peroxyxynitrite quantum yield. The introduce of SO_4^{2-} is not affected on the one. Photolysis of doped crystals results in decrease of the peroxyxynitrite steady-state concentration. The mechanism for the impact of impurities on photolysis of crystalline KNO_3 has been discussed.

PARTICLE-IN-CELL SIMULATION OF POLARIZATION RADIATION

K. P. Artyomov^{1,2}, V. V. Ryzhov^{1,2}, V. P. Tarakanov³

¹ *Institute of High Current Electronics SB RAS, Tomsk, Russia,
artyomov@to.hcei.tsc.ru*

² *Tomsk Polytechnic University, Tomsk, Russia*

³ *Joint Institute for High Temperatures of the Russian Academy of Sciences, Moscow, Russia*

Different types of polarization radiation generated by a relativistic electron beam are simulated using fully electromagnetic particle-in-cell (PIC) code KARAT. The simulation results for diffraction radiation, transition radiation, Smith-Purcell radiation and Vavilov-Cherenkov radiation are in a good agreement with experimental data and analytical models.

**GEOMETRIC ANHARMONICITY WITHAN EXAMPLE OF
MODEL CALCULATIONS FOR POLYETHYLENE**

N. M. Badyrova

*Irkutsk State Technical University, Irkutsk, Russia,
mrk2@mail.ru*

The phenomena of anharmonicity plays a significant role for research in various areas of the experimental and theoretical physics.

This work is dedicated to the calculation of the energy for IR-transitions corresponding to the valence bond vibrations and valence angles of the polyethylene molecule. The calculations are performed with the aid of the formalism of polynomials of quantum numbers. This formalism is convenient to calculate the eigenvalues and eigenfunctions of anharmonic Hamiltonian and allows one to evaluate the matrix elements of an arbitrary coordinate function.

The expression for the energy of anharmonic vibrations is obtained in the second order of the polynomial perturbation theory. These expressions provide results that are satisfactorily agreed with the current experimental data.

For the fundamental transition ($n = 0 \rightarrow n = 1$, in which n is the vibrational quantum number),for the valence bond vibrations, the energy shift equals

and, for the valence angles,

**CORRELATING POLARIZED COMPONENTS OF ROTATING
CRYSTAL COLOR CENTERS LUMINESCENCE**

D. B. Baskakov, S. A. Zilov, A. L. Rakewitch

*Irkutsk branch of Institute of Laser Physics, Irkutsk, Russia,
zilov@ilph.irk.ru*

It is known that the intensity of polarized luminescence components of color centers in crystals is dependent on reciprocal orientation of exciting laser beam polarization vector, polarizer mounted before detector and the crystal itself [1]. The work reported is devoted to application of fluorescence correlation spectroscopy method [2] to observation of rotating crystal under this consideration.

The following concepts are done with. The crystal having color centers in it is being rotated around exciting laser beam axis. It contains color centers being described with quantum transition moments d_i , directed along crystal symmetry axes. Exciting beam has polarization state ε , and there are M detectors recording intensity time dependence of luminescence components with polarization state ε_j . So, M autocorrelation functions and C_M^2 crosscorrelation functions can be calculated. All these functions can be calculated both in general and for given d_i , ε and ε_j , and all of them are dependent only on crystal rotating rate and the mean number of color centers in observation volume.

There was direct calculation done for the color centers, oriented along C_3 cubic crystal symmetry axes and being excited with linearly polarized light, with the detection of two mutually orthogonal linearly polarized luminescence components. There are two autocorrelation and one crosscorrelation functions calculated:

$$\begin{cases} G_{\parallel}(\tau) = \frac{49}{50N}e^{-\frac{3}{2}k\tau} + \frac{48}{25N}e^{-k\tau}, \\ G_{\perp}(\tau) = \frac{1}{2N}e^{-\frac{3}{2}k\tau}, \\ G_{\parallel\perp}(\tau) = -\frac{7}{10N}e^{-\frac{3}{2}k\tau}. \end{cases}$$

There N represents number of color centers located simultaneously in the observation volume, and k is the frequency of crystal rotation.

The method presented can be used for both color center concentration determination and optical surface quality control. The former is obvious because of correlation functions dependence on N with given observation volume, while the later is possible due to the following consideration. The crosscorrelation function presented above has negative sign, while the one calculated for two cophased signals, for example, for two intensity components, modulated by crystal surface defects, is definitely positive. So, the

crosscorrelation function represents a sensitive instrument to optical surface heterogeneities, and autocorrelation functions are such instruments, too.

The consideration can be generalized for any media with luminescence centers in it, whose transition moment directions are fixed along its own symmetry axes. The method was also tested experimentally with F₂ color centers in LiF crystal, so the good and bad surface states were observed while exciting it with 470 nm laser and detecting luminescence in F₂ luminescence band while the crystal was rotated with the frequency about 10 to 30 full turns per second. The concentrations of centers was not however calculated because of technical difficulties connected with rotating crystal together with its very small part being monitored.

[1]. P.P. Feofilov. Polarized luminescence of atoms, molecules and crystals. / Moscow state publishers on physical and mathematical literature, 1959.– 288 p.

[2]. Petra Schwille, Elke Haustein. Fluorescence Correlation Spectroscopy: An Introduction to its Concepts and Applications. //Max-Planck-Institute for Biophysical Chemistry, 2004.

OPTICAL SPECTROSCOPY OF ALKALINE EARTH METAL FLUORIDE CRYSTALS UNDER CASCADE AND SIMULTANEOUS PULSED EXCITATION

E. P. Chinkov, V. F. Shtan'ko, S. A. Stepanov

*National Research Tomsk Polytechnic University, Tomsk, Russia,
stepanovsa@tpu.ru*

Optical spectroscopy with nanosecond resolution is used to study the spectral and kinetic characteristics of the optical absorption and luminescence in CaF₂, SrF₂, and BaF₂ crystals under the pulsed electron beam. Fluorite crystals irradiation with pulsed electron beam at up to room temperatures leads to effective formation of self-trapped excitons (STE), which are considered as different configurations of closely-spaced F and H centers. Stimulated emission of A₂B₆ type semiconductors is used for simultaneous additional excitation of fluorite crystals in the region of absorption of STE electronic components. It is found that synchronous optical irradiation with semiconductor stimulated emission decreases the efficiency of

STE formation in CaF_2 , SrF_2 , and BaF_2 . The evidence for this statement is a selective decrease in absorption spectrum of STE along with the luminescence intensity decrease. Fast emission with decay time shorter than the measurement channel time resolution (<7 ns) is observed at the high-energy slope of STE radiative annihilation band under the simultaneous irradiation with semiconductor stimulated emission. Spectral and kinetic parameters of this fast luminescence appearing in BaF_2 crystal under pulsed electron irradiation and simultaneous irradiation with semiconductor stimulated emission are similar to those of radiation, previously attributed to the core-valence transitions. The fast emission in UV spectrum region of CaF_2 , SrF_2 , and BaF_2 crystals is attributed to radiative electron transitions from the upper excited states. The different configurations of STEs are not formed in this case. The reasons of fast luminescence absence in CaF_2 and SrF_2 under the pulsed electron irradiation are discussed.

**COMPLEX EMISSION CENTERS IN SCINTILLATOR
 $\text{LiF}(\text{WO}_3)$**

**I.N. Dubtsov, L.N. Trefilova¹, L. A. Lisitsyna², N. N. Timoshenko¹,
O.V. Zelenskaya¹,
L. V. Gudzenko³, D. S. Sofronov⁴**

Institute for Scintillation Materials of NASU, Kharkov, Ukraine, ig-or8870@ukr.net¹ Institute for Scintillation Materials of NASU, Kharkov, Ukraine, shpil@isc.kharkov.com

² *Tomsk Polytechnic University, Tomsk, Russia, lisitsyna@mail.ru*

³ *Institute for Single Crystals of NASU, Kharkov, Ukraine, gayduk@isc.kharkov.com*

⁴ *STC "Institute for single crystals" of NASU, Kharkov, Ukraine, sofronov@isc.kharkov.com*

This paper studies the absorption and luminescence of LiF doped with tungsten oxide. A bulk of $\text{LiF}(\text{WO}_3)$ with size $\text{Ø}240 \times 400 \text{ mm}^3$ has been grown by Kyropoulos method in argon. Samples with size $15 \times 15 \times 3 \text{ mm}^3$ have been cleaved along the growth axis of the bulk. The concentration of W has been evaluated by chemical analysis, and the concentration of oxygen containing ions by vibration absorption spectra. It has been found that the W spreads throughout the bulk unevenly, having the concentration 0.011 mass%

and 0.32 mass%, at the beginning and the end of growth, respectively. We have observed two bands at 3620 cm^{-1} and 3723 cm^{-1} in the vibration absorption spectra of the samples. The band at 3723 cm^{-1} is caused by those OH^- ions which are found amidst LiF lattice ions. The band at 3620 cm^{-1} , we think, ought to be caused by those OH^- ions which are under of W^{6+} -ions perturbation, since the intensity of the band at 3620 cm^{-1} is directly proportional to W concentration, and the ratio of intensity of the band at 3620 cm^{-1} to the band at 3723 cm^{-1} increases from the beginning till the end of the crystal growth. Argon contaminated with water or salt contaminated with hydroxide can be responsible for the origin of OH^- in the crystal.

The samples $\text{LiF}(\text{WO}_3)$ have responded with an emission to ionizing radiation and thermal neutrons. The radio-luminescence spectra of $\text{LiF}(\text{WO}_3)$ measured under excitation with γ -radiation of ^{241}Am at 295K are well fitted by the sum of three bands at 4.4, 3.1 and 2.8 eV. The first two bands are attributed to α - and $\text{O}^{2-}\text{-v}_a^+$ centers in LiF , respectively, and the third band can be attributed to O^{2-} ions under of W^{6+} -ions perturbation. The scintillation output as well as the relative intensity of the band at 2.8 eV increase with the concentration of W from 0.011 to 0.32 mass%.

It has been found that right after a short series of electron pulses new emission centers arise in the samples at $T = 15\text{K}$. Their emission spectrum, which are typical for O_2^- -centers, consist of eight equidistant bands within the region 2.1 - 3.2 eV. After electron pulse irradiation OH^- -ions dissociate in O^- and H^0 and if those ions are found not far from each other then their O^- can react with each other into O^{2-} ion and anionic vacancy.

We have concluded that the emission center that gives rise to the band at 2.8 eV as well as the equidistant bands consists of W^{6+} ions amidst O^{2-} and OH^- ions and probably cation vacancies. Ions O^{2-} and cation vacancies neutralize the positive charge of W^{6+} .

UV-LUMINESCENCE IN Lu_2SiO_5 -Ce AND $\text{Lu}_2\text{Si}_2\text{O}_7$ -Ce CRYSTALS AT VUV- AND SOFT X-RAY EXCITATION

**V. Yu. Ivanov, I. N. Sedunova, I. V. Gerasymov¹, O. Ts. Sidletskiy¹,
V. A. Pustovarov**

Yeltsin Ural Federal University, Yekaterinburg, Russia, ivy@dpt.ustu.ru

¹ *Institute for Scintillation Materials NASU, Kharkiv, Ukraine,
gerasimov@isma.kharkov.ua*

Oxyorthosilicates and pyrosilicates doped with cerium (Lu_2SiO_5 -Ce (LSO) and $\text{Lu}_2\text{Si}_2\text{O}_7$ -Ce (LPS)) are known as effective scintillators. Therefore, most of works are devoted to investigation of impurity luminescence of these compounds that is determining factor of excellent scintillation properties. At the same time it is well-known that at low temperatures in many oxide scintillators there is observed rather effective intrinsic luminescence of self-trapped excitons (STEs). At room temperatures when intrinsic luminescence is quenched the secondary electronic excitations transfer energy to emission centers efficiently. The presence of this emission is an indication of lattice capability to transformation of initial excitation energy. The existence of effective channel of energy transfer as well specific structure of STE in oxides unlike to alkali halide crystals may facilitate well-known radiation stability of oxides. The present work is devoted to comparative investigation of intrinsic STE luminescence in LPS and LSO crystals differ in heavy and light cation surroundings.

LPS:Ce crystals (0.05 at. % Ce) were produced at Institute for Scintillation Materials (Kharkiv, Ukraine) and LSO crystals (0.5 mol % of Ce) grown by Melcher (USA). We used equipment of SUPRLUMI- and BW3-channels of DORIS synchrotron (HASYLAB, DESY, Hamburg) for time-resolved luminescence analysis at the selective excitation in VUV (5-30 eV) and soft X-Ray (45-250 eV) energy regions.

Wide band of UV-luminescence (FWHM=0.8 eV) at 4.5-6 eV in LPS is located at region of intrinsic emission in silicates. The origin of this luminescence was identified during study the peculiarities of its excitation near to fundamental absorption edge. Temperature quenching of intrinsic emission is observed at 100-200 K, and it is the temperature region that typical for quenching of self-trapped excitons emission in oxide crystals. As opposed to LSO crystal the STE luminescence in LPS is presented by a single band. This fact is in a good agreement with the presence of single position of lanthanide cations in LPS lattice. The decay time of luminescence at 4.5-6 eV in LPS

crystals is presented by two components with decay constants $\tau_1 < 1$ ns and $\tau_2 \approx 20$ ns (Fig. 3). The similar decay time of self-trapped excitons emission at 4.6 eV was observed early for LSO crystal. The special interest of present work is discussion of the participation of both cation sublattices in the self-trapping processes in LSO and LPS.

THE MICROCENTER HEAT EXPLOSION MODEL MODERNIZATION

**A. V. Kalenskii, V. G. Kriger, A. A. Zvekov¹, E. A. Grishaeva,
I. Yu. Zykov, A. P. Nikitin**

Kemerovo State University, Kemerovo, Russia, kriger@kemsu.ru

¹*Institute of coal chemistry and material science, Russia,
Zvekov@gmail.com*

The microcenter model of the energetic materials explosion initiation is based on the assumption that there are inclusions with radii about 100 nm strong absorbing laser irradiation in the sample's volume. The temperature of inclusion and in its neighborhood rises greatly during the laser pulse, which leads to a reaction zone formation. The cross section of the light absorption by the inclusion is thought to be equal its geometrical cross-section. It means that the absorption efficiency $Q_{abs} = 1$. This assumption needs to be proved because the inclusion's size is comparable with the light wave length and strong diffraction effects must take place.

For the modification of the microcenter model of the laser initiated heat explosion the dependence of absorption cross section on the inclusion's radius was made in terms of Mie theory. The efficiency of light absorption (Q_{abs}) by a r - radius spherical inclusion was calculated as a sum of infinite series of decomposition coefficients of electric and magnetic field in the scattered light wave in terms of special functions. The simulation showed that:

- The dependence of Q_{abs} on r is a curve with a maximum. Its position and amplitude are determined by the light wave length, inclusion's and matrix's material. When the radius is small the absorption efficiency tends to zero in accordance with Rayleigh law, in the area of large radii Q_{abs} tends to a steady state with oscillations.

- The absorption efficiency values are great for the materials with faint metal features.

- The light wave length decreasing leads to diminishing of the radius value at which the maximum on the curve is observed and the maximum amplitude becomes higher as a rule.

The calculated absorption efficiencies were taken into account during the calculation of the maximum temperature of the inclusions' heating by the laser pulse. The asymptotic equations describing the maximum heating temperatures' dependence on the pulse duration in case of inclusions' ensemble were derived. It was shown that the accounting of calculated absorption efficiency leads to a strongly pronounced maximum on the curve. The kinetics of inclusions' heating in the energetic materials volume was simulated and the conditions of explosion initiation were obtained. The results indicate that the optimal inclusions' sizes which initiate explosion decomposition at the lowest pulse energy density does not depend on the pulse duration (t) when it is less than a threshold value t_{th} . The threshold value of the pulse duration is determined by the inclusion's and matrix's material as well as the laser irradiation wave length.

Authors thank the Russian Foundation for Basic Research for financial support (№ 11-03-00897).

ELASTIC WAVES IN CRYSTALS WITH CHALCOPYRITE STRUCTURE

A.V.Kopytov, E.V.Antropova¹

Kemerovo State University, Kemerovo, Russia, kopytov@kemsu.ru

¹*Kemerovo State University, Kemerovo, Russia,
antropova_elen@mail.ru*

Anisotropy of propagation of elastic waves in CdGeAs₂ with chalcopyrite structure is investigated by method of the numerical solution of Christoffel's equation with use of experimental values of elastic constants at various temperatures. Special directions in this crystal are determined. There are five longitudinal normals and three acoustic axes in irreducible part of Brillouin zone. Propagation directions of pure transverse waves and characteristics of the internal conic refraction are also determined.

LUMINESCENT HIGH-DOSE DETECTORS ON THE BASIS OF CRYSTALLINE AND NANOSTRUCTURED MATERIALS**V.Kortov, S.Nikiforov, S.Zvonarev, Yu.Ustyantsev***Ural Federal University named after the first President of Russia**B.N.Yeltsin,**Ekaterinburg, Russia, vskortov@mail.ru*

At present there is an intensive development of radiation technologies employing high-dose radiation to modify material properties, sterilize medical products and to perform other industrial processes. High-dose detectors are also used in radiation monitoring of nuclear power station equipment and storages for spent nuclear fuel. In most cases measurement of radiation doses as high as several dozens or hundreds of kGy is required. The well-known physical methods (EPR, OA, calorimetry) and chemical reactions in irradiated detectors are used for high-dose measurements. Such detectors have rather narrow dose useful range and not very high measurement accuracy. Thus, high-dose luminescent detector development is an urgent issue today. At the same time significant progress in luminescent detector design for environmental and individual monitoring of ionizing radiation has been made. Commercial detectors of various types have a wide dose useful range (0,1 μ Gy-10Gy), high accuracy of dose measurement of different radiation kinds, low fading. Unfortunately, the changes of their luminescent and dosimetric properties under high-dose irradiation have been studied not completely.

This paper presents the ways of high-dose thermoluminescent (TL) detector development. Among them there is one based on new recombination centers formed in detector material under high-dose irradiation. They are responsible for ultra-high-temperature (UHT) dosimetric TL peaks. It was found that UHT (725K) TL peak was formed in LiF:Mg,Cu,P detectors with linear dose response from 50 kGy to 500 kGy. Another way is based on using for dosimetry the deep traps present in detector material. We have studied dose dependences of UHT (510K, 730K, 860K) TL peaks in TLD-500 detectors under gamma-irradiation. Thermo-photo-stimulation method (TA-OSL) can be used for decreasing detector heating temperature significantly to obtain dosimetric information from deep traps. This method has been developed successfully in recent years. Linear dose characteristic in the range of 10^{-2} - 10^4 Gy at Al₂O₃:C detector heating up to 570 K was obtained by means of this method.

One more promising way of high-dose TL radiation detector creation is connected with using of nanostructured analogues of the commercial detectors and new compounds. Nanostructured detectors possess high radiation resistance and their dose useful range is extended by 2-3 order towards higher doses. Our results as well as data from current literature of high-dose measurement by means of nanostructured $\text{Al}_2\text{O}_3\text{:C}$ detectors including irradiation by electron pulses with nanosecond duration are given.

Principal high-dose detector irradiation problems connected with the recovery under annealing of the detector initial characteristics are considered. Possibilities of multiple usages of high-dose detectors, their fading and measurement reproducibility are also discussed.

AB INITIO CALCULATIONS OF DEFECTS IN ALUMINA CRYSTALS

A. Yu. Kuznetsov, A.B. Sobolev, A. S. Makarov, M. A. Botov

*Ural Federal University named after the first President of Russia
B.N.Yeltsin, Ekaterinburg, Russia, ayukuznetsov@gmail.com*

Aluminium oxide with corundum structure (α) is important wide-gap optical material with a wide variety of technological applications. We present and discuss the results of calculations for some point and complex defects. This study is based on ab initio hybrid DFT calculations using B3LYP base exchange-correlation functional as implemented into CRYSTAL09 code. In order to understand the behaviour of the material with respect to irradiation and its optical properties, we analyzed the electronic structure, atomic geometry, charge density distribution et al. using supercells up to 250 atoms.

OPTICAL AND ELECTRONIC PROPERTIES OF POINT DEFECTS IN CALCIUM AND MAGNESIUM OXIDES**A. Yu. Kuznetsov, M. A. Botov, A. S. Makarov, A.B. Sobolev***Ural Federal University named after the first President of Russia
B.N.Yeltsin, Ekaterinburg, Russia, scibma@gmail.com*

The present paper is devoted to computational quantum-chemistry investigation of electronic structure and optical properties of point defects in cubic alkali-earth oxides such as magnesium and calcium oxides. All calculations were performed in CRYSTAL09 program by means of Hartree-Fock and the hybrid functional B3LYP methods with 40 % of HF exchange. Results as to optical absorption, charge density distribution, defect influence on band structure and density of states are presented. The results of calculations show satisfactory agreement with the available experimental data.

SPECTROSCOPIC PROPERTIES OF LiF CRYSTALS DOPED WITH W, Ti AND Fe OXIDES**L. Lisitsyna *¹, V. Korepanov², V. Lisitsyn², P. Petikar²**¹*Tomsk State University of Architecture and Building, 634003 Tomsk,
Russia*²*National Research Tomsk Polytechnic University, 634030 Tomsk,
Russia*

Time-resolved spectroscopy and infrared spectroscopy were used to investigate radiation transformation of the oxygen–hydrogen impurity in LiF crystals doped with oxides of different metals W, Ti and Fe with the absorbed dose range of $10^1 - 10^5$ Gy in the time interval of $10^{-9} - 10^{-1}$ s and in the temperature interval of 15 – 300 K.

It was found that the tested LiF crystals contain the following impurities complexes: O_2 , OH^- , $Me - nO_2^-$, $Me-nO^{2-}$, $Me-nOH^-$, where Me: W, Ti, Fe, $n=1, 2, 3...$ It was shown that the polyvalent cation is a place in lattice for gathering intrinsic lattice defects and oxygen-hydrogen impurities. This leads to formation of nanodefects, the size, the symmetry and characteristic zone

structure of which depend on condition of crystal growing and the valency, charge and magnetic states of the co-activator.

The structure of the nanodefekt defines both the oxygen–hydrogen impurity transformation and the processes of accumulation of the intrinsic color centers in doped crystals under ionizing radiation. The obtained results have been interpreted within hydrogen bond concept in according to which the type of the cation co-activator defines the size and the stability of hydrogen bond hole centers ($\text{Me-O}^-\text{H}^+ n\text{Hal}_2^-$, where: Hal_2^- is the center complementary to the F center) and therefore, the yield of the intrinsic electron color centers in crystals.

FIRST-PRINCIPLES MODELING OF THE SELF-TRAPPED EXCITON NONRADIATIVE DECAY IN ALKALI HALIDES

A. S. Makarov, A. Yu. Kuznetsov, A.B. Sobolev, M. A. Botov

*Ural Federal University named after the first President of Russia
B.N.Yeltsin, Ekaterinburg, Russia, ayukuznetsov@gmail.com*

We present the results of quantum mechanical investigation of triplet off-center STE in alkali halide crystals. Calculations were performed in CRYSTAL09 program package in terms of hybrid functional. An equilibrium configuration of defects under modeling was obtained with taking into account supercell total relaxation. Properties of defects were discussed on the basis of data relevant to spatial structure, charge distribution and density of electronic states. Nonradiative decay of STE in alkali halide crystals was considered. Configuration curves of this process were calculated and F-H pair forming was analyzed. Results relating to energy characteristics of process mentioned above are presented.

ON THE QUESTION OF VARIETY OF RE IONS LOCAL ENVIRONMENTS IN OXIDE GLASSES**E. Malchukova^{1*}, A. Nepomnyaschich² and B. Boizot³**

¹ *Ioffe Physical Technical Institute, Saint-Petersburg, Russiae-mail: evguenia.malchukova@polytechnique.edu*

² *Geochemistry Institute, Irkutsk, Russia*

³ *Laboratoire des Solides Irradiés, UMR 7642 CEA-CNRS-Ecole Polytechnique, Palaiseau, France*

Doping of glasses with various fluorescent ions and the investigation of their interaction with the glass-matrix by static fluorescence emission and excitation spectra is a widely used tool in glass structure research. Time-resolved fluorescence measurements can offer additional information on local microstructure of the doped ions as well as information on the glass-matrix itself.

In this study fluorescence lifetime dependency on doping RE concentration and EPR spectra were investigated. For this reason pristine and β -irradiated (10^9 Gy) aluminoborosilicate glasses with known properties and global structure have been used as host materials. Different RE ions (Sm, Eu, Ce and Gd) were embedded into the ABS matrix in order to study their influence on glass structure modifications and changes in luminescence ability.

By the combination of two spectroscopic techniques (EPR and luminescence), it has been shown the presence of more than one RE site in these glasses characterized by different crystal field strength and covalency that is confirmed by lifetime measurements. It is found that exposure to β -irradiation doesn't create the new RE positions in the glass but allows a change in covalence of the doped ion's surrounding. The relative proportion between sites depends strongly on the RE reduction processes in ABS glass during the high-temperature melting in air and β -irradiation.

RADIOLYSIS OF ALKALI-EARTH NITRATES

M. B. Miklin¹, L. D. Kriger¹, S.Yu. Lyrshikov²

¹*Kemerovo state university, Kemerovo, Russia, miklin@kemsu.ru*

²*Institute of coal chemistry and material science SB RAS, Kemerovo, Russia, serstud@mail.ru*

The radiation induced decomposition of alkaline earth nitrates has been studied at room temperature. The changes in IR and UV spectra of nitrates due to irradiation are described. The yield of peroxyxynitrite in the decomposition by γ -rays of the alkaline earth nitrates has been measured. In the optical absorption spectra of nitrates were found in two radiation-induced absorption bands, one in the 245-270 nm and the other in the 320-370 nm region. Presumably the first band attributed to the absorption of the radical O_2^- , and the second to the absorption of nitrite ions. IR spectra showed the presence of a single band at $\sim 1250\text{ cm}^{-1}$ due to ν_3 vibration of nitrite ion. During thermal annealing of irradiated barium nitrate bands at 1250 cm^{-1} and 350 nm annealed at the same time, which confirms the identification of bands.

COPPER IMPURITY IN LiF AND NaF CRYSTALS FROM AB INITIO CALCULATION: STRUCTURE AND OPTICAL PROPERTIES

A.Myasnikova, A.Mysovsky, A.Paklin and A.Shalaev

Vinogradov Institute of Geochemistry SB RAS, Irkutsk, Russia, sasham@igc.irk.ru

The interest to study of the copper impurity embedded in LiF crystal is due to using of LiF:Mg,Cu,P detectors for thermoluminescent dosimetry [1]. It is known that the storage of ionising radiation energy in the detectors is connected with radiation transformation of magnesium centres similar to that in LiF: Mg, Ti. However the role of copper impurity in the thermostimulated luminescence processes is significant and not completely clear yet. Therefore the study of LiF and NaF doped with copper ion in different charge states (Cu^0 , Cu^+ and Cu^{++}) still remains actual problem.

In this work we present the results of an ab initio calculations of electronic and spatial structure of copper impurity as well as $3d^{10} \rightarrow 3d^9 4s^1$ ab-

sorption and relevant emission. We used several clusters of cubic symmetry for the calculations. All our results were obtained with taking into account the lattice relaxation in the presence of copper impurity ion. The ab initio calculations have been performed in embedded-cluster approach implemented in the GUESS computer code [2]. In this work the electronic structure of QM cluster has been calculated in DFT method with using modified B3LYP functional (40% of Hartree-Fock ex-change and 60% of DFT exchange). Time-dependent DFT (TD DFT) method was applied for calculation of transition energies. The Gaussian 03 [3] computer code was used for excited state calculations.

According to the data obtained only on-centre configuration of ground state of copper ion was observed. Calculated energies of optical absorption and luminescence are in satisfactory agreements with experimental data. Energies of optical absorption of monovalent copper ion in LiF agree well with our recent experimental data [4]. The model and configuration of excited state will be discussed.

This work was partially supported by Federal Target Program "Scientific and scientific-pedagogical personnel of innovative Russia" in 2009-2013 (GK P1243).

[1] Horowitz A., Horowitz Y.S. *Radiation Prot. Dosimetry* 33 267 (1990)

[2] P.V. Sushko, *Surface Science*. 450 153 (2000)

[3] Frisch M.J., Trucks G.W., Schlegel H.B. et al. *Gaussian 03* (Revision E.1). – Gaussian Inc., Pittsburgh PA, 2007.

[4] A I Nepomnyashchikh, A A Shalaev, A K Subanakov, A S Paklin, N S Bobina, A S Myasnikova and R Shendrik. 2010, *IOP Conference Series: Materials Science and Engineering* 15 012043

**THE MODELING OF INTRINSIC LUMINECSENCE IGNITION
EFFECT IN CRYSTAL KI AT LOW TEMPERATURE
ELASTIK STRESS**

**L.N. Myasnikova, N. N. Zhanturina¹, K. Sh. Shunkeyev, B.A.
Aliev¹, M. Grinberg², V.S. Tkachenko**

*Aktobe State Pedagogical Institute, Aktobe, Kazakhstan,
myasnikova_ln@mail.ru*

¹*Al-Farabi Kazakh National University, Almaty, Kazakhstan*

²*University of Gdansk, Gdansk, Poland*

The dynamics of excitons self-trapping in alkali halide crystals (AHC) is highly dependent on changes in the interionic distances by uniaxial and hydrostatic deformation, and it provides a more valuable information about the optical characteristics. Intrinsic luminescence quenching effects in AHC with increasing temperature from 4.2 K to 80 K, and the luminescence intensity increase at the uniaxial stress were observed previously [1]. We were able to explain these effects through the dynamics of the self-trapping excitons potential barrier with the simultaneous influence of the temperature and the uniaxial compression and by the activation energy between the radiation and irradiation channels of excitons annihilation.

We did a detailed explanation of the phenomenon that the self-trapping potential barrier (STB) between the quasifree and self-trapped exciton (STE) states decreases with temperature increasing by introducing the concept of induced by phonons fluctuation potential.

By the continuum model we obtain the dependence of STB height on the temperature and the degree of stress.

In the crystal KI STB height decreases with simultaneous increase of temperature and stress. Height decreasing of excitons self-trapping potential barrier is confirmed with the experimental fact of the luminescence quenching at temperature increase and the comparative prevalence of non-radiative annihilation channel.

The experimental method for the determination of the activation energy between channels of radiative and non-radiative annihilation of STE in alkali halide crystals was worked out. The principle of method lies in the registration the temperature dependence of STE' luminescence with and without the influence of low temperature uniaxial elastic stress.

– The activation energy ($\Delta\varepsilon$) of temperature luminescence quenching of self-trapped excitons was determined in crystals: KI (π -37 meV; σ -33.7 meV). The energy values reflect the potential barrier channels of STE.

– The output increase of the crystals' intrinsic luminescence is explained by the potential separating radiative and non-radiative decay barrier's growth. The potential barrier decreases the probability of radiative defect creation at the STE decay.

[1] A.Z. Bekeshev, E.A. Vasil'chenko, E.T. Sarmukhanov, K.Sh. Shunkeev and A.A. Elango. X-ray and photoluminescence in mechanically stressed KCl, KBr, and KI crystals//Phys. Sol. State. V.36, N.2, 1994. P.180-185.

GROWTH AND OPTICAL CHARACTERIZATION OF COPPER-DOPED LITHIUM FLUORIDE SINGLE CRYSTALS

A. Nepomnyashchikh^{1,2}, A. Shalaev^{1,2}, A. Paklin¹, R. Shendrik^{1,2}, N.Bobina¹ and A. Myasnikova¹

¹*Vinogradov Institute of Geochemistry SB RAS, Irkutsk, Russia,
e-mail:alshal@igc.irk.ru*

²*Irkutsk State University, Faculty of Physics, Irkutsk, Russia*

Lithium fluoride is a widely used in solid state dosimetry. It is expected that single crystals of LiF with monovalent copper impurity will be a new matrix for efficient tissue-equivalent detector LiF:Mg,Cu. It is supposed that light yield of this detector will be larger than existent thermoluminescence detectors. The greater light yield is assumed to be due to direct recombination mechanism with monovalent copper ions. But the growth of LiF:Cu⁺ single crystals is difficult because of a copper instability in monovalent state. Copper monovalent ions actively reduce to metal or oxidized to two-valent state. Some of features of LiF:Cu⁺ single crystal growth and spectroscopy results are described.

Before crystal growth to stabilize monovalent copper in lithium fluoride we synthesized the mixture by solid state reactions. Cu-doped LiF mixtures were prepared by mixing LiF with various amounts of CuCl. Chemical composition of mixtures and crystals were determined by atomic absorption spectrometry method. Copper content in crystals was 0,0004-0,002%.

Cu-doped LiF crystals have been grown by Czochralski method. Resistive nichrome heater and metal elements of thermal screens were used to avoid reduction of monovalent copper. The sintered powder was charged in a platinum crucible. Crystallization was made in argon atmosphere. The melting point of LiF is at about 870°C. A rate of single crystal growth was at about 5 mm/hour. Crystal structure like NaCl and cuts is generally in $\langle 100 \rangle$ plane and least often $\langle 110 \rangle$ plane.

Emission and excitation spectra were measured in our samples. A Perkin-Elmer Lambda 950 spectrophotometer and a Perkin-Elmer LS55 fluorimeter were used. Emission peak at 350 nm and excitation peak at 275 nm in our LiF:Cu crystals are attributable to Cu^+ impurities. In absorption spectrum a band at 280 nm was found. The band at 280 nm could be corresponded to Cu^+ centers [1].

This work was performed under Federal Target Program "Scientific and scientific-pedagogical personnel of innovative Russia" in 2009-2013 (GK P1243).

[1] J. Simonetti and D. S. McClure Phys. Rev. B 169 3887 (1977)

GENERAL INTERACTIVE TRAP SYSTEM MODEL FOR THERMOLUMINESCENCE OF $\text{Al}_2\text{O}_3\text{:C}$ SINGLE CRYSTALS

S.V. Nikiforov, V.S. Kortov

*Ural Federal University, Ekaterinburg, Russian Federation,
s.v.nikiforov@ustu.ru*

Great interest in study of thermoluminescence (TL) properties in $\text{Al}_2\text{O}_3\text{:C}$ single crystals is caused by their wide use in ionizing radiation dosimetry. Several kinetic models have been designed to describe TL mechanism in these crystals. General interactive trap system model taking into account competing temperature-dependent capture of the carriers on deep electron traps while detecting TL dosimetric peak at 450 K was offered in our paper [1]. Later on this model was extended to include consideration of the processes with hole deep center participation [2]. However, the abovementioned models failed to include a number of TL properties in the crystals under study. In particular, the fact that dosimetric TL peak has different half-width and is caused by superposition of several different in nature traps was

not taken into account. Moreover, shallow traps responsible for TL peak at 360 K in the crystals under study were not the subject of consideration.

The aim of this paper is to extend and summarize model assumptions describing TL mechanisms in $\text{Al}_2\text{O}_3:\text{C}$ single crystals.

The suggested kinetic TL model takes into account the following localized levels corresponding to various defect types in the crystals under study: dosimetric traps, deep electron traps, deep hole trapping centers, shallow traps, and luminescence center (F-center). The model assumes that dosimetric peak is caused by superposition of electron and hole traps with similar values of activation energy. While being thermally activated, electrons and holes captured by active dosimetric traps are injected into conduction and valence bands correspondingly. The excited states of both electrons and holes can be relaxed due to a number of processes: radiative recombination on the luminescence center; electron capture by the deep trap; charge carrier re-capture by TL-active trap; nonradiative recombination of electrons and holes in the deep hole trap. Moreover, shallow traps in which dosimetric traps serve as deep centers can be engaged in such processes.

Using the developed model the calculations of TL characteristics in the crystals under study were carried out. It was shown that the model accounts for dosimetric peak half-width variation as well as experimentally found features of deep trap influence on radiation sensitivity and its dependence on heating rate, and on non-linearity of dose dependence. Furthermore, the model accounts for dosimetric TL peak parameter correlation and that of peak at 360 K resulting from shallow traps. The paper also provides the discussion of the trap nature responsible for TL peak broadening at 450 K. The obtained results allow one to presume interactive mechanism universality of various trap types interaction in dosimetric crystals $\text{Al}_2\text{O}_3:\text{C}$.

[1] I.I. Milman, V.S. Kortov, and S.V. Nikiforov. *Radiat. Meas.* 29, 401 (1998).

[2] S.V. Nikiforov and V.S. Kortov. *Radiat. Meas.* 45, 527 (2010).

**RECOMBINATIONAL AND RADIOSTIMULATED PROCESSES
IN SULPHATES WITH CORRELATED DEFECTS**

**T.N. Nurakhmetov, A.Kainarbay, D.M.Salikhodja, A.Zhunusbekov,
Sadykova B.M., Pazylbek C., Karipbayev Zh.T.**

*L.N.Gumilyov Eurasian national university, Astana, St. Republic
of Kazakhstan,
E-mail: Nurahmetov_T@enu.kz*

Energy levels of the electronic and hole captures centre are located approximately at one level a relatively to valence bond top and a bottom of conductivity bond in irradiated ionic crystals at low temperature. Increase of concentration and accumulation process of the electron-hole capture centers (considering return recombination) negligible changes energy distance between captures centre in E_g of a matrix. In complex ionic crystals having tetrahedron anion, in particular, in sulphates of alkaline and alkaline earth metals, electron and the holes, which localized in tetrahedron anion SO_4^{2-} , can localize in different nonequivalent crystallographic directions from each other. Local energy levels, corresponding to them, should be in the various.

On the basis of the experimental facts probably to predict a existence of the correlated elektron-hole capture centres in the irradiated sulphates of alkaline metals. Such kind the centres are on various energy distances apart from a bottom of conductivity bond and valence bond top, accordingly. If in the irradiated crystals to create such energy state, emission band of various energy in certain spectral intervals should be observed at recombination.

In x-ray irradiated at 80 K crystals of $LiKSO_4$, Li_2SO_4 and Na_2SO_4 observed wide band of recombination emission which consisting of several maxima by us.

In X-ray luminescence spectra, phosphorescence spectrum and in spectral distribution of basic peaks TSL it is observed one same bands with several maxima.

We discuss the nature of these bands, their connect with the correlated defects of a lattice.

A PULSED OPTICAL CHARACTERIZATION OF OPTICAL CRYSTALS WITH MOBILE CATIONS

I. N. Ogorodnikov, M. S. Kiseleva, V. Yu. Yakovlev¹

*Ural Federal University, Yekaterinburg, Russia,
i.n.ogorodnikov@gmail.com*

¹ *Tomsk Polytechnic University, Tomsk, Russia*

In present paper we investigated the kinetics of electron tunneling under conditions of the thermally stimulated mobility of recombination partners for optical crystals of lithium borates and potassium and ammonium dihydrophosphates by means of both the time-resolved optical absorption spectroscopy and mathematical modeling. We developed a mathematical model and carried out the numerical simulation. Comparison of the calculated and experimental data on transient optical absorption (TOA) of these crystals in the visible and ultraviolet spectral regions allowed us formulate the following conclusions.

Pulsed radiation exposure leads to the formation the polaron type hole centers in the form of O^- center and the trapped electron centers (interstitial Li^0 or H^0 atoms). TOA occurs due to optical transitions between the valence band states and the local levels of the trapped hole centers.

The model of the electron tunneling between the trapped electron and hole centers under conditions of the thermally stimulated mobility of one of the partners of the recombination process describes adequately all the features of the TOA kinetics observed after pulsed exposure of radiation in the crystals over the broad decay-time region of 10 ns -100 s.

Decay kinetics of the TOA consists of two characteristic regions. The initial part of the process is controlled by electron tunneling and its approximation can be done by the tunneling recombination law for the frozen system of defects. The ultimate part of the decay kinetics is controlled mainly by the diffusion process and it results in the rapid hyperbolic decay of intensity. With increasing temperature, the hyperbolic plot is shifted to shorter decay times. Thermally stimulated 'shortening' of the decay kinetics is characterized by an activation energy corresponding to the diffusion-controlled process.

The complex behavior of the reaction rate $K(t)$ throughout the observed region of decay times indicates the presence of transient diffusion-controlled tunnel recharging of the defects. In this case we are dealing with transitional

decay kinetics and simple asymptotic formula (for example, the law of Becquerel) can not be used to describe such kinetics.

With increasing temperature, there is an increase of the initial defect concentration n_0 , created by the excitation pulse of constant intensity. Temperature dependence of the negative slope in the initial part of the TOA decay kinetics on log-log scale is characterized by an activation energy corresponding to the diffusion controlling the accumulation of defects during the exciting pulse.

A LUMINESCENCE SPECTROSCOPY STUDY OF NON-LINEAR OPTICAL CRYSTALS $K_2Al_2B_2O_7$

**I. N. Ogorodnikov, V. A. Pustovarov, S. A. Yakovlev, L. I. Isaenko¹,
S. A. Zhurkov¹**

*Ural Federal University, Yekaterinburg, Russia,
i.n.ogorodnikov@gmail.com*

¹ *Institute of Geology and Mineralogy, SB RAS, Novosibirsk, Russia*

Optical low-symmetry crystals are widely used in nonlinear and integrated optics, laser technology, as well as in detectors and transformers of ionizing radiation. These crystals are studied intensively in recent years, both in terms of fundamental properties, and in terms of their practical applications as optical materials operating in the ultraviolet (UV) and vacuum ultraviolet (VUV) spectral regions. In this respect, $K_2Al_2B_2O_7$ (KABO) crystals represent a relatively new nonlinear-optical material developed for application in a wide spectral range from 180 to 3600 nm.

In this work we have carried out the first study of the KABO crystals using low-temperature luminescence-optical vacuum ultraviolet spectroscopy with nanosecond time resolution. Based on the set of experimental data obtained for the first time on the photoluminescence decay kinetics, PL spectra with time resolution, PL excitation spectra with time resolution, and reflection spectra at 7 K, the bandgap width was estimated as $E_g = 7.8-8.2$ eV; the intrinsic nature of PL at 3.28 eV (band II) was established, defect luminescence bands at 2.68 eV (band I) and at 3.54 eV (band III) were separated. Along with this, we measured the KABO optical spectra in the spectral range of 180 -1000 nm. Three absorption peaks at 4.7, 5.8 and 6.5 eV were detected and assigned to charge-transfer absorption from O^{2-} to Fe^{3+} ions. The chan-

nels of the formation and decay of electronic excitations in KABO crystals and the luminescence center nature were discussed. According to the developed concepts, PL band II (3.28 eV) is caused by intrinsic luminescence of the KABO crystal and is presumably attributed to radiative annihilation of self-trapped excitons. The strong long-wavelength PL band at 1.72 eV was detected and attributed to a radiative transition ${}^4T_1 \rightarrow {}^6A_1$ in Fe^{3+} ion. Defect luminescence bands in the visible and ultraviolet spectral region are presumably attributed to radiative transitions in defect complexes consisting of Fe^{3+} ion and lattice defects in various environments of the KABO lattice.

SPECTRAL AND KINETIC CHARACTERISTICS OF LUMINESCENCE OF AlGaN/InGaN/GaN HETEROSTRUCTURES EXCITED BY HIGH-CURRENT ELECTRON BEAM

V. I. Oleshko, S. G. Gorina, V. I. Korepanov, V. M. Lisitsyn

*National Research Tomsk Polytechnic University, Tomsk, Russia,
oleshko@tpu.ru*

Group III-V nitrides are the most promising materials for fabricating light- and laser diodes in the visible and UV region. However, their benefits realization is constrained by the major difficulties of the production of high quality epitaxial layers of these materials. Intrinsic defects of the crystal lattice, uncontrollable impurities and dislocations formed in the epitaxial layers during the growth are responsible for the optical properties and the lifetime of LEDs. Luminescent methods allow monitoring of intrinsic and extrinsic defects presence in epitaxial layers and determining of structures suitability for light sources manufacture.

The purpose of this paper is to study the mechanism of radiative recombination of AlGaN/InGaN/GaN heterostructures. As the investigated materials were used AlGaN/InGaN/GaN LED heterostructures with InGaN/GaN-quantum wells grown in different laboratories by metalorganic vapor-phase epitaxy on sapphire [0001] substrates. The samples were excited by high-current electron beam (HCEB) and pulsed nitrogen laser ($\lambda = 337.1$ nm).

It was found out that at low HCEB energy density ($H \leq 0.04$ J/sm²) the cathodoluminescence (CL) spectrum of samples consists of two bands, which maxima correspond to the energies 3.35—3.37 eV and 2.80—2.82 eV. UV band (3.35—3.37 eV) belongs to GaN and is caused by recombination of

bound to defects excitons. Spectral and kinetic characteristics of the blue CL band (2.80—2.82 eV) allow to suppose that one is due to the recombination of donor-acceptor pairs formed in InGaN-quantum well during the growth. This supposition is confirmed by the spectral-kinetic characteristics of blue luminescence band obtained under laser excitation. The blue band maximum shifts to shorter wavelengths with increasing excitation level, and one shifts to longer wavelengths with increasing time delay.

The influence of HCEB energy density H on the spectral-kinetic characteristics and intensity of CL of LED structures was studied. It was found out that a narrow emission line with a peak at $h\nu = 2.78$ eV stands out against a background of the broad blue band when H runs to its threshold value (for one of the samples). With H increasing the ultralinear increase of this line intensity and the decrease of pulse emission duration are observed. This is indicative of the transition from spontaneous luminescence to stimulated emission mode.

The results allow concluding the possibility of developing economical and rapid method of LED epitaxial layers control under HCEB excitation.

LUMINESCENCE OF ZINC SELENIDE CRYSTALS EXCITED BY ELECTRON BEAM PULSE

V.I. Oleshko, S.S. Vil'chinskaya, A.I. Kupchishin, S.G. Gorina

*National Research Tomsk Polytechnic University, Tomsk, Russia,
svetvil@tpu.ru*

The spectral and kinetic characteristics of pulse cathodoluminescence of undoped ZnSe single-crystals grown by sublimation from the vapor phase (Davydov-Markov method) and by flux growth (Bridgman method) have been measured. Three groups of bands were found in the spectra of radiative recombination of zinc selenide: exciton, edge emission and bands due to the recombination of carriers in deep centers. The spectral-kinetic characteristics of the edge emission in ZnSe crystals with different previous history have been studied. It was found that the number of edge emission series, the ratio of their intensities and spectral position are to be determined by the previous history of crystals. It is shown that the total intensity of the edge emission reduces more than tenfold with the temperature increase in the range of 15 - 80 K. The results obtained show that the properties of the edge emission can

be well described by the model of donor-acceptor pairs.

SCINTILLATION RESPONSE OF CsI(WO₄) TO IRRADIATION

**N.V. Ovcharenko, V.Yu. Yakovlev¹, Yu.S. Ganja¹, L.N. Trefilova²,
O.V. Zelenskaya², T.P.Rebrova², O. V. Gayduk³, D. S. Sofronov⁴**

*Institute for Scintillation Materials of NASU, Kharkov, Ukraine,
ovcharenko@isma.kharkov.ua*

¹*Tomsk Polytechnic University, Tomsk, Russia, yak999@rambler.ru*

²*Institute for Scintillation Materials, Kharkov, Ukraine,
shpil@isc.kharkov.com*

³*Institute for Single Crystals of NASU, Kharkov, Ukraine,
gayduk@isc.kharkov.com*

⁴*STC "Institute for single crystals" of NASU, Kharkov, Ukraine,
sofronov@isc.kharkov.com*

CsI crystals doped with cesium tungstate Cs₂WO₄ have responded to electron pulse irradiation with an emission at about 415 nm only within this temperature range 200-420 K. The concentration of tungsten W in the crystals has been evaluated by chemical analysis, and the concentration of WO₄²⁻ ions by absorption coefficient for their ν₃- vibration bands at 820 and 860 cm⁻¹. It has been found that the intensity of this emission is directly proportional to the absorption coefficient for the vibration bands of WO₄²⁻ ions. The pulse of this emission rises exponentially and decays hyperbolically in microsecond time scale.

A well pronounced band at 708 nm has been detected in the transient absorption spectra of CsI:WO₄. It has been observed that 415 nm emission band and 708 nm absorption band decay simultaneously. Having an excessive negative charge, WO₄²⁻ ions form dipoles with anionic vacancies, neutralizing the crystal charge. Therefore the band at 708 nm can be attributed to F_A centers that is, F-centers under perturbation of WO₄²⁻ ions. Thus, it is safe to assume an electron, tunneling in short interspace pairs {F_A, V_k} from F_A to V_k results in a localized exciton which is responsible to the emission at 415 nm.

As for the light yield of CsI:WO₄ crystals, it is twice lower than that of CsI:3.1·10⁻² mol%Na. The emission of CsI:WO₄ decays hyperbolically like the emission of CsI:Na with a low activator concentration (2.2·10⁻

³ mol%Na), while the emission of CsI:Na with a high activator concentration ($3.1 \cdot 10^{-2}$ mol%Na) decays exponentially. The hyperbolic kinetics is the evidence of a low concentration of WO_4^{2-} ions in the crystal, in spite of a high concentration of tungsten ($5.1 \cdot 10^{-1}$ mol%W). Such an incongruity can be explained by the conversion of the majority of cesium tungstate into tungsten oxide which we think is a quenching center. To prove this idea we have doped CsI with WO_3 and found that it does not respond with activator emission to irradiation.

LUMINESCENT PROPERTIES OF NEW ORGANIC LUMINOPHORES

M. D. Petrenko, D. S. Kopchuk, I. S. Kovalev, I. N. Ogorodnikov, D. V. Raykov, G. V. Zyryanov

Ural Federal University, Yekaterinburg, Russia, maxx1088@gmail.com

The development of new detectors and sensor elements requires a preliminary study of the fundamental properties of materials used in these devices. In this regard, organic phosphors and scintillators are promising materials that have attracted particular attention. In this paper we present the results of research on optical and luminescent properties of some organic compounds based on pyrene. The main purpose of this paper is to obtain information about the optical properties and energy transfer processes in the studied materials.

We investigated two different pyrene containing compounds:

2,3,7,8-bis-(9H,10H- anthracene -9,10-diyl)-1,6 -dibromopyrene;

2,3,7,8-bis(9H,10H- anthracene -9,10-diyl)-1,6-di(5-nonyloxythiophene-2-yl)pyrene.

All the samples were synthesized at the Chemical-Technological Institute of Ural Federal University. Optical and luminescent properties of the samples were studied at the Experimental Physics Department of Ural Federal University.

For these samples we have studied in the visible and UV spectral region, the photoluminescence (PL) spectra, the PL excitation (PLE) spectra, and the optical absorption spectra. Characteristic bands of compounds were detected in the PL and PLE spectra. We have studied the dependence of the intensity

of PL and PL spectra on the experimental conditions and concentrations of various impurities.

On the basis of the obtained results we discuss the origin of the luminescence centers and the mechanisms of the energy transfers in these compounds. The results suggest further study of this promising class of organic compounds. The synthesis of new organic compounds and these properties research is planned in future. It will provide new opportunities in sensor devices development by using the examined organic materials.

5D-4F LUMINESCENCE OF ND³⁺, ER³⁺ AND TM³⁺ IONS WITH SEVERAL CONCENTRATION IN FLUORIDES

E.A. Prosekina, E.A. Radzhabov

*Vinogradov Institute of Geochemistry SB RAS, Russia, Irkutsk,
eea1982@mail.ru*

The emission from the 5d to the 4f levels are intensively studied in recent decades [1-3]. For most of the ions the emission was observed in the vacuum ultraviolet and may be used for the development of laser media.

The aim of this paper is to compare the luminescence spectra of RE-ions-doped alkaline-earth fluorides at different concentrations.

We investigate the emission spectra of crystals of BaF₂, SaF₂, SrF₂, doped by RE-ions. Crystals were doped by erbium (Er³⁺), neodymium (Nd³⁺) or thulium (Tm³⁺) in concentration ranging from 0.01 to 10 mol.%. Samples were excited by Xe resonance lamp. Emission was measured by a FEU 142 or FEU39A photomultipliers mounted on a VM4 grating vacuum monochromator.

Emission from the 5d to 4f shell of rare earth ions was observed. With increasing impurity concentration the shift of the 5d-4f transition band to the long-wavelength region in spectra was observed (Fig. 1). Also, we observed a decrease in the intensity of the 5d-4f bands with increasing of impurity concentration. When the concentration of impurity was 3-10% the vacuum ultraviolet emission was not observed. With increasing impurity concentration to 1% there are new bands in some spectra.

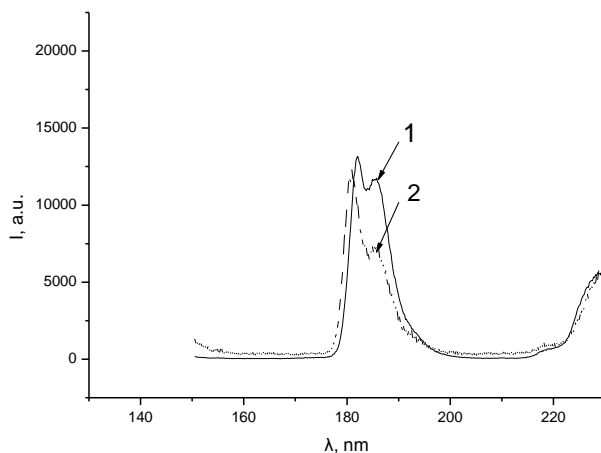

Fig.1. Emission spectra BaF₂-NdF₃. 1- BaF₂-0.3%NdF₃,
2- BaF₂-0.01%NdF₃ (increased by 9 times).

- [1]. R.T.Wegh, A.Meijerink, Physical Review B, 1999, Vol. 60, № 15, p.10820.
[2]. Marjorie Mujaji, J.D.Comins, Physical Review B, 1999, Vol. 59, № 9.
[3]. Stryganyuk G., Zimmerer G. // ФТТ. 2008. Т. 50. С.1570.

**QUANTUM-CHEMICAL MODELING OF RADIATION
DEFECTS FORMATION PROCESSES IN CRYSTALS
LiKSO₄, LiNaSO₄, CaSO₄**

**Zh.M. Salikhoja, T.N. Nurakhmetov, A.Zh. Kainarbai, B.M. Sadykova,
D. Mussakhanov, A. Dzhunusbekov, A. Agibetova**

*L.N.Gumilyov Eurasian National University, Astana, Kazakhstan,
s_jus64@mail.ru*

Processes of defect formation in the irradiated sulfate of alkaline metals and alkaline earth metals are connected generally by disintegration of an anionic complex with difficult structure. SO_4^- , SO_3^{2-} , SO_3^- and O^- , O_3^- centers are discovered by experimental methods, which are the end products of the processes of formation of radiation defects. Radiation of these crystals X-ray, γ - and ultraviolet radiations lead to creation of the same defects of a crystal lat-

tice, i.e. the process of defect formation in sulfates is carried out by low energy mechanisms. In literature two main mechanisms of creation of defects are discussed. According to the first mechanism of a SO_4^- hole centre can self trapped in the form of the radical, and the electron is grasped in the next anionic complex via reaction $SO_4^{2-} + e^- \rightarrow SO_4^{3-}$. In this process the correlated pairs of defects are created: $SO_4^- \dots SO_4^{3-}$. The localized holes SO_4^- in sulfates are thermally stable to temperatures 340-350 K, and the electron-superfluous centers SO_4^{3-} are stable only at low temperatures. In secondary processes electronic and superfluous complexes $SO_3^{2-}O^-$, can be transformed to stable defects. The electronic SO_4^{3-} and SO_4^- -hole trap centers are in any case created.

At realization of the second mechanism the excited anionic excitons during a relaxation can break up with formation of Frenkel's pairs of defects via reaction $(SO_4^{2-})^* \rightarrow SO_3^-v_0^+e^- + O^0$, where $SO_3^-v_0^+e^-$ - the electronic centers. The interstitial atom of oxygen as the hole center can be stabilized as the O_3^- -center. Mechanisms of formation of these centers are not studied completely. In recent years, to examine the processes of formation of defects in ionic crystals are widely used in quantum chemical methods by the semi empirical methods of modeling.

We have modeled processes of formation of SO_4^- , SO_3^{2-} , SO_3^- and O^- , O_3^- -centers in crystals of $LiKSO_4$, $LiNaSO_4$, $CaSO_4$ using quantum-chemical methods. For this purpose models of these crystals are constructed. The $LiKSO_4$ model consists of 8 cations of Li +, 8 cations of K +, 8 anionic complexes SO_4^{2-} , and $LiNaSO_4$ consists of 12 cations of Li +, 12 cations of Na + and 12 anionic complexes SO_4^{2-} . The model of a crystal of $CaSO_4$ consists of 6 elementary cells. Modeling of processes of formation of radiating defects in crystals is carried out in singlet and triplet states. On the basis of quantum and chemical calculations energy of formation of radiation defects are defined and mechanisms of their formation are offered.

**ENERGY TRANSFER PROCESSES IN $\text{Li}_6(\text{Gd},\text{Eu},\text{Y})(\text{BO}_3)_3$
BULK CRYSTALS AND FIBERS**

I. N. Sedunova, I. N. Ogorodnikov, V. Yu. Ivanov, V. A. Pustovarov

*Ural Federal University, Yekaterinburg, Russia,
i.n.sedunova@gmail.com*

Gadolinium-based crystals doped with rare earth elements are excellent scintillators for ionizing radiation detection. These crystals are characterized by bright and fast scintillation that depends on activator content. Lithium lanthanide borates $\text{Li}_6(\text{Gd},\text{Y})(\text{BO}_3)_3$ are related to this class of scintillators and considered as promising material for thermal neutron detection[1,2]. The fibers based on such material have better scintillation characteristics (due to decreasing the light loss) and technological advantages (flexibility, probability of detector geometry optimization, etc.). The purpose of the present research is to study the elementary processes of energy transfer in gadolinium-based borate crystals and fibers. The special attention is given to thermally stimulated recombination processes that explain dynamics of electron excitations in crystals.

$\text{Li}_6(\text{Gd},\text{Y})(\text{BO}_3)_3$ bulk crystals were grown by Czochralski method at the Institute of Geology and Mineralogy of SB RAS (Novosibirsk) and at the State Scientific Institution «Institute for Single Crystals» of NAS (Kharkiv, Ukraine). $\text{Li}_6(\text{Gd},\text{Y})(\text{BO}_3)_3$ fibers were produced using micro pulling down method at Université Lyon 1 (Lyon, France) at argon atmosphere. We studied recombination processes in crystals at different types of excitation – photoexcitation, vacuum UV, X-Ray.

We have observed the intrinsic luminescence corresponding to ${}^6\text{P}_j \rightarrow {}^8\text{S}_{7/2}$ transitions in host Gd^{3+} ion and impurity luminescence related to transitions in activator ions (cerium, europium). The specific feature of crystal structure is the presence of Gd^{3+} ion chains extended along one direction [3]. It allows to realize effective mechanism of host-to-activator energy transfer. The correlation between intensities of intrinsic and impurity luminescence indirectly testifies to efficiency of energy transfer channel in crystals. The temperature dependences of intrinsic and impurity luminescence can also describe the recombination processes and distribution of energy in crystal. We discuss the models that explain the dynamics of electron excitations resulting in scintillation.

[1] J.B. Czirr, G.M. MacGillivray, R.R. MacGillivray et al. Nucl. Instr. and Methods in Phys. Res. A 424, 15 (1999).

[2] M.J. Knitel, P. Dorenbos, C.W.E. van Eijk et al. Nucl. Instr. and Methods in Phys. Res. A 443, 364 (2000).

[3] C.T. Garapon, B. Jacquier, J.P. Chaminade, and C. Fouassier, J. Lumin. 34, 211 (1985).

ANDREEV REFLECTION OF PSEUDO-CORRELATED PAIRS ELECTRONS IN THE SYSTEM «SUPERCONDUCTOR– FLUCTUATION SUPERCONDUCTOR–SUPERCONDUCTOR»

D. M. Sergeyev, K. Sh. Shunkeyev¹

*Military Institute of Air Defense Forces, Aktobe, Kazakhstan,
serdau@rambler.ru¹*

Aktobe State Pedagogical Institute, Aktobe, Kazakhstan

It is known that at temperatures above the T_c ($T_c < T < T^*$) the order parameter is not equal in superconductors (SC) to zero and is observed fluctuation conductivity, i.e. fluctuation superconductor (FSC). At $T=T^*$ pseudo-correlated pairs electrons (fluctuation pairs) with a coherence length $\xi_{FSC} T^*$ are formed. We believe that $\xi_{FSC} T$ similar pairs decreases with fall T and it is possible at $T=T_c$ it is transformed in Cooper pairs $\xi_{FSC} T \rightarrow \xi_{SC} T$.

In this paper we examine the possible conversion of Cooper pairs in pseudo-correlated (fluctuation) pair when crossing through interface SC-FSC, and vice versa when crossing through interface FSC-SC transformation pseudo-correlated pairs electrons in the Cooper pairs in Josephson system such as SC-FSC-SC. It is likely Andreev reflection of the weakly bound electron, which is part of the fluctuation pairs, in the interface FSC-SC, with the possible formation of a pair of «not tunneling electron - hole is reflected». Further in the 2nd interface FSC-SC is reflected hole in electron and an pseudo-correlated pairs electrons is generated. Possibly the transformation of the reflected hole in the 1st interface FSC-SC is with the formation of two correlated Cooper pairs, forming a unique cluster with charge $4e$.

Studying of possible transformation fluctuation pairs in Cooper pairs in Josephson systems FSC-SC gives the chance to understand physics fluctuation conductivity SC and of fluctuation Josephson effect in similar structures.

**ENERGY TRANSFER MECHANISMS IN ALKALI-EARTH
FLUORIDES DOPED WITH PR³⁺ IONS**

R. Y. Shendrik^{1,2}, E. A. Radzhabov^{1,2}, and A. I. Nepomnyashchikh^{1,2}

¹ *Vinogradov Institute of geochemistry SB RAS, Irkutsk, Russia,
roshen@yandex.ru*

² *Physics department of Irkutsk State University, Irkutsk, Russia*

Pr³⁺ ions are perspective dopant for scintillation materials [1]. Previous experiments [2] have demonstrated that SrF₂ doped with Pr³⁺ ions have a good temperature stability of light yield and could be used for well-logging application. The primary reason for the distinction in scintillation properties of these materials is rooted in different energy transfer mechanisms from primary electrons and holes to the rare earth ions. Exciton energy transfer takes place in the cerium doped crystals, but consecutive capture of electrons and holes is the main energy transfer mechanism in the fluorides doped with Pr³⁺ ions.

In this paper possible energy transfer mechanisms from primary electrons and holes to Pr³⁺ ions in CaF₂, SrF₂ and BaF₂ are observed. At room temperature dominating energy transfer mechanism is “delayed” electron-hole capture: consecutive capture of a free electron in Pr²⁺ center followed by capture of free hole resulting in an excited (Pr³⁺)* center decaying radiatively. At low temperatures in the SrF₂-Pr³⁺ and CaF₂-Pr³⁺ crystals the exciton transfer mechanism is found. In the paper contributions of the mechanisms are evaluated.

[1]. P. Dorenbos. Nuclear Science, IEEE Transactions on 57, 1162-1167 (2010).

[2]. R. Shendrik and E. Radzhabov. Nuclear Science, IEEE Transactions on 57, 1295-1299 (2010).

STUDY OF SeH⁻ - SeH⁻ DIMERS IN KCl CRYSTAL**E.A. Shteiner, A.D. Afanasyev¹**

Irkutsk State Technical University, Irkutsk, the Russian Federation,
egor.schteiner@mail.ru

¹ *Irkutsk State Technical University, Irkutsk, the Russian Federation,*
aad@istu.edu

We study the vibrational modes of diatomic SeH impurities, as well as their complexes in KCl crystals. This subject is of fundamental importance for the interpretation of spectroscopic data. For theoretical description of the defects and their vibrational spectra we used the quantum mechanical method based on polynomials of quantum numbers, as well as quantum chemistry method. Measurements of spectra were performed on the fourier - spectrometer Bruker IFS-125 at 2K and above.

It is shown that the distribution of intensities in the vibrational spectrum is due to the electrooptical anharmonicity of defects. It is proved that the form of pair lines belonging to the dimers of defects is determined by the dipole-dipole interaction between monomers of the dimer.

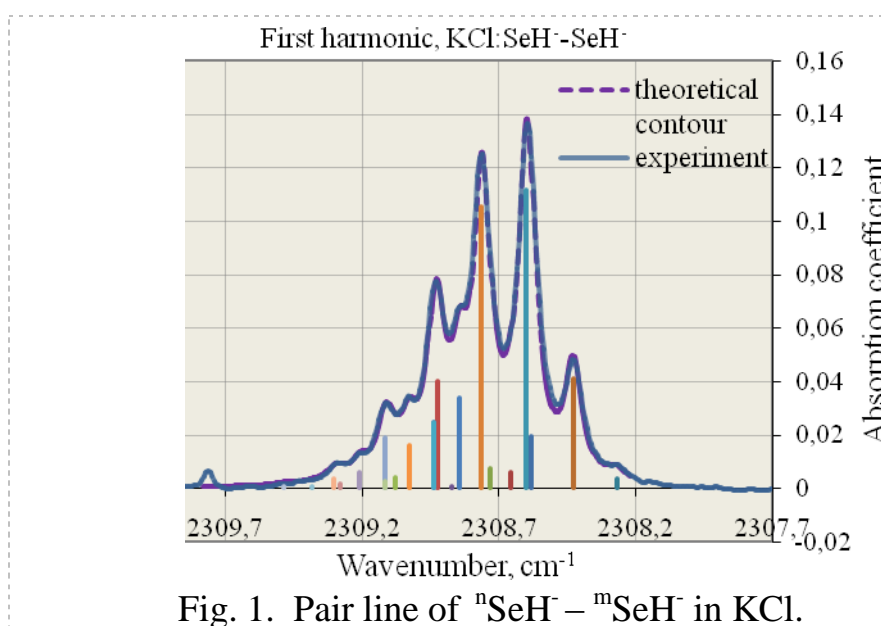

Fig. 1. Pair line of ⁿSeH⁻ – ^mSeH⁻ in KCl.

On fig. 1 the experimental pair line of ⁿSeH⁻ - ^mSeH⁻ is compared with contour, calculated theoretically for dipole - dipole interaction mechanism. The results of theoretical calculations show the excellent agreement with the experimental data.

Quantum - chemical models of isolated defects and different dimer configurations in the crystal matrix of KCl were calculated. The geometric and electro-optical parameters of the dimers were determined.

DIPOLE CURRENTS OF THERMOSTIMULATED DEPOLARIZATION IN ALKALI HALIDE CRYSTALS AT THE LATTICE SYMMETRY LOWERING

**K.Sh. Shunkeyev, A.A. Barmina, K.B. Bizhanova, D.M. Sergeyev,
S.K. Shunkeyev**

*Aktobe State Pedagogical Institute, Aktobe, Kazakhstan,
shunkeyev@rambler.ru*

In the present paper we study the effect of external electric field on the alkali halide crystals after the plastic deformation in which the subsidiary carriers are reoriented dipole defects. Such defects contributes to the total ionic conductivity.

It is known that in doped alkali halide crystals, as well as in the «pure» alkali halide crystals after plastic deformation the concentration of the «pure» X_3^- -centers significantly increases, which include divacancies [1]. Mechanism for the effective establishment of X_3^- -centers is explained by interaction of interstitial halogen atoms in the divacancies field $v_c^-v_a^+$ created by plastic deformation of crystals or impurities. This means that increasing the concentration of X_3^- -centers and more stacked halogen $[X_2]_{acac}$ -centers in plastically deformed alkali halide crystals shapes di $v_c^-v_a^+$ and vacancies quartets $2 v_c^-v_a^+$ [1].

Experimental measurements of the ionic conductivity temperature dependence of crystals KCl:Sr, KCl:Li and KCl after plastic deformation by the constant electric field influence can provide the dipole nature ion current. The concentration of divacancies was found in crystals of KCl:Sr, KCl:Li by experimental methods, but by direct experimental methods increase the concentration of di $v_c^-v_a^+$ and quartets of vacancies $2 v_c^-v_a^+$ in alkali halide crystals after plastic deformation haven't been registered. We carried out measurement of the ionic conductivity temperature dependence of the plastically deformed crystals to detect the vacancies high concentration. A direct experi-

mental method for the detection of a divacancy $v_c^-v_a^+$ in plastically deformed crystals is the thermally stimulated depolarization current registration, which appear in the process of dipolar defects reorientation of such as divacancies $v_c^-v_a^+$.

[1]. Vasilchenko E., Sarmukhanov E., Shunkeev K., Elango A. Electronic excitations in KBr and KI crystals near vacancy defects of different size // Phys. St. Sol. (b). - 1992. – V. 174. – p. 155-163.

RADIATION DEFECTS ON ALKALINE EARTH FLUORIDES DOPED WITH TRIVALENT IONS

T. Yu. Sizova¹, E. A. Radzhabov^{1,2}

¹ *Vinogradov Institute of Geochemistry, Siberian Branch of Russian Academy of Sciences, Irkutsk, Russia, sizova@igc.irk.ru*

² *Irkutsk State University, Irkutsk, Russia, eradzh@igc.irk.ru*

The behaviour of x-irradiated doped alkaline earth fluorides differs markedly from that of the pure crystals. The photochromic centers are produced either by x-irradiation or by additive coloration of CaF₂ and SrF₂ crystals doped with certain rare earth ions (La, Ce, Gd, Tb and Lu) or yttrium which have low third ionisation potentials. The photochromic centers can be considered as a trivalent rare-earth ion next to an anion vacancy (intrinsic defects which is not created by x-irradiation in the undoped crystals) with one (PC⁺ center) or two (PC center) trapped elec-

Impurity	Formation of photochromic centers in x-irradiated alkaline earth fluorides		
	CaF ₂	SrF ₂	BaF ₂
Y	PC 300K PC ⁺ 77K	PC 300K	not observed
La	PC 300K PC ⁺ 77K	PC ⁺ 80K	
Ce	PC 300K PC ⁺ 77K	PC 300K PC ⁺ 77K	
Gd	PC 300K PC ⁺ 77K	PC ⁺ 80K	
Tb	PC 300K PC ⁺ 77K	not observed	
Lu	PC 300K PC ⁺ 77K	not observed	

trons. The mechanism for creating PC centers in x-irradiated crystals is not clear so far.

Absorption spectra of photochromic centers, the thermal destruction in crystals of CaF_2 , SrF_2 , BaF_2 doped with trivalent ions of Y, La, Ce, Gd, Tb and Lu have been studied at temperatures 77-600 K. The data on formation of photochromic color centers in x-irradiated crystals of alkaline-earth fluorides doped with trivalent rare-earth ions are summarized in Table I. X-ray irradiation at 77 K cause to the formation of PC^+ and V_k centers (self-trapped hole which have the structure of molecular ion - F_2^-) in CaF_2 doped with Y, La, Ce, Gd, Tb and Lu. At temperatures in the ranges 350–450 K PC^+ centers are transformed into PC centers. In SrF_2 the PC centers are formed in the crystals doped with Y and Ce, while PC^+ centers are formed in SrF_2 doped with La, Ce and Gd. In BaF_2 crystals neither PC nor PC^+ centers are observed. The PC centers are created in combining the rare-earth ion and fluorine vacancy. We assume that loose lattice of BaF_2 favors a lower probability of combining the rare-earth ion and fluorine vacancy, therefore PC centers are not formed in these crystals.

ATOMISTIC SIMULATION OF STRUCTURE AND PROPERTIES OF SOLID AND LIQUID URANIUM

D. E. Smirnova, S. V. Starikov, V. V. Stegailov

*Joint institute for high temperatures RAS, Moscow, Russia,
d.e.smirnov@gmail.com*

Using the force matching method we develop an interatomic potential that allows to study the structure and properties of α -U, γ -U and liquid uranium. The potential is fitted to the forces, energies and stresses obtained from *ab initio* calculations. The potential form is chosen to be within the frame of the embedded atom model. The potential is applied for molecular dynamics computation of a number of thermophysical and mechanical properties of the uranium phases. The results obtained for lattice parameters, elastic properties of α -U and γ -U, room-temperature isotherm and normal-density isochore of α -U are consistent with the experiment. The calculated melting line of uranium at the pressure up to 80 GPa and the temperature of α -U \leftrightarrow γ -U solid-solid phase transition at the pressure \sim 3 GPa agree well with the experimental phase diagram of uranium. The predicted Grüneisen parameter for

liquid and solid uranium phases compares well with the known experimental data. The single defect (vacancy, self-interstitial atom) formation energies in α -U and γ -U conform to the known experimental measurements as well as to the results of *ab initio* calculations. The potential developed provide a powerful tool for study the behavior of the uranium phases in a wide range of pressures and temperatures. Especially it can be used for simulation of the processes taking place in the nuclear fuel material in the working conditions, such as fission tracks formation occurring in irradiated material or evolution of the radiation defects.

EXPLANATION AND TESTING OF THE MODEL FOR COMPUTER CALCULATIONS OF LUMINESCENCE SPECTRA AND PHOTO-LUMINESCENCE DECAY KINETICS UNDER PULSED LASER EXCITATION IN SILICON DIOXIDE CRYSTALS

T. V. Spiridonova, V. S. Kortov, S. V. Zvonarev

Ural Federal University named after the first President of Russia B.N. Yeltsin, Ekaterinburg, Russia, forSpiridonova@gmail.com

Laser radiation usage provides an opportunity to do complex study of luminescence excitation mechanisms and other secondary processes arising when dielectric absorbs photons with energy ranging from several electron volts to hundreds of kilo-electron volts. SiO₂ is of special interest for photoluminescence (PL).

The aim of this paper is to develop a physical model for luminescence spectra and PL decay kinetics calculations in wide-gap dielectric oxides under pulsed laser excitation as well as to create calculation algorithm and program for the developed model testing.

Physical model of interaction between pulsed laser radiation and dielectric as well as further luminescence processes were considered. Being excited as described, photons interact with substance atoms and give all their energy to electrons which leave atoms and enter conduction band. Further on, electrons experience inelastic scattering on valence electrons. This gives rise to secondary nonequilibrium electron-hole pairs which can recombine giving energy to luminescence centers. Thus luminescence occurs in a certain spectral region.

The algorithm and program for luminescence spectra and SiO₂ luminescence decay kinetics calculations under pulsed laser excitation have been developed. Calculations of the processes under study were made while the samples were exposed to excimer laser radiation KrF (wavelength of 0.249 μm, radiation pulse duration of 10 ns).

The main luminescence centers in the material under study are oxygen-deficient centers (ODC). α-ODC luminescence spectrum under laser radiation excitation has two constituents – at 2,7 eV (458 nm) and at 4,45 eV (277 nm). β-ODC luminescence spectrum also has two peaks – at 3,1 eV (399 nm) and 4,3 eV (288 nm).

Simulation of PL decay kinetics in single-crystal SiO₂ showed that in nanosecond relaxation time region band luminescence of 4,45 eV and 4,3 eV with decay time $\tau_{\alpha-ODC}(4.45\text{eV}) \approx 5\text{ ns}$ and $\tau_{\beta-ODC}(4.3\text{eV}) \approx 30\text{ ns}$ prevails. Whereas in millisecond region band luminescence of 2,7 eV and 3,1 eV with decay time $\tau_{\alpha-ODC}(2.7\text{eV}) \approx 1.3\text{ ms}$ and $\tau_{\beta-ODC}(3.1\text{eV}) \approx 0.6\text{ ms}$ prevails. The obtained results are in good agreement with the data reported in the literature where the given parameters are $\tau_{\alpha-ODC}(4.45\text{eV}) \approx 7.86\text{ ns}$, $\tau_{\beta-ODC}(4.3\text{eV}) \approx 31\text{ ns}$, $\tau_{\alpha-ODC}(2.7\text{eV}) \approx 0.91\text{ ms}$, $\tau_{\beta-ODC}(3.1\text{eV}) \approx 0.36\text{ ms}$ correspondingly. Similar values of the calculated and experimental data on PL decay kinetics in SiO₂ prove the validity of the physical model.

**OPTICALLY AND THERMALLY STIMULATED
LUMINESCENCE OF NANOPOWDERS AND THIN FILMS OF
ALUMINUM OXIDE**

**A. I. Surdo^{1,2}, S. Yu. Sokovnin³, I. I. Milman², V. G. Il'ves³,
M. I. Vlasov¹, R. M. Abashev², A. V. Boldesh²**

¹ *Institute of Industrial Ecology, UB RAS, Yekaterinburg, Russia*

² *Ural Federal University, Yekaterinburg, Russia*

³ *Institute of Electrophysics, UB RAS, Yekaterinburg, Russia*

At present different methods of nanostructured material coating is one of the most perspective techniques to obtain thin layers. This study investigates the OSL- and TL- properties of thin layers of nanostructured aluminum oxide. These layers have been obtained using high purity α-Al₂O₃ powder

evaporation by electron-, ion- and laser- beam with and without extra sedimentation.

The work presents the results of the X-ray phase analysis (XFA) as well as electron-microscopic studies of synthesized thin layers of nanostructured aluminum oxide. It follows that the size of nanoparticles in most TL- and OSL-active coatings is from 5 nm to 10 nm. According to preliminary analysis of the XFA data the phase structural composition of the obtained layers is rather complicated. Only amorphous- and gamma- phases have been clearly distinguished as yet.

It is shown that thin layers obtained by evaporation of a target using electron pulse beam ($E=100$ keV, $\tau=20 - 300$ μ s, $j\geq 1$ MJ/cm²), with subsequent sedimentation on cooled aluminum, copper, steel, quartz, and glass substrates demonstrate high TL- and OSL- yields. The TL- and OSL-yields of the given coatings with standard square and thickness are close to those for TL- and OSL – detectors based on anion-defective corundum. The TL glow curve shows an unusually wide peak within the 300-800 K range with its maximum at 450 K ($\beta=2$ K/s) and features at 370 and 670 K. At continuous blue LED stimulation ($\lambda_{\max}=470$ nm) the OSL decay curve can be described by two exponents ($\tau_1\approx 12$ s and $\tau_2\approx 110$ s) with considerable contribution from the slow component ($I_1\tau_1/(I_2\tau_2)\approx 0.5$). Dose dependences of the TL- and OSL- yields are linear within the $20-4\cdot 10^4$ mGy range. Above all, the influence of the active layer thickness, substrate material, and the isochronous annealing temperature on the TL- and OSL- yields has been studied.

This work was supported by the Russian Foundation for Basic Research (project no. 10-08-96045) and by Presidium of the Ural Branch of the Russian Academy of Sciences (project no. №12-U-2-1032).

RADIATION DAMAGE OF CsI AND CsI:Tl CRYSTALS CONTAINING IMPURITIES OF CARBONATE AND HYDROXIDE

**L.N. Trefilova, V.Yu. Yakovlev¹, V.D. Alekseev², A.N. Meleshko¹,
A.I. Mitichkin²**

*Institute for Scintillation Materials of NASU, Kharkov, Ukraine,
shpil@isc.kharkov.com*

¹ *Tomsk Polytechnic University, Tomsk, Russia, yak999@rambler.ru*

² *Institute for Scintillation Materials of NASU, Kharkov, Ukraine, alekseev@isma.kharkov.ua*

It is known [1] that CsI and CsI:Tl crystals containing both hydroxide and carbonate impurities are highly prone to radiation damage which, however, can be dramatically reduced by Na⁺ ions. The aim of this study is to examine the function of CO₃²⁻ and OH⁻ ions in color center formation as well as the function of Na⁺ ions in hardening of these crystals against radiation damage.

Three samples CsI, CsI:1.0·10⁻² mol% Tl and CsI:1.0·10⁻² mol% Na containing no less than 1·10⁻⁴ mol% of OH⁻ ions and about 8·10⁻⁵ mol% of CO₃²⁻ have been investigated. By comparison of absorption vibration spectra of the crystals we have found that CsI has four ν₃-vibration bands of CO₃²⁻ ions at 1355, 1365, 1385, 1410 cm⁻¹, CsI:Tl has two more at 1330 and 1440 cm⁻¹, and CsI:Na has only one band at 1450 cm⁻¹. The bands at 1355, 1365, 1385, 1410 cm⁻¹ are caused by CO₃²⁻-ν_a⁺ dipoles which are found amidst lattice ions in CsI:Tl crystal. Both bands at 1330 and 1440 cm⁻¹ are attributed to CO₃²⁻ ions under perturbation of Tl⁺ ions, and the band at 1450 cm⁻¹ caused by CO₃²⁻ ions under perturbation of Na⁺ ions, which means that all CO₃²⁻ ions are found near activator ions in CsI:Na unlike CsI:Tl.

After irradiation of CsI and CsI:Tl, the intensity of the bands at 1355, 1365, 1385, 1410 cm⁻¹ drops down with arising of bands at 1223, 1315, 1679 cm⁻¹ attributed to HCO₃⁻ in both crystals and two more unknown bands at 1300 cm⁻¹ and 1500 cm⁻¹ in CsI(Tl). As for the ν₃-bands at 1330 and 1440 cm⁻¹ in CsI:Tl as well as at 1450 cm⁻¹ in CsI:Na, their intensity remains unchanged after irradiation. No more bands have been observed in the spectra of vibration absorption and electron absorption of CsI:Na, though the bands attributed to F⁻ and Tl⁰ν_a⁺ centers arise in the spectrum of irradiated CsI and CsI:Tl, respectively.

The suggested mechanism of radiation damage of CsI is as follows: CO₃²⁻ ion, which is found amidst lattice ions, captures a mobile hole and

turns into CO_3^- radical, while v_a^+ captures a conduction electron and turns into F-center. Then CO_3^- radical turns into a HCO_3^- by capturing an interstitial hydrogen H_i^0 , which arises owing to OH^- ion dissociation caused by irradiation, otherwise CO_3^- radical turns back into CO_3^{2-} due to electron tunneling from F-center.

In CsI(Tl), the number of Tl^+ ions is overwhelmingly bigger than that of anionic vacancies originated by CO_3^{2-} ions. Therefore only Tl^+ ions capture conduction electrons, turning into Tl^0 centers. When CO_3^{2-} turns into either CO_3^- or a HCO_3^- radical, anionic vacancies begin to move towards negatively charged Tl^0 centers, resulting into stable $\text{Tl}^0 v_a^+$ centers. We attribute the bands at 1300 cm^{-1} and 1500 cm^{-1} to CO_3^- radical. Similar bands with maxima at 1300 cm^{-1} and 1494 cm^{-1} are also observed in the vibration absorption spectrum of isolated CO_3^- radical anions [2]. Once Tl^+ ions are found near CO_3^{2-} ions, they capture holes, resulting into V_{KA} or Tl^{2+} centers, preventing CO_3^- from formation.

In CsI:Na, all CO_3^{2-} ions are found near Na^+ ions which intercept holes, giving rise to V_{KA} centers. The latter prevents CO_3^{2-} ions from turning into either CO_3^- radicals or HCO_3^- ions.

[1] L. N. Trefilova, A. M. Kudin, N. N. Kosinov, et al. Role of sodium in radiation defect formation in CsI(Tl) crystals // *Rad. Measur.*, 2001, V.32, pp.688-692.

[2] E. J. Marilyn, , E. Dolphus, E. Milligan. Matrix-isolation study of the vibrational spectrum and structure of the CO_3^- radical anion // *J. Mol. Spectrosc.*, 1974, V.52, pp. 363-379.

LUMINESCENCE AND DOSIMETRIC PROPERTIES OF THE $(\text{Er}^{3+}, \text{Dy}^{3+})\text{:YAG}$ CRYSTALS

M.I. Vlasov¹, A.I. Surdo^{1,2}, I.I. Milman², V.I. Solomonov³, A.V. Spirina³

¹ *Institute of Industrial Ecology, UB RAS, Yekaterinburg, Russia*

² *Ural Federal University, Yekaterinburg, Russia*

³ *Institute of Electrophysics, UB RAS, Yekaterinburg, Russia*

Investigations of the radiation and optical properties of the yttrium aluminium garnet (YAG) crystals activated by the trivalent erbium and dyspro-

sium ions were held. Besides, there was done comparative analysis of the dosimetric and luminescence properties of the studied samples and TLD-500K detectors based on anion-defective corundum.

In the study of the impulse cathodoluminescent spectrum (ICL) it was found that the most intense luminescence of the $(\text{Er}^{3+}, \text{Dy}^{3+})$:YAG crystals is observed at the visible range of spectrum, less intense – at the IR- and UV-ranges. It was shown that the thermoluminescence (TL) curves of the $(\text{Er}^{3+}, \text{Dy}^{3+})$:YAG samples measured at a wide spectrum range 200-800 nm have a simple form with a single peak centered at 170 °C which thermo activation processes can be presented by a monomolecular kinetic very well. More over, it was found that a slight deposit into a luminescence yield near 126, 170 and 255 °C gives UV-emissions that were also detected in the TL and ICL spectrums.

The fading of the irradiated $(\text{Er}^{3+}, \text{Dy}^{3+})$:YAG crystals due to storage under the light and in the dark was studied. It was found that under the influence of daylight half of TL yield stored due to irradiation is lost within 20 minutes.

Continuous wave optically stimulated luminescence (CW-OSL) decay curves were studied using white and blue (470 nm) LEDs. The received curves with high accuracy can be presented by the sum of two exponents. The most significant deposit into the OSL yield gives the slow component while stimulation is done by the blue LED, and the fast component while stimulation is done by the white LED. Using of the white LED give some advantages in comparison with the blue LED, namely reduction of the measurement time, increasing of the OSL yield and of the initial intensity.

By the comparative studies of the TL, OSL and dose-response dependences of the $(\text{Er}^{3+}, \text{Dy}^{3+})$:YAG crystals with TLD-500K detectors it was shown that YAG samples doped with RE- elements can be referred to a promising TL- and OSL-dosimetry materials. It was determined that at a dose range $10^{-2} - 1$ Gy TL and OSL responses of YAG samples with prescribed concentrations of Er^{3+} and Dy^{3+} ions are two orders of magnitude lower than TLD-500K.

Research was supported by RFBR (grants № 10-08-96045, 10-08-0078a) and UB RAS (projects №12-U-2-1032, 12-2-003-YC).

LUMINESCENCE OF $\text{Li}_6(\text{Gd,Y})(\text{BO}_3)_3:\text{Ce}$ FIBERS**D. O. Vostrov, I. N. Sedunova, I. N. Ogorodnikov, V. Yu. Ivanov***Ural Federal University, Yekaterinburg, Russia, qipqup@yandex.ru*

The Ce-doped lithium lanthanide borates present a class of new scintillators. The $\text{Li}_6(\text{Gd,Y})(\text{BO}_3)_3:\text{Ce}$ incorporate the popular neutron absorbing nuclei with high cross-sections (B, Li and Gd) and consequently it is considered as a potential material for thermal neutron detection. The investigation of scintillation characteristics of LGBO:Ce materials in bulk or powder forms was carried out early [1-2]. The present work is devoted to studying the recombination processes in fibers at VUV and soft X-Ray excitation.

$\text{Li}_6(\text{Gd,Y})(\text{BO}_3)_3:\text{Ce}$ were produced using micro pulling down method at Universite Lyon 1 (Lyon, France) at argon atmosphere. Luminescence spectra and luminescence excitation spectra were measured on BW3 channel of DORIS synchrotron and SUPERLUMI station (HASYLAB, DESY, Hamburg).

The luminescence spectra are characterized by the presence of two bands – narrow peak at 3.97 eV associated with gadolinium emission and wide band at 2.8-3.2 eV related to 5d→4f electron transitions in cerium. The luminescence spectra are not elementary ones and it testifies to the presence of different emission centers. The profile of these spectra depends on excitation energies that can indicate on the different mechanisms of energy transfer. In luminescence excitation spectra of fibers we have observed the dips at 148 eV and 193 eV related to N-edge of gadolinium ions absorption and K-edge of boron ions absorption respectively. The decay time of cerium luminescence is not elementary and includes the short component. We discuss in the paper the peculiarities of electron excitations dynamics and recombination processes in fibers that explain the experimental data.

[1] J.B. Czirr, G.M. MacGillivray, R.R. MacGillivray et al. Nucl. Instr. and Methods in Phys. Res. A 424, 15 (1999).

[2] I.N. Ogorodnikov, V.A. Pustovarov, S.I. Omelkov et al. Optics and Spectroscopy 102, 60 (2007).

**KINETICS OF SHORT-LIVING OPTICAL ABSORPTION IN
BINARY LEAD SILICATE GLASSES**

**I. S. Zhidkov, A. F. Zatsepin, A. I. Kukharenko, V. Yu. Yakovlev¹,
S. O. Cholakh**

*Institute of Physics and Technology, Ural Federal University,
Yekaterinburg, Russia, i.s.zhidkov@ustu.ru*

¹ *Institute of High Technology Physics, Tomsk Polytechnic University,
Tomsk, Russia*

Lead silicate glasses are widely used as optical media, radiation-resistant materials, and emission-active elements of optoelectronic converters such as microchannel plates, secondary-electron multipliers of charged particles, and ionizing radiation detectors. To optimize the electronic and optical properties requires a detailed study of both the initial non-irradiated glasses and samples exposed to radiation fields, including the effects of pulsed accelerated electron beams.

Unstable color centers produced on commercial flint glasses by pulsed electron beams effects were investigated in [1]. The objects of study in this work were glass with a relatively low content of lead oxide. At the same time, for a detailed understanding of the formed short-lived centers nature is necessary to investigate the glass in a compositions wide range. The aim of this work was to investigate the nature and dynamics of unstable color centers in the whole glass formation region, including the glass with the inversion-range order [2].

In this work the methods of pulsed absorption spectroscopy at liquid nitrogen temperatures were used to study the optical properties of $x\text{PbO}\cdot(1-x)\text{SiO}_2$ glasses ($25 < x < 75$) produced by cooling of a molten mixture of chemically pure oxides. Analysis of short-living optical absorption spectrum shows the presence of elementary bands at 1.65 eV and 2.3 eV. In low-lead samples ($\text{PbO} < 50$ mol%) is dominated by absorption at 2.3 eV. Increasing lead oxide concentration leads to an increase in optical density of 1.65 eV. Found that lowering the temperature to 80 K leads to a decrease in optical density. Decay kinetics of the optical density (2.4 eV band) is non elementary and represent the sum of fast and slow components. The slow component is well described by a hyperbolic dependence, typical for the process of tunneling recombination. Rising concentrations of PbO leads to a decrease in the rate of recombination processes. In high-lead glasses ($\text{PbO} > 50$ mol%) change in the characteristic decay time of the optical density with increasing

content of lead oxide is different from the analogous dependence for low-lead samples.

The established regularities are interpreted on the basis of a model that takes into account the inversion of the short-range order. It is shown that the transient optical absorption due to the formation in the localized states tails of the so-called "amphoteric» (Pb^{2+})/ h^+ and (Pb^{2+})/ e^- centers, the ratio between which depends on the nature and geometry of the structural motifs of glass.

[1] V.I. Arbuzov, A.O. Volchek, A.I. Gusarov et al. *Journal of Optical Technology* 71 (2004) 111.

[2] A.F. Zatsepin, A.I. Kukharenko, D.A. Zatsepin et al. *Optical Materials* 33 (2011) 601.

THE CRYSTAL STRUCTURE of DINITRIDE-NITRIDE N_2MN (M: Cu, Ag)

J.N. Zhuravlev*, **V.M. Lisitsyn**, **E.Ju. Morozova**

*National Research Tomsk Polytechnic University, 30, Lenin av.,
634030, Tomsk, Russia*

**Kemerovo State University, 6, Red st., 650043, Kemerovo, Russia*

The compounds of copper, silver with nitrogen have been researched with the first-principle linear combination of the atomic orbitals in full-screen basic with the local gradient and hybrid potential of the density functional theory realized in the CRYSTAL09 program code. The structural N_2MN (M: Cu, Ag) dinitride-nitride phase having an orthorhombic structure, the spatial group of the *Ibam* symmetry and four formula units in the primitive cell that have not been reported in any literature before has been found. The structure was found to be layered, the metal atoms are linearly circled by the nitride N atoms, whereas, the two other atoms make a molecule with a small negative charge of $\sim 0.02 e$. The volume elastic modules in N_2CuN , N_2AgN crystals are equal to 4.3 and 6.6 GPa, respectively, and their pressure derivatives are equal to 6.7 and 5.3, respectively. The estimations of the enthalpy energies show that N_2MN possess large energy content and in its decomposition to metal and gaseous nitride the energy release can make the value of the order of 8 eV/cell, which appears to be higher than that in the known metal azides. Thus, the new structure of the dinitride-nitride N_2MN

combines the properties of molecular and semiconductor crystals: high compressibility and strong mechanical anisotropy, localized vacant states found in the zone spectrum, and small width of the band gap. The unique physical properties can insure their application, as energy materials and as the source of chemically pure nitride and in semiconductor and optical material science.

**INITIATION OF PENTAERYTHRITOL TETRANITRATE
MONOCRYSTALS BY IMPULSE BEAM OF ELECTRONS**

B.P.Aduev, G.M.Belokurov, S.S.Grechin, I.Ju.Liskov

*Institute of coal chemistry and material science SB RAS,
Russia, Kemerovo
lesinko-iuxm@yandex.ru*

Results of measurement of knock and spectral-kinetic values of explosive luminescence and optical absorption of pentaerythritol tetranitrate (PETN) monocrystals initiated by impulse beam of electrons (0.25 MeV, 20 ns, 15 J/cm²) are surveyed.

Spatial and dynamic picture of luminescence under explosion of PETN monocrystals with the thickness 1-1.5 mm was measured by using streak-camera "Vzglyad-2A". It is discovered under impact of electron beam with energy density 15 J/cm² shock wave spreads from irradiated part of crystal. When it is reflected from rigid barrier, on the back side of the crystal appears a detonation wave which spreads to the side of irradiated area with the velocity 8000-8500 m/s. When there is no a rigid barrier, detonation is not observed (under energy density 40 J/cm²), but there are electric disruption, fore-explosive luminescence and explosive of irradiated crystal area. Spectral-kinetic values of explosive luminescence, optical absorption of PETN monocrystals and luminescence of explosion products are measured with using polychromator coupled with streak-camera. In the spectrums of crystal luminescence at the radioluminescence stage excitons (3.1 eV), NO₂-radicals (2.4 eV) and, presumably, NO₃-radicals (1.5 eV) are observed. At the detonation stage band 1.5 eV is dominated one. At the moment of electron beam impact in the absorption spectrums NO₂ and NO₃-radicals are observed.

As a conclusion it can be noticed mechanism of detonation initiation is a shock-wave type. The action of electron beam results in threshold crossing in the irradiated layer and as a result of that initiation of exothermic reaction. Gain shock wave is formed as a result of beam energy absorption and heat generation of chemical reaction. Apparently reaction initiation relates to tearing away NO₃-group from PETN molecule.

**LASER INITIATION OF PENTAERYTHRITOL
TETRANITRATE WITH ADDITIVES OF ALUMINIUM AND
ALUMINA NANOPARTICLES**

B.P. Aduev, D.R. Nurmukhametov, R.I. Furega

*Institute of coal chemistry and material science SB RAS,
Russia, Kemerovo
lesinko-iuxm@yandex.ru*

Dependences of explosive probability under impulse laser exposure (1064 nm, 12 ns) of pentaerythritol tetranitrate (PETN) with the density $\rho = 1,73 \text{ g/sm}^3$ with various content of aluminum nanoparticles were investigated. Particles size in the maximum distribution is 100nm, content of active Al in a particle is 73% mass and 27% Al_2O_3 . It was observed the more sensitivity ($H_{cr} = 1,75 \text{ J/sm}^2$) is achieved when optimal concentration of nanoparticles is 0.1% mass. At that mixture sensitivity to the laser initiation rises in 100 times in comparison with the same for samples without nanoparticles. For clearing of influence of dispersion and absorption of radiation by nanoparticles the following experiments were realized. PETN explosive decomposition threshold was measured. Optimal concentration of nanoparticles with various content of active aluminum in a particle within 71%-0% (Al_2O_3) was used. This variance of active aluminum content was obtained by annealing of initial particles up to various oxidation rates. Al_2O_3 particles are transparent for laser radiation and in this case only effects of radiation dispersion can influence to threshold of explosive decomposition. It is showed the observed effect of falling of PETN explosive decomposition threshold is based mainly on presence of particles with high concentration of active aluminum. This fact results in the conclusion that as a result of radiation absorption there is heating of nanoparticles with forming focuses of chemical decomposition about a "hot-point", and dispersion effects play sidetrack.

COMPARATIVE ANALYSIS OF THE ENERGETIC MATERIALS EXPLOSION PROCESS'S CHAIN AND THERMAL MECHANISMS

**M. V. Ananyeva, V. G. Kriger, A. V. Kalenskii, A. A. Zvekov¹,
A. P. Borovikova, E. A. Grishaeva, I. Yu. Zykov**

Kemerovo State University, Kemerovo, Russia, kriger@kemsu.ru

¹ *Institute of coal chemistry and materials science, Kemerovo, Russia,
Zvekov@gmail.com*

Chain and thermal mechanisms of the energetic materials' explosive decomposition have the same nature since the source of energy is chemical reaction. Because of this some experimental data can be explained in terms of thermal and chain model at the same time. But in case of chain nature the active particles' concentration considerably exceeds thermodynamic average value for this temperature, in case of thermal model the concentration is near to the thermodynamic average concentration. This difference defines what kind of experiments should be carried out to choose one of the models as the best fitted to describe the explosive decomposition process:

- Controlled inclusion of impurities in the sample and further determination of the impurities' influence on the critical parameters and the explosive decomposition kinetics. In case of the chain explosion initiation mechanism critical energy is more sensible to the concentration of impurity, which gives an energetic level near to the band gap center (for example, a few-atomic metal clusters) – chain termination centers. This impurities cause the decrease of the sensitivity to the laser pulse action. In case of thermal initiation mechanism the sensitivity to the irradiation can be achieved if the impurities' sizes are 10-100 nm. These impurities absorb well irradiation and act as heating centers and form the initial reaction centers.

- Size effects investigation: critical energy density dependence on the crystal size and impulse's diameter in case of laser initiation. As soon as typical electron excitations' diffusion coefficients exceed in 2-3 times the thermal conductivity value the regions of the size effects for the chain and thermal explosion are different.

- The explosive decomposition process wave space-time characteristics in the energetic materials. The propagation velocity, weight on the half-height on the front and on the bottom of the reaction edge, their dependences on the impulse parameters and crystal characteristics differ considerably (in 2-5

times) according to the calculations in terms of chain and thermal explosion model.

Comparison of the calculation with the experimental data made it possible to conclude that in case of laser initiation silver azide's explosive decomposition is caused by the solid state branched chain reaction. Explosive decomposition of the brisant explosives, which contain nanosized inclusions, could be explained in terms of the thermal explosion model. Authors thank the Russian Foundation for Basic Research for financial support (№ 11-03-00897).

IMPACT OF HIGH INTENSITY FS AND NS OPTICAL PULSE EXPOSES UPON DOPED GASE

**V.V. Atuchin¹, S.V. Alekseev², Yu.M. Andreev³, K.A. Kokh⁴,
G.V. Lanskii³, V.F. Losev^{2,6}, D.M. Lubenko², Yu.N. Punchenko⁶,
A.V. Shaiduko³, V.A. Svetlichnyi⁵**

¹*Semiconductor Physics Institute of SB RAS, Novosibirsk, Russia*

²*High Current electronic Institute of SB RAS, Tomsk, Russia*

³*Institute of Monitoring of Climatic and Ecological Systems of SB RAS,
Tomsk, Russia, yuandreev@yandex.ru*

⁴*Institute of Geology and Mineralogy SB RAS, Novosibirsk, Russia*

⁵*Siberian Physical-Technical Institute of Tomsk State University,
Tomsk, Russia*

⁶*High Current Electronic department of Tomsk Polytechnic University,
Tomsk, Russia*

Doped GaSe are the efficient media for THz generation by different technique. We grown GaSe crystals doped with isovalent element (Al, S, In, Te, Er) in two-zone vertical furnace by Bridgman technique and studied them to reveal potentials for THz generation under fs Ti:Sapphire laser (0.95 μm) and OPG system (1.1-2.9 μm), 40-50 ns TEA CO₂ (9.2-10.8 10,6 μm) and 250 ns Er³⁺:YAG (2.79 μm) laser pumpings. To characterize quality of output THz beams versus pump intensity we first studied impact of high intensity pulse exposes upon doped GaSe by transmission measurement and microscopy. Both different nature and common features were established in the crystal damage processes under the studied pump. In low quality crystals first local surface craters and gaps between layers (in bulk) appeared under

the fs pump at the location of second phase inclusions whose size is comparable with or exceed the pump wavelength. Much larger (close to and larger than beam cross section) size gaps appeared at the locations of already existing small size local gaps. At higher pump intensity the local damages are growing up in size on the lone of extending area of black color substance. Small (sub- μm) thick black color substance layer was identified as Ga_2Se_3 appeared during cooling (re-crystallization) the heated area. Further increase in the pump intensity leaded to Ga_2Se_3 rejection in the central part that show not damaged surface features (dislocations, broken layers). This process does not change transparency and can be multiply repeated by pump intensity variation down and back. Finally, further increase in pump intensity is resulted in Se evaporation, Ga_2Se_3 and rest Ga balls formation on the crystal surfaces. Last process makes crystal not transparent, i.e. real damaged. In high quality crystals only Ga_2Se_3 formation process was observed. Under TW/cm^2 pulse intensity we observed result of strong thermal strike on the sub- μm surface layer. Under the ns pulse pump in high quality crystals sub- μm and even nano sized inclusions were heated and surrounded by Ga_2Se_3 regions that grow up in size with pump intensity till formation bulk region of Ga_2Se_3 . Due to comparative time constants of heat process in doped GaSe and pulse duration the damage volumes were mm-depth and exceed pump beam diameter in size. The difference in pump intensity in S-doped and other crystals was found due to difference in two-photon absorption.

Acknowledgment: Presidium SB RAS in the frame of Interdisciplinary Integrated Project No.46 of 2012 and RFBR Grant № 12-08-00482.

GENERATION OF LASER LINES AND NON-LINEAR SELF-ADDITION THEIR FREQUENCIES AT POWERFUL ELECTRON-BEAM PUMPING OF ER:BaY₂F₈ CRYSTALS

V.I. Baryshnikov¹⁻³, V.V. Krivorotova¹

¹*Irkutsk State Railway University, Irkutsk, Russia.*

²*Irkutsk Filial of Laser Physics Institute at SB RAS. Irkutsk, Russia.*

³*Applied Physics Institute of Irkutsk State University, Irkutsk, Russia*

E-mail: vibh@rambler.ru.

Oxide (Er:Y₃Al₅O₁₂, Er:Y₃Al₅O₁₂, Er:YAlO₃) and fluoride (Er:BaY₂F₈, Er:YLiF₄, crystals (concentration of Er³⁺ 0,1–1.0 wt. %) are in-

investigated as potential laser medium. The cathode luminescence (CL) of Er^{3+} lines in these crystals at 300 K are excited by powerful nanosecond electron-beams (250 keV; 0,5 – 2,0 kA/cm²; 5 ns). Experimental results shown on high yield luminescence lines: infrared (IR) – (1230 nm, 1650 nm, 2740 nm and 2900 nm), green (541 nm, 553 nm) and red (655 nm, 700 nm). The spectral distribution of green, red and IR lines of CL correspond to the known radiative electron transitions in Er^{3+} ions [1]. In these crystals the yield (η) of Er^{3+} CL achieves ~10 % at concentration of Er^{3+} ~ 0,1 wt. % [2]. Analysis of the results for these crystals shown that hot electrons and holes are interact with impurity Er^{3+} defects at the efficiency on two orders higher then with regular nodes of lattice. The difference of electron structures of intrinsic $\text{Y}^{3+} - 4p^6$ and impurity $\text{Er}^{3+} - 5p^6$ ions explains the high yield of the IR, green and red Er^{3+} emission. This means that in vicinities of impurity defects a potential of crystalline field U^* , formed mainly by p -subgroups of valence shell of impurity Er^{3+} ions as a function from $(r + a)$ is irregularity, principle of Bloch is violated and the hot electrons and holes effectively send the energy to the impurity Er^{3+} defects on reactions [2]: $\text{Er}^{3+} + e \rightarrow (\text{Er}^{2+})^* \rightarrow \text{Er}^{2+} + h\nu_{\text{Er}^{2+}} \rightarrow \text{Er}^{2+} + h \rightarrow \text{Er}^{3+}$ and $\text{Er}^{3+} + h \rightarrow \text{Er}^{4+} + e \rightarrow (\text{Er}^{3+})^* \rightarrow \text{Er}^{3+} + h\nu_{\text{Er}^{3+}}$.

The produced results show an possibility of generation of laser radiation in $\text{Er}:\text{BaY}_2\text{F}_8$ crystals at powerful nanosecond electron-beam pumping. In these experiments the small-sized high-current electron-beam accelerator was used with low-inductance cryostat, containing precision system positioning of the totally reflecting aluminum mirror in the open resonator adjusted on full internal reflection of light from the surface of $\text{Er}:\text{BaY}_2\text{F}_8$ crystal pumping by high-current electron-beam. At nanosecond electron-beam pumping of $\text{Er}:\text{BaY}_2\text{F}_8$ crystal (concentration of Er^{3+} ~1 wt. %) on current density $> 1,0$ kA/cm² the generation of IR (1650 nm, 2740 nm) red (655 nm, 700 nm) green (541 nm and 553 nm) blue (449 nm, 456 nm) and violet (407 nm, 414 nm) lines of laser radiation was achieved. Observation was produced by system, structure of which contains spectrograph - grating polychromator and color CCD matrix. The separating 4 %-glass plate with $p-i-n$ photodiode and oscilloscope were used for kinetic measurements.

At powerful nanosecond electron-beam pumping of $\text{Er}:\text{BaY}_2\text{F}_8$ crystals the lines of laser radiation in violet - 407 nm, 414 nm and blue - (449 nm, 456 nm) spectral ranges are not correspond to known radiative electron transitions in Er^{3+} ions [1]. The analysis has shown, that on high-current electron-beam pumping of $\text{Er}:\text{BaY}_2\text{F}_8$ crystals the lines of laser radiation at 407 nm, 414 nm and 449 nm, 456 nm are formed by non-linear self-addition of frequencies of complicate green laser lines at 541 nm and 553 nm according to

frequency of a laser line at 1650 nm and line at 2740 nm.

- [1]. A.A. Kaplyanskii. Spectroscopy of crystals, Nauka, 1983. 232 p.
[2]. V.I. Baryshnikov, V.V. Krivorotova. Phys. Stat. Sol. (Rus), 2008, V.50, №9, P.1600-1602.

THE TIME-SPACE PARAMETERS OF THE EXPLOSIVE DECOMPOSITION OF ENERGETIC MATERIALS MOVING REACTION WAVE

**A. P. Borovikova, V. G. Kriger, A.V. Kalenskii,
M. V. Ananyeva, A. A. Zvekov¹**

Kemerovo State University, Kemerovo, Russia, kriger@kemsu.ru

¹*Institute of coal chemistry and material science, Russia,
Zvekov@gmail.com*

The objective of the present paper is theoretical and experimental study of explosive decomposition reaction propagation in silver azide crystals.

A special experimental cell was used for the front velocity propagation measurement in the sample. The space parameters of the moving reaction wave were determined with three developed methods:

1. Estimation of the wave width using the time, which the reaction needs to pass over a graduated hole in the basement.

2. Reducing of the spatial distribution of the irradiation intensity in the reaction wave. The wave form is approximated by an expression containing a set of parameters that are determined by experimental kinetics and the theoretical one fitting.

3. The third approach consists in the experimentally obtained glow kinetics transformation into the reaction wave profile by an integral operator, which is determined by the hole's shape in the cell.

The average space characteristics of the reaction wave in silver azide crystals initiated by a laser pulse were received. The rising edge width at half maximum is $l_1 = 110 \pm 10 \mu\text{m}$, the falling edge width at half maximum is $l_2 = 120 \pm 20 \mu\text{m}$, the full wave width at half maximum is $230 \pm 30 \mu\text{m}$.

It is shown that the velocity of the silver azide explosion wave propagation initiated by neodymium laser pulse depends on the sample cross-section gradient. If the reaction wave propagates along the direction of cross-section

decreasing the wave velocity is greater than in samples with constant cross-section. If the wave propagates along the direction of increasing cross-section it has less velocity than in an ordinary sample.

The model of branch-chain solid-state reaction propagation was suggested. It is assumed that the electron excited reaction products' deactivation in the crystal lattice leads to generation of electron excitations (chain carriers) not only in the reaction area but also in its vicinity.

The time-spatial parameters of the explosive decomposition reaction wave in silver azide were calculated in terms of the model. It was shown that the suggested model describes a number of modes including the autowave mode of the reaction propagation. The calculated values of reaction wave widths and velocity are in fare agreement with the experimental ones.

Authors thank the Russian Foundation for Basic Research for financial support (№ 11-03-00897).

SOME PROGRESS IN EXPERIMENTAL CHARACTERIZATION OF CHARGE TRANSPORT AND TRAPPING IN INSULATORS ASSOCIATED WITH SECONDARY ELECTRON EMISSION

G.Damamme, K. Zarbout¹, G. Moya², A. Si-Ahmed³

*CEA-DAM, Bruyère-le-Châtel 91297 Arpajon cedex, France,
gilles.damamme@cea.fr*

¹*LaMaCoP, Université de Sfax, BP 1171, 3000Sfax, Tunisie,
zarboutkamel@yahoo.fr*

²*Im2np, Université d'Aix-Marseille, 13397 Marseille cedex 20, France,
gerard.moya@im2np.fr*

²*Im2np, Université d'Aix-Marseille, 13397 Marseille cedex20, France,
abder.siahmed@gmail.com*

The charging of insulators is a well-known phenomenon which can have inauspicious consequences. It appears notably when mater is subject to an energetic beam, for example an electron beam.

This phenomenon can be precisely studied with an electronic microscope where we can modify the energy of the primary electron beam as their focalization. Secondary electrons created by the interaction of the primary electron beam with matter can be emitted at the sample surface. Sample can

then acquire a global charge (electrons or holes trapped) which will modify further secondary electron emission.

Using a focused beam enables one to exacerbate electron field effects and to create micro-breakdowns. On the other hand using low intensity defocused beam permits to work with a plane geometry, easier to analyze.

The essential information given by such experiments is the evolution of secondary electron emission (SEE) yield as time elapse or more precisely as charges are injected. It happens that a better parameter is the quantity of trapped charges per unit surface preferentially to the quantity of injected primary electrons.

For a large variety of materials (ceramics, glasses, polymers), the evolution of secondary electron emission and trapping is the same (in broad lines) in the diagram \log SEE yield – total trapped charge per surface unit. This diagram presents first a plateau followed by a quasi linear decrease (or increase) to a stationary state (in mean one out coming secondary electron for each incoming primary electron).

We present these diagrams for different materials with different impurity contents and different energies of primary electrons.

The initial value of SEE yield have been extensively studied and depends on a great number of parameters (energy of the incident electron beam, purity of the material, crystallographic orientation of the surface (for mono crystal as MgO).

The length of the plateau is also dependent on a great number of parameters, the previous one and also the extraction electric field used to prevent the coming back of the emitted secondary electrons towards the sample.

Incontrario the final slope proved to be independent of these various parameters, being only dependent on the material. We will comment that fact (as the other dependencies, initial value of SEE yield, length of the plateau).

This slope is different if the sample is globally positively or negatively charged. We interpret it as related to the elementary cross section of holes or trapping sites. That could be deduced by dimensional analysis or also deduced analytically from a simple modeling.

Altogether, a complete modeling able to simply describe (i.e. with a few number of parameters adapted to the few number needed to parameter the experimental results) the whole curve: a plateau followed by a quasi linear decrease, is always waiting to be forged.

**THE TRANSITION FROM SLOW DECOMPOSITION PROCESS
INTO THE SELF-ACCELERATED MODE IN THE ENERGETIC
MATERIALS**

**E. A. Grishaeva, A. V. Kalenskii, A. A. Zvekov¹, V. G. Kriger,
M. V. Ananyeva, O N. Kolmogorova**

Kemerovo State University, Kemerovo, Russia, kriger@kemsu.ru

¹*Institute of coal chemistry and materials science, Kemerovo, Russia,
Zvekov@gmail.com*

In the present paper the kinetics from slow into self-accelerated energetic materials' decomposition transition is simulated. The model combines processes which were researched earlier separately (thermo, photo-, radiochemical and explosive decomposition):

- Electron-hole pairs generation by incident irradiation and chemical reaction.

- Reaction in the anion sublattice has two stages. The first one is two holes' localization on a cation vacancy with N₆ complex formation, the second stage is N₆ complex dissociation into molecular nitrogen with releasing of a substantial amount of energy.

- Metal nanoclusters, growing according to the Mitchell's mechanism, participate in electron-hole recombination process.

The final product of the cation sublattice decomposition is thought to be 5-atom cluster; the 4-atom cluster is a center of electron and hole's recombination.

The deactivation of electron-excited nitrogen molecules in the silver azide matrix mechanism was studied; the rate constants of deactivation with electron-hole pair generation, energy transfer to a hole in the valence band and a pair of Frenkel's defects generation were estimated. The model parameters were précised with experimental data on thermolysis and ionic conductance temperature dependences at elevated pressure.

The model analysis allowed to determinate the boundaries of steadiness where the sample decomposes in the steady state regime; evaluate the conditions of the explosion propagation in accordance with heat and chain mechanisms. A special program complex for the kinetics analysis and simulation was made. The complex was used to calculate kinetic curves of initial, intermediate and final products of decomposition (22 species) in terms of full and reduced reaction mechanism; to calculate reaction rate and reaction products concentration in the steady state; to evaluate the explosion induction period.

The kinetics of silver azide decomposition under different heating rates was calculated; the conditions of self-acceleration decomposition onset under different heating and irradiation conditions were determined.

It was shown that the induction duration decreases when the temperature increase. Activation energy for the temperature range 500 - 600 K is 1.37 ± 0.02 eV. At higher temperatures the activation energy decreases to 0.2 eV. There is no stage of the substance heating in this temperature range and the chain carrier's concentration exceeds the equilibrium one which witnesses the chain nature of the explosion.

Authors thank the Russian Foundation for Basic Research for financial support (№ 11-03-00897).

LOW-TEMPERATURE STUDY OF MAGNETIC SUSCEPTIBILITY IN NONSTOICHIOMETRIC TITANIUM CARBONITRIDE

Ismatov N.B., Tashmetov M.Yu.

Institute of Nuclear Physics, Tashkent, Uzbekistan, mannab@inp.uz

It is known that magnetic susceptibility values of carbides and nitrides are less in comparison with the magnetic susceptibility of their metals. It is caused by a low electron density of carbides (nitrides) than metals. The presence of a wide homogeneity region and existence of various crystal structures signify that the magnetic susceptibilities in titanium carbides and nitrides depends from content and on character (ordering, disordering) of the carbon (nitrogen distribution in crystal lattice. The magnetic susceptibility of the III -IV group transition metal (Ti, Zr, the V, Hf, Nb, Ta) carbides and nitrides are studied generally in stoichiometric composition samples and at high temperatures with exception of some papers.

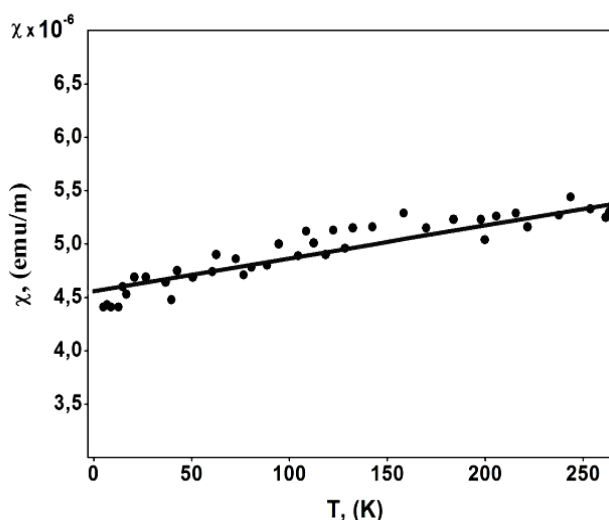

Fig.1. Magnetic susceptibility in $\text{TiC}_{0.47}\text{N}_{0.20}$

In the present work a study is carried out the magnetic susceptibility in titanium nonstoichiometric carbonitride from room temperature up to 2 K at 4 T magnetic field strength on the Model 6000 PPMS (Quantum Of design, USA) calorimetric facility. Facility is supplied by package program on control of experiment at temperature region 350 K - 0.4 K. The temperature stability is $\pm 0.2\%$ at $T \leq 10$ K and 0.02% at $T > 10$ K.

As titanium carbonitride was used $\text{TiC}_{0.47}\text{N}_{0.20}$ which prepared by self-propagating high-temperature synthesis method. The sample annealed at 1200 K - 850 K temperature region for 180 hours at high-temperature vacuum furnace for achievement of homogeneous and ordered state. X-ray diffraction study is showed that the sample is homogeneous. The existence of reflex at small angle testifies that $\text{TiC}_{0.47}\text{N}_{0.20}$ is ordered.

The results of low-temperature magnetic susceptibility in $\text{TiC}_{0.47}\text{N}_{0.20}$ are given at Fig. 1.

The temperature dependence of $\text{TiC}_{0.47}\text{N}_{0.20}$ magnetic susceptibility has linear character (Fig. 1.). However, the magnetic susceptibility is high of titanium carbonitride in comparison with titanium carbide. At substitution a part of carbon atoms by nitrogen atoms the magnetic susceptibility increases through additional valence electron collectivization of the nitrogen atom which is caused of increase of electronic states density at the Fermi level.

The present work is supported by National Scientific Fund of Switzerland (SCOPES) № IB7420-110849).

THE CRITERION OF INITIATION FOR EXPLOSIVE MATERIALS WITH THE FUSING TEMPERATURE THAT IS LESS THAN THE IGNITION TEMPERATURE BY THE SHORT LASER BEAM

A. V. Khaneft, E. V. Duginov¹, V. A. Dolgachev², G. A. Ivanov³

Kemerovo, Russia, khanef@kemsu.ru

¹ *Kemerovo, Russia, dugi_evgen@ngs.ru*

² *Kemerovo, Russia, vadimdolgachev@gmail.com*

³ *Kemerovo, Russia, indosjon@mail.ru*

The criterion of initiation for explosive materials with the fusing temperature that is less than the ignition temperature by the short laser impulse has been determined:

$$z_1 q K_0 \exp\left(-\frac{E}{k_B T_m}\right) = \lambda \frac{(T_m - T_0)}{F(\gamma)} \left(\alpha + \frac{4z_1}{r_0^2}\right), W^* = \frac{c\rho(T_m - T_0)}{\alpha(1-R)} + \frac{\rho H_f}{\alpha(1-R)},$$

where T_m is the critical temperature ignition; T_0 is the initial temperature; z_1 is the thickness of the reacting volume; q , K_0 , E are the reaction heat effect and the pre-exponential factor of the decomposition reaction and activation energy of the decomposition rate, respectively; λ , c are the heat conductivity coefficient and heat capacity of the material; ρ is the density of the material; k_B is the Boltzmann constant; α is the absorption coefficient; R is the coefficient of reflectance; H_f is the latent heat of fusion; w^* is the critical energy density of the laser pulse; r_0 is the characteristic radius of the beam; $F(\gamma) \sim 1$.

This criterion enables to explain the experiments of initiation of PETN from the open surface by laser impulse in the area of the sample transparency that depends on the diameter of the light beam [1]. The calculations coincided with the experiment results, where $\alpha = 0,064 \text{ cm}^{-1}$, and Fresnel reflection coefficient

$$R = R_F = \left(\frac{n-1}{n+1} \right)^2 = 0,036,$$

where $n = 1,47$ is the coefficient of PETN refraction.

The criterion conforms to the results of the numerical solution of the thermal conduction equation in the cylindrical coordinate system. The influence of the burning and the parameters of autocatalysis reaction (the factor of frequency and the activation energy) on the time of delay and the threshold of PETN ignition by laser impulse has been analyzed.

[1]. A.I. Bykhalo, E.V. Zhuzhukalo, N.G. Koval'skii, et al. *Fizika Goreniya Vzryva*. V. 21, No. 4, 110 (1985).

**RADIATION-THERMAL MECHANISM OF INITIATION OF
PETN IN THE ABSORPTION REGION OF THE ELECTRON PULSE**

A. V. Khaneft, G. A. Ivanov¹

*Kemerovo, Russia, khanef@kemsu.ru
¹ Kemerovo, Russia, indosjon@mail.ru*

In this work the radiation-thermal mechanism of initiation of PETN sample with an electron beam of nanosecond duration is shown. It was assumed that the electron beam energy is spend not only for heating of the sample, but also on the generation of active particles. Following stages were taken into account during the simulation of initiation of PETN:



Where A – is a molecule PETN; G – is the rate of generation of active particles; B – in absorption of the electron beam; k_1 – is the constant of the thermal production of particles B ; k'_2 – is the constant of stages of the auto-catalysis.

Taking into account the system of equations of thermoelasticity and stages (I) – (III) a mathematical model can be written:

$$\rho[c + H_f \delta(T - T_f)] \frac{\partial T}{\partial t} = \lambda \frac{\partial^2 T}{\partial x^2} - 3\alpha_t K T \frac{\partial \varepsilon}{\partial t} + (1 - f) \frac{\Lambda(x)}{R_e} I(t) + \rho Q [k_1(1 - \eta) + k_2 \eta(1 - \eta)], \quad (1)$$

$$c_s^2 \frac{\partial^2 \sigma}{\partial x^2} - \frac{\partial^2 \sigma}{\partial t^2} = 3\alpha_t K \frac{\partial^2 T}{\partial t^2},$$

(2)

$$\frac{d\eta}{dt} = \frac{G}{N_L} + k_1(1 - \eta) + k_2 \eta(1 - \eta), \quad (3)$$

where f – is the fraction of the energy of the electron beam spent on generation of active particles; N_L – is the Loschmidt constant; $\eta = [B]/N_L$; $k_2 = k'_2 N_L$; T – is the temperature; c , ρ – are heat capacity and is the density of the sample; Q – heat of reaction per unit of mass; R_e – is the electron free path length; $I(t)$ – is the energy flux density of electron beam; $\Lambda(x)$ – is the absorbed energy distribution of electron beam; c_s – is the adiabatic velocity of sound; σ – is the longitudinal stress; ε - is the longitudinal deformation; α_t – is the linear expansion coefficient; K – is the modulus of dilatation; H_f – is the latent heat of fusion; T_f – is the fusion temperature.

The system of equations was solved numerically. Calculations showed that taking into account the generation of active particles in the mechanism of initiation of PETN significantly lowers the threshold of the initiation.

THE RELAXATION OF NONEQUILIBRIUM CARRIERS OF CHARGES IN PHOTO- AND ELECTRO-RAISED OF SILVER AZIDE

V.I. Krashenin, E.G. Gazenaur, A.P. Rodzevich¹, L.V. Kuzmina,
V.G. Gritchina, E.V. Sugatov

The Kemerovo state university, Kemerovo, Russia, specproc@kemsu.ru

¹*Yurginskiy Technological Institute of the Tomsk Polytechnic University,
Yurga, Russia, nimez@rambler.ru*

This paper presents experimental results showing the existence in crystals of silver azide after the energy impact of the long-living an electron-hole plasma. Nonequilibrium solid-state plasma is formed by electrons and the holes injected in the semiconductor from contacts (contact electric field intensity - $3 \cdot 10^5$ V / m, contact material – gallium. In these conditions the mode of monopolar injection of holes is carried out. Also the source of solid-state plasma can be a radiation by ultra-violet light (UF), intensity of lighting - $1,167 \cdot 10^{15}$ quanta / (cm² c)).

Electrons and the holes generated by external power influence move one cloud.

It is shown that time of life of system of carriers of a charge - plasma of solid-state, abnormally highly and makes on experimental data from 4 to 6 minutes.

The main specific property of the plasma, allowing to speak about it as about a special condition of substance, is a collective response of particles of plasma to electromagnetic indignations.

The process of solid-phase decomposition reaction of azides takes place in areas which are localized in the places of an exit of a regional dislocation on a surface. The combination of plasma and reactionary area leads to initiation of chemical reaction.

In an anionic sublattice of silver azide reaction proceeds before formation of nitrogen, in crystal volume – before formation of an intermediate product that allows to define a spatial arrangement of plasma in crystals silver azide.

Dislocations in crystals silver azide are negatively charged and is directed are displaced on a certain distance under the influence of electric field that gives the chance to operate process of the solid-phase decomposition.

Nonequilibrium plasma in silver azide can exist in an equilibrium condition and is characterized by high degree of controllability.

SIMULATION OF FILAMENTATION OF EXTREMELY INTENSE FEMTOSECOND LASER PULSES IN CRYSTALLINE DIELECTRICS

A. V. Kuznetsov, E. F. Martynovich

Irkutsk Branch of Institute of Laser Physics SB RAS, Irkutsk, Russia, filial@ilph.irk.ru

In the course of experimental investigations of traces of filamentation of femtosecond laser pulses in photosensitive crystalline dielectrics (photosensitivity is associated with color centers formation) it was found, that the case of filamentation of train of pulses is essentially different from the case of filamentation of single pulse. For the case of train of pulses the prolongation of filaments is observed. We explain this effect with account of permanent modification of refraction index of material under the action of laser pulses: waveguides are induced in material at the location of filaments.

There are no models in known literature to describe filamentation with account of induced modifications of material. Known models describe filamentation in the «fresh» media. So, they correspond to the case of single pulse. Contrary to that, trains of many pulses are used in typical experiments.

In this work the mathematical model was developed to describe observed effect of the prolongation of filaments during irradiation of media with a number of pulses. Results of computer simulation are in qualitative agreement with experiment. Thus, it is demonstrated theoretically and experimentally that permanent modification of properties of material due to filamentation of laser pulses influences the filamentation of subsequent pulses.

INVESTIGATIONS ON PYROLYTIC DECOMPOSITION OF OIL SHALE BY THE PLASMA CHANNEL

S.M. Martemyanov, V.V. Lopatin

*Tomsk Polytechnic University, Tomsk, Russia,
sergmartemynov@mail.ru*

When an alternative high voltage affect the oil shale, except for the dielectric heating the partial discharges occur in the pores and cracks of a rock. This phenomenon initiates the development of treeing causing the formation and growth of conductive treelike discharge structure in the rock. The electrical and thermal action of the discharges in a forming dendrite causes coalification of the near discharge channels region and, as a result, the occurrence of the high-conductive areas. When the discharge structure bridges the interelectrode gap, the formed plasma channel together with the coalification area has a low resistance of 10-100 Ω per 1-cm length. The temperature of a near-channel area becomes sufficient for total pyrolytic decomposition of a rock in this region. As the rock is decomposed, the channel extends and its general resistance decreases, so it is possible to use this phenomenon for pyrolysis of a large volume of material.

Current-voltage characteristics and dependences of the electric strength on the interelectrode distance are measured which give a hope for successful realization of underground pyrolytic decomposition of oil shale.

At the moment of the formation of the plasma channel the resistance of the interelectrode distance is sharply reduced, so to heat the oil shale to a temperature of pyrolysis, it is necessary to use the generator with a sharply falling current-voltage characteristic.

DISCRETE BREATHERS ON THE 3D MODEL OF Pt_3Al WITH $L1_2$ ORDER

N. N. Medvedev, M. D. Starostenkov¹

Altay State Academy of Education, Biysk, Russia, nnm42@rambler.ru

¹ *Altay State Technical University, Barnaul, Russia, genphys@mail.ru*

A three-dimensional molecular-dynamics model of Pt_3Al with $L1_2$ order was developed and found to support the excitation of discrete breathers (DBs) on the Al sublattice. For an initial temperature of 0 K, large-amplitude DBs polarized along [100] are found to be very weakly damped, retaining most of their initial energy for more than 2000 cycles, while DBs polarized along [111] damped out over 30 cycles. DBs were excited in a considered modeling crystal at some temperature in the conditions of thermal equilibrium. Influence of trimming parameters of the used Morse potential on possibility of excitement of DBs in a modeling lattice is investigated.

MECHANISM OF THE HOT CENTERS FORMATION IN PETN MONOCRYSTALS AT THE EXPLOSION INITIATION BY HIGH-CURRENT ELECTRON BEAM

V. I. Oleshko, V. M. Lisitsyn, V.V. Lysyk, A. S. Skripin, V. P. Tsipilev

National Research Tomsk Polytechnic University, Tomsk, Russia, oleshko@tpu.ru

Two alternative mechanisms for pentaerythritoltetranitrate (PETN) initiation by high-current electron beam (HCEB) are proposed. They are electric discharge mechanism and excitonic mechanism. According to the discharge mechanism, the explosion develops from the “hot centers” which are formed in the electric discharge channels. This proposition can be proved by indirect experimental results of physical and chemical processes research in energetic materials and the results of electric discharge research in passive (non-energetic) dielectrics at the action by HCEB. Electron-hole excitation (formation of free electrons, holes and excitons) at the HCEB action is to be the key process in excitonic mechanism. Evidence of electric discharge

formation at below-threshold levels of HCEB action is to be essential to prove “electric discharge” hypothesis.

The aim of the present work is the obtaining the direct experimental evidences of electric discharge formation in PETN monocrystals and measuring the threshold of their occurrence.

It was found that crystallographically oriented streamer discharges are formed in the irradiation zone at the HCEB energy density of 0.1 J/cm². Streamers diverge at 60° and form 90° and 30° angles with crystal facets. Partial monocrystal explosion can be observed at 0.7 J/cm². Colored photos analysis shows that glow spectra for different stages of explosion are essentially different. “White” (plasma) electric discharges can be detected on the “blue” monocrystalcathodoluminescence background. The products of explosion exhibit emission predominantly in the “red” spectral range while expanding and striking on obstacles. PETN explosive decomposition products spectra are measured in the visible spectral range (400 – 700 nm) with high spectral resolution of ~ 0.2 nm. It was found that two types of glowing can be detected in PETN explosion spectra. These spectra are the nitrogen ion lines ($\lambda = 589,001$ nm and $\lambda = 589,725$ nm) and the dense low-temperature plasma glowing with continuous spectrum.

The results of the present research testify to the electric discharge model of PETN explosion initiation by HCEB. Microexplosions which occur in electric discharge localization areas disperse the monocrystal. That provokes gas-dynamic unloading of evaporation products and PETN chemical decomposition into the free space. These processes lead to expansion of non-reacted PETN. Self-propagation of the chemical reaction beyond the electron beam range (detonation of the entire explosive) occurs only for pre-dispersed PETN samples (pressed powders) when HCEB energy density exceeds threshold value.

**ATOM AND ION LUMINESCENCE OBSERVED DURING
EXPLOSION OF HEAVY METAL AZIDES IN VACUUM**

V. I. Oleshko, V.V. Lysyk

*National Research Tomsk Polytechnic University, Tomsk, Russia,
oleshko@tpu.ru*

Pulsed spectrometry with the time resolution is one of the promising methods for studying of explosive decomposition of energetic materials (EM). Laser and electron beams are used as an energy source for initiation of EM in this method. This allows obtaining of high time (~ 10 ns) and dimensional (~ 10 μm) resolution. As for the spectral resolution, it is quite low and doesn't exceed $\sim 10 - 20$ nm in the majority of publications. This makes impossible the identification of explosive products and their composition at different explosion development stages.

The presented work was aimed at measuring emission spectra observed during explosive decomposition of heavy metal azides (HMA) in visible range (400–700 nm) with a high spectral resolution (~ 0.2 nm). It is established that there are two different types of luminescence in HMA explosion spectra. The first of them is the luminescence of low-temperature plasma exhibiting a continuous spectrum. The second type is the line emission of atoms and ions being a part of EM. The strongest lines observing in emission spectra of explosive decomposition of silver azide and thallium azide are the metal atom lines Ag I (520.9 nm) and Tl I (535.046 nm) respectively. Line and continuous spectra intensity ratio depends on a mass of EM and conditions of plasma jet expansion (free expanding and interaction with an obstacle). Two densely spaced ($\Delta\lambda = 0.6$ nm) intensive emission lines are founded in the "orange" spectral range ($\lambda \approx 589-590$ nm). These lines are observed in explosion spectra of AgN_3 , TlN_3 and PbN_6 monocrystals and pressed powder compacts. Also, these lines are universal for other EM containing nitrogen. Use of atomic spectra tables allows identifying these two lines as nitrogen ion lines with the following wavelengths: $\lambda_1 = 589,001$ nm and $\lambda_2 = 589,725$ nm (with an accuracy of 0.3 nm).

**TO A QUESTION ABOUT OPTICAL PROPERTIES OF
PRESSED POWDERS OF PENTAERYTHRITOL TETRANITRATE****V. Ovchinnikov, V. Tsipilev, A. Yakovlev***Tomsk Polytechnic University, Tomsk, Russia,
vladislav_ovchin@mail.ru*

Laser radiation distribution within the volume of pressed pentaerythritoltetranitrate (PETN) pellet is required for correct study the mechanism of laser initiation of PETN. This essentiality is connected with the fact that low initiation thresholds can be obtained for laser radiation of PETN transparency spectral region. However, few researches on PETN optical properties are available. The study of the radiation distribution within the pressed powders of PETN, hexogen, and other explosives was made in [1]. Optical properties of explosives were obtained from experimentally measured diffusive reflection coefficients for explosives of different thickness. The analytical approximations of diffusive reflection coefficient functions [2] were used in [1]. However, methods [2] were unable to include low and high ordered scatterings. Aim of this research is the analysis of experimental data [1] on PETN optical properties by Monte Carlo method.

Basal optical properties of PETN voluntary unit were obtained from the curves of diffusive reflection on sample thickness. These properties are absorption index μ (cm^{-1}), diffusion index β (cm^{-1}). Increase in PETN dispersiveness results in increase both of absorption and diffusion indices. This can be partly explained by surface absorption increase.

Reflection coefficients and transmission coefficients were calculated by Monte Carlo method with μ and β indices obtained from [1]. Irradiance distribution in PETN layers was calculated as well.

It was found that calculated results with those from the experiments are different for 50 % if spherical indicatrix is used for voluntary unit description. Calculation with the prolate indicatrix showed higher accuracy (10 %). This testifies to the facts that indicatrix is prolate in powders. In addition, μ and β values measured by the method [2] contain mistakes.

[1]. A. Zinchenko, A. Pogrebov, V. Tarzhanov, B. Tokarev, Optical characteristics of some powdered high explosives, Combustion, Explosion, and Shock Waves, 1992, Vol. 28, no. 5, pp. 524 – 530

[2]. G. Rozenberg, M. Sakhalinovsky, S. Guminetskiy, Optics and Spectroscopy, 1965, Vol. 23, no. 5

SIMULATION OF RADIATION DIFFUSION IN SCATTERING MEDIA OF DIFFERENT THICKNESS

V. Ovchinnikov, A. Skripin, V. Tsipilev, A. Yakovlev

Tomsk Polytechnic University, Tomsk, Russia,
vladislav_ovchin@mail.ru

Radiation redistribution study within the volume of scattering medium of finite thickness is actual task of science. One-time diffusion theory cannot satisfactorily describe diffusion process. Integration of transport equation results in good results for turbid media and semi-infinite media with low concentration of diffusion centers. These approximations are difficult to apply for scattering media of finite thickness which has high density of scattering centers whereas they are important from principal and applied point of view.

Method with high accuracy which can simulate multiple scattering is required to study the radiation redistribution in scattering media of finite thickness more effectively than method of transport equation integration. Monte Carlo is widely used method which allows obtaining highly accurate results. However, this advantage fails to a great time required for computation.

In the research conducted the program for radiation diffusion simulation in finite thickness media is developed. The program uses Monte Carlo algorithm and it is adapted for CUDA computation. Accuracy of the results is provided by their comparison to that obtained by other methods.

Graphs of spatial irradiance on sample depth are obtained. These graphs are not continuously decrease and they have a maximum point. The dependence of maximal irradiance on input parameters (e. g. beam diameter, diffusive reflection coefficient, albedo and layer thickness) was found. It was found that spatial irradiance within the medium can exceed irradiance in incident beam if scattering rate exceeds absorption rate. It is to be noted that irradiance increase can be found even in the relatively thin layers. Graphs for irradiance distribution in the scattering layer for different indicatrix indices are obtained. They appoint on the proportional change in spatial scale of distribution on indicatrix index.

To sum up, the complicated feature of radiation distribution (irradiance maximum) in scattering medium occurs is scattering rate exceeds absorption rate. This feature can be explained by the radiation reflection from the medium/outer space boundary. Since boundary reflection change radiation distribution, it brings to irradiance increase for scattering layers with the thickness compared with photon freerun.

**DEPENDENCE OF EXPLOSION INITIATION THRESHOLD OF
PETN WITH ABSORPTIVE ADDITIVES ON UNIFORM
COMPRESSION PRESSURE OF THE SAMPLE**

V. Ovchinnikov, A. Skripin, V. Tsipilev, A. Yakovlev

Tomsk Polytechnic University, Tomsk, Russia, amosov@tpu.ru

For the first time the dependence of pure PETN powder sensitivity to laser radiation on pressure of the uniform compression of the sample was studied in [1]. A glass plate instead of one of the punches in the mould was used to initiate the sample with laser radiation. PETN pellets with ultradispersed soot (PM75 in Russian) additives were studied in [2] at the pressure of 170 MPa. Increase in PETN samples sensitivity was found in both researches.

It seems to be interesting to perform the combined research of the uniform compression pressure and soot addition effect on PETN sensitivity. As pressure grows, optical properties of PETN samples change. This changes the effect of soot addition on PETN sensitivity.

In this research the sensitivity of PETN powder with the dispersiveness of $6.000 \text{ cm}^2/\text{g}$ has been studied. The uniform pressure was changed within the range of 50 – 500 MPa and the ultradispersed soot concentration was varied within the range of 0.1 – 1 %. The research methods were similar to those described in [1, 3]. Pulsed radiation of the neodymium laser (wavelength is 1064 nm, pulse duration is 15 ns at FWHM) was focused on the sample front surface as 1 mm spot with sharp edges.

The additive effect was found to be different for different pressures. As soot concentration increased, the threshold energy density for PETN inflammation decreased by one order of magnitude and made $100 \text{ mJ}/\text{cm}^2$ for samples with 1 % concentration of additives. This decrease could be observed for uniform compression pressure $< 200 \text{ MPa}$. The threshold energy density for pure PETN pellets at pressures $> 400 \text{ MPa}$ made $200 \text{ mJ}/\text{cm}^2$. Soot addition did not essentially change the samples sensitivity since the threshold energy density decreased by 2 times only.

The results obtained coincide with the concepts described in [3], and they can be interpreted in terms of thermal microcenter theory of laser explosion initiation which is supplemented with laws of radiation diffusion in powder solids.

[1]. Yu. Karabanov, G. Afanasyev, V. Bobolev, Ignition of solid high explosives by short laser pulse, “*Goreniyekondensirovannykhsistem*” *Proceedings (Combustion of Condensed Systems)*, Chernogolovka, 1977, pp. 5 – 8

[2]. Ye. Aleksandrov, A. Voznyuk, V. Tsipilev, Effect of absorptive additives on explosives ignition by laser radiation, *Combustion, Explosion, and Shock Waves*, Vol. 26, no. 1, pp. 3 – 9

[3]. V. Tsipilev, Laser initiation of PETN, “*Fizikokhimicheskiyeprotsessy v neorganicheskikhsoyedininyakh*” *Book of Abstracts (Physical and Chemical Processes in Inorganic Compounds)*, Kemerovo, Kemerovo State University, 2001, pp. 113 – 114

FORMATION OF STRATOSPHERIC OZONE FROM CARBON DIOXIDE, AMMONIA FROM METHANE AS A RESULT OF PHOTONUCLEAR REACTIONS

E.E. Ramazanova, A.L Shabanov, M.A. Huseynov

Scientific Research Institute (SRI) Geotechnological problems of oil, gas and chemistry

Carbon dioxide reaches 97 % in Venus atmosphere according to data of interplanet space stations flights of “Venus” (USSR) and “Mariner” (USA) and it can absorb ultraviolet rays coming from sun. Here photonuclear reaction occurs.

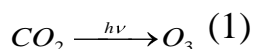

A special chemical combination - triatomic oxygen forms carbon dioxide. So, stratospheric ozone was formed under influence of solar radiation but not by photochemical way from atmospheric oxygen, it was formed from carbon dioxide as a result of photonuclear reaction.

RI Geotechnological problems of oil, gas and chemistry at State Oil Academy of Azerbaijan conducted there successful experiments on carbon dioxide utilization and receiving non-explosive and stable ozone in time. Stratospheric ozone can be used as oxidizer.

Initially fiery-liquid origin and big masses of planets-giants allowed them to live by star life for some period of time.

That's why methane gas formed near planets-giants was subjected to

double ultraviolet and infrared radiation in atmosphere from sun and hot planet-giant. This process provided methane transformation into ammonia as a result of photonuclear reaction.

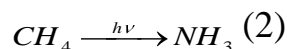

Photonuclear reaction is permanently (2).

Ammonia obtained by such way is non-explosive and can be used in fertilizers, nitrogen acid, etc. production.

[1]. Гусейнов М.А., Ахундов И.Д., Солодилов Л.Н. Фотоядерные реакции при воздействии электромагнитных излучений на парниковые газы// Геофизика XXI столетия, 2005 год. Сборник трудов Седьмых Геофизических чтений им. В.В. Федынского (2-5 марта 2005 г.) М. Научный мир, 2006 г., с. 445-449.

INITIATION OF PETN EXPLOSIVE DECOMPOSITION BY CO₂-LASER

A. Razin, A. Skripin, V. Tsipilev, A. Yakovlev, G. Damamme¹, D. Malys¹

Tomsk Polytechnic University, Tomsk, Russia, a.v.razin@mail.ru

¹ *French Alternative Energies and Atomic Energy Commission, Paris, France*

Explosive decomposition initiation of PETN pressed powder with CO₂-laser radiation ($\lambda = 10,600$ nm) of nanosecond duration ($\tau \sim 25$ ns) performed for the first time. The Initiation was possible only for samples with the surface covered with the transparent dielectric plate. The pressure of the dielectric plate is to be commensurate with the pressure in the decomposition heated center at the initial stage of its development. Therefore, gas-dynamic unloading was excluded and explosive decomposition development was facilitated. Plates of BaF₂ with the thickness of 10 mm were used as the entrance window. Plates were pressed to a experimental cell with the pressure of $2 \cdot 10^7$ N/m² with the upper piston of the hydraulic press.

Initiation thresholds were measures and the kinetics of explosive decomposition of PETN pellets was studied. Comparison of the obtained results with that for three harmonics of YAG:Nd-laser (1064 nm, 532 nm and 266 nm) [1] was made. Size effect of the threshold energy density of initia-

tion was observed. The results were compared with theoretical calculations [1].

When the sample surface was opened (uncovered), the initiation failed even for the highest level of exposure in the experiment (up to 5 J/cm^2). Sample glowing with plasma torch formation and the typical acoustic “click” could be observed if the exposure exceeded 1 J/cm^2 . Caverns were formed with the depth greater than that for radiation penetration. Caverns formation testified to partial decomposition of explosive both in the heated center and beyond it.

The results obtained in the research were discussed in terms of thermal model of focal laser initiation of explosives. The results obtained make it possible to develop the model of PETN explosion initiation mechanism in the all spectral regions and, specifically, in phonon spectral region.

[1]. V. Tsipilev, Ye. Morozova, A. Skripin, Laser initiation of PETN powder in the conditions of all-side pressure, Bulletin of the Tomsk Polytechnic University, Vol. 317, no. 4, pp. 149 – 155

INITIATION OF DETONATION OF HEAVY METALS AZIDE BY CO₂ LASER

A. Razin, V. Tsipilev, E. Morozova

Tomsk Polytechnic University, Tomsk, Russia, a.v.razin@mail.ru

The sensitivity of heavy metal azides (HMA) to laser radiation is well studied both in the transparency spectral region and the absorption region of the matrix [1]. However, no common view on the nature of laser explosion initiation is reached. Experimental data on energy thresholds and kinetic characteristics of the initiation process are needed in the phonon absorption spectral region.

Silver and lead azide samples were irradiated by CO₂ laser radiation ($\lambda = 10\ 600 \text{ nm}$, $\tau = 25 \text{ ns}$) to obtain the experimental data on laser explosion initiation in the phonon absorption spectral region. Assume that laser radiation action results in HMA oscillation and vibration levels excitation, i. e. heated center formation which is limited with laser beam diameter and radiation penetration depth.

Silver azide pellets, lead azide pellets and silver azide threadlike crystals

were tested. Initiation thresholds are measured and the dependence of the induction period of initiation on excitation pulse energy was studied.

Initiation thresholds made 0.75 J/cm^2 and 0.3 J/cm^2 for lead azide pellets and silver azide pellets, respectively. The sensitivity of threadlike crystals was lower than that for pressed pellets. Effect of beam diameter on initiation threshold was found for threadlike crystals. Comparison of obtained results with that for neodymium laser [1] was made.

Initiation thresholds coincide the theoretical calculations [2]. The results of the research can be interpreted in terms of thermal models of focal ignition of explosives.

[1]. V. Lisitsyn, V. Tsipilev, G. Damamme, D. Malys, Effect of laser radiation wavelength on the energy threshold of initiation of heavy metal azides, *Combustion, Explosion, and Shock Waves*, 2011, Vol. 47, no. 5, pp. 592 – 600

[2]. V. Tsipilev, Ye. Morozova, Ignition of the condensed substance by a laser pulse in the field of wavelengths of own absorption, *Russian Physics Journal*, Vol 47, no. 8/2, pp. 324 – 326

MICROSECOND ELECTRICAL BREAKDOWN INFLUENCE ON POLYMERIC ENERGY-INTENSIVE SYSTEMS FILLED WITH DISPERSED ALUMINUM

**D. N. Sadovnichii, Yu. M. Milekhin, S. A. Lopatkin¹, D. V. Zhgun¹,
V. F. Vazhov¹, E. A. Butenko, S. A. Malinin**

*Soyuz Federal Center of Dual-Use Technologies, Russia, Dzerzhinskii,
e-mail: fcdt@monnet.ru*

¹ *Tomsk Polytechnic University, Russia, Tomsk, e-mail: tpu@tpu.ru*

Submicrosecond electric breakdown passing through the volume of energy-intensive polymeric materials (EPM) leads to it strong mechanical destruction which is much greater than observed in non energy-intensive analogues [1]. The purpose of the present work is experimental study of impulse electrical breakdown features with a pulse of 1-26 microseconds, developing in the volume of EPM with up to 70% mass content of aluminum powder.

Arcad'ev-Marks pulsed voltage generator was used during the experiments. In the discharge circuit the following features were measured: voltage with the help of resistive divider, and amperage – by the coaxial shunt. EPM

consisting of urethane copolymer plasticized with nitroester and aluminum powder with average diameter (d) of 5 or 12 micrometers were investigated. The sample thickness was 3-5,6 mm, which is close to detonation critical diameter. The curing process was held under the conditions which exclude sedimentation of the filler.

As expected, presence of conductive particles causes a fall of electric strength, and electrical breakdown of EPM occurs at the field intensity, which is close to air breakdown in nonhomogeneous field. At the equal volume fraction of Al-powder, the electric strength is less for the EPM filled with powder of greater diameter. After the breakdown samples underwent strong mechanical destruction. Environment (water or air) does not noticeably affect the features of ongoing processes. Thus in an unfilled EPM one through crack was formed. In the sample filled with powder of $d \sim 5$ micrometers a radial-oriented crack was formed. Samples filled with the powder of $d \sim 12$ micrometers were swollen after the breakdown. Up to a maximum discharge power of 9 megawatt there was no samples ignition or explosion. Obtained results may be explained by the features of energy-release in decomposition reactions of EPM, initiated by impulse breakdown.

[1]. Sadovnichii D.N., et al. // Combustion, Explosions and Shock Waves. 2010. N4. P.464.

TO A QUESTION ABOUT PREDETONATION STAGE OF EXPLOSIVE DECOMPOSITION OF HEAVY METAL AZIDES

**V. Tsipilev, A. Razin, A. Skripin, V. Lisitsyn, G. Damamme¹,
D. Malys¹**

Tomsk Polytechnic University, Tomsk, Russia, a.v.razin@mail.ru

¹*French Alternative Energies and Atomic Energy Commission, Paris,
France*

It was studied from the numerous experiments of 50 – 60-ies that no predetonation stage could be observed in heavy metal azides (HMA). Therefore, explosive decomposition transforms into detonation immediately (without combustion stage) [1]. However, the possibility of combustion transition into detonation in HMAs is not excluded in [1] due to low spatial and time resolution of the experimental equipment. The idea that no combustion stage exists in HMAs is the common view, which is arguing.

Detection of the combustion stage can be performed using laser initiation method (provides the ability of fast heated center formation) and detecting equipment with nanosecond temporal resolution. Tracing of the explosive decomposition development is silver azide and lead azide from the 0.5 mm center is realized in this research. The center was formed by laser radiation ($\lambda = 1064$ nm, $\tau = 15$ ns).

Threadlike samples of lead azide (pressed powders) and silver azide (pressed powders and threadlike crystals) were tested. Samples were placed on the grating with the following parameters: length is 20 mm, holes period is 1 mm and the hole size is 0.1 mm. Shadow method was used to detect the explosive decomposition front edge with spatial resolution of 150 μ m and time resolution of 10 ns.

Four regimes of decomposition propagation in threadlike powders were found. The first regime corresponds to the transition from the unstable combustion to the low velocity detonation. This regime can be obtained on the first millimeter of the sample. The second regime is the low velocity detonation which can be obtained at 2 to 8 mm far from initiation place (the velocity is ~ 1.5 km/s). Third regime is the transition to the high velocity detonation. Fourth regime is the normal detonation (velocity is ~ 5 km/s). No first, second and third regime can be obtained if radiation energy density is high. Only low velocity detonation can be observed in threadlike crystals. Thus, predetonation stage of explosive decomposition can be obtained in the special initiation condition. The differences in initiation explained in terms of thermal focal ignition theory.

[1]. F. P. Bowden and A. D Yoffe, *Fast Reactions in Solids*, London, Puttersworths Scientific Publication, 1958

FTZDO EXPLOSIVE DECOMPOSITION UNDER LASER AND ELECTRON BEAM ACTION

V. Zarko^{*}, V. Oleshko, V. Tsipilev

Tomsk Polytechnic University, Tomsk, Russia

^{} Institute of Chemical Kinetics and Combustion of SB of RAS, Novosibirsk, Russia*

FTZDO is the furazano-1,2,3,4-tetrazine-1,3-dioxide which is the new class energetic material. It has high sensitivity to mechanical action which is commensurable with that for lead azide [1]. No papers on FTZTO sensitivity to laser radiation and electron beam can be found. In this research the experimental study of FTZTO behavior under laser pulse action (radiation wavelengths are 1064 nm, 532 nm, and 266 nm; pulse duration is 10 – 15 ns) and electron beam action (average energy of electrons is 300 keV, pulse duration is 25 ns).

Initiation thresholds were measured, glow kinetics and acoustic response of the samples were studied. It was found that low pressed samples (pressure increased up to 200 MPa) possess lower sensitivity (20 mJ/cm^2) than that of lead azide (10 mJ/cm^2). Initiation threshold at the electron beam action was the same for both FTZTO and lead azide and made $\sim 0.1 \text{ J/cm}^2$. Strong dependence of initiation delay time and decomposition duration on energy density of electron beam was found. As the energy density increases from 0.1 J/cm^2 to 0.8 J/cm^2 , the delay time decreases from 500 ns to 10 ns and the decomposition duration decreases from 2.5 μs to 10 ns. Further increase in energy density of the electron beam did not effect the kinetic characteristics of the initiation.

FTZTO samples with dinitrodiazapentane (DNBP) as the retardant were studied. It was found that laser initiation of FTZTO and DNBP can be occurred only if sample surface is covered with transparent plate. Initiation energy made 35 mJ/cm^2 . It is to be noted that no full decomposition could be achieved. Sample glowing could be detected if uncovered samples were tested. The intensity of the glowing sharply increased as the incident energy density increased from 0.1 mJ/cm^2 to $3,000 \text{ J/cm}^2$. Electron beam initiation threshold for FTZDO with DNBP 100 times increased if compared with that for pure FTZDO and made $\sim 50 \text{ J/cm}^2$. Crushing and expansion of the sample can be observed if energy density is varied within the ranges of $1 \text{ J/cm}^2 - 10 \text{ J/cm}^2$.

[1]. V. Tesyolkin, Mechanical sensitivity of furazano-1,2,3,4-

tetrazine-1,3-dioxide, Combustion, Explosion, and Shock Waves, 2009, Vol. 45, no. 5, pp. 632 – 633

CHARACTERIZATION OF GASE SOLID SOLUTIONS BY OPTICAL BEAMS

L.-M. Zhang¹, J. Guo¹, J.-J. Xie¹, F. Chen¹, K. Jiang¹, V.V. Atuchin²,
Yu.M. Andreev³, T.I. Izaak⁴, K.A. Kokh⁵, G.V. Lanskii³, V.F. Losev⁶,
A.V. Shaiduko³, V.A. Svetlichnyi⁴, E.A. Vaitulevich⁴

¹*Changchun Institute of Optics, Fine Mechanics and Physics, CAS,
Changchun, China*

²*Semiconductor Physics Institute of SB RAS, Novosibirsk, Russia*

³*Institute of Monitoring of Climatic and Ecological Systems of SB RAS,
Tomsk, Russia, yuandreev@yandex.ru*

⁴*Siberian Physical-Technical Institute of Tomsk State University,
Tomsk, Russia*

⁵*Institute of Geology and Mineralogy SB RAS, Novosibirsk, Russia*

⁶*High Current Electronic Institute of SB RAS, Tomsk, Russia*

The extreme optical properties GaSe is widely employed for the generation of mid-IR to THz emission by frequency conversion. On the other hand, pronounced layer structure of GaSe leads to polytypism, degraded optical properties, low hardness, easy cleavage and results in hampering of large-area crystal application. A desirable ϵ -polytype structure of GaSe is strengthened by growing of its solid solutions. Simultaneously, other physical properties responsible for the frequency conversion efficiency are also significantly modified. Unfortunately, preserved polytypism, presence of secondary phases (Ga_2Se_3 , diffused and precipitated Ga), composition variation along the growth direction, surface and bulk micro-defects (dislocations, broken layers) cause difficulties in characterization of centimeter- and micrometer-length samples by traditional methods. Improved optical properties are hard to be measured by conventional absorption spectroscopy at maximal transparency range, lattice structure by X-ray analysis, chemical composition of low mixing ratio solutions by any kind of microanalysis. That is why even positive result of the solid solution formation is still in doubt in literature. Such status quo keeps back the optimization of growth technology and maximization of the frequency conversion efficiency.

Here we pay attention to the use of optical beams for characterization of GaSe solid solutions. First, we proposed optical quality characterization by absorption spectroscopy out of the maximal transparency range by exploration of intensive exciton and phonon absorption peaks. It allows us to reach optimal 50% transparency of small length samples that is optimal for an estimation of absorption coefficient. To exclude the micro-defect influence on the measurement results we proposed to use the spectral bandwidth of these absorption peaks, ratio of exciton peak and nearby valley transparencies/absorption coefficients, inclination angle (wavelength derivative value) of the short-wavelength end of transparency diagram and transformation of phonon mode structure as indicators of optical quality. Strong correlation of narrowest spectral bandwidth, maximal ratio of intensities, maximal derivative value and absence of a transformation of phonon peak structure and optimal doping concentration was confirmed by frequency conversion into mid-IR and THz ranges. Transformation of Raman scattering line at 212 cm^{-1} was proposed as another way for identification of optimal doping. Spectral position of the short-wavelength end of the transparency diagram is also used in qualitative determination of the doping level. Comparative analysis of φ -angle dependence for I and II type interactions is proposed as an efficient method for polytype structure characterization over the crystal bulks.

Acknowledgment: SB RAS for Interdisciplinary Integrated Project No.46 of 2012.

**THE PERIODIC STRUCTURE OF COLOR CENTERS
DISTRIBUTION IN FILAMENT FORMED BY FEMTOSECOND
LASER IRRADIATION IN CRYSTAL MgF_2**

S. A. Zilov^{1,2}, E. F. Martynovich^{1,2}, L.I. Brykvina¹, A. A. Starchenko¹

¹ *Irkutsk Filial of Institute of Laser Physics SB RAS , Irkutsk, Russia,
E-mail: filial@ilph.irk.ru*

² *Institute of Applied Physics, Irkutsk State University, Irkutsk, Russia*

It is known from earlier works, irradiation of wide range of dielectrics by femtosecond laser pulses forms threadlike channels (filaments), colored centers of luminescence. For example, formation of aggregates of F_2 and F_3^+ centers in LiF crystals irradiated by femtosecond laser pulses.

In this paper, the crystal samples of MgF_2 , with pre-induced color cen-

ters (CCs), were irradiated by femtosecond pulses from a Ti: sapphire laser (pulse duration 30 fs, frequency 1 kHz, energy 0.5 mJ). The figure shows photographs of MgF₂ luminescence under excitation by light with $\lambda_{\text{ex}} = 405$ nm.

It is possible to see luminescence of some filaments has an axially periodic structure with the period $\Lambda \approx 38$ μm .

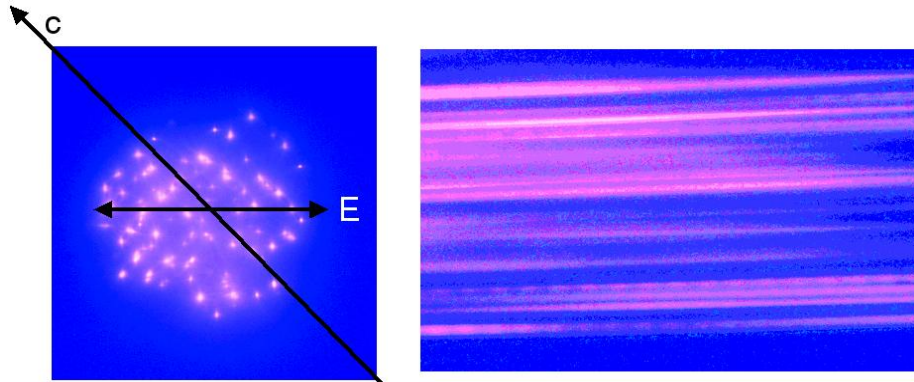

Fig. The luminescence of CCs in MgF₂.

The femtosecond laser radiation comes normal to the face of the sample and has horizontal polarization. The optical axis \mathbf{c} is oriented at an angle 45° to the vector \mathbf{E} (left).

The luminescence of the formed filaments, direction of observation is perpendicular to the lateral face of the sample (right).

The authors propose a mechanism for the formation of color centers explaining the emergence of such structures. It is shown that this structure appears due to the two-photon absorption of M (C_1) centers by irradiation of femtosecond laser and their subsequent ionization. The period $\Lambda \approx 40$ μm , calculated from the theory, is similar to observed.

**THE DEPENDENCE OF THE EXPLOSIVE DECOMPOSITION
CRITICAL ENERGY DENSITY ON PULSE DURATION**

**A. A. Zvekov¹, V. G. Kriger, A. V. Kalenskii, B. P. Aduiev,
I. Yu. Zykov, A. P. Nikitin**

Kemerovo State University, Kemerovo, Russia, kriger@kemsu.ru

¹*Institute of coal chemistry and materials science, Kemerovo, Russia,
Zvekov@gmail.com*

The paper is devoted to calculation of the critical parameters of heat explosion initiation during the laser heating of nanosized metal inclusions in energetic materials. The light absorption efficiency (Q_{abs}) of metal inclusions was taken into account in the simulation.

The dependences of explosion initiation critical energy density on the pulse duration for the different inclusions radii in the assumption of $Q_{abs}=1$ were calculated earlier. The Q_{abs} values were estimated in terms of Mie theory for silver and lead inclusions. As in the most of cases $Q_{abs}<1$ its consideration leads to increase in critical energy density values.

The explosion initiation critical energy dependence on the pulse duration ($H_r(t_i)$) for different nanosized inclusions' radii and their set were calculated taking into account the dependence of the light absorption efficiency on the radius and material of the inclusion.

The comparison of the obtained dependence $H_r(t_i)$ and the previous one indicates that $Q_{abs}(r)$ accounting leads to the relative changing in the curves calculated for the different radii positions. As $Q_{abs}(r) \rightarrow const$ when $r \rightarrow \infty$ in the range of long pulse durations the equation $H \approx const \cdot t_i^{0.4}$ is still valid. When the pulse duration is smaller than the thermal diffusion time, for inclusions with radii 50 – 80 nm (where the $Q_{abs}(r)$ has a maximum) the envelope curve tends to a constant margin $H \approx const$. The cause of such behavior is strong $Q_{abs}(r)$ decreasing in the area of $r < 70$ nm. Thus the light absorption efficiency consideration leads to effective “cut down” of the small radius region of the inclusions cumulative distribution curve. So the small radius range does not play a significant role.

The received regularities correlate with the experimental dependence for the lead azide: at small pulse durations the critical energy density tends to a constant value, in the range of greater durations the dependence tends to power dependence with the index 0.5 – 0.7.

Thus the consideration of the absorption efficiency gives the following main results:

1. The curves positions calculated for different radii change. Some of them rise when $Q_{abs} > 1$, others fall.

2. The most affected is the range of small inclusions radii when the Q_{abs} strongly tends to the zero value.

3. When the pulse duration is small the optimal inclusions radius does not depend on the pulse duration and becomes equal to the radius of the inclusion that absorbs light the most effectively. The critical energy density tends to a constant value when $t_i \rightarrow 0$.

Authors thank the Russian Foundation for Basic Research for financial support (№ 11-03-00897).

**SURFACE STRUCTURE FEATURES OF COMPOUNDS WITH
MOVEABLE METALLIC SUBLATTICE**

V.M. Berezin, A.A. Troitskiy¹

*South Ural State University (SUSU) (National Research University),
Chelyabinsk, Russian Federation, bvm@susu.ac.ru*

¹ *South Ural State University (SUSU) (National Research University),
Chelyabinsk, Russian Federation, andrei.troitskiy@gmail.com*

To a class of chemical compounds with the moveable metallic sublattice belong chalcogenides, iodides, bromides of 1B metals that possess a structural disorder and specific thermodynamic and kinematic characteristics. The most interesting of them are: anomalously high ionic and superionic conductivity, fast diffusion, all of them has been studied comprehensively. These characteristics (features) allow expecting a high rate of a depth of occurrence of radiation defects in metals on their basis.

On the basis of surface experimental researches of cuprum and silver chalcogenides we propose a surface reconstruction model that resulting in a molecule development of X_n chalcogen ($n = 2, 6, 8$ and so on) in a surface coat. This development eventually results in a changing of a metal/chalcogen stoichiometrical condition in the crystal surface coat of the compound. Experimental data on evaporation (distillation) of crystals in vacuum and magnetic susceptibility (obtained by the Faraday method) were used.

From the perspective of thermodynamics this model applicable because of a lower free energy during a formation of a chalcogen-chalcogen bond in the surface coat. But the state of the surface coat is not to be envisaged as truly equilibrium. The stationarity of the chemical composition were conducted (studied) in classical Rickert's experiments with the use of electrochemical cells. In evaporating sulphur flow (from silver sulphide) by a mass spectroscopic analysis Rickert detected molecules of distinct composition: S_2, S_6, S_8 .

The proposed model of the surface structure allows specifying a character of primary processes that take place during a interaction of beams of particles with crystals with the moveable metallic sublattice.

The proposed model conforms to the investigated phases structure (FCC - false galenite, BCC) and with reconstruction relationships of corresponding fracture faces (111) and (110).

**STIMULATED BY IONIZING RADIATION ELECTRONIC
ACCOMMODATION OF THE REACTION HEAT
IN H-ZnS, ZnS,CdS-Ag SYSTEMS**

V.P. Grankin, M.V. Grankin

*Priazovsky State Technical University, Mariupol, Ukraine,
victor.grankin@gmail.com*

Solids under effect of ionizing radiation or atoms from low-temperature plasma develop an excitation of crystal's electronic and nuclear subsystems. The main energy-release during interaction of atoms is caused by chemical transformations on the surface and is accompanied by generation of a vibration-excited molecule H_2^vL on the surface. That molecule starts in pre-dissociated state. A probability of the H_2^vL dissociation (or break-up of highly excited vibrating bonds in the solid generated by radiation) depends on the rate of the energy accommodation. A phonon channel is considered the main channel of accommodation of energy of atomic particles impacts with solid. We found [1] that relaxation of the excitations can be effectively carried out by the vibration energy accommodation via electronic channel.

Targets of the research were: ZnS,CdS-Ag and ZnS, the hydrogen was chosen as a stimulating gas. Experiments were conducted using vacuum unit described in [2]. Heterogeneous chemiluminescence (HCL), triggered by the reaction energy, served as indicator of the rate of electron accommodation. Experiments [2] showed that the intensity I_{HCL} of the ZnS,CdS-Ag sample from UV-light with flux Φ was dependent from Φ and increased by 3 orders of magnitude at $\Phi > 10^{11} \text{ cm}^{-2}\text{s}^{-1}$ in comparison with unexcited ZnS,CdS-Ag and by 5 orders of magnitude in case of ZnS monocrystal.

Model accounts for space heterogeneity of the surface in a way that adsorption and desorption processes can run on one kind of surface centers, and H_2^vL relaxation – on the other. It is possible due to the run of excited molecule by distance L from the point of its formation to the quantum centers with localized electrons. Algorithm and program for computer simulation based on Monte-Carlo method were designed.

It was found that electron channel of accommodation can be the main channel of accommodation of recombination energy of H atoms on the investigated samples if they are placed in the field of ionizing radiation. It was shown that irradiation by UV-light caused an increased reaction rate I_{HCL} but decreased L . This effect is caused by accommodation of the reaction heat via

electron channel. Areas of activation or relaxation electron catalysis were specified.

[1] V.P. Grankin, *Kinetics and Catalysis* **37**, 802 (1996).

[2] V.P. Grankin, V.Yu. Shalamov, N.K. Uzunoglu, *Chem. Phys. Lett.* **328**, 10 (2000).

CHEMILUMINESCENCE OF Zn_2SiO_4 -Mn, EXCITED BY UV-RADIATION UNDER THE INFLUENCE OF H-ATOMS WITH THERMAL ENERGY

D. V. Grankin

*Pryazovskyi State Technical University, Mariupol, Ukraine,
denis_grankin@mail.ru*

Chemical interactions of the simple gas atoms on the surface can run with high energy release per local act. This energy initially concentrated on newly formed bonds in the form of non-equilibrium vibration states, which later relax. Non-equilibrium vibration states interact with both atomic and electronic subsystems of the crystal, transferring the latter one into excited state. As a result, one can observe electron chemoemission from the surface and heterogeneous chemiluminescence (HCL).

The HCL of willemite (Zn_2SiO_4 -Mn) was investigated. It was excited in the reaction of recombination of hydrogen atoms with thermal energy at the presence of UV-light. Willemite was chosen as a sample because of its bright HCL ($\lambda_{max} = 525$ nm) in atomic hydrogen, oxygen and in atmosphere of some other radicals, has wide band-gap and a system of electron traps, which can effectively participate in accommodation of heat of heterogeneous reaction via electron channel. The hydrogen was chosen because vibration-excited molecules H_2^v formed in the reaction have the largest vibrating quanta, which makes it difficult to accommodate the vibration energy of H_2^v via phonon channel (for its large difference from the phonon's energy in Zn_2SiO_4 -Mn). It promotes an increase in probability of accommodation of reaction heat of H-atoms recombination via electron channel.

Experiments were carried out using the high-vacuum unit. Nonelectrode HF-discharge or pyrolysis source was used as a generator of H-atoms. To ir-

radiate samples with UV-light a mercury lamp was utilized. Luminescence of $\text{Zn}_2\text{SiO}_4\text{-Mn}$ was registered by photomultiplier tube through optical glass.

HCL kinetics of the electron-excited sample after enabling a flux of atoms runs through maximum and decays in due course until steady-state value I_{HCL}^∞ . The HCL intensity at the maximum $I_{\text{HCL}}^{\text{max}}$ was more than 2 orders of magnitude higher than I_{HCL}^∞ intensity. The magnitude of HCL scintillation I_{HCL}^e , which occurs during the action of the impulse flux of H-atoms on the surface, was dependent from the filling of the electron traps and raised with the increase of pre-excitation time by UV-light of the $\text{Zn}_2\text{SiO}_4\text{-Mn}$ up to some peak value at which stationary fill of the electron traps was established at given UV-light flux and sample temperature. It was obtained that the value I_{HCL}^e was high if the afterglow intensity I_{ag} was also high, defined by the concentration of electrons on the traps at the given moment of time. I_{HCL}^e was linearly proportional to I_{ag} and at the temperature of the irradiation of sample $T=300$ K it was 2 orders of magnitude higher than I_{HCL} of sample non-radiated previously by UV-light or sample with empty traps. Decrease of the temperature at which preliminary irradiation by UV-light was performed caused an effect boost.

It was found that heterogeneous recombination of H, O atoms on the surface of willemite caused an effective de-excitation of the electron traps. It was obtained that irradiation of $\text{Zn}_2\text{SiO}_4\text{-Mn}$ by UV-light from its self-absorption area caused an increased rates of accommodation of heat of the reaction of H or O atoms recombination via electron channel by more than 2 orders of magnitude. This effect is associated with a high efficiency of accommodation of the reaction energy via electron channel with participation of the electron traps.

**EFFECT OF SURFACE PASSIVATION BY HYDROGEN
TO THE STRUCTURE AND ELECTRONIC PROPERTIES
OF SILICON NANOPARTICLES**

**S.B. Khudayberganov^{1,2}, A.P. Mukhtarov^{1,2}, N.T. Sulaymanov²,
Kh.I. Akbarov¹**

¹*National University of Uzbekistan named after Mirzo Ulugbek,
Tashkent, Uzbekistan*

²*Institute of Nuclear Physics of Uzbekistan Academy Sciences,
Tashkent, Uzbekistan, sardor@inp.uz*

Over the last decade, silicon nanoparticles have been the object of intensive research worldwide due to its fluorescent properties, which can be used in monitors and biodiagnostics. It is well known that hydrogen plays an important role in the silicon electronics, affecting the structure and electrical and optical properties. Surface passivation by hydrogen atoms has the effect of freezing and can stabilize the nanostructure. In this case the atoms at the surface are tetracoordinated.

Of particular interest is the fact that the luminescent properties of nanoparticles can be controlled by changing the conditions of passivation.

In our studies, we consider clusters of Si₂₉ and Si₃₈ with a diamond-like structure. The calculations were performed using non-standard tight-binding [1]. Optimization of the geometry of the cluster by the method of stimulated annealing molecular dynamic simulations.

Investigation of the electron density of states of Si₂₉ and Si₃₈ clusters with partial and full saturation of surface dangling bonds showed that the main contribution to the density of states near the band gap of silicon atoms are given. The contribution of hydrogen atoms saturating the surface of communication, the width of the HOMO-LUMO gap is quite significant. The gap width Si₂₉ cluster with partial saturation of dangling bonds at the 20 H atoms) is equal to about 0.2 eV, followed by an increase in the number of saturating hydrogen atoms starts to increase, approaching 2.7-3.0 eV. It unsaturated bonds of the surface atoms of the cluster lead to a blurring of boundaries of the HOMO and the LUMO and the narrow gap between them. The gap width varies from cluster Si₃₈ 0.089 eV for the pure cluster to 2.5378 eV for the fully passivated clusters.

In partial passivation of the surface structure of the cluster is distorted bonds, while the total hydrogen passivation of dangling bonds on the surface stabilizes (freezes) the structure of diamond-like clusters. Similar results were

obtained for the cluster Si_{38} . The volume of hydrogen-passivity cluster dimerized $\text{Si}_{38}\text{H}_{30}$ after optimization is reduced, due to the shortening of the bond lengths between the outer Si atoms in an average of 0,015 Å, with bond lengths in the core of the cluster is almost unchanged. The lengths of the Si-H bonds increased by an average of 0,05 Å. At the same time completely unreconstructed passivated cluster $\text{Si}_{38}\text{H}_{42}$ increases in volume.

This work was supported by the FSR AS RUz and partially grants the U.S. CRDF № UZC2-2877-TA-07.

[1]. Z.M. Khakimov, P.L. Tereshchuk, N.T. Sulaymonov, F.T. Umarova, M.T. Swihart, Non-conventional tight-binding method for calculation of total energy and spectroscopic energies of atomic clusters. Phys. Rev. B. V.72. P.115335, (2005)

COMPUTER MODELING OF ATOMIC AND ELECTRONIC STRUCTURE FOR SODIUM PERCHLORATE SURFACE

D. V. Korabel'nikov

*Kemerovo State University, Kemerovo, Russia,
dkorabelnikov@yandex.ru*

The geometry and electronic structure for bulk and surface of sodium perchlorate are calculated in the gradient approximation of density functional theory, using a linear combination of atomic orbitals CRYSTAL09 code. Ab initio determination of crystal structure was carried out by minimization the total energy, interatomic forces and displacements. The surface relaxation, the surface energies, densities of states, overlap populations and atomic charges are computed within model of ultrathin films (slabs). It was found that the top layer for surface is formed by oxygen atoms that result in the activity for processes of decomposition with the oxygen emission. For the oxygen atoms of the upper layer: intra-anionic bond length is reduced comparatively to the volume, overlap populations are increasing, and the charges are reduced.

The work was supported by the project №16.740.11.0591 “Scientific and scientific-pedagogical personnel of innovative Russia (2009-2013)”

**STRUCTURE AND ELECTRONIC PROPERTIES OF THE MIXED
HYDROGEN-HYDROCARBON COATED SILICON Si_{29}
NANOPARTICLES**

**Sh. Makhkamov¹, S.B. Khudayberganov^{1,2}, A.B. Normurodov¹,
A.P. Mukhtarov^{1,2}**

¹*Institute of Nuclear Physics of Uzbekistan Academy Sciences,
Tashkent, Uzbekistan*

²*National University of Uzbekistan named after Mirzo Ulugbek,
Tashkent, Uzbekistan sardor@inp.uz*

Recently luminescent silicon nanoparticles have been widely studied based on their potential use as light emitters in displays or general illumination and as fluorescent probes for bioimaging. The origin and characteristics of their luminescence are associated not only with the nanoparticle size but also with its shape and the nature of its surface.

The diamond-like coordination of core Si atoms in small clusters can be stabilized only by termination of the dangling bonds of the surface Si atoms. The smallest (1 nm in diameter) model of blue-emitting Si particles with a diamond-like structure is an H-terminated, reconstructed Si_{24} cluster cage ($Si_5Si_{24}H_{24}$). However H-terminated clusters are rather unstable in air and will be oxidized.

An effective means of stabilizing the silicon surface and photoluminescence properties is to graft an organic monolayer onto the H-terminated surface through a hydrosilylation reaction. Organic monolayer-protected Si particles with high surface coverage of the grafted organic molecule are quite resistant to oxidation. However, when they are heated to 140° C or illuminated with 254 nm ultraviolet light for several hours, their surface is partially oxidized, while the grafted organic molecules remain intact. This ultimately results in a large blue shift in the photoluminescence emission, but the mechanism by which this occurs is not well understood.

In this report we have investigated small silicon nanoparticles containing 29 Si atoms which surface dangling bonds were saturated with the combination of the different hydrocarbon radicals such as methyl ($-CH_3$), ethyl ($-C_2H_5$), vinyl ($-CH=CH_2$), allyl ($-CH_2-CH=CH_2$) and hydrogen (H). Recently developed by us the non-conventional tight-binding method [1] was used to compute both spatial and electronic structure of these clusters.

This work was supported by Uzbek Academy Sciences Fund for Supporting Fundamental Research (№ F2-FA-F121).

[1]. Z.M. Khakimov, P.L. Tereshchuk, N.T. Sulaymonov, F.T. Umarova, M.T. Swihart, Non-conventional tight-binding method for calculation of total energy and spectroscopic energies of atomic clusters. Phys. Rev. B. V.72. P.115335, (2005)

INVESTIGATION OF STEEL SURFACE IRRADIATED BY PROTONS IN IODINE MEDIUM

**O. V. Ryaboukhin¹, S. S. Zyryanov¹, A. V. Kruzhalov¹,
F. G. Neshov¹, M. V Kuznetsov²**

¹*Ural Federal University, Ekaterinburg, Russia, ryaboukhin@mail.ru*

²*Institute of solid state chemistry, Ekaterinburg, Russia,
kuznetsov@ihim.uran.ru*

In nuclear reactors construction materials are exposed by influence of intensive ionizing radiation fields in a combination with high temperature, pressure and fission products action. Prediction of construction material degradation resulting from radiation-induced swelling, thermal expansion of fuel and corrosion is of great significance for nuclear technologies.

The investigation of nuclear reactor materials degradation requires long-term research: firstly, the experimental sample should be stored in nuclear reactor for radiation defects accumulation and after that it is necessary the time for decreasing the radioactivity level of irradiated material. So the whole time of preliminary procedure can take some years. Therefore the modeling of nuclear reactor conditions with using other types of radiation sources allows to reduce research time.

In the present work the stainless steel 1Cr18Ni10Ti (0.07 – 0,1% C, Si ≤ 0,8%, 1 – 2 % Mn, 9,0 – 11,0% Ni, S ≤ 0,02%, P ≤ 0,035%, 17,0 – 19,0% Cr and Ti ≤ 0.7 by weight) is studied. The surface of steel was modified by 5,7 MeV protons irradiation in gaseous iodine medium with $5 \cdot 10^{-6}$ g/cm³ iodine mass density. The fluence of protons was $1 \cdot 10^{16}$ cm⁻². The methods of standard Rutherford backscattering spectroscopy and X-ray photoelectron spectroscopy were used.

The thin layer (10-15 nm) of irradiated steel samples is characterized by high iodine and oxygen atomic density. Depth profiles of iodine and oxygen concentrations change from 23 to 2 at.% and from 75 to 30 at.% correspondingly. We have observed in this layer the IO₃⁻ – anion, I₂O₅ – oxide and I₂

compounds. Under the layer enriched with iodine the thin layer of oxidized Fe and Cr is determined. In deeper layers (more than 15 nm) the bonded and molecular iodine was not observed and chemical composition is similar to studied brand of stainless steel without any oxidation of metallic components.

THE NATURE OF RRL_H CENTERS AT WILLEMITE SURFACE

E. A. Sosnov, A. A. Malkov, A. A. Malygin

*Saint-Petersburg State Institute of Technology, St.Petersburg, Russia,
sosnov@lti-gti.ru*

The active development of energy-saving technologies allowed to create at a new technological level the light sources, based on luminescent materials. Thus, despite the miniaturization and design changes of lighting devices, they are based on known process of the phosphor glow in lamps with low-pressure discharge, where phosphor based on zinc orthosilicate (willemite), activated by Mn^{2+} ions used.

To protect the active sites of phosphor from the degradation under operating conditions, by Molecular Layering method the protective titanium-nitrogen-containing coatings were synthesized on the willemite surface by sequential processing (from 1 to 3 cycles) of the matrix by vapors of $TiCl_4$ and NH_3 . The chemical assembly of nanolayers was performed at $380^\circ C$ at the flow-type installation in the environment of the dried carrier gas.

To assess the protective properties of titanium-nitrogen-containing coatings the possibilities of Radical-Recombination Luminescence of hydrogen (RRL_H) produced in the high-frequency electrodeless discharge have been used. In the RRL_H spectrum of willemite there are two regions of radiation: with maximum at 520-525 nm (peak position is similar to the photoluminescence spectrum of willemite) and non-elementary broad peak with maximum at 640-700 nm.

The synthesis of ultrathin coatings on the willemite surface leads to uneven changes in the intensities of RRL_H spectra:

- In the spectral region of 500-550 nm after synthesis of first monolayer was observed the decrease the luminescence intensity in the ~ 10 -fold.
- In the region 600-750 nm after the formation of first monolayer a decrease in the intensity of RRL_H by $\sim 25\%$ observed. During the further growth of protective coating the band does not change its intensity.

For identification of RRL_H centers of willemite the mathematical processing of spectra by Tikhonov regularization using the discrete Fourier transform was carried out. In the RRL_H spectra of willemite was identified two groups of spectral bands:

- = 528, 546 and 605 nm ($E = 2.04\text{-}2.38$ eV), - are □ With maxima at 520-600 nm (the components of the willemite photoluminescence peak.

- At = 636, 663, 680 and 720 nm ($E = 1.72\text{-}1.98$ eV), which can be □ 620-720 nm (associated with the luminescence of ≡Si-O• radicals, formed on the willemite surface at rupture of deformed ≡Si-O-Si≡ chemical bonds under the influence of the flow of hydrogen radicals.

Work was supported by RFBR (grants Nos. 10-03-00658, 11-03-00397 & 11-03-12040).

STRUCTURE-PHASE STATE OF TIZRSIN THIN FILMS IRRADIATED BY HYDROGEN AND XENON IONS.

V.V. Uglov, G. Abadias¹, A. Michel¹, S.V. Zlotski, N.A. Dolgolevich, I.A. Saladukhin

Belarusian State University, Minsk, Belarus, Uglov@bsu.by

¹*University of Poitiers, Poitiers, France,*

gregory.abadias@univ-poitiers.fr

Nanocomposite coatings have generated a great deal of interest in recent years due to their unusual and unique properties, most notably their extremely high hardness, increased wear resistance and improved thermal stability compared to mononitride. The nanocrystalline structure of the coating is promising material for nuclear reactor due to its radiation stability connected with the extended grain boundaries acting as sinks of defects.

The effects of irradiation (30 keV molecular H₂⁺ and 180 keV Xe²⁺, doses 1·10¹⁶ cm⁻² and 5·10¹⁶ cm⁻²) on the structure and phase composition of the nanocomposite thin (300 nm) films (Ti,Zr)_{100-x}Si_xN (silicon concentration x≤21.8 at.%) were studied. Coatings are two-phase systems containing substitutional solid solution c-(Ti,Zr)N (NaCl structure) with a preferred orientation (200) and the amorphous phase a-Si₃N₄.

In the case of irradiation by H₂⁺ structure and phase composition of coatings don't change (the formation of new phases and destruction of existing ones didn't detect), which reflect a high stability of structure and phase composition of the coatings under this regime of irradiation. The c-(Ti,Zr)N lattice parameter (x≤13.5 at.%) increases with irradiation, which can be ex-

plained by accumulation of radiation defects and their complexes in the coatings.

The change of the structure from X-ray amorphous ($x=21.8$ at.%) to nanocrystalline under irradiation by Xe^{2+} ions was revealed while no change of the nanocrystalline structure (grain size 10-4 nm ($x=6.5-13.5$ at.%) was found. The phase composition changes under irradiation were carried out. At dose $5 \cdot 10^{16} \text{ cm}^{-2}$ ($x \leq 21.8$ at.%) there is a partial crystallization of $\alpha\text{-Si}_3\text{N}_4$ and formation of $\alpha\text{-Si}_3\text{N}_4$ phase. In the amorphous coatings at dose $1 \cdot 10^{16} \text{ cm}^{-2}$, the formation of solid solution $c\text{-(Ti,Zr)N}$ takes place along with the existence of amorphous phases. During irradiation the $c\text{-(Ti,Zr)N}$ lattice parameter ($x \leq 21.8$ at.%) decreases due to radiation-induced annealing of point defects as well as redistribution of the solid solution atoms in the atomic collisions cascade.

Mechanisms of crystallization of amorphous phase under the irradiation by Xe^{2+} ions are discussed

THERMAL STABILIZATION OF FESN-/ α -FE(SN) LAYERED SYSTEM

A. K. Zhubaev

Aktobe State University, Aktobe, Kazakhstan, mosslab.kz@km.ru

In the present work the investigations of thermally induced processes of phase formation in two-layered systems Sn(4 μm) – Fe(10 μm), obtained by ion-plasma sputtering; have been carried out by methods of Mössbauer spectroscopy at ^{119}Sn and ^{57}Fe nuclei.

Tin layers were deposited on one side of prepared Armco Iron foils by magnetron sputtering. The thickness of layers was chose so as average values of Tin atoms volume concentrations are situated in two-phase regions of phase diagram, which include $\alpha\text{-Fe(Sn)}$ solid solution and intermetallide. Prepared samples were subjected to subsequent isothermal annealing in vacuum at 550°C temperature with duration up to 20 h. ^{119}Sn and ^{57}Fe Mössbauer transmission measurements at room temperature have been carried out. Fitting of experimental spectra were spent by methods of model decoding of spectra (for ^{119}Sn) and restitution of distribution functions of hyperfine parameters of partial spectra (for ^{57}Fe), realized in program complex MSTools.

Model identification of some spectra consists of several stages. Using a priori information about the characteristics of ground state and excited state

of ^{119}Sn nucleus, the characteristics of Mossbauer transition, sizes and directions of magnetic field H_n , the tensor of electric field gradient $\{V_{ij}\}$, asymmetry parameter η and three angles (α, β, γ) for orientation of tensor in the frame of reference, the partial spectrum of Tin atoms was simulated. The values of energies and relative intensities of transitions were calculated. The parameters of spectrum – the positions and amplitudes of hyperfine structure – were computed by HAMILTON code.

As the result of spent examinations the formation of FeSn intermetallide and solid solution $\alpha\text{-Fe(Sn)}$ was established. The dependence of the relative intensities of the partial spectra for different phases (the dependence of the relative content of phases in Tin and Iron atomic rate) versus time of the thermal annealing was obtained. It is revealed that the experimentally obtained relative ratio of the phases conforms to the calculated data.

STUDY OF THERMAL STABILIZATION IN ZR–FE LAYERED SYSTEM

A. K. Zhubaev, G. M. Mailybaeva

Aktobe State University, Aktobe, Kazakhstan, mila_26.05.89@mail.ru

In the present work the investigations of thermally induced processes of phase formation in two-layered systems Zr(2 μm) – Fe(10 μm), obtained by ion-plasma sputtering; have been carried out by methods of Mössbauer spectroscopy at ^{57}Fe nuclei.

The application of a zirconium coating 2 μm thick onto a substrate of $\alpha\text{-Fe}$ was performed on a Argamak unit (Institute of Nuclear Physics, National Nuclear Center, Republic of Kazakhstan) employing the method of ion-plasma sputtering. The substrates were prepared from a bar of Armco iron (99,8% Fe) by rolling to a thickness of ~ 10 μm using special rollers, with subsequent homogenizing annealing at a temperature 850°C for 3 h.

Sequential isothermal annealing at 900°C with a duration up to 35 h were carried out in a vacuum furnace with a residual pressure of 6×10^{-6} mm Hg. ^{57}Fe Mössbauer transmission measurements at room temperature have performed. $^{57}\text{Co(Rh)}$ with an activity of ~ 30 μCi served as a source of γ quanta. Fitting of experimental spectra were spent by method of restitution of distribution functions of hyperfine parameters of partial spectra, realized in program complex MSTools. The X-ray phase analysis of the samples was performed on a D8 ADVANCE diffractometer in a CuK_α . The measurements were conducted in the Bragg-Brentano geometry on both sides of the sample.

As the result of spent examinations the sequence of the phase transformations in the layered Zr(2 μm) – Fe(10 μm) system was established. The relative content of the phases that are formed in the bulk and in the near-surface layer of the sample was found at each stage of annealing. The process of thermal stabilization of the Fe₃Zr intermetallide at the surface and of the solid solution of α -Fe(Zr) in the bulk of the sample was realized.

THE EFFECTS OF SILICON CARBIDE RATIO AND IRRADIATION DOSE ON BORON CARBIDE-SILICON CARBIDE COMPOSITES

V. V. Uglov¹, B. Buyuk², A. B. Tugrul², S.V. Lastovski³, A.O. Addemir⁴, Yu. V. Bogatyrev³, S.V. Zlotski¹, V.I. Shymanski¹

¹ *Belarusian State University, Minsk, Belarus, uglov@bsu.by*

² *Istanbul Technical University, Energy Institute, Istanbul, Turkey, buyukbu@itu.edu.tr, beril@itu.edu.tr*

³ *SSPA, Scientific and Practical Materials Research Centre of NAS of Belarus, Minsk, Belarus, lastov@ifftp.bas-net.by*

⁴ *Istanbul Technical University, Materials Science and Engineering Faculty, Istanbul, Turkey, addemir@itu.edu.tr*

The wide using area of boron compounds in nuclear technology has generated interest to irradiation effect mechanism in boron compounds. In this study boron carbide-silicon carbide composites were irradiated by electrons. The effects of irradiation on boron carbide-silicon carbide composites were carried out.

Boron carbide-silicon carbide composites were produced by hot pressing method at different boron carbide-silicon carbide ratios. The production realized at 2250 °C temperature under 130 MPa pressure for 2 hours. The ratios of silicon carbide in the composites are up to 40 % by volume.

The boron carbide-silicon carbide composite materials were irradiated by 4 MeV electrons which influence up to 10¹⁷ cm⁻² at room temperature.

For the initial and irradiated samples XRD, SEM and EDX analyses were performed. The parameters of crystalline lattices and stresses were investigated for boron carbide and silicon carbide at each dose value and silicon carbide ratio.

The structure features of boron carbide, silicon carbide, were carried out. The effects of dose and titanium diboride ratio on the crystalline lattice parameters and stresses (micro and macro) were discussed. We also discussed possible mechanism of accumulation and evaluation radiation defects by high energy electron irradiation.

THE INFLUENCE OF ELECTRON IRRADIATION ON THE STRUCTURE OF NANOSIZED METAL PARTICLES

**B.A. Aliev, M.Zh. Buranbaev, U.P. Koztaeva, G.Partizan,
Zh. Entibekov, Zh. Nakysbekov**

*Scientific-Research Institute of Experimental and Theoretical Physics
Al-Farabi Kazakh National University, 050040 Almaty, Kazakhstan*

The structure of nano-sized copper powders, before and after irradiation with high-energy electrons in the dose range 1-10 Mrad has been studied using the methods of electron microscopy, small-angle X-ray scattering and X-ray photography. New structural phases with different lattice types and parameters have been detected.

ON THE NATURE OF COLOR CENTERS IN OPTIC FIBERS AT LOW TEMPERATURES

Amonov M.Z.

Institute of Nuclear Physics AS RU, Tashkent, muxtor61@rambler.ru

Short-living and stationary color centers are studied in FVP-300 type optic fibers (OF) with concentrations of OH ~1000 ppm. The studies showed that at room temperatures under irradiation with doses of 10^5 Rad the color centers are not formed. Under γ - irradiation at 77 K one can observe formation of color centers at 215, 260, 330 and 550 nm.

Therefore, we have proposed that under irradiation with 10^5 Rad the color centers corresponding to the non-bridge oxygen atoms are not formed. The research showed that the absorption band corresponding to the absorption of E' - centers (215 nm) disappears in two stages.

The first E' - centers disappear at 85 K, whereas the second one at > 300 K. Here, the first E' - centers disappears by luminescence, and thus in the luminescence spectrum one can see luminescence bands at 470 and 500 nm.

Based on the stated above results, we assume that those centers do appear in the optic fibers at the concentration of OH at 1000 ppm. Thus, new phenomenon was observed at temperatures of 77 - 300 K, i.e. existence of two types of E' - color centers, one of which disappears at temperatures up to

88 K, and the second one disappears at temperatures higher than 300 K without luminescence.

RADIATION OPTIC PROPERTIES OF ZrO₂-Y₂O₃ CRYSTALS EXPOSED OXIDATION RECOVER INFLUENCES

Amonov M.Z.

Institute of Nuclear Physics AS RU, Tashkent, muxtor61@rambler.ru

Spectra of absorption, photo and thermo-luminescence of crystals ZrO₂-Y₂O₃ (12 weight %) at controlled change of defect structure with the help of the nuclear particle influence and high-temperature thermo-treatment in the oxidation and recover conditions are studied. γ -irradiation reveals a thermo-luminescence (TL) pick at 280 K and a band at 530 nm connected with the releasing electrons and oxygen vacancies.

It is shown that intensities of the picks and bands of TL increase proportional to the fluence of neutrons from 10^{16} up to $2 \cdot 10^{17}$ n/cm² after irradiation crystals by fast neutrons and gamma-ray. Further increasing of fluence leads to the occurrence of a 500 nm absorption band which absorbs the absorption band of 530 nm TL and causes decrease of the pick intensity of TL which is proportional to the fluence.

High-temperature treatment of non-irradiated samples at 1300 K in the vacuum leads to the insignificant incensement of the pick and band of TL. Comparison of the results neutron influence and high-temperature annealing in the vacuum and air indicates that the pick and band of TL and absorption can be connected with F⁺- and F-like centers.

Study of high temperature dependence of the band 530 nm allowed us to consider some mechanisms of excitation of luminescence of F-like centers in ZrO₂-Y₂O₃. At 280 K this band probably connected with luminescence capture when electrons release from the trap and through the conductivity zone fall on the F-like center excited level with the further irradiation relaxation to the ground state. It was noted that burning of the band in the gamma-luminescence (GL) above 180 K simultaneously with quenching the GL 480 nm band which as is established caused irradiative decay of auto-localized excitons (ALE) which are formed at the time of recombination of electrons with (auto) localized in the lattice with the hole which is stable up to 180 K.

**RADIATION STIMULATED FORMATION OF DEFECT AND
MASS SPREAD IN ZrO₂-Y₂O₃P****Amonov M.Z.***Institute of Nuclear Physics AS RU, Tashkent, muxtor61@rambler.ru*

The firm Solution of ZrO₂-Y₂O₃ was intensively investigated, as it has a lot of industrial applications in firm electrolyts for fuel cells, sensors of gas of oxygen and others. A key to these applications - high mobility of ions of oxygen because of big concentration of vacancies of oxygen. Present work is devoted to studying an origin of the defects compelled by radiation and effects of influence of nuclear radiation on oxygen ions thermal distribution to ZrO₂-Y₂O₃ crystals. Due to high transparency of ZrO₂-Y₂O₃ of wholesale crystals indirect, but simple indirect, but simple and sensitive optical methods are acceptable to understand such researches.

Vacancies of oxygen play a fundamental role as the predecessor of electronic defects which can be created every time when electrons are mobilized in a crystal, as a result of a exposing of nuclear radiation. So that it is possible to observe wealth effects, in specific absorption and after luminescence (AL) which is indicative of presence of vacancies of oxygen. Change of intensity of character of L peak in 280 K connected with vacancies of oxygen is defined to be creation of change of concentration of oxygen.

Kinetic studying of a property showed that influence of nuclear radiation during the thermal anneals in oxidation of the surrounding atmosphere inconsolable norm of distribution of oxygen of entrances because of fall of height of a barrier of energy. Thermal processing without beam influence shows that concentration of vacancy of oxygen reduces monotonously with annealing of temperature increase while beam influence bear from temperature dependence, shows extreme character with a minimum in 700 K. Two parallel presses, apparently, takes place. Distribution of oxygen dominates in lower temperature range while radiation stimulated formation of vacancies of oxygen prevails in more high temperatures because of not radiating relaxation of peculiar electronic excitement.

**STUDY OF RADIATION OPTIC CHARACTERISTICS OF
MONO-CRYSTALS OF SILICATE AND GADOLINIUM.**

Amonov M. Z., Ahsurov M. Kh., Nuritdinov I., Saidakhmedov K.

Institute of Nuclear Physics AS RU, Tashkent, muxtor61@rambler.ru

Silicates of rare-earth elements have been widely using as detectors in the physics of high energy recent years. In the present work influence of the high temperature treatment on the mono-crystals of $Gd_2SiO_5(Ce)$, (GSO) with the mixture of cerium (concentration Ce, mol 0.5%) has been studied by the methods of thermo-luminescence (TL) and absorption band (AB). ABs with maximum at 209, 220, 245, 270-300 and 350 nm are observed in the AB after γ -irradiation in the UV region and in the visible region separate ABs are not observed excluding insignificant incensement. Picks with maximums 353, 383, 448 and 558 K are observed in the curves of TL after γ - irradiation (10^6 R).

Samples are exposed oxidation-recover annealing for the explanation of the nature of the traps in the curves of TL. After oxidation annealing and the further γ -irradiation increasing of all picks of TL is observed. Further thermo-treatment in the oxidation environment of samples in the preliminarily recovered graphite decreases the intensity of picks of TL.

Results of thermo-treatment in the different environments showed that the capture centers in the crystals GSO have electronic type traps Determination of energetic depth - E_3 according to the formula of Urbakh $E_3=T,K/500$ gave following values of picks: pick at 353 K has 0,7 eV, 383 K-0.77 eV 448 K-0.896 eV and pick at 553 K has 1,12 eV.

**FIRMNESS OF LIGHT-EMITTING DIODES FOR THE
SUPERFICIAL INSTALLATION OF WHITE COLOUR
OF THE LUMINESCENCE TO ACTION OF FACTORS
OF RADIATIVE ACTION**

**I.A.Asanov¹, A.A.Vilisov², A.V.Gradoboev³, V.S.Soldatkin⁴,
K.V.Tepljakov⁵**

¹*Open Society «Scientific research institute of semiconductor devices»
Tomsk, Russia*

²*National Research Tomsk Polytechnical University, Tomsk State University
of Control systems and Radio electronics, Tomsk, Russia, vilisovaa@mail.ru*

³*National Research Tomsk Polytechnical University, Open Society «Scientific
research institute of semiconductor devices» Tomsk, Russia,
gradoboev1@mail.ru*

⁴*Open Society «Scientific research institute of semiconductor devices»,
Tomsk State University of Control systems and Radio electronics, Tomsk,
Russia, issledowatel86@mail.ru*

⁴*Open Society «Scientific research institute of semiconductor devices»
Tomsk, Russia, rjcnz-nuts@rambler.ru*

It is known that display of light-emitting diodes for the superficial installation are demanded in great demand in the market of the radio-electronic industry. It is caused by their suitability to the automated makingup and installation [1]. As the given light-emitting diodes and products on their bottom are suitable to application in special fields of technics. Light-emitting diodes are mastered serially and have transited the full complex of trials for action of mechanical, climatic, biological factors and special mediums [2]. But, the information on firmness of light-emitting diodes is necessary for a series of special applications to action of special factors.

The construction of display light-emitting diodes for the superficial installation represents the semiconductor crystal (chip) installed in a mirror of the plastic case with the sizes 3.5×2.8 mm and hermetically sealed elastic, on the basis of silicone, transparent optical coating. For reception of white colour of a luminescence in optical coating the photoluminophor radiating in field of an optical spectrum of 530-640 nanometers is added. Examinations of light-emitting diodes of white colour of a luminescence with two structurally various types of crystals are conducted

Semiconductor crystal were prepared a substrate from silicon carbide. The active layer of a crystal is executed in the form of five quantum holes

GaN/InGaN. A direct current is 20 mA, optical power is 20 mW, a maximum of a wave length is of 460 nanometers, direct a voltage is 3.2 V. Semiconductor crystal made on lift-off of technology. The active structure GaN/InGaN grown up on a sapphire substrate separates on technology lift-off from sapphire and is transferred on a copper substrate. It provides effective heat removal from the active field of a crystal. At a direct current is 20 mA, the voltage is 3.2 In a crystal radiates is 24 mW optical power in a spectrum of 460 nanometers.

Thus, effects of trials have shown that the given light-emitting diodes are proof to action by an irradiation by prompt neutrons with fluence 5×10^{13} . The odds of values after trials for light-emitting diodes with crystals on carbide of silicon and with crystals on a copper substrate can be caused features of manufacturing techniques of crystals, their level of a doping their magnesium and silicon for pinch of number of charge carriers in n and p semiconductor fields. That fact that there are catastrophic failures at light-emitting diodes in process and after trials, and as degradation after action спец is important. Factors on light options has not exceeded 30 % from initiating value (before trials).

Operation is executed with financial support of Federal Target Program, ГК № 516.11.6100

The literature list:

1. A.A.Vilisov, V.V.Dohturov, V.S.Soldatkin, K.V.Tepljakov Display light-emitting diodes for the superficial installation//: Semiconductor light engineering - 2011 - № 5.
2. A.V.Gradoboev, I.A.Asanov, I.M.Skakova Firmness of light-emitting diodes on the basis of InGaN/GaN at an irradiation prompt neutrons and gamma-quantums//Nitrides of gallium, indium and aluminium - structures and devices: Works of 8th All-Russia conference. - St.-Petersburg, 2011 - with. 100-102.

THERMOLUMINESCENCE PROPERTIES OF LITHIUM HAFNATE

Ya. V. Baklanova, A. V. Ishchenko¹, T. A. Denisova,
L. G. Maksimova, B. V. Shulgin¹, V. V. Yagodin¹

Institute of solid state chemistry of Ural branch of Russian Academy of Sciences, Yekaterinburg, Russia, baklanovay@ihim.uran.ru

¹*Ural Federal University named after the first President of Russia B.N.Yeltsin, Yekaterinburg, Russia, a-v-i@mail.ru*

Compositions based on hafnium oxide and hafnates possessing photo-, X-ray, and radioluminescence have attracted significant interest as multi-purpose optical materials [1, 2].

The fine dispersed powder (the average grain size 0.2 and 1.5 μm) of lithium hafnate Li_2HfO_3 has been synthesized by citrate technique. The photo- and radioluminescence properties of lithium hafnate have been described early [3]. The thermoluminescence properties of Li_2HfO_3 are presented in this report. The hafnates Li_2HfO_3 have been investigated after irradiated x-ray beam (40 kV) for 5 minutes. The glow curves were measured at 90–300 K (Fig. 1) and 300–500 K (Fig. 2) temperature ranges. The thermoluminescence curves contain three main bands at 130, 250 and 450 K. The calculations of traps energy, frequency factor and other parameters of trap centers were performed by approximation experimental results in terms of May-Partridge model using general order equation and integral approximation.

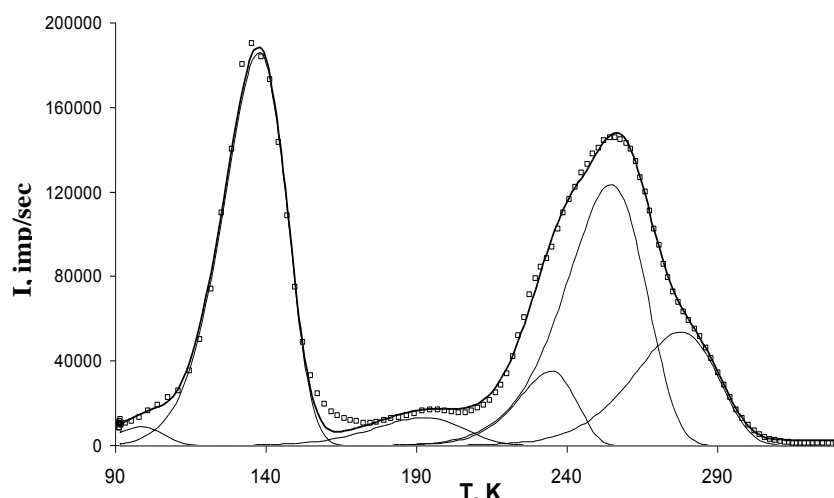

Fig. 1. TSL curve of Li_2HfO_3 in the 90–300 K range

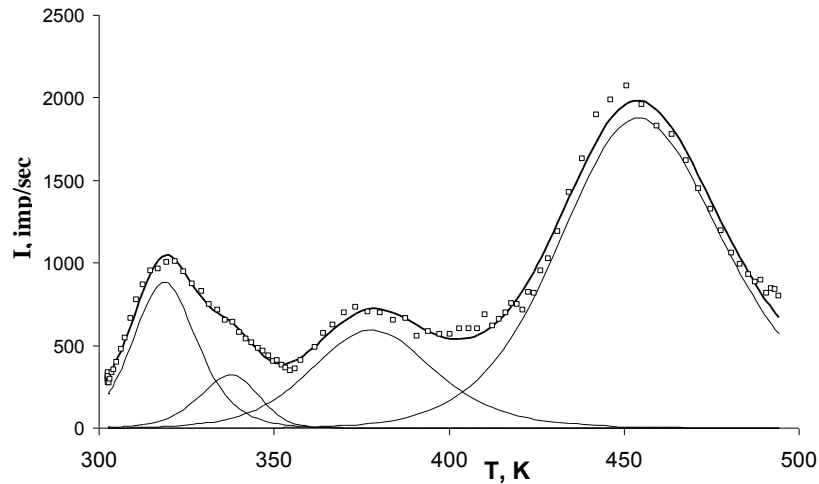

Fig. 2. TSL curve of Li_2HfO_3 in the 300–500 K range

As a result of the analysis of glow curves one can see that the kinetic process order in the 90–300 K range is first one. The order of kinetic in the 300–500 K range is second one. It can be indicate that there are two types of trap centers in fine dispersed lithium hafnate.

The work was supported by state contract in the framework of federal special-purpose program “Scientific and research and educational cadres of innovation Russia” (2009–2013), the grant N 12-03-00377 of Russian Foundation for Basic Research and the grant N 12-T-3-1009 of the Ural Branch of RAS.

[1]. Aleksandrov V.I., Voronko Yu.K. et al., DAN SSSR 199 (1971) 1282–1283.

[2]. Bryan P.S., Lambert P.M., Towers C.M., Jarrold G.S., US Patent 4988880, 1989.

[3]. Baklanova Ya.V., Ishchenko A.V., Denisova T.A., Maksimova L.G., Shulgin B.V., Pustovarov V.A., Viktorov L.V. Photo- and radioluminescence of lithium hafnate // *Optical Materials*, 2012. Vol. 34. Is. 7. P. 1037–1041.

APPLICATION OF ELECTRON ACCELERATORS FOR X-RAY FLUORESCENCE ELEMENT ANALYSIS

V. I. Bepalov, Yu. F. Krechetov, S. E. Lazarenko, E. N. Shuvalov,
S. R. Uglov

*Tomsk Polytechnic University, Institute of Physics and Technology,
Tomsk, Russia, krechetov@tpu.ru*

An X-ray fluorescence (XRF) spectrometry is good method used for routine, relatively non-destructive chemical analyses of rocks, minerals, sediments and fluids. The relative ease and low cost of sample preparation, and the stability and ease of use of x-ray energydispersive (ED)spectrometers make this one of the most widely used methods for analysis of major and trace elements.

In the ED XRF analysis we suggest to use electron beams with energy of some MeV. Accelerators of electrons of direct action, in particular Van de Graaf's electrostatic generators are the most suitable.

Calculations of bremsstrahlung photons spectra from electrons with energy up to 6 MEV, leaving a sample and characteristic x-ray radiation (CXR) are executed by the Monte-Carlo method according to the program «Computer laboratory» [1]. The evident advantage of use of a electron beam for the XRF analysis of averages and heavy elements is shown at interaction of electrons directly with sample passing a stage of photon beam receiving.

On the microtron and the electrostatic generator ESG-2.5 of Institute of Physics and Technology TPU are measured the CXR spectra by interaction of electrons with several targets. The X-rays generated in the target were detected by a CdTe semiconductor detector with sizes of crystal 2x2x2 mm³ (Model 100 TD, AMPTEK Inc.). Good extraction of K-lines of CXR of heavy elements over a background was observed. The yields of CXR within experimental uncertainties will be agreed with Monte-Carlo data. It allows possibilities of the «Computer laboratory» program to use for development of XRF analysis on electron accelerators.

[1] Bepalov. Interaction of ionization radiations with medium. Issue 4. Tomsk Polytechnic University. 2008, 368 p.

**AGGREGATION AND TRANSFORMATION OF COLOR
CENTERS UNDER Γ AND LASER RADIATION IN
MAGNESIUM FLUORIDE**

L. I. Bryukvina, A. L. Rakevich¹, E. F. Martynovich¹

*Irkutsk Branch of the Institute of Laser Physics SB RAS, Irkutsk, Russia,
baikal@ilph.irk.ru*

¹ *Irkutsk Branch of the Institute of Laser Physics SB RAS, Irkutsk, Russia,
femto@bk.ru*

The crystals of magnesium fluoride (MgF_2) are used as materials of optical elements and devices (windows, lens, etc.) thanks to wide area of transparency (0,11÷7 micron) and radiating stability. In recent years powerful laser sources, including femtosecond laser, are actively used that stimulates researchers to check stability of optical windows, lenses and other devices to powerful radiation.

It is considered that in magnesium fluoride under the influence of a various type of radiations (x-ray, γ - quanta, electronic and ionic beams and others) aren't formed the electronic charged and neutral aggregate color centers (CCs), consisting from more, than two, anion vacancies. However, our researches show formation of the new CCs with luminescence in area, much more long-wave, than for F_2 centers, in γ -irradiated MgF_2 crystals.

Owing to treatment by femtosecond laser radiation of γ -irradiated ($5 \cdot 10^7$ R) magnesium fluoride occurs a significant increase in concentration of CCs, both known, and new, in created spurs (the colored filaments with CCs) in comparison with an initial crystal. Distinctions in creation and transformation of CCs in spurs, parallel and perpendicular to an optical axis of a crystal, respectively, are observed.

The research of a photoluminescence of CCs along cross-section of spur shows higher efficiency of creation of CCs in the center spur. In peripheral parts of spur, induced by femtosecond impulses, is observe weaker luminescence of CCs, than in a matrix of γ -irradiated crystal outside of spur. It testifies to CCs decolouration in a peripheral ring of cross-section of spur by the supercontinuum radiation, created by femtosecond impulses. In spur the luminescence of new CCs is fixed and lengths of waves and decay times of luminescence are defined: $\lambda_{1\max}=656$ nm, $\tau_1=15\pm 0,5$ ns; $\lambda_2=810$ nm, $\tau_2=23\pm 0,5$ ns. CCs distribution on spur cross-section characterizes energy distribution on a cross-section profile of a filament of a femtosecond beam.

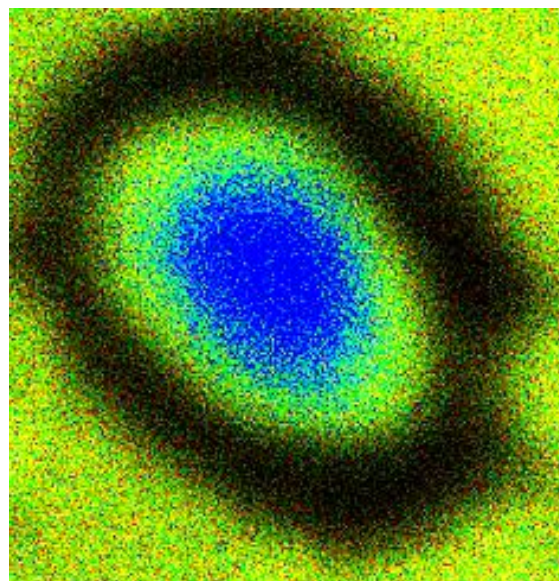

The image of spur cross-section, received by means of a confocal microscope Micro Time 200. Average diameter of spur 20 microns.

The investigation was carried out in the the framework of the scientific project of the Program of fundamental researches of Presidium RAS № 13.12 and the scientific project of the Program of SB RAS № II.8.1.6.

**LUMINESCENT PROPERTIES OF NANOSTRUCTURED FILMS
BASED ON LITHIUM FLUORIDE OBTAINED BY THE METHODS
OF LASER TECHNOLOGY**

V.P. Dresvyanskiy, A.L. Rakevich, S.N. Malov, E.F. Martynovich

*Irkutsk Branch of Institute of Laser Physics SB RAS, Irkutsk, Russia, fil-
ial@ilph.irk.ru*

The nano-structured film samples were prepared on the basis of lithium fluoride with thickness of 2-20 microns on glass substrates. We investigated experimentally the structure of the films, the spectra and kinetics of luminescence using a confocal scanning time-resolved microscope MicroTime 200 with the spectrometer Ocean Optics QE65000. The luminescence spectra were measured under excitation by laser radiation with a wavelength of 375 nm, 405 nm, 470 nm and 532 nm. To suppress scattered by a sample of the exciting radiation luminescence is recorded through filters with a cutoff wavelength of 400 nm, 430 nm, 500 nm and 550 nm, respectively. Then these samples were exposed to X-ray study for 45 minutes ($I = 15$ mA, $U = 15$ kV), after which the studies were carried out luminescence centers induced by radiation.

Studies have shown that the films contain a luminescent grain with size of 200-300 nm, observed at the limit of spatial resolution of the microscope. When excited by each of these lasers in non-irradiated samples were observed weak non-elementary luminescence bands with maxima at 400 nm, 470 nm, 560 nm, 580 nm and overlapping bands in the region to 800 nm. At the same time were recorded three major components of the luminescence decay time of 0.8 ns and 2.8 ns and 8.5 ns.

After X-irradiation the total emission intensity was increased on the order. In the luminescence spectra are dominated by two bands with maxima at 470 nm and 650 nm. However, a temporary structure is more complex. Observed components have decay time of 220, 35, 16, 4 and 0.8 ns. One of the components of the observed luminescence decay time is 16 ns, which is closest to the time of the luminescence decay time of F_2 - centers. Nevertheless, pronounced spectral emission band with maximum at 650 nm is different from the single crystal (680 nm).

Thus, we investigated a new material based on lithium fluoride, fluorescent properties of which differ significantly from the properties of single crystal.

This research was supported by the RFBR, project № 12-02-90054-Bel_a and the Program of Basic Research of SB RAS, project II.8.1.6.

**THERMOSTIMULATED LUMINESCENCE OF LiF: Mg, Ti,
IRRADIATED WITH FEMTOSECOND LASER PULSES IN MODE
OF THE FILAMENTATION**

**D.S. Glazunov¹, V.P. Dresvyanskiy¹, N.S. Bobina³, V.F. Ivashechkin³,
A. V. Kirpichnikov², A. V. Kuznetsov¹, A. I. Nepomnyashchih³,
E.V. Pestryakov², E.F. Martynovich¹**

¹*Irkutsk Branch of the Institute of Laser Physics SB RAS, Irkutsk, Russia*

²*Institute of Laser Physics SB RAS, Novosibirsk, Russia*

³*Institute of Geochemistry. AP. Vinogradov, SB RAS, Irkutsk, Russia*
e-mail: filial@ilph.irk.ru

The objects of our study were single crystals of dosimetric LiF: Mg (100 ppm), Ti (10 ppm) are widely used in the γ -dosimetry. The aim of this study was to investigate the mechanism of creation of light sum in crystals under the action of intense femtosecond radiation of Ti: sapphire laser in the near infrared region of ~ 800 nm, and a study the photoluminescence of irradiated samples. In addition, we compared the properties of the thermally stimulated luminescence after of the two methods of storing the light sum: laser radiation and X-rays or beta particles.

The experimental setup for irradiation of crystals of LiF: Mg, Ti by femtosecond laser pulses consisted of a Ti: sapphire laser that generates 30 fs pulses with energies of about 0,55 mJ and a repetition rate of 1-1000 Hz. Photoluminescent studies of irradiated samples was carried out under picosecond laser excitation with a scanning confocal fluorescent time reserved microscope MicroTime 200. PL spectra excited by laser radiation with a wavelength of 470 nm were recorded by spectrometer Ocean Optics QE65000. TSL studies were conducted at a special installation in the temperature range from 295 K to 673 K at a constant heating rate of 1 K s⁻¹. After measuring the thermoluminescence curves of the crystal irradiated by femtosecond radiation the TSL of the same sample was additionally investigated after irradiation with β -radiation of isotope source ⁹⁰Sr-⁹⁰Yt with dose 0,6 Gy/min. The exposure time of the sample with beta particles was 30 sec.

The results showed that the luminescence spectra of the crystals, irradiated with femtosecond laser radiation contains emission bands F₂-centers ($\lambda = 680$ nm) and F₃⁺ centers ($\lambda = 540$ nm).

The results of thermoluminescent studies show that after femtosecond excitation the main TSL peak is the usual dosimetric peak with a maximum of 485 K. In comparison with the X-ray and β -irradiation the higher temperature peaks recorded more efficiently. This is associated with a high excitation density of matter under laser excitation. Specifically, research has shown that due to the small size of filaments formed as a result of self-focusing ($1,3 \times 35$ μm), the density of color centers in filament traces of several orders of magnitude greater than the density after the beta- or X-ray irradiation.

This research was supported by the Program № 13 of the Presidium of RAS, project № 12 and by the Program of Basic Research of SB RAS, project II.8.1.6.

LUMINESCENT SPECTROSCOPY OF MOLYBDATE SOLID SOLUTIONS

A_{1-x}B_x(MoO₄), A=(Ca,Pb), B=(Pb,Sr,Ba,Cd)

I.A. Gofman, V.D. Zhuravlev¹, V.A. Pustovarov

*Ural Federal University, Ekaterinburg, Russia,
ilya.gofman87@gmail.com*

¹ *Institute of Solid State Chemistry of RAS (UB), Ekaterinburg, Russia*

Molybdates with common formula AMoO₄ (A=Ca,Sr,Pb,Ba,Cd) crystallizing in the scheelite type (space group I4₁/a), are considered prospective materials in luminescent applications, mainly as host lattices for rare-earth ions in production of LED phosphors. Solid solutions between the members of the series present a possibility of more detailed study of the crystal structure influence on the luminescent properties in molybdates.

Calcium molybdate CaMoO₄ has been found the most efficient luminescent material of all scheelite molybdates, therefore solid solution based on Ca²⁺ cation were studied. Lead molybdate consistently attracts attention of researchers because of its color center whose nature was discussed over years. Therefore, we decided to choose PbMoO₄ as the second base compound for solid solutions.

The following concentration dependences were studied for all the systems: 1) relative photo- and X-ray stimulated luminescence intensity; 2) main excitation peak energy; 3) emission peak energy. During the measurements we faced a number of experimental issues connected with the wide dynamic range of luminescence intensity and the need of variation of monochromator slit widths which causes shifts in broad emission and excitation spectra.

We found that in $\text{Ca}_{1-x}\text{A}_x\text{MoO}_4$ series relative luminescence intensity rapidly decreases with the increase in concentration x . The dependences are rather similar for both PL and XRL intensity. This even holds for $\text{A}=\text{Cd}$, despite the fact that ionic radius of Cd^{2+} is smaller than that of Ca^{2+} . This could be explained on the basis of two factors. Firstly, with the increase of the cation position size, the expansion of the molybdate tetrahedron in the excited state increases, which causes the stronger shift of the excited state parabola in the single configurational coordinate model. This, in turn, leads to earlier temperature quenching. However, if we consider further decreasing the cation size, like in case of Cd^{2+} the thermally activated concentration quenching mechanism might override and again decrease the luminescence intensity at room temperature. Therefore, there should exist an optimum, which seems to be located at CaMoO_4 . The quantitative analysis for this situation is being developed.

In the $\text{Pb}_{1-x}\text{A}_x\text{MoO}_4$ series the dependence of the excitation peak energy on concentration is of main interest. We found that its position is heavily dependent on Pb^{2+} concentration shifting up to 0.7 eV. The law is almost linear. This observations could help reject some of the versions of its origin, like the deviations in stoichiometry or the small amounts of accidental admixtures.

In some of the series, like $\text{Pb}_{1-x}\text{Ba}_x\text{MoO}_4$, where the relatively large difference between the emission peak energies existed ($E_{\text{em}}=2.36$ eV for $x=0.1$ versus $E_{\text{em}}=2.51$ eV for $x=0.9$) it appeared possible to plot the linear dependences of the emission energy on concentration. However, in most of the series emission energies were close enough for the dependences to be blurred by a variety of factors to make it impossible to construct an explicit dependence.

Thus the study of solid solutions series based on CaMoO_4 and PbMoO_4 made it possible to further refine the regularities in the excitation and emission energies and luminescence intensity of scheelite-structured molybdates.

**HIGH INTENSIVE CHORT PULSED IONS IMPLANTATION
EFFECT ON ELECTRICAL AND PHOTOELECTRICAL PROPERTIES
OF POLYCRYSTALLINE SILICON**

A.V. Kabyshev, F. V. Konusov, G. E. Remnev

*Institute of Physics of High Technology, Tomsk, Russia,
konusov@hvd.tpu.ru*

Synthesis of nanosized structures in silicon and silicon contained materials by ions irradiation presume investigation processes of grinding crystal structure, formation new phases defects formation and its effect on properties. High intensive short pulsed C^+ ions implantation with aim of synthesis carbon contained compounds in silicon carry out simultaneous annealing of induced defects. Induced heterogeneity in form of a-C:H, SiC, C-nanodiamonds, graphite condition characteristics change.

The purpose of this work is investigation reason of electrical and photoelectrical characteristics of polycrystalline silicon changes after high intensive short pulsed carbon implantation ions and subsequent vacuum annealing ($T_{an}=300-900$ K, $P<10^{-2}$ Pa). Implantation with C^+ ions (H^+ ions in beam ≤ 50 %) was fulfilled with using power impulse beam on the basis diode with outer magnetic isolation with dielectrics anode at parameters: $P\leq 10^{-2}$ Pa, $U_p=300$ kV, $t_{imp}=80$ ns, $j_p=30$ A/cm², $n_p=1-400$, $D_p\sim 1.5\cdot 10^{13}$ cm⁻². Surface and volume dark conduction σ , photoconduction $\Delta\sigma_{hv}=\sigma_{hv}-\sigma$ (σ_{hv} -conduction at illumination), photosensitivity $K=\Delta\sigma_{hv}/\sigma$ were measured at $T=300-500$ K, $U=0.1-300$ V, $h\nu=1.5-4.0$ eV.

Dose dependencies of photoelectrical characteristics are obey to common laws proper to silicon implanted with ions. The type of σ_{hv} changes from **n** to **p** and photosensitivity sharply drops. As shows parameters, hopping transport contribution to $\sigma(T)$ enlarges owing to growth of density of induced defects localized states distributed near Fermi level more than 10^3 degree. States density diminishes with its depth in band gap unlike unirradiated silicon. Levels parameters were determined by irradiation conditions.

Processes of defects annealing, ions precipitation, nanoparticles agglomeration and hard solution formation condition the characteristics change during annealing in stages $T_{an}=300-700$, $700-1000$ K. Dissociation of unstable acceptor defects complexes begining at 450 K is accompanies by type carriers restoration from **p** to **n**. Stable until 600 K complexes on basis donors like defects and implanting ions determine the Fermi level position in band gap and recharge defects. Nanocrystals provide the stabilized effect on characteristics connected with induced defects. Nanoparticles agglomeration ef-

fects on properties at $T_{an}=700-1000$ K. In summary, as a result of ion-thermal modification of polycrystalline silicon new strongly defective material was formed in near surface layer with considerably changed electrical and photoelectrical properties.

THE INTEGRATED GEOINFORMATION SYSTEM FOR REMOTE RADIATION MONITORING

**M. M. Kidibaev, A. V. Ishchenko¹, L. V. Victorov¹, K. O. Khokhlov¹,
T. S. Koroleva, A. S. Bektashov, V. Yu. Ivanov¹, B. V. Shulgin¹**

*Institute of Physical & Technical Problems and Materials Science of the
National Academy of Sciences of the Kyrgyz Republic, Bishkek, Kyrgyzstan,
koroleva@aknet.kg*

¹*Ural Federal University named after the first president of Russia
B.N.Yeltsin, Yekaterinburg, Russia,
a-v-i@mail.ru*

For monitoring of the biosphere reserve around the Lake Issyk-Kul, having an international status, the special integrated geoinformation system (IGS) has been created. Such automatic system for continuous monitoring is necessary for dynamic response to changing circumstances, accumulation of statistical data on the radiation background, as well as for early warning of the population about the excess of permissible rates. IGS represents an extensive hardware (Fig. 1) and software (user interface at Fig. 2) sensor system designed for collecting, storing and processing of information on radiation parameters of the environment. Using the system allows to perform a comprehensive landscape analysis and assessment of radionuclides distribution in surveyed areas, located far from the control center.

The system works both in a “standby” mode (recording of measurement results in the control center with a given time interval) and in a real time mode (second-by-second values of the average count rate, received from the sensors, are continuously observed on the monitor in the control center). IGS consist of some remote smart sensor units on the basis of CsI:Tl scintillation detector with PIN photodiode registration and integrated control center on basis of software “Karakol”.

Works were performed within the ISTC projects #KR-994 and #KR-1587 by the international team of researchers from the National Academy of

Sciences of the Kyrgyz Republic and the Ural Federal University (Yekaterinburg, Russia), with the assistance of respected collaborators from the University of Lyon 1, France (Prof. Ch. Pedrini), Fraunhofer Institute for Non-Destructive Testing (IZFP), Germany (Prof. M. Kroening) and WISMUT Corporation, Germany (Dr. P. Schmidt

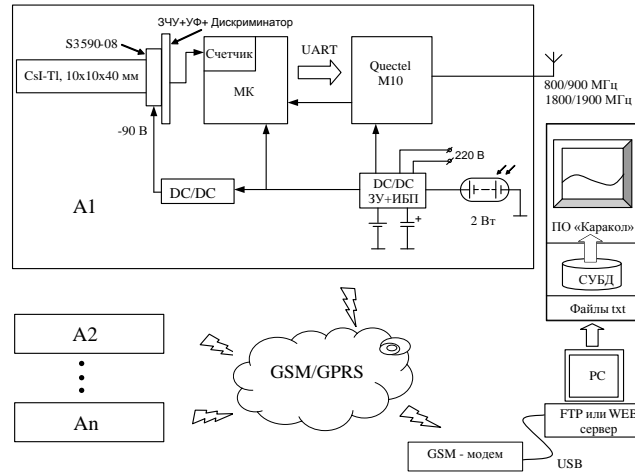

Fig. 1. Scheme of IGS

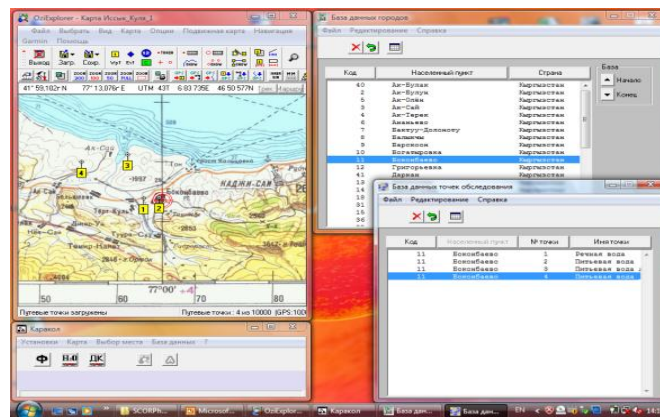

Fig. 2. User Interface of IGS

RESEARCHING X-RAY INFLUENCE ON THE HYDROGEN REDISTRIBUTION IN TITANIUM WITH THE HELP OF PROFILER 2 GLOW DISCHARGE OPTICAL EMISSION SPECTROMETER

V. N. Kudiyarov, A. M. Lider, N. S. Pushilina

Tomsk Polytechnic University, Tomsk, Russia, victor31479@mail.ru

Titanium and its alloys are materials of great technological interest due to the combination of the two mechanical properties of resistance to corrosion and hardness. Hydrogen in metals and alloys is known to cause embrittlement. For titanium and titanium alloys the presence of hydrogen and titanium hydride enhances the fracture by localized plastic deformation and brittle fracture respectively.

In a number of studies [1-2] it investigated that by acting at room temperature for metal-hydrogen system by ionizing radiation migration and hydrogen yield can be stimulated. So it becomes possible the low-temperature hydrogen removal from metals.

The aim of our research is to study the influence of X-rays on the hydrogen redistribution in titanium. The researching was carried out with the help of Profiler 2 glow discharge optical emission spectrometer [3].

Analyzing hydrogen concentration profiles in the samples before and after irradiation shows that irradiation stimulates hydrogen migration from bulk of the samples to the near surface layer of the samples.

References

1. Turin Yu.I., Chernov I.P. Radiation-stimulated hydrogen desorption from solid. – Tomsk: Tomsk Polytechnic University, 2008.-252 p.
2. Chernov I.P., Cherdancev Yu.P., Turin Yu.I. Methods of researching metal-hydrogen system. - M.: Tomsk: STT, 2004. -270 p.
3. Thomas Nelis, Jozsef Pallosi. Glow Discharge as a Tool for Surface and Interface Analysis. Applied Spectroscopy Reviews, 41: 227–258, 2006.

RESEARCH OF ABLATION OF TARGETS FROM HEAT-RESISTANT OXIDES UNDER ACTION OF CO₂ AND FIBER LASERS

V.V. Lisenkov, V.V. Osipov, V.V. Platonov

Institute of Electrophysics UD RAS, Ekaterinburg, Russia

The ablation of targets from heat-resistant oxides by CO₂ and ytterbium fiber lasers has been investigated theoretically and experimentally in present paper.

CO₂ laser generated pulses with following parameters: energy – 1 J, duration – 250 μs, peak power – 7 kW. The fiber laser generated rectangular pulses with 300-1000 μs duration and 300-700 W power.

The theoretical investigations were carried out with a help of 3D numerical model, which included the equations of heat conductivity and movement of melt. With a help of our model we have calculated the dynamics of evaporation of target material together with the displacement of the melt under action of overpressure of vapor. These processes result in formation of a crater.

Quite good concurrence between calculated and experimental parameters of craters has been received.

Results of researches have revealed essential difference between CO₂ and fiber lasers in processes of heating and evaporation of targets. In case of CO₂ laser the evaporation of a material take place basically from the melt surface. In case of the fiber laser the basic part of a material takes off as a vapor-drop mix. Such mode results in more effective removal of target material that is good for laser drilling and cutting. However for synthesis of nanopowder such mode is not good. In our opinion, for synthesis of nanopowder it is better to use CO₂ the laser.

**INFLUENCE OF THERMOBEAM PROCESSING ON TL AND
OSL PROPERTIES OF THE SOLID-STATE DETECTOR OF
IONISING RADIATION ON THE BASIS OF ANION-
DEFECTIVE CORUNDUM**

**Litovchenko E.N., Soloviev S.V., Milman I.I., Moiseikin E.V.,
Surdo A.I.***

Ural Federal University, Ekaterinburg, Russia, e-mail:

Igor.Milman@dpt.ustu.ru

**Institute of industrial ecology of Ural branch of Russian Academy,
Ekaterinburg, Russia, e-mail: Surdo@ecko.uran.ru*

Solid-state detectors based of anion-defective corundum (TLD-500 or $\text{Al}_2\text{O}_3:\text{C}$) are widely used in personal, medical and space dosimetry [1]. Crystal detectors $\text{Al}_2\text{O}_3:\text{C}$ possess high sensitivity and a wide range of registered doses of radiation, thermal and radiating firmness, are chemically inert.

In Ural Federal University the method of thermobeam preparation of crystals $\text{Al}_2\text{O}_3:\text{C}$ which allows increase a range of registered doses is developed. The method consists at irradiation of crystals of anion-defective corundum light with length of wave 200-220 nanometers at temperature 250-350°C. At such processing there is filling deep traps and the probability of capture carriers them decreases at the subsequent irradiation. As a result, sensitivity of detectors to registered radiations [2] increases at one order, and the change of sensitivity in the basic peak it is possible to estimate the dose of the radiation which have been saved up at the raised temperature [3]. Registration the absorbed dose of crystals $\text{Al}_2\text{O}_3:\text{C}$ can is made both methodes: thermoluminescent (TL) and optically stimulated luminescences (OSL).

In this work, TL and OSL - properties of detectors TLD-500K subjected to thermobeam processing in a temperature range from 50 to 800°C are resulted. It is shown that the increase in intensity TL and OSL a signal in the basic peak is connected as with intensive filling of the traps competing to basic - dosimetric, at irradiation temperature 300-400°C, and with change of concentration of the basic centres of a luminescence. As a result, the registration of TL and OSL signals, growth of sensitivity of samples to x-ray radiation more than on two order is observed.

[1] Optically stimulated luminescence: fundamentals and applications / Eduardo G. Yukihara and Stephen W.S. McKeever., 2011

[2] Patent RU № 2229145. A method of processing substance of the solid-state detector of ionizing radiation detectors based on aluminum oxide / Kortov V.S., Milman I.I., Nikiforov S.V.

[3] Patent RU № 2346296 Method for measuring the dose in solid-state detectors of ionizing radiation on the basis of aluminum oxide, accumulated at higher ambient temperatures / Milman I.I., Moiseikin E.V., Nikiforov S.V., Revkov I.G., Litovchenko E.N., Soloviev S.V.

FORMATION AND THE TRANSFORMATION OF CONTAMINANT-DEFECTIVE COMPOSITIONS IN DOPED SILICON AT THERMAL RADIATION INFLUENCE

**Sh. Makhkamov, M. Karimov, N.A.Tursunov, A.R. Sattiev,
M.N. Erdonov, Sh.A. Makhmudov, Kh.M. Kholmedov**

*Institute of Nuclear Physics AS RUz, Tashkent, Uzbekistan,
natur@inp.uz*

In the work the process of formation and reconstruction of contaminant-defective compositions are studied by electrical and structural methods in silicon doped by impurity of the copper and palladium with the participation of dislocations under the thermal radiation influence.

For it were used a silicon single-crystal samples of p-type conductivity, grown by Czochralski's method with specific resistance 10 Ohm·cm and dislocation density $\sim 10^4 \text{ cm}^{-2}$. The doping of the silicon plates was produced by thermal-diffusion method in the range of temperatures 1000-1280⁰C for 5-10 hours. Irradiation by neutrons was carried out up to the fluencies $3 \cdot 10^{19} \text{ cm}^{-2}$.

The measurements showed small changes of electrophysical and recombination parameters of the silicon samples, alloyed by copper. The decrease of the life time of the minority charge carriers is observed in control samples. A substantial change of electrophysical and recombination parameters in silicon by admixture of palladium in contrast to copper is observed.

For control samples a structural studies showed the tendency of an increase in density and sizes of the dislocation pits of etching with an increase of cooling rate. By dislocation glide in the samples doped by copper occurs their confluence with the formation dislocation many leafed rosettes and tubes. Motion and confluence to the formed dislocation nucleus for Si<B, Pd> is observed.

Study of Si<B,Cu> after neutron irradiation by fluencies $3 \cdot 10^{19} \text{ cm}^{-2}$ showed an increase of the dislocation density for control samples relatively no irradiated. Copper impurity presence in the doped samples leads to insignificant decrease of dislocation density relatively control samples. Pairing dislocations and formation of three petalous dislocation rosettes occurs and located from each other to 120° .

Study of the silicon strength parameters, doped by Cu and Pd impurities established the nature of contaminant composition influence to their microhardness. Was shown that Cu and Pd impurities leads to disordering (due covalent radius difference) of single-crystal silicon and discovered, that process of strengthening is suppressed by the precipitation of oxygen, due to the diffusing atoms Cu and Pd interaction with oxygen and seizure by their growing precipitates. Contribution to strengthening of doped silicon leads to dislocations, generated by the elastic strains fields, created by admixtures.

The mechanism of formation and transformation of contaminant- defective complexes with the participation of dislocations and structural defects is discussed, and their contribution to an increase in photosensitivity and radiation stability of the doped semiconductor materials is established.

Work is executed within the framework of F2-FA-F121 grant of Committees on Coordination of Development Sciences and Technology.

DEFECTS CREATION IN WIDE BAND-GAP CRYSTALS BY AN INTENSE NEAR INFRARED LASER RADIATION

E.F. Martynovich

Irkutsk Branch of the Institute of Laser Physics SB RAS, Irkutsk, Russia
e-mail: filial@ilph.irk.ru

1. At low aperture focusing of a femtosecond Ti: sapphire laser radiation the defects are produced due to the self-focusing and multiple filamentation of light with the sharp increase in its intensity.

2. Highly sensitive fluorescence technique allowed for the first time to register the spatial distribution of traces color centers created by filaments of a single laser pulse (0.5 mJ). We measured the thickness (1.3-1.5 mm) and the effective length (~ 30 microns) of filaments in the simplest terms of the action of a single pulse. Short length of the filaments shows that the primary mechanism of filamentation is a mechanism of moving the focus.

3. Elongation (germination) of traces was observed first time with an increase in the number of pulses of radiation. The reason it is a channeling effect of light by waveguides formed by the first pulses. Through this traces not only lengthened, but increased in diameters, and their cross-section of the fluorescence emission took the form of rings because of concentration quenching of luminescence, rising to the axis of the rings.

4. At high external aperture focusing the optimum regime of defect creation is achieved by the reduction of pulse energy in the minimum unit volume with a cross section smaller than the diffraction limit due to the nonlinear narrowing.

5. It was shown that the femtosecond laser as a tool for the creation of radiation defects in wide band-gap crystals, many times more effective than X-ray machines, powerful gamma-irradiation isotope installations and linear electron accelerators.

6. For the first time within the crystalline media volume information was recorded in the form of multi-level fluorescent images or digital codes.

This research was supported by the Program № 13 of the Presidium of RAS, project № 12 and by the Program of Basic Research of SB RAS, project II.8.1.6.

SYNTHESIS, CHARACTERIZATION AND LUMINESCENT PROPERTIES OF HIGH DOSE IRRADIATED NANOSTRUCTURED ALUMINA CERAMICS

**K.A. Petrovykh, V.S. Kortov, S.V. Nikiforov, S.V. Zvonarev,
Yu.G. Ustyantsev**

*Ural Federal University named after first President of Russia B.N.
Eltsyn, Ekaterinburg, Russia, kspetrovyh@mail.ru*

The aim of the present work is synthesis and characterization of nanostructured α -Al₂O₃ ceramics with further studying of its luminescence after high dose irradiation.

The preparation process of nanostructured alumina ceramics involves three stages: synthesis of high-purity α -alumina powder, powder compacting, and sintering in vacuum.

Synthesis of the α -Al₂O₃ used in our studies was performed by CJSC “VNIOS NK” using alcoholate technology. It is based on alcoholysis of

aluminum with isopropyl alcohol followed by purification of the aluminum isopropoxide, and then its hydrolysis to $\text{Al}(\text{OH})_3$ and the thermal dissociation of the latter to the final product.

The analysis of particle size distributions for initial high-purity alumina was performed by means of the dynamic light scattering technology. During the experiment based on dry sample material high concentrated suspension was made. This suspension was treated 10 minutes with an external ultrasonic probe. After time pause of three minutes a partial sample from the surface of the liquid was taken, so that coarser particles, which are already settled to the bottom of the container, would not be caught. This partial sample was filtered at 1200 nm before the suspension was given into the cuvette for analysis. According to obtaining results the minimum and medium particle sizes of the $\alpha\text{-Al}_2\text{O}_3$ powder are 12 nm and 100 nm, respectively. Received size values are validated by results of scanning electron microscopy (SEM) that showed 100-110 nm particles.

The powder compacting to realize 1 mm thick tablets was made by cold moulding technique under pressure of 8-9 kgf/cm² with an ethanol as plasticizer.

As to the next step, the tablets were sintered in a high temperature vacuum furnace at the temperatures of about 1100-1500 °C for 1 hour. One should mention after sintering the particle size was varied in a 200-400 nm range in accordance with SEM data.

The thermoluminescence (TL) of the prepared nanoceramics was measured after irradiation of ⁹⁰Sr source in a dose range from 1 to 500 Gy. Under heating of irradiated ceramics in a range of 350-500 K the TL was observed. The TL output is proportional to the absorbed β -radiation dose in a dose range from 1 to 200 Gy. At the same time dose response of the $\alpha\text{-Al}_2\text{O}_3$ single-crystal is linear in the region limited by 1 Gy. Thus the work results prove prospectivity of the $\alpha\text{-Al}_2\text{O}_3$ nanostructured ceramics as materials for high dose detectors of the ionizing radiation.

RADIOLUMINESCENCE PROPERTIES OF Cs-METAVANADATES

**R. F. Samigullina, B. V. Slobodin, A. V. Ishchenko¹, B. V. Shulgin¹,
L. V. Victorov¹, V. V. Vakhter¹, E. A. Zhevak¹**

*Institute of solid state chemistry of Ural branch of Russian Academy of
Sciences, Yekaterinburg, Russia, rina@ihim.uran.ru*

¹*Ural Federal University named after the first President of Russia
B.N.Yeltsin, Yekaterinburg, Russia, a-v-i@mail.ru*

The CsVO₃ (sp. gr. P4/nbm) and Cs₂Zn(VO₃)₄ (sp. gr. P4/mnc) metavanadates have been synthesized by the Pechini process in polycrystalline form. The CsVO₃ crystal grains (Fig. 1) have been made due to melting and slow cooling. The photo- and X-ray luminescence, scintillation and luminescent decay properties have been measured. The X-ray spectra of CsVO₃ in comparison with spectra of ZnO etalon (measured in the same conditions) and spectra of Cs₂Zn(VO₃)₄ are presented at Fig. 2 and Fig.3, respectively. The calculated absolute light yield of CsVO₃ is 46000 photon/MeV. It's more than the absolute light yield of NaI:Tl (38000 photon/MeV [1]). The decay time measuring (Fig. 4) under photon irradiation and pulse cathode beam were performed. It equal 11,3 us.

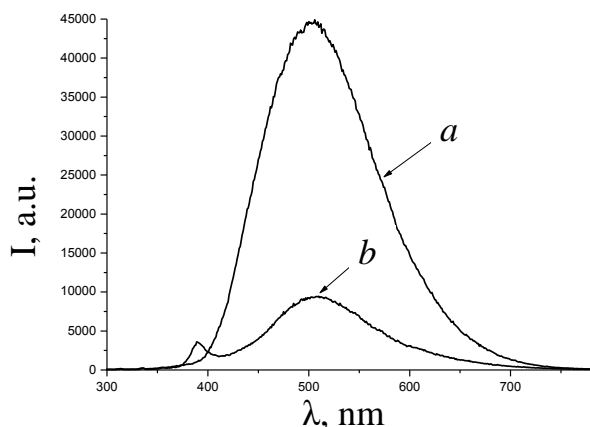
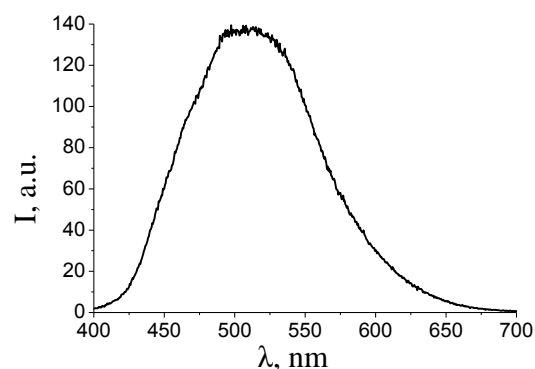
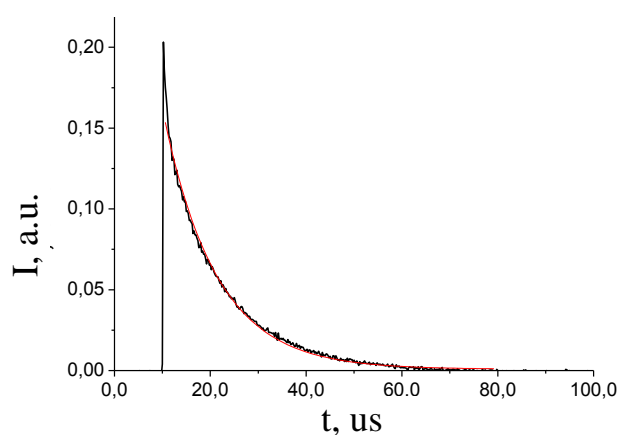

Fig. 1. CsVO₃ crystalline grain

Fig. 2. X-ray spectra of CsVO₃ (a) andFig. 3. X-ray spectra of Cs₂Zn(VO₃)₄Fig. 4. CsVO₃ decay curve

The presented compounds are perceptively materials for luminescence indication monitoring systems including systems combined with photodiodes registration.

Work was supported by the Russian Foundation for Basic Research (grant no. 110300097a) and supported by state contract in the framework of federal special-purpose program “Scientific and research and educational cadres of innovation Russia” (2009-2013).

1. NaI(Tl) and Polyscin®NaI(Tl) Sodium Iodide. Scintillation Material. <http://www.detectors.saint-gobain.com>.

**ATOMIC STRUCTURE OF SELF-ASSEMBLED InAs/AlAs
QUANTUM DOTS: EFFECT OF ELECTRON IRRADIATION
AND ANNEALING**

T.S. Shamirzaev¹, A.K.Bakarov¹, V.Yu. Yakovlev²

¹ *A.V. Rzhanov Institute of Semiconductor Physics SB RAS, Novosibirsk, Russia, tim@isp.nsc.ru*

² *Tomsk Polytechnic University, Tomsk, Russia,*

Effect of post-growth annealing and electron irradiation on intrinsic point defect concentration and intermixing in structures with InAs/AlAs quantum dots has been investigated. The structures were grown by molecular beam epitaxy in a Riber-32P system at temperature of 510°C and consist of a single layer of InAs QDs sandwiched between two 50 nm layers of AlAs. A 20-nm-thick GaAs cap layer protects AlAs against oxidation. In order to dope the structures by electrons (holes) a delta layer of Si (Be) atoms with density of $5 \times 10^{11} \text{ cm}^{-2}$ putted 2 nm under the QDs layer. Both n- and p-doped structure are treated by a pulse electron irradiation (100 pulses with pulse density of 0.3 J/cm^2 and electron energy of 250 keV). As-grown and irradiated structures were annealed in a hydrogen flow during 15-30 minutes at temperatures in the range of 430 – 750°C. 15 minutes annealing at 550°C does not affect photoluminescence (PL) intensity and spectra shape for both n- and p-doped structures. Increase of the annealing temperature up to 700°C (during 15 minutes) results in blue shift of PL band for the n-doped structure, while similar shift for the p-doped structure observed just for annealing temperature of 750°C. Pulse electron irradiation does also not affect PL spectra shape for both the structures and intensity of the p-doped structure. However, intensity of the n-doped structure increases in 1.4 times after such irradiation. Additional 30 minutes annealing of the irradiated structures at 430°C does not any affect the p-doped structure. The same annealing results in additional 1.6 times increase intensity and blue shift of PL band for the n-doped structure that evidences recombination of intrinsic point defects – nonradiative centers and some intermixing of InAs and AlAs. We explain our results with the following model: intermixing of InAs and AlAs are gone via intrinsic point defect (vacancy and interstitial atom) generation. The formation enthalpies of intrinsic point defects are function of Fermi level position. In n-doped structures the Fermi level has energy in 1.5 eV higher than that in p-doped one, that facilitates the defects generation. Irradiation increases of the Fermi level energy that causes of the defects generation. Migration of these generated de-

fects during annealing results in InAs and AlAs intermixing and recombination of intrinsic point defects. This work was supported by the RFBR (grant no.10-02-00240).

PORTABLE GAMMA-RADIATION MONITOR ON THE BASIS OF PLASTIC SCINTILLATOR

**A. S. Shein, A. Yu. Derstuganov, G. A. Kuntsevich, A. L. Krymov,
L. V. Victorov, V. L. Petrov, B. V. Shulgin**

¹*Ural Federal University named after the first President of Russia
B.N.Yeltsin, Yekaterinburg, Russia, b.v.shulgin@ustu.ru*

The portable gamma-radiation monitor on the basis of plastic scintillator was developed. It is designed for registration levels of dose of gamma radiation with reference to geographic coordinates. Portable monitor has many advantages in comparison with other devices, some of them:

- high sensitivity;
- various working modes;
- unique search and detection algorithms;
- et al.

Sample of the portable gamma-radiation monitor shown in Fig. 1.

- 1 – plastic scintillation detector;
- 2 – smart unit of electronics;
- 3 – easel backpack;
- 4 – antenna (radio channel);
- 5 – antenna (GPS).
- 6 – accumulator;
- 7 – straps of the pack;
- 8 – LCD;

These advantages allow search for gamma-radiation sources in remote places far more effective in comparison with known analogues. Portable monitor can be applied as an extension of mobile radiation monitoring systems or as stand-alone system. Furthermore, this device can be used for evaluating the radiation situation with the construction of an electronic radiation map.

Sample of the portable gamma-radiation monitor is tested and fully confirmed the declared characteristics.

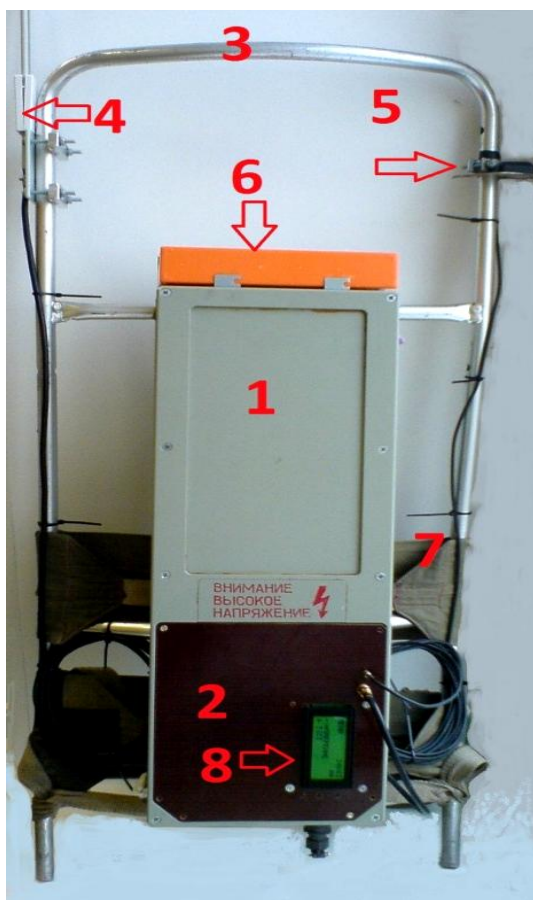

Fig. 1. Sample of the portable gamma-radiation monitor.

DETECTOR MATERIALS AND DEVICES FOR RADIATION MONITORING

**B. V. Shulgin, A. V. Kruzhalov, V. L. Petrov, L. V. Victorov,
A. S. Shein, V. S. Andreev, A. L. Krymov, V. Yu. Ivanov,
A. N. Cherepanov, A. V. Ishchenko, A. Yu. Derstuganov,
V. A. Terekhin¹, Yu. I. Chernukhin¹, O. N. Shutov²,
M. N. Blagoveshchenskii², V. G. Grebnyak², T. S. Koroleva³,
M. M. Kidibaev³**

*Ural Federal University named after the first President of Russia
B.N.Yeltsin, Yekaterinburg, Russia, a-v-i@mail.ru*

¹ *Snezhinsk Physics and Technology Institute, Snezhinsk, Russia,
terekhinva@gmail.com*

² *Gamma Ltd, Yekaterinburg, Russia, shutov@ooogamma.ru*

³ *Institute of Physical & Technical Problems and Materials Science of
the National Academy of Sciences of the Kyrgyz Republic, Bishkek, Kyrgyz-
stan, koroleva@aknet.kg*

The radioluminescence properties of some oxide and fluoride materials in bulk, fiber, polycrystalline and nanostructured forms have been investigated. As results of these fundamental and applied research some new detector materials and devices for radiation monitoring have been proposed on the level of author's patent for inventions and useful models. Some of these creations are presented in this report.

Patent for inventions:

Pat. RU № 2435173, method of U-235 and Pu-239 fission material control;

Pat. RU №№ 2449316 and 2445646, sensor materials for thermostimulated detectors;

Pat. RU № 2411280, two-layer fiber scintillation materials;

Pat. RU № 2441256, fiber electron and beta-radiation detector;

Pat. RU on application № 2012114988, heterogeneous scintillation detector (HSD) of electron and beta radiation;

Pat. RU on application № 2010133473, HSD of neutron (in collaboration with professor C. Pedrini, Lyon Univ., France);

Pat. RU on application № 2011111915, method of search and detection of radiation sources;

Some of new technical decisions have been proposed on the level of useful models:

Pat. RU № 100296, basis spectroradiometer unit for mobile laboratory of radiation control;

Pat. RU № 98823, mobile systems (dosimetric laboratory) of radiation control with scanning and non-scanning gamma-detectors;

Pat. RU №№ 100294 and 113024, neutron detector design on the basis of ^3He -counters;

Pat. RU № 112449, scintillation plate detector for underwater monitoring;

Pat. RU on application № 2012107934, scintillation fiber detector for underwater monitoring;

Pat. RU № 105474, scintillation multitarget compact detector;

Pat. RU № 98826, spherical scintillation detector with PIN-PD registration;

Pat. RU № 100271, heterogeneous gamma-detector for radiation control.

By using some of these technical ideas the integrated geoinformation system for remote radiation monitoring residential Issyk-Kul lake area in the frame of project of International Science Technical Center (projects KR-994 and KR-1587) have been created at last years.

CALCULATION OF KINETIC PARAMETRES HIGH-TEMPERATURE TL PEAKS OF ANION-DEFECTIVE CORUNDUM

Soloviev S.V., Milman I.I., Surdo A.I.*

Ural Federal University, Ekaterinburg, Russia, e-mail:

Igor.Milman@dpt.ustu.ru

** Institute of industrial ecology of Ural branch of Russian Academy,*

Ekaterinburg, Russia, e-mail: Surdo@ecko.uran.ru

Deep traps in dosimetric anion-defective crystals Al_2O_3 make essential impact to parametres of the basic thermoluminescent (TL) peak nearby 450K. Depending to filling with their carriers of the charge, a kind and irradiation dose, changes in temperature position, sensitivity and the form of the basic peak, occurrence the nonlinear communication between TL response and irradiation dose are observed. The greatest influence to dosimetric properties is rendered by a trap responsible for TL peak nearby 700K.

It is known [1], that the basic TL peak in anion-defective crystals Al_2O_3 , with growth of speed of heating, tests temperature quenching which explain non-irradiation transitions of carriers of the charge which probability increases with temperature growth. The majority methods of definition kinetic parameters of traps do not consider effect of temperature quenching. Accordingly, the received values parameters do not allow to reach satisfactory coincidence at comparison experimental and settlement TL for several speeds of heating. Recently, for calculation the valid values kinetic parameters of traps the reconstruction experimental TL curves to a kind in absence of temperature quenching [2] is used.

In work results the research TL in monocrystals of anion-defective corundum $\alpha\text{-Al}_2\text{O}_3$ nearby 700K are presented at change the speed of heating. Research is spent for two conditions: with empty and filling deep traps. For definition a key parameters of the traps the algorithm reconstruction TL curves is used. Reliability to the received results is checked up an example of calculation parameters of a trap responsible for the basic TL peak.

[1] G. I. Dallas, D. Afouxenidis, E. C. Stefanaki, N. F. Tsagas, G. S. Polymeris, N. C. Tsirliganis, and G. Kitis. Reconstruction of the thermally quenched glow-curve of $\text{Al}_2\text{O}_3\text{:C}$ *phys. stat. sol. (a)* 205, No. 7, 1672–1679 (2008) / DOI 10.1002/pssa.200824016.

[2] M.T. Jose, S.R. Anishiaa, O. Annalakshmi and V. Ramasamy Determination of thermoluminescence kinetic parameters of thulium doped lithium calcium borate 10.1016/j.radmeas.2011.08.001

SIMULATION OF ELECTRON FIELD EMISSION FROM THE SURFACE OF IONIC CRYSTALS UNDER IRRADIATION BY A PULSED ELECTRON BEAM.

S. A. Stepanov, V. F. Shtan'ko, E. P. Chinkov

*National Research Tomsk Polytechnic University, Tomsk , Russia,
stepanovsa@tpu.ru*

Investigations of energy dissipation in the sample when subjected to a pulsed electron beam in the nanosecond time scale is very difficult and time consuming. Note that the experimental measurement certain very important parameters is practically impossible. In this case, the only method that allows a better understanding of the diversity and relationships of the experimental facts is the mathematical modeling.

When exposed to the semiconductor or dielectric pulsed electron beam high-density simultaneously there charging of the solid and intensive generation of in it of nonequilibrium electrons and holes, which creates favorable conditions for the emergence field electron and thermionic emission from a solid surface.

On the basis of the phenomenological model of field emission, we calculated current density of field emission from the surface irradiated by a pulsed electron beam for a series of ionic crystals when changing parameters of the beam.

Results of calculations show that after a certain time relative to the start of irradiation there is a sharp increase in current density of field emission. The factor that determines the beginning of the field emission, is the value of energy of the electron affinity. When the electric field near the irradiated surface and the concentration of nonequilibrium electrons reach some critical value, the current density field emission starts to become more current density pulsed electron beam. As a result, violated the criterion of stability of the system, which leads to the appearance of bifurcations in the beginning, and then the stochastic high-frequency oscillations in the system. Most clearly this instability as a bifurcation or stochastic oscillations are seen in crystals of KF, LiF and KCl with a low electron affinity. Instability processes of field emission current are implemented for other ionic crystals (NaCl, KBr, KI), but at higher excitation densities.

THE ENERGY BALANCE OF THE “CHARGED PARTICLE BEAM-TARGET” SYSTEM AT EROSION OF A METAL SURFACE

O.M. Stepanova, V.P. Krivobokov

*National Research Tomsk Polytechnic University, Tomsk, Russia,
omsa@tpu.ru*

The solid irradiation with a pulsed charged particle beam of the wide range power density ($10^5 \dots 10^9$ W/cm²) is characterized by a complex structure of energy dissipation. The main energy distribution channels are heating up, melting, and evaporation [1]. The energy balance control for the “charged particle beam-target” system makes it possible to increase the energy efficiency for technologies.

The dissipation structure of energy released in a target under irradiation with pulsed ion beam is considered. To describe the energy distribution several parameters have been introduced. That are the energy absorption coefficient – to take into account the energy expenditure on collision sputtering, the screening coefficient – to characterize the energy absorption in vapor, and the erosion energy efficiency. The calculation of evaporation kinetics has been carried out with the heat erosion model [2].

The function of energy release has two independent components: current density time variation in an impulse $j(t)$, and the space distribution of linear energy losses on a target depth $Q(x)$. Its formula is:

$$W(x, t) = \frac{\beta}{e} j(t) Q(x).$$

In it, the coefficient β includes the energy expenditure on sputtering. It is calculated according to the expression:

$$\beta = \frac{(E_b - S \cdot U_0 \cdot \frac{1}{e} \int_0^\tau j(t) dt)}{E_b}.$$

where E_b – energy flux density of a beam, S – sputtering coefficient, calculated according to the statistical model [3, 4], U_0 – surface binding energy of target atoms, τ – impulse duration, e – the electron’s charge.

Investigation of energy balance structure has been done by examples of copper and silver irradiation with 1 keV...1 MeV argon ions. The potentials of directional change of substance state via control of beam energy distribution

between possible dissipation channels are revealed. The beam parameters correlation with the characteristics of erosive effect is discovered.

The work has been supported by grant of the President of the Russian Federation for young scientists MK-3502.2012.2.

[1] O.M. Stepanova, V.P. Krivobokov, *Izvestiya Vysshyyh Uchebnyh Zavedeniy. Fizika*, 54 (1/3) (2011) 230-237.

[2] O.M. Stepanova and V.P. Krivobokov, *Bulletin of the Russian Academy of Sciences: Physics*, 74 (2) (2010) 122-125.

[3] S.A. Schwarz and C.R. Helms, *Journal of Applied Physics*, 50 (8) (1979) 5492.

[4] Kh. I. Grais, A.A. Shaltout, S.S. Ali, R.M. Boutros, K.M. El-behery, Z.A. El-Sayed, *Physica B*, 405 (2010) 1775-1781.

LOCAL NONEQUILIBRIUM MASS TRANSFER IN BINARY SYSTEM UNDER CONCENTRATED ENERGY FLUX IRRADIATION

G. A. Vershinin, V.A. Volkov, G.L. Buchbinder

*Dostoevsky Omsk State University, Omsk, Russia,
vershinin@phys.omsu.omskreg.ru*

A space-time nonlocal mass transfer of the impurity particles from the surface to the bulk of a metal under the influence of the high power particles beams or the laser irradiation is considered. In the frame of this model the influence of initial flux rate on mass transfer is investigated. The impurity concentration profiles have been obtained on the basis of the numerical solution of the integro-differential equation for the diffusion flux. It has been shown that for the time $t \leq t_d$, where t_d is the time of relaxation of the diffusion flux to its local equilibrium value, the wave mechanism of the mass transfer dominates over diffusion one. The assumptions concerning some experimental results are given.

INVESTIGATION OF THE NANOSTRUCTURES FORMATION IN THE IRRADIATED BY γ – QUANTA SINGLE-CRYSTAL SILICON WITH ULTRASONIC METHOD.

I.Kh. Abdukadirova, T. Khaydarov, Yu. Karimov

*Institute of Nuclear Physics of Academy Sciences of Uzbekistan, Uzbekistan
e-mail: izida@inp.uz*

It's determined that a phasic dynamics of deformation strengthening of single-crystal silicon irradiated by γ – quanta (with energy $\sim 1,27$ MeV) in the wide region of doses (from 10^2 up to 10^9 rad) by the internal friction measurement with widely known ultrasonic resonance method. We have detected appearance maximum on the dependence of internal friction (Q^{-1}) from dose at 10^5 rad in the samples p- Si with density of dislocations more then 10^3 cm^{-2} . Besides it the instability of nanodimensional dislocation structures has been established in the doses interval from 10^6 up to 10^9 rad, due to the formation and accumulation in the crystal lattice of the point like and continuous radiation defects (evolution of the dislocation densities in metals with rise of deformation were considered in [1-4]). On the temporal dependence $Q^{-1}(t)$ throughout 1,5 - 2 hours after irradiation the maximum has been established which position depends from ionizing dose. We suppose that such behavior of the $Q^{-1}(t)$ function is connected with manifestation of migration activity which coherent with annihilation of the dislocation loops in the first 1,5-2 hours when it's growing in 2,5 times starting from the initial up to the maximum value. At the increasing of the observation time after stopping of the sample irradiation it is observed a monotonic decrease of $Q^{-1}(t)$ dependence, which is obviously connected with decreasing of the radiation defects densities in the result of their annihilation.

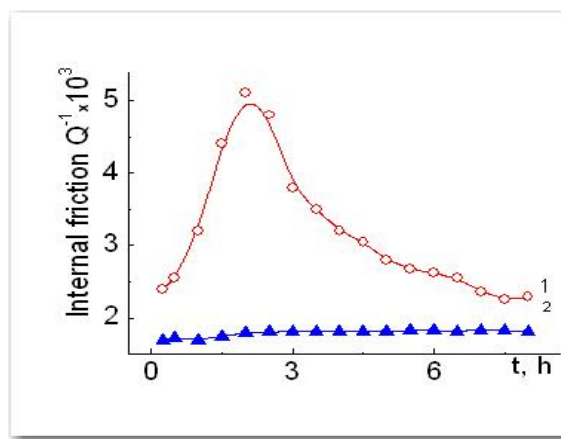

Fig.1 Time dependence of the single-crystal silicon internal friction after stop of the irradiation action.

References

1. Г. А.Малыгин. ФТТ **51**, 1709 (2009)
2. А. Малыгин. ФТТ **48**, 651(2006)
3. A.Godfrey, D.A. Hughes. Scripta Matter. **51**,8,831 (2004)
4. A.Godfrey, D.A. Hughes. Scripta Matter. **48**,8,1987 (2000)

**RADIATION-INDUCED OF A DIELECTRIC ABSORPTION
IN THE OXIDE ALUMINUM**

I.Kh. Abdukadirova

*Institute of Nuclear Physics Academy of Sciences Uzbekistan
100214 Tashkent. Uzbekistan. Ulugbek. e-mail: sandalov@inp.uz*

According to experimental data of the electric parameter - dielectric loss tangent ($\text{tg}\delta$) at 300 Hz for the samples of oxide aluminum after irradiated to a dose 10 kGy at various temperature (25-450 °C) was seen, that $\text{tg}\delta(T)$ function in gamma-irradiated crystals changed nonlinearly. Irradiation of the sample complicated the behavior in the low-temperature region, whereby an intermediate stage above 150 °C appears with a peak at 250 °C.

A comparative analysis of the temperature dependence of losses in the two samples showed that the $\text{tg}\delta(T)$ function of the irradiated crystal lies above that of the initial crystal, while temperatures the pattern is reversed. Thus, the temperature dependence of the $\text{tg}\delta$ crystal varies in a complicated manner. Apparently, the mechanism of dielectric losses in the two regions is also different.

It is believed that the observed radiation-induced effect, whereby the dielectric absorption appears in the region of elevated temperatures, is related most probably to the dielectric polarization, in particular, to the relaxation polarization. In order to elucidate these factors, consider the following.

The relaxation time τ of the thermal ion polarization depends on the nature of substance and on the temperature. Assume a single crystal insulator in which all atoms involved in the thermal ion polarization possess the same activation energy and, accordingly, the same relaxation time τ_0 . Then, the exponential temperature dependence of τ for the ion polarization can be written as :

$$\tau = \tau_0 \exp (E_{\pi} / \kappa T) \quad , \quad (1)$$

where κ is the Boltzmann constant, T is temperature, E_{π} is the polarization activation energy.

Using formula (1), we obtain the following expression for the activation energy:

$$E_{\pi} = \ln(\tau / \tau_0) k T \quad (2)$$

Substituting the known values of constants and the parameters of dielectric absorption determined for the samples studied and taking into account the maximum of losses at $\omega \tau_0 = 1$, we obtain the polarization activation energy $E_{\pi} = 0,76$ eV. An almost twofold increase in the electric field frequency virtually did not influence this activation energy (which only slightly decreased). Thus, a sharp variation in the parameter determining the alternating field acting upon the insulator particles did not result in a comparable change in their binding.

A comparison of the above energy values shows that the polarization activation energy

E_{π} is close to the change carrier activation energy E_2 determined from the temperature dependence of the electric conductivity in the high-temperature region. In addition, as is seen, this value coincides with the thermal ion activation energy in a disordered insulator (0.77 eV). This fact is evidence for the hypothesis that the main contribution to the observed effect is due to the polarization phenomena.

ANALYSIS OF ELASTIC CHARACTERISTICS STABILITY MADE FROM SAV-1 ALLOYS OF FUEL ELEMENTS AT THE WWR-SM REACTOR WITH ULTRASONIC METHOD

I.Kh. Abdukadirova

Institute of Nuclear Physics Academy of Sciences Uzbekistan

izida@inp.uz

At present work analysis were carried out on mechanical properties of some constructional materials, their stability under influence of external factors. Specifically for implementation of the problem put by acoustic methods were attracted.

New information was received on stability of elasticity properties available for reactor technology of constructional materials type of aluminum alloys SAV-1, applied in manufacturing of fuel elements' shell for the

WWR-SM reactor in thermal neutrons using ultrasonic methods. The experiment was carried out in 2008 at the WWR-SM reactor with power 10 Mt and active core fuel loading UO_2 –Al 36% enrichment on U with fuel assemblies IRT-3M type on series on prepared identical samples in the form of disks.

Data on elasticity properties were identified, dispersion dependence of main normal alloy modules before and after action of ionizing radiation on the basis of taken spectrums of bending vibration and their main characteristics: vibrational amplitude (A), resonance frequency (f), and also appropriate calculations.

As an example in table 1 obtained from these spectrums experimental value of resonance frequency $f(m, n)$ for samples are shown.

Table 1. Experimental value of main resonance frequency (kHz) of samples #2.

N	Samples # 1
1	51,837
2	86,125
3	93,325
4	107,106
5	148,462
6	167,994

Based on this and data set of samples and also having publications elasticity value characteristics – coefficient $K(m, n)$ and resonance frequency were considered, elastic parameter of samples are identified by the following formula:

$$f(m,n) = [K(m,n) / d] \cdot [\sqrt{(E/\rho)}] \quad (1)$$

where $f(m,n)$ is resonance frequency, $K(m,n)$ is elasticity coefficient, d and p are diameter of samples and material density, E - modulus of elasticity. As an example calculation results on formula (1) modulus of elasticity of this sample was established and obtained information on variation mode of the elastic characteristics of samples depending on vibration resonance frequency. It's necessary to conclude, that obtained by acoustic method dispersion dependence of the main modulus of elasticity E (f) long term constructional alloy indicates to insignificant of its fluctuations (in table it is shown average value of parameters and appropriate its divergences. Significant stability of elasticity of modules of alloys in ordinary storage conditions, it is observed influence of ionizing radiation dose to it, and it is analyzed possible reasons of exposure of radiation effects.

**IDENTIFICATION METHOD OF EMISSION PEAKS FROM
OXIDE FILM IN THE IR-RANGE WAVELENGTH****E.Yu.Brikulya, B.A.Kalin, I.V.Oleynikov, N.V.Volkov***National Research Nuclear University MEPhI, Moscow, Russia,
e-mail: nvvolkov@mail.ru*

The task of improving the properties of the oxide compounds and stabilization of their structural-phase state are important nowadays, because it is almost impossible to obtain heat-stable, radiation-resistant compounds with specified properties by conventional methods. In this connection, a search for new and efficient methods for producing metal oxides with the desired properties and their control is important and relevant.

One of the objectives of determining the state of protective oxide films is based on the uniformity of their formation on metal surfaces. In case of a violation of the continuity of the formation and the growth of oxide films the resistance of materials to the corrosion processes is greatly reduced. In this context, an algorithm, which processed the measured infrared spectra on reflection (R, %) to identify violations of the continuity of the protective film formed on the metal surface with different modes of ion irradiation, was developed. It was implemented on the basis of spreadsheet EXCEL-2010.

Oxide films were obtained by the oxidation of samples of materials (E110 zirconium alloy) in the steam environment (temperature of 350 ° C, pressure 17 MPa).

The results of processing the IR spectra of the samples using the proposed algorithm made possible the determination of the resonance absorption lines and identification of their respective chemical compounds (OH, H₂O, ZrO, ZrO₂) in samples of all batches.

IR spectroscopy shows the basic ability to detect in oxide films non-uniform local areas in the form of cracks, pores with dimensions of more than 10-50 μm, containing chemical compounds of the Me-O, Me-OH, H₂O, and others.

TO THE QUESTION OF THE ANALYSIS OF EXPERIMENTAL SPECTRA

A. N. Cherepanov

*Ural Federal University named after the first President of Russia
B.N.Yeltsin, Yekaterinburg, Russia, tchustu@mail.ru*

In work the questions concerning the analysis of experimental spectra, such as spectra of emission, excitation of luminescence, absorption, etc. are presented. The method of the offered analysis is based on modeling of experimental curves by settlement curves within some criterion of compliance. Discussion of an essence of criterions of compliance makes the main part of the presented report.

Offered criteria of compliance are constructed taking into account features of the physical processes accompanying process of measurement of the corresponding type of a spectrum. They consider noise processes, processes of quantization of the measured physical size, processes of transformation of a measuring signal.

In work the illustrations of application of an offered method for the analysis of experimental spectra are also given. Examples of its use are shown at research of radiating and optical properties of detector materials.

SAFETY ASSURANCE FOR RESEARCH OF RADIATION HEATING OF MATERIALS UNDER EXPOSURE IN IGR REACTOR CORE

A. T. Izbaskhanova, K. K. Kadyrzhanov, E. A. Kenzhin

Republican State Enterprise “National Nuclear Center of the Republic of Kazakhstan”, Kurchatov, Kazakhstan, E-mail: Izbaskhanova@nnc.kz

The main task under study of radiation heating of constructive materials is the determination of behavior regularity as a result of exposure in research reactor core. Full-scale experimental investigations directly in reactor channels provides with materials testing in conditions of integrated effect of operation factors (wide range of temperatures, strains, neutron flux densities and integral exposure doses). But the pursuance of such investigations is related

to considerable expenses for safety assurance of experimental operations performance.

Safety assurance is reached by development of basic criteria for experimental operations performance with its consequent separation for some stages: pre-reactor, reactor, and post-reactor investigations. Each stage is determined by proper program (or methodology) in which data required for reactor tests (foundation for its performance, technological characteristics, order of tests provision by analytical control, as well as capacity of operative information and methods of its processing) are indicated. In-pile experiments must be supported by numerical analyses using calculation codes, verified upon each concrete reactor at which the performance of such operations are planning to be carried out.

Critical temperature values of tested samples and operational limits of irradiated device constructional materials defined the boundary limits for experimental studies performance.

Calculation analysis of possibility for performance of reactor experiments in set operational limits upon the set exposure parameters, step-by-step preparation of tests and soft hardware for carrying out of technological process are the main requirements for safe performance of experimental operations. Detailed preparation for the experiment with estimated definition of accidents enables to analyze these processes, assess final condition and predict consequences.

Algorithm for safety conduction of experimental works looks as follows: experimental logic setting by safety systems and elements formation, reactor and bench systems start-up preparation in accordance with starting-up program, technical requirements and technological procedure, performance of independent and complex set-up and start-up activities on systems, involved in start-up.

In-pile researches performance, prepared on the basis of numerical solution of multidimensional problem enable to satisfy strict requirements for experimental works safety conduction. Analysis of researches criteria presented in the current work enables to pass along safe route, starting from task setting up to task solving.

IMITATION EXPERIMENTS FOR INVESTIGATION OF REACTOR MATERIALS RADIATION HARDNESS

**T.V. Kulevoy, B.B. Chalykh¹, R.P. Kuybeda², N.Yu. Grachev³,
A.A. Aleev⁴, A.A. Nikitin⁵, N.A. Iskanderov⁶, N.N. Orlov⁷,
A.D. Fertman⁸, S.V Rogozhkin⁹**

*Institute of Experimental and Theoretical Physics, Moscow, Russia,
kulevoy@itep.ru.*

¹*Institute of Experimental and Theoretical Physics, Moscow, Russia,
4alihx@gmail.com.*

²*Institute of Experimental and Theoretical Physics, Moscow, Russia,
kuibeda@itep.ru*

³*Institute of Experimental and Theoretical Physics, Moscow, Russia,
grachz57@gmail.com.*

⁴*Institute of Experimental and Theoretical Physics,, Moscow, Russia,
Andrey.Aleev@itep.ru.*

⁵*Institute of Experimental and Theoretical Physics, Moscow, Russia,
aleksandr.nikitin@gmail.com*

⁶*Institute of Experimental and Theoretical Physics, Moscow, Russia,
Nasib862007@yandex.ru*

⁷*Institute of Experimental and Theoretical Physics, Moscow, Russia,
Toolup@yandex.ru.*

⁸*Institute of Experimental and Theoretical Physics, Moscow, Russia,
fertman@itep.ru*

⁹*Institute of Experimental and Theoretical Physics, Moscow, Russia,
Sergey.Rogozhkin@itep.ru*

Intensive development of nuclear energetic determines a necessity for investigations of reactor materials radiation damaging under ionizing radiation. The main goal of the experiments is an understanding of defects generation and development in material under high dose irradiation. Investigations are carried out with existing materials and with new materials that can be used for nuclear facilities. Under neutrino irradiation the defects formation in a structure has a low speed ($\sim 10^{-6}$ displacement of atom per second - dpa), therefore a period of irradiation needed is calculated in years. From one hand, low speed of defects formation is a good factor for reactor industry but results a lot of problems for studying of a radiation damages in materials.

Using an accelerated ion beams for irradiation imitation has an advantage for the material investigation since beam ions have significantly

higher cross-section for interaction with material than the neutrino one. As result the required number of dpa can be obtained by the reasonable time. Also the ion beams have another advantages related to the methodological side of imitation experiments. The absence of induced radioactivity enables samples investigation after irradiation with ordinary experimental equipment. In Institute of Experimental and Theoretical Physics the modeling experiments simulating the reactor materials irradiation by ion beam are going on at heavy ion RFQ injector. The modern atom probe tomography is used for irradiated samples investigation. The results of imitation experiments with steels RUSSREF-181 and ODS- Eurofer are presented.

EXPERIMENTAL CHANNEL COMMISSIONING AND FIRST EXPERIMENTS FOR MATERIAL IRRADIATION AT HEAVY ION RFQ IN ITEP

T.V. Kulevoy, B.B. Chalykh¹, R.P. Kuybeda², A.A. Aleev³, A.A. Nikitin⁴, N.N. Orlov⁵, S.V Rogozhkin⁶

*Institute of Experimental and Theoretical Physics, Moscow, Russia,
kulevoy@itep.ru.*

¹*Institute of Experimental and Theoretical Physics, Moscow, Russia,
4alihx@gmail.com.*

²*Institute of Experimental and Theoretical Physics, Moscow, Russia,
kuibeda@itep.ru*

³*Institute of Experimental and Theoretical Physics,, Moscow, Russia,
Andrey.Aleev@itep.ru.*

⁴*Institute of Experimental and Theoretical Physics, Moscow, Russia,
aleksandr.nikitin@gmail.com*

⁵*Institute of Experimental and Theoretical Physics, Moscow, Russia,
Toolup@yandex.ru.*

⁶*Institute of Experimental and Theoretical Physics, Moscow, Russia,
Sergey.Rogozhkin@itep.ru*

To date, about half of the world's energy balance accounts for oil, a little less than a third - the share of natural gas and nuclear power (about one-sixth each) and about one-fifth - the share of coal. All other energy sources account for only a few percent. These percents include power generation devices based on renewable sources of energy that operate using solar energy, wind,

tides, sea waves, as well as underground heat of the planet. Nevertheless the implementation of energy projects with renewable sources in Russia and around the world requires huge investments, therefore it is too early to hope that they substitutes hydrocarbon. As result, it looks like nuclear energy is the most promising alternates for hydrocarbon. But one of the key issues on this way is the safety of nuclear power reactors. To establish the fundamental lows of changes in the structure and properties of materials used in reactor construction, to predict their behavior in reactor cores, the particle accelerators are widely used. Accelerated ion beams are used to simulate radiation damage in metals and alloys investigated.

In Institute of Theoretical and Experimental Physics imitation experiments with ion beam accelerated in heavy ion RFQ HIP (Heavy Ion prototype) started this year. The results of experimental channel commissioning are presented. As well the results of first irradiation experiments are given.

**MODELLING OF PASSAGE OF OPTICAL SIGNALS THROUGH
RECORDING SYSTEM IN THE ENVIRONMENT
OF LabVIEW**

V. M. Lisitsyn, E.F. Polisadova, D.T. Valiev

National Research Tomsk Polytechnic University, Tomsk, Russia
dtdamir@sibmail.com

Dynamics of changes in the parameters of optical signals initiated by a short pulse excitation, gives important information about the processes of transformation of point defects, about the mechanisms of evolution of the electronic excitations, the energy dissipation in the material. An important parameter that reflects these physical processes may be the kinetic changes in the optical transmittance after the excitation pulse.

Simulation of the passage of signals through dynamic links in the recording system using the convolution integral, have been implemented in software in a graphical programming environment LabVIEW, using the module MathScript. Built-in function was used to perform the convolution of the instrumental function and the input signal, such as *conv*. The basis of the software emulator of the signal through a linear dynamic system, the signal generator was implemented in the structure of the MathScript Node, which formed the input signal with a specified time range. In which it was necessary

to take into account the magnitude of the sampling frequency, which makes a change in the amplitude of the output signal. The input signal is assigned in the form of two exponentials.

In the course of studies varied timing of growth and decay of the signal. At the output terminal structure MathScript Node, formed one-dimensional array of numeric values, which was fed to the first terminal of the function 1D Convolution.vi. On the second terminal of the apparatus function was applied. The calculated data are fed to a graphical indicator *Waveform Graph*. As a basic element for the model of the instrumental function we have chosen a signal representing the sum of two exponential functions. Since this model is closest to the real conditions. In most cases the response of the system on a single instantaneous pulse can be represented as the sum of two components consisting of the rise time and fall time, which in many cases are described by an exponential law:

$$h(t) = A * (\exp(-t/\tau) - \exp(t/RC))$$

where A is the amplitude coefficient, τ - the rise time of the response function of the system defined by the reaction of a photomultiplier and an oscilloscope to the input signal, R and C-parameters of the recording chain. The values of R and C was chosen on the basis of the requirements for time resolution and sensitivity of the system. The time resolution of the system is known to be proportional to the product of R and C.

Simulation in LabVIEW MathScript with the module using the convolution integral, taking into account the parameters of detecting RC-chain, reflects real changes in the recorded signals. Demonstrated the dynamics of changes in the amplitude of the signal from the load resistance of the recording chain. Application of the models will be important for areas related to the change of signals with high temporal resolution.

**PULSED CATHODOLUMINESCENCE OF MINERALS
EXCITED BY NANOSECOND AND SUBNANOSECOND
ELECTRON BEAMS**

**V. M. Lisitsyn¹, V. F. Tarasenko², E. F. Polisadova¹, E. H. Baksht²,
D. T. Valiev¹, A. G. Burachenko², Lipatov E.I.²**

¹*Tomsk Polytechnic University, Tomsk, Russia*

²*High Current Electronics Institute, SB RAS, Tomsk, Russia*

Research on the luminescence of minerals due to ionizing radiation is an important field in spectral analysis of solids that allows determination of the chemical composition of material, its structure (the presence of defects), phase structure, state (internal stress), etc. The development of compact electron accelerators makes it possible to have a significant increase in the peak intensity of the cathodoluminescence induced by electron beam and allows the pulsed cathodoluminescence (PCL) characteristics of various solids (including minerals) to be studied under the action of electron beams. The technique of time-resolved spectrometry is implemented most commonly with using of accelerators with vacuum diodes (type GIN-600). These accelerators produce electron beams of varying energy, current density, and pulse duration: the beam current pulse duration is varied by varying the voltage pulse parameters; the electron energy in a vacuum diode is determined by the voltage across the inter-electrode gap. Duration of a pulse on a half-height can make from 3 to 30 nanoseconds, the excitation density can be changed in a range from 10^5 to 10^8 W/cm² [1]. To increasing of time resolution is need to use more short pulses. In this case, electron accelerators (type SLEP-150) with gas diodes are more preferable to use; they are simpler in design and make it possible to produce an electron beam of current density 100 A/cm² and to control the pulse duration in the range from 100 to 500 ps [2].

In this work, experiments were performed on two electron accelerators with vacuum and gas diodes. The objective of the present paper was to study the emission spectrum and decay kinetics of PCL for calcites from different deposits, two specimens of diamond (natural and synthetic) excited by nanosecond and subnanosecond electron beams.

[1]. Korepanov V. I.; Lisitsyn V. M. and. Oleshko V. I. (2000). Russian Physics Journal, Vol.43, pp. 185-192. ISSN 0021-3411.

[2]. Tarasenko V.F.; Baksht E.K.; Burachenko A.G.; Kostyrya I.D.; Lomaev M.I. and. Rybka D.V. Plasma Devices and Operation. 2008, 16, 267-298.

**THE INTERRELATION BETWEEN THE THERMODYNAMIC
AND OPTICAL PARAMETERS OF DBD-DRIVEN XeCl-EXCILAMP:
MODELING AND EXPERIMENT**

E. A. Sosnin^{1,2}, S.V. Avtaeva³, V. A. Panarin¹, S. M. Avdeev¹

¹ *Institute of High Current Electronics SB RAS, Tomsk, Russia,
badik@loi.hcei.tsc.ru*

² *Tomsk State University, Tomsk, Russia*

³ *Kyrgyz-Russian Slavic University, Bishkek, Kyrgyz Republic,
s_avtaeva@mail.ru*

The radiative and thermodynamic parameters of a dielectric barrier discharge (DBD) XeCl-excimer lamp were studied. Experiments were performed with a double-barrier coaxial lamp in mixture Xe:Cl₂ = 240:1. The DBD was initiated by applying voltage pulses with an amplitude of up to 5 kV and a repetition rate of 65.7 kHz to the electrodes.

The radiant efficiency was determined by modeling and from experiment. For this aim the DBD in XeCl-excimer lamp was simulated within the limits of the 1D fluid model. The DBD characteristics are described based on the continuity equations for electrons and ions, balance equations for neutral species, the Poisson equation and an equation for the external electric circuit. Experimentally the power consumed by the excimer lamp was estimated using oscillograms of voltage and current pulses.

To explain the disagreement between theoretical and experimental radiant efficiency values of XeCl-excimer lamp the thermodynamic concept of lamp was used. For this aim the fast components of a pressure jump arising during the operation of an excimer lamp are recorded, and the gas mixture is considered as a thermodynamic system whose temperature increases at a constant volume (an isochoric process).

This work was supported the RFBR grant No. 12-08-00020-a.

**STUDY OF ACOUSTIC VIBRATIONS OF DBD-DRIVEN
PLANAR KRCL-EXCILAMP**

E. A. Sosnin¹, V. A. Panarin¹, A. A. Pikulev², V. F. Tarasenko¹

¹ *Institute of High Current Electronics SB RAS, Tomsk,
badik@loi.hcei.tsc.ru*

² *Russian Federal Nuclear Center-All-Russian Scientific-Research Institute of Experimental Physics, Sarov, Russia, pikulev@expd.vniief.ru*

The theoretical and experimental study of acoustic characteristics of dielectric barrier discharge KrCl-excilamp filled by Kr:Cl₂ = 400:1 gas mixture at the total pressure 20 kPa has been carried out. The resonances at frequencies of 4.96, 5.36, 9.92, 10.8 and 21.6 kHz during experimental measurements of a acoustic vibrations spectrum has been obtained. The modeling of characteristic oscillation of lamp walls and of gas media and the energy of acoustic fluctuations via wall fluctuation frequency has been carried out. The comparison of theoretical and experimental results has shown, that in the field of $f > 10$ kHz the maxima of an acoustic signal coincide with characteristic oscillation of gas media.

This work was supported the RFBR grant No. 12-08-00020-a.

**INSTITUTE OF HIGH TECHNOLOGY PHYSICS EXPERIENCE IN
MASTERS OF ENGINEERING AND DOCTORAL TRAINING: THE
PLATFORM FOR COOPERATION WITH RUSSIAN ACADEMY OF
SCIENCES INSTITUTIONS IN THE DOMAIN OF MATERIAL SCI-
ENCE AND PHYSICS OF HIGH ENERGY SYSTEMS**

**A. N. Yakovlev, K. S. Kostikov, N. V. Martyushev,
N. A. Shepotenko, Yu. V. Falkovich**

*National Research Tomsk Polytechnic University
kostikov@tpu.ru*

The 21st century happened to be the new stage of development in Russia. Its government has started to implement the reforms in all spheres of human endeavor. The educational system has been changed dramatically. On the one hand, the competitive environment where there are a lot of higher ed-

educational establishments of different levels has been formed. On the other hand the economic situation has predetermined the requirements to the level of professional training and University alumni. They are required to have a set of professional competences that give them an opportunity to adapt in the industrial conditions, ability to acquire new knowledge quickly, to work in a team, to apply new types of equipment and technologies e.t.c. This makes Universities develop new innovative approaches to the educational training, sophisticated methods of addressing the challenges, maintain close cooperation between scientists, businesses and government.

Tomsk Polytechnic University was awarded the status of National Research in 2009. This was due to its high educational and research potential as well as intensive work on implementation of new techniques and methods into training process.

One of the techniques is so called “transparent education” or CDIO concept (CDIO is initialism for Conceive — Design — Implement — Operate) The framework provides students with an education stressing engineering fundamentals set in the context of Conceiving — Designing — Implementing — Operating real-world systems and products. Throughout the world, CDIO Initiative collaborators have adopted CDIO as the framework of their curricular planning and outcome-based assessment. In 2011 National Research Tomsk Polytechnic University joined the global CDIO Initiative. This approach is used in the Institute of High Technology Physics while developing two Bachelor Programs. They are Chemical Engineering and Industrial Machines and Equipment.

To a considerable extent the competences development is predetermined by students’ involvement into innovative and research processes. The greater result is achieved by their participation in real time projects that are funded by industrial enterprises, through grants and Federal Specific Program.

The joint programs are implemented in close cooperation with Institutions, Russian Academy of Sciences. Fundamental disciplines are taught at TPU whereas the fundamental knowledge is applied and put into practice at different Institutions. This gives students an opportunity to take part in the cutting-edge research projects under the guidance of mature scientists. While working at laboratories students can get valuable experience in design and experimental engineering work that is an integral part of industrial and research enterprises careers. By the same token the high motivation to earn money and feel the success of the real work is a great impetus for students to study better.

The quality of the education where above mentioned approaches are used has been proved by a number of foreign students who are studying and

willing to study at the Institute of High Technology Physics. The first Doctor of Science degree awarded to a foreign researcher at TPU and in Tomsk was given to Kensuke Uemura, Japan. He defended the thesis “Development and Research of Beam and Plasma Method to Enhance the Performance of Metal Tools”.

**RESEARCH WORK OF STUDENTS AS THE PLATFORM
FOR DOCTORAL EDUCATION**

**A. N. Yakovlev, K. S. Kostikov, N. V. Martynushev,
N. A. Shepotenko, Yu. V. Falkovich**

National Research Tomsk Polytechnic University

kostikov@tpu.ru

It is of common knowledge that research and technological developments as well as intellectual and educational potential of the staff is the bases of economic and social development of any country. National Research Tomsk Polytechnic University (TPU) was one of the first Universities to follow the way. The status of National Research Universities awarded to TPU has determined research priorities thus being a prerequisite to set up the structures aimed at these priorities implementation. By the same token a greater attention has been drawn to young researchers, bachelor and master degree students involvement into the research work. This has given the great impetus to restructure the department that is in charge of work with young researchers and to improve the system of such work among members of the faculties. One more key factor has been the change of overall TPU administrative structure. The departments have been transformed into Institutes that contain a variety of departments and research laboratories in different domains.

The distinctive feature of new TPU structure is to offer innovative education that implies integration of interdisciplinary and project-oriented technologies with elite training based on the science traditions of specialists training.

The managers responsible for research work of students are to address the following challenges:

- to involve students in the science activities at the first stages of their higher education;
- to establish human resources potential and provide students with effective research supervisors;
- to motivate students to be involved in research work;
- to provide students and young researchers with comprehensive relevant information, proper funding and methodological bases;
- to organize individual pathways for young researchers that will further professional competences development.

The following challenges are being addressed within the framework of Institutes by means of elite technical education, supervisors community, school of young researchers, stimulating and financial measures e.t.c.

One of the priorities is to involve students in the science activities. The case study of Institute of High Technology Physics shows the outcomes of effective communication of would be young researchers with supervisors and students who are in charge of the fellows. Individual supervising of every talented student at all educational stages can foster intensified research activity. Each student is supervised by a professor who helps find the right area of interests. To participate in research activities means to develop understanding of lifelong education process. A student learns how to reach the highest career potential while participating in Olympiads, conferences and contests.

The most important thing to expand the research framework is to provide its diverse stimulation. The stimulating factors are certificates, University community recognition awards, references to whom it may concern as well as funding practices such as individual scholarships and grants, bonuses and perks, trips to foreign countries to take part in the international fora and conferences, being a member of University Staff Promising Group. Besides, the most devoted students are included in the Conference organizing committees and are appointed to be in charge of their fellows.

17th
International Symposium
on High Current Electronics

**GENERATION OF ELECTRON BEAMS WITH CURRENT
PULSE DURATION OF 10^{-5} S IN VACUUM DIODE
WITH PLASMA ANODE**

E. N. Abdullin, A.V. Morozov

*Institute of High Current Electronics SB RAS,
2/3, Akademicheskoy ave., Tomsk, 634055, Russia, E-mail:
abdullin@lhfe.hcei.tsc.ru*

Duration of electron beams obtained in the diodes with explosive emission cathodes is limited by breakdowns due to the interelectrode gap filling with plasma formed at the explosion of micropoints at the cathode and formed as well at the anode under the electron beam influence. Increase of the current pulse duration of electron beams is of interest for increasing their energy and expansion the electron beam application in the field of surface thermal treatment of materials.

To increase the duration of electron beams, the vacuum diodes with multipoint cathodes and plasma anode are used. Application of multipoint cathodes allows distributing the beam current to a large number of emitting points, decreasing concentration of the cathode plasma and the rate of its arrival in the interelectrode gap. Application of the plasma anode with artificially created anode plasma decreases dependence of the interelectrode gap conductivity on the plasma formed under the electron beam influence and arriving from the anode and vacuum chamber walls. Electron sources with plasma anode find application for generation of the microsecond electron beams with electron energy of $\sim 20-40$ keV and current density up to 1 kA/cm^2 .

Possibility to increase the electron beam energy as well as to control the current and beam current pulse duration by changing the diode configuration and current pulse parameters of plasma guns was investigated in the present work. At the diode voltage up to 120 kV, the electron beams were generated having the diameter up to 8 cm, beam current up to 2 kA, current density up to 40 A/cm^2 , duration of 5-15 μs , energy density up to 25 J/cm^2 .

MODELING OF MAGNETIC FIELD OF VACUUM DIODE WITH RETURN CURRENT CONDUCTORS

E. N. Abdullin, A.V. Morozov

*Institute of High Current Electronics SB RAS,
2/3, Akademichesky ave., Tomsk, 634055, Russia, E-mail:
abdullin@lhfe.hcei.tsc.ru*

Magnetic field of a vacuum diode resulting in curvature of electron trajectories at the beam edge is one of the main factors limiting the amount of the diode current.

To decrease the magnetic field influence on the beam forming, the diode sectioning is used: a diode is divided into a number of diodes isolated magnetically from each other with a reasonable magnetic field value. This division can be reached as a result of direct replacement of an electron accelerator by the accelerators with lower electron currents. Common variant of sectioning is to install into the diode the return current conductors in the form of the plates performing magnetic shielding of the diode parts relative to each other. A drawback of sectioning is necessity to provide essential interelectrode gaps between the cathodes and grounded cases of the accelerators or return current plates, to arrange the current supply to the cathodes of magnetically shielded diodes that is related to essential changes of the design and enlargement of the diode dimensions.

The paper considers the possibility of reducing the magnetic field diode by placing return current conductors in the form of small-dimensional rods directly in the diode. The diode division in this case takes no place; magnetic field decrease is achieved by addition of the diode magnetic fields with magnetic fields of the return current conductors and current redistributions. The advantage of the approach is that the installation of the rods requires no essential changes of the diode configuration and dimensions. Results of numerical simulation as well as physical modeling of the diode magnetic field are presented here.

**CONCEPTUAL DESIGN AND NUMERICAL SIMULATION
OF LONG-PULSED 1-kA ELECTRON BEAM SOURCE
FOR OPEN MAGNETIC TRAPS**

**V. T. Astrelin^{1,2}, A. V. Burdakov^{1,3}, I. V. Kandaurov¹,
I. E. Karpov², Yu. A. Trunev¹**

¹*Budker Institute of Nuclear Physics SB RAS, Novosibirsk, Russia,
Astrelin@inp.nsk.su*

²*Novosibirsk State University, Novosibirsk, Russia,
iekarpov90@gmail.com*

³*Novosibirsk Technical State University, Novosibirsk, Russia,
Burdakov@inp.nsk.su*

Experiments [1] on heating of a dense plasma by powerful electron beam of $\sim 10^{-5}$ s duration in the multiple mirror trap GOL-3 have shown good perspectives to reach thermonuclear temperatures by this way. Moreover, it seems that there is a real possibility to use a beam with longer duration but less power for plasma heating and to elongate confinement time of hot plasma [2]. However, for realization of this possibility one must develop an electron beam injector of a millisecond range. This report presents the conceptual design of the injector for multimirror magnetic trap. The trap will be used as an experimental stand for testing of plasma facing materials for future fusion reactors.

Injector parameters are determined by the requirements for the designed stand: the electron energy ~ 100 keV, the beam diameter ~ 4 -5 cm and current up to 1 kA in the magnetic field of 7 T in the trap. The beam source will operate in a mode of 1-ms package of short 2-5 ns pulses with duty factor ~ 0.1 . A guiding convergent magnetic field increases from 0.02-0.05 T to 7 T for the beam compression in 200-300 times and its injection into the trap. A contradictory requirement on the current density ~ 1 kA/cm² can be met using filament-like beam structure.

The injector is based on the earlier studied [3] diode source based on the plasma emitter. The plasma is produced by a pulsed arc discharge in hydrogen gas inside the cathode volume (expander) and forms an emission surface at the boundary of a diode gap. Electrons are extracted from the plasma surface through small openings on the flat multiaperture cathode electrode in the mode of the open plasma boundary. The accelerated beam consisting of separate beamlets, is transported and compressed in the guiding magnetic field to the required current density.

The paper presents a general scheme of the trap with the beam injector and results of a two-dimensional computer simulation of the single beamlet in the diode to select the optimal configuration of electrodes. A feature of the numerical model is the calculation technique for emission plasma surfaces shape, taking into account the backflow of plasma from the trap incoming into the diode gap through the anode apertures. The analysis of the permissible ranges of the cathode and anode plasmas parameters was also performed.

This work was done under financial support from the Russian Ministry of Education and Science, by Grant № 11.G34.31.0033 of the Russian Federation Government, by RFBR Grant 10-08-00-707 and Interdisciplinary Integration Project of SB RAS No 104.

1 V.S. Koidan, A.V. Arzhannikov, V.T. Astrelin, et al. Progress in multimirror trap GOL-3 // Fusion science and technology, Vol.47, No.1T, 2005, p.35-42.

2 A.V. Burdakov, A.V. Arzhannikov, V.T. Astrelin, et al. Concept of Fusion Reactor Based on Multi-Mirror Trap. // Fusion Science and Technology, V.59, No 1T, 2011, p.9-16.

3 I.V. Kandaurov, et al. Study of Intensive Long-Pulse Electron Beam Generation in a Source with Arc Plasma Emitter Operated in an External Magnetic Field. // Proc. of 15th Intern. Symp. on High Current Electronics: Tomsk, 2008, p.121-124.

A REPETITIVE SOURCE OF PULSED ELECTRON BEAMS

**I. S. Egorov, G. E. Remnev, M. I. Kaikanov, E. I. Lukonin,
V. S. Esipov, A. V. Poloskov, D. Yu. Kolokolov**

*Institute of High Technology Physics at TPU, Tomsk, Russia, E-mail:
egoris@tpu.ru*

The “ASTRA-M” high-repetition rate pulsed electron beam source has been developed for the radiation treatment of water solutions. The paper presents a description of the construction, principal of operation and the operational characteristics of the accelerator. An electron diode with a metal-ceramic cathode is driven by a capacitive storage system, which is discharged through a pulsed step-up transformer. The parameters of the electron beam are: the maximum kinetic energy is up to 475 keV, the half-height pulse dura-

tion of an ejected beam is 75 ns, the energy transferred by the beam is up to 10 J.

The paper also presents experimental data on the accelerator tested in continuous operation at a rate of 40 pulses/second. A heat operational mode of the equipment and shot-to-shot stability have been analyzed. The capabilities of an automatic control system for the accelerator as well as a built in X-ray protection system are discussed.

**INVESTIGATION OF THE PLASMA EMITTER BASED ON
THE REFLEX DISCHARGE WITH A CATHODE SPOT FOR IN-
TENSE SUB-MILLISECOND ELECTRON BEAM**

S. V. Grigoryev, P. V. Moskvina, A. D. Teresov

*Institute of High Current Electronics SB RAS, Tomsk, Russia,
grigoriev@opee.hcei.tsc.ru*

The results of investigation of the plasma electron emitter based on reflective discharge with cathode spot are presented.

In the discharge cell of plasma cathode electron gun "Solo" was implemented reflective discharge with cathode spot. Cathode-reflector was emission electrode with a grid. The cathode-reflector was connected either through resistor R, or directly to the main discharge cathode circuit. The induction of the magnetic field in the annular anode reflex discharge in the experiments was 20-30 mT. In the experiments, there was multiple plasma cathode current amplification at the generation electron beam with energy of 20 keV. The oscillograms was evident that the current in the accelerating gap exceeds a multiple of the plasma cathode discharge current (50 A and 200 A respectively). In some cases, it was possible to obtain a 6-fold excess, and is not there a current increase depends on the operating pressure. While with increasing accelerating voltage beam current is increased significantly. This mode of electrons generation substantially different from the beam current amplification due to ion-electron emission. We can assume the following mechanism of the emitter operation. The connection of the emission grid and the cathode of the discharge with a high negative potentials at an accelerating voltage leads to current increasing preliminary created cathode spot (40-50 A) by the source of the accelerating voltage. Dense plasma of the cathode spot closes the accelerating gap at the cathode of the discharge, while in the

emission electrode on a "rare" gas-discharge plasma accelerating gap is formed. It was found that even a small increase in the plasma cathode discharge current (from 50 to 60 A) there is a breakdown of the accelerating gap. This indicates a very pronounced dependence of the electron emission mode from the discharge current in the cell plasma cathode. When setting the resistance R, the emission current was limited to this resistance and at the 2,4 Ohm emission current does not exceed current main discharge.

FORMATION OF CHARGE – EXCHANGE NEUTRAL ATOMS IN A DIODE WITH PASSIVE ANODE

Yu.I. Isakova, A.I. Pushkarev, I.P. Khaylov

*Institute of High Technology Physics at TPU, Tomsk, Russia,
aipush@mail.ru*

The paper presents an experimental evidence of the formation of energetic charge-exchange neutral atoms in a self-magnetically insulated diode with a graphite potential electrode. The experiments have been carried out using both a diode with externally applied magnetic insulation (single-pulse mode: 100 ns, 250-300 kV) and a diode with self-magnetic insulation (double-pulse mode: the first negative pulse 300-500 ns, 100-150 kV followed by the second positive pulse 150 ns, 250-300 kV). The ion beam energy density was measured using an infrared imaging diagnostics of thin metal targets, which intercept the beam. It was also calculated using the waveforms of ion current density and accelerated voltage.

A disagreement between experimental and calculated values of the beam energy density was found for a case with the self-magnetically insulated diode. The ion beam energy density measured and calculated for the applied B diode was in a good agreement and found to be 3.6-4 J/cm², whilst the measured results (infrared camera method) for the self-magnetically insulated diode differ by a factor of 4-6 from the calculation (waveforms of ion current density and accelerating voltage). This is attributed to the formation of neutrals in a diode as a result of charge exchange processes between accelerated ions and molecules of residual gas. Neutral atoms can not be registered by Faraday cup charge collectors, but still contribute to heat of the target, which is measured by an infrared camera. In the diode with self magnetic insulation, operating in a double pulse mode, the charge-exchange processes proceed

more effectively compared to the applied B filed diode, operating in a single pulse mode. The presence of a time interval (in double pulse mode) between a moment of desorption of molecules from the anode surface and a moment of ions generation increases the thickness of a layer of desorbed molecules. This leads to an increase in the number of charge-exchange acts for an ion. The ability of production of large fluxes of energetic neutrals in an ion diode with self-magnetic insulation was shown. With the energy of neutrals of 3-5 keV, the fluence can reach up to $(2-4) \cdot 10^{15} \text{ cm}^{-2}$ per pulse.

SELF-OSCILLATORY MODE OF ELECTRON BEAM GENERATION IN A SOURCE WITH A GRIDDED PLASMA CATHODE

A.S.Kamenetskikh, N.V.Gavrilov

*Institute of Electrophysics of the Ural Branch RAS, 106 Amundsen St.,
620016 Ekaterinburg, Russia
tel.: (343) 2678778, Fax: (343) 2678794, e-mail: alx@iep.uran.ru*

Emission of the plasma cathode on the basis of the glow discharge with a hollow cathode and an expanded anode part at conditions of argon pressure of 0.1-0.8 Pa was investigated. Electrons were extracted from the anode plasma through channels of the millimetric sizes in an anode grid by application of accelerating voltage of 50-300 V. Oscillograms of electron beam current and a floating potential of a probe in anode plasma were recorded and energy spectrums of electrons at beam currents of 0,5-2,5 A were measured. It was shown, that broadening (from above 100 eV) of the electron spectrums with a rise of beam current and gas pressure is caused by transition of the plasma cathode in a self-oscillatory mode with frequency of fluctuations of beam current and plasma potential within 10-100 kHz and modulation of the current and the potential values up to 60 %. The mode of self-oscillations arises at high efficiency of electron extraction and is caused by instability of a double charge layer in apertures of the anode grid at increase in emission current density in apertures of the grid and a simultaneous voltage drop reduction across the layer.

**HIGH POWER (10 MW), LONG PULSE MULTIAPERTURE
ELECTRON BEAM INJECTOR WITH PLASMA EMITTER
DESIGNED FOR BEAM-PLASMA EXPERIMENTS**

**I. V. Kandaurov, V. T. Astrelin, A. P. Avrorov, A. V. Burdakov,
P. V. Bykov, G. E. Derevyankin, A. A. Ivanov, I. A. Ivanov,
V. V. Kurkuchekov¹, S. V. Polosatkin, A. F. Rovenskikh, Yu. A. Trunev**

Budker Institute of Nuclear Physics of SB RAS, Novosibirsk, Russia

¹*Novosibirsk State University, Novosibirsk, Russia*

e-mail: i.v.kandaurov@inp.nsk.su

The long pulse source of intense electron beam was developed and built at BINP for the experiments on beam injection in linear plasma devices. Electrons are extracted from a plasma of the pulsed arc discharge in hydrogen. The beam is accelerated with multi-aperture diode-type electron optical system. The cathode and anode of the diode are performed as planar molybdenum «grids» with 241 round openings arranged in a hexagonal pattern. The openings are aligned coaxially with high accuracy during the diode assembly. The source is designed to operate with an accelerating voltage of up to 150 kV, in external magnetic field of 10 - 100 mT. The diode optics allows to compress the beam in adiabatically converging magnetic field at least 100-fold.

The injector was installed into the end tank of the GOL-3 multiple mirror trap and tested to produce an electron beam with up to 100 keV electron energy, 100 A total beam current in the submillisecond pulse duration range. In a series of first experiments the beam was injected into the GOL-3 plasma chamber filled with deuterium gas with a density of 10^{14} - 10^{15} cm⁻³ and transported in a corrugated magnetic field ($\langle B \rangle$ up to 1.4 T) along the trap at a distance of 12 m. The beam transport and compression was registered with a visible light fast cameras and x-ray pinhole camera.

This work is financially supported by Russian Ministry of Education and Science, RFBR Grant No. 10-08-00707a and Interdisciplinary Integration Project of SB RAS No 104.

**THE USE OF FERROMAGNETIC INSERTS FOR CONTROL
OF THE ENERGY DENSITY PROFILE OF HIGH-CURRENT
ELECTRON BEAM**

K.V. Karlik, L.A. Zyl'kova, G.E. Ozur

*Institute of High Current Electronics, Tomsk, Russia,
karlik@lve.hcei.tsc.ru*

The control of the energy density distribution of low-energy (10-30 keV), high-current (10-30 kA) electron beams used for material surface treatment represents a traditional actual problem. To produce such beams, the high-current guns with explosive-emission cathode and plasma anode based on high-current reflective (Penning) discharge are generally used. Investigations and experience of the exploitation have shown that the beam uniformity (one of the key parameters) via its cross section still left much to be desired because of the maximum in the central part of the beam appearing when it is transported through plasma channel in a guide magnetic field.

To improve the beam uniformity, we suggest the redistribution of the beam energy density using ferromagnetic inserts placed just behind the collector. These inserts constrict the guide magnetic field lines to themselves. Changing the sizes of the inserts and their magnetic permittivity, it is possible to control the beam radial profile and to focus it. However, some part of the beam may be reflected from the magnetic mirror. But fortunately, our experiments have shown that the beam current does not decrease in comparison with the case of uniform guide magnetic field. The computer calculations of the magnetic field configuration are in good agreement with experimental data on changing the beam diameter in dependence on the diameter and the length of the insert.

**A COMPACT CALORIMETER BASED ON A MAGNETICALLY
INSULATED FARADAY CUP FOR INTENSE ION BEAM
DIAGNOSTIC**

I.P. Khailov, Yu.I. Isakova, A.I. Pushkarev

*Institute of High Technology Physics at TPU, Tomsk, Russia,
E-mail: bastrik@sibmail.com*

We have developed a device which allows for a simultaneous measurement of both current density and energy density of an intense ion beam. The device is composed of a magnetically insulated Faraday cup and a micro-calorimeter, both are located in one magnetic system. A charge collector in the Faraday cup is also a calorimeter, the temperature of which is measured by a thermal resistor. A pair of permanent magnets ($B=0.4$ T) is used at the device entrance in order to filter low-energy electrons accompanying the ion beam, providing an accurate measurement. The device was tested with an intense ion beam formed by a self-magnetically insulated diode. The experiments were carried out with the TEMP-4M accelerator operating in double-pulse mode: the first pulse is of negative polarity (300-500 ns, 100-150 kV), and this is followed by a second pulse of positive polarity (150 ns, 250-300 kV). The energy density of the ion beam was measured by the calorimeter and with the calculations made from the experimental values of the ion current density and accelerating voltage. The device was specially designed to study the formation of charge-exchange neutral atoms in diodes with a passive anode.

CAPACITOR BLOCKS FOR AIR INSULATED LTD STAGES

**A.V. Kharlov, B.M. Kovalchuk, E.V. Kumpyak, N.V. Tsoy,
G.V. Smorudov**

*Institute of High Current Electronics, Tomsk, 634055, Russia,
akharlov@lef.hcei.tsc.ru*

Linear Transformer Driver (LTD) technology was pioneered by the Institute of High Current Electronics in Russia more than a decade ago. In the Linear Transformer Driver technology, the low inductance energy storage

components and switches are directly incorporated in the individual cavities (named stages) to generate a fast output voltage pulse which is added along a vacuum coaxial line like in an inductive voltage adder. Typically primary side of induction cavities is filled with transformer oil for additional electrical isolation of the components. It is often not desirable to use oil and especially rise problems in large assemblies. LTD stages with air insulation were introduced in [1]. Dry air is used both as insulation in the stages and as working gas in the LTD spark gap switches, providing easy handling and maintenance.

Special unit, named capacitor block, was developed for use as a main structural element of such transformer stages. It incorporates two capacitors GA 35426 (40 nF, 100 kV) and multichannel multigap gas switch. Amount of capacitor blocks (and respectively gas switches) could be very large in LTD stages assemblies (192 blocks in electron accelerator for THL-100 laser in IHCE, for example). It implies very strong requirements on self breakdown probability of the switches, which should be extremely low. Several modifications of the capacitor blocks were developed and tested on life time and self breakdown probability both as separate units and in assembly of capacitive module from 5 capacitor blocks.

This report presents detailed design of capacitor blocks, description of operation regimes, numerical simulation of electric field in the switches and test results.

1 B.M. Kovalchuk, A.V. Kharlov et al., "40 GW linear transformer driver stage for pulse generators of megaampere range," *Laser and Particle Beams*, vol. 27, pp. 371–378, September 2009.

HIGH-CURRENT ELECTRON GUN WITH PLASMA ANODE BASED ON COMBINED DISCHARGE

P.P. Kiziridi, G.E. Ozur

*Institute of High-Current Electronics, SB RAS, Tomsk, Russia,
kiziridi_pavel@mail.ru*

Low-energy (20-40 keV), high-current (10-30 kA) electron beams (LEHCEBs) are of great interest for material surface treatment and have already found rather wide use in practice. To produce LEHCEBs, electron guns

with explosive-emission cathode and plasma anode based on high-current reflective (Penning) discharge and are generally used. Investigations and experience on exploitation of such guns have shown that the uniformity of beam energy density distribution in cross section left much to be desired because the beam being even uniform in the injection plate acquires a maximum of energy density in the central part after transportation through plasma channel.

To improve the beam uniformity, we suggest plasma anode to be formed with the help of combined discharge matching high-current Penning discharge and vacuum sparks (arcs). At that, spark plasma sources are placed directly in the ring anode of Penning discharge and are powered from the same pulsed circuit as Penning discharge. Such a scheme of plasma anode formation provides two important advantages:

- a) anode plasma density in peripheral region of the column increases, and as a result, the beam uniformity improves;
- b) spark sources give some additional portion of plasma in near-cathode space that improves stability of beam parameters, particularly at low pressures of working gas.

The paper presents results of investigations of plasma anode based on combined discharge and results of testing of electron gun with such plasma anode.

MODELING OF THECA STARK EFFECT OF THE Kr⁺ ION

E. V. Koryukina, V. I. Koryukin¹

*National Research Tomsk state university, Tomsk, Russia,
evk@phys.tsu.ru*

¹ *Siberian state medical university, Tomsk, Russia, vik180248@mail.ru*

In a study of plasma by spectroscopic methods, both atomic and ionic emission spectra of an active medium are registered in experiments. The behavior of spectra induced by an alternating electric field is characterized by shifts and splitting of spectral lines in this field and strongly depends on frequency and strength of the electric field. In order to interpret the experimental data accurately, and for understanding the processes taking place in plasma, one needs a correct theoretical method for calculating these spectra. In this work, a reliable method of diagonalization of the energy matrix of an ion in the electric field is used to simulate the AC Stark effect of a Kr ion in a

circularly polarized electric field. Earlier this approach was applied to calculating emission spectra of NeII and ArII ions, and the obtained results have allowed us to reveal a number of interesting regularities in the AC Stark effect for these ions. Rare gases are often used in plasma physics, so they were chosen as subjects for study.

In this work, a theoretical study of the AC Stark effect of the KrII ion was performed for the electric field parameters changing in a wide range, a namely: the electric field strength changes up to 10kV/cm, and the electric field frequency changes from 10^2 to 10^4 MHz. In the framework of the suggested theoretical method, the following dependences in the behavior of the AC Stark effect of a Kr ion were investigated: i) the dependence of the Stark effect on the electric field strength, ii) the dependence of the Stark effect on the electric field frequency, iii) the dependence of the energy shift directions on the electric field strength and frequency. Moreover, the calculation results have shown that shifts and splitting of the Kr^+ energy levels strongly depend on the electronic structure of the energy level under consideration.

The results obtained are of interest both from a theoretical point of view and for practical applications of the developed theoretical approach. The simulation data allow us to reveal regularities inherent in the behavior of shifts and splitting of spectral lines of a Kr ion in the electric fields of an arbitrary frequency and strength. The results of modeling the emission spectra can also be used for plasma diagnostics and for solution of problems in plasma spectroscopy.

**THERMOCHEMICAL SELF-HEATED HOLLOW CATHODE
FROM A TITANIUM NITRIDE**

A. I. Menshakov, N. V. Gavrilov

*Institute of Electrophysics, Ural Division of the Russian Academy of
Sciences, Ekaterinburg, 620016, Russia*

*Phone: (343)2678778, Fax: (343)2678794, E-mail:
gavrilov@iep.uran.ru*

Findings of investigation of the discharge with self-heated tubular hollow titanium cathode operating with discharge currents in the range 4 - 20 A are presented. Working gas (argon, nitrogen) flow through a hollow cathode 8 mm in diameter was 40 sccm, while gas pressure in an anode part of the discharge varied within the range 0,1 - 3 Pa by changing of pump speed. It was shown, that features of high-current operation of the cathode in a self-heated mode in the nitrogen flow are caused by formation of a high-temperature phase of titanium nitride on the active zone surface of the cathode. Optimum modes of training of the cathode by the discharge operation in nitrogen and the time necessary for transition of the cathode in high-current operating mode were determined. Behaviour of the cathode in different gas media was investigated and rates of erosion of the thermochemical cathode during long-term operation in nitrogen and argon were measured.

**REPRATE ION BEAM ACCELERATOR WITH INTERMEDIATE
LINEAR STEP-UP TRANSFORMER**

A.V.Petrov, P.S. Anan'in, *V. Bystritskii,J. Yampolsky, *I.F. Isakov,
V.B. Karpov, *V.M. Matvienko, N.M. Polkovnikova ,A.A. Sinebryukhov,
Yu.P. Surikov, Yu.P. Usov, **K. Walters**

*Institute of Physics and Technology of Tomsk Polytechnic
University, Tomsk, 634050, Russia*

**University of California at Irvine, Irvine, CA, 92617*

***TriAlpha Energy, Inc., Foothill Ranch, CA, 92610*

The accelerator intended for generation of powerful proton beams has been developed, made and tested. The accelerator parameters: the range of working voltages is 140-280 kV, pulse duration is 600 ns, impedance is 12,5 Ohm, frequency is 25 Hz. The accelerating complex includes: generator of accelerating voltage pulses on the basis of a linear transformer with forming lines, diode section with the magnetic-isolated ion diode with a radial B-field and emissive plasma source based on induction breakdown of a pulsed gas puffing, complex of supply sources of the ion diode and generator and the control and synchronization unit of the accelerator

**LOW-IMPEDANCE ROD-PINCH DIODES AS INTENSE
X-RAY SOURCES**

S.A. Sorokin

*Institute of High Current Electronics SB RAS, Tomsk, Russia,
s.sorokin@rambler.ru*

An experimental study of a point-like radiographic x-ray source based on plasma-filled rod-pinch (PFRP) diodes and low-impedance high-current generators is presented. A PFRP diode operates at considerably lower impedance than the vacuum rod-pinch (RP) diode, allowing higher currents and, hence, higher x-ray doses to be produced. Due to the low impedance of the PFRP diodes the high current generators developed earlier for Z-pinch experiments can be used as drivers for these diodes.

Experiments were performed on the MIG generator (1 MV, 1.5 MA, 80 ns) at the Institute of High Current Electronics, SB, RAS. As the water-insulated pulse-forming lines of the MIG generator are charged negatively and the anode rod tip is facing toward the generator transmission line, the x-ray radiation is extracted in the radial direction. The anode rod shapes have been found in the experiments for which a point-like x-ray source appropriate for off-axis radiography is produced. It has been shown that bending the anode rod has an insignificant effect on the physical processes responsible for the formation of an electron diode near the anode tip. In the experiment, plasma was also injected into the anode–cathode gap upstream of the plasma-filled rod-pinch diode to increase the duration of the initial short-circuit phase and to provide voltage gain and pulse sharpening. The electron beam formed in the PFRP diode and the x-ray source had the following parameters: The electron energy was 1–1.8 MeV, the diode current 0.4–1.0 MA, the x-ray dose at 1 m from the source was 2–4 rad (tungsten rod anode, LiF thermoluminescent dosimeter behind a 5-mm-thick aluminum screen), the x-ray pulse duration ranged from 10 to 30 ns and the spot size from 0.5 to 1.1 mm.

Preliminary experiments were performed with a radial thin foil instead of a plasma injection. The $J \times B$ forces push the foil to the rod tip. The foil thickness and the length of the rod extension beyond the radial foil are chosen so that the foil plasma moves past the end of the rod at the peak of current. Several successive intense bremsstrahlung pulses are formed as the result of current reconnection in the foil and rod plasmas.

ION B_r – DIODE WITH THE ACTIVE ANODE

A. V. Stepanov, V. S. Lopatin¹, G. E. Remnev

*National Research TPU, Institute of High Technology Physics, Tomsk,
Russia, StepanovAV@mail.ru*

¹Lipetsk, Russia, lopus@qip.ru

The efficiency of pulsed ion accelerator and ion beam parameters are generally determined by the plasma formation method in the diode, plasma density and homogeneity. Preliminary plasma generation on the cathode surface and using of microsecond duration pulses of accelerating voltage allow to increase the diode work efficiency.

This work is devoted to the investigation of the ion current parameters of the B_r – diode in the mode of the preliminary plasma generation on the anode, obtained due to the additional voltage pulse.

The first negative voltage pulse provides the plasma formation on the anode surface and first of all plasma's composition is determined by the material of a covering. During this impulse of voltage the value of diode impedance is keeping high. By the time of the accelerating voltage formation the anode - cathode area completely fills by plasma.

Pause duration between voltage impulses changes in a range from 350 to 650 nanoseconds. At the same time the value of ion current density in the focus of the diode is equal to 720 A/cm^2 and in a number of experiments increases to 850 A/cm^2 . Energy density of the ion beam in the diode focus is shown not to exceed the value of $5,5 \text{ J/cm}^2$.

The behavior of the diode impedance is characteristic for operation of the diode filled the plasma. During the initial time the diode is working in a mode of short circuit. Then at the front of a total current impulse the impedance growth with a speed of $0,6 \text{ Ohm/ns}$ and the current growth rate $5,8 \cdot 10^{12} \text{ A/s}$ are revealed. In the sequel the recession of an impedance of the diode with a speed approximately $0,01 \text{ Ohm/ns}$ is found to observe. Actually ion diode works in a mode of a plasma-erosion breaker.

COMPACT NANOSECOND ELECTRON BEAM SOURCE BASED ON 200 KV SOS GENERATOR

V.V. Uvarin, D.L. Kuznetsov, S.K. Lyubutin, B.G. Slovikovskii

Institute of Electrophysics, Ekaterinburg, Russia, uvv@iep.uran.ru

The compact device for generation of pulsed electron beam is described. As power supply, we use generator of high-voltage pulses SM-4N. Distinctive feature of mentioned generator is completely solid-state switching system for high-voltage circuits of inductive storage, based on semiconductor opening switches (SOS-diodes). Application of solid-state breakers secures considerable operational lifetime, high stability of output pulses and small size of the device.

For production of electron beam cylindrical vacuum tube (electron gun) with explosive-emission cathode was connected to HV generator. During the work of the e-beam source the vacuum tube is pumped out by the fore pump

(pressure in the vacuum tube - 10^{-2} Torr). The accelerated electrons leave the gun through the replaceable Ti foil with a thickness of 8 μm .

Technical features of the present device: electron energy – 200 keV, electron beam current – 200 A, the cross-section diameter of exit beam - 1.5 cm, electron beam current density $\sim 10^2$ A/cm²; pulse duration – 5 ns, maximal repetition rate – 100 Hz; overall dimensions (without the vacuum pump) - 21x23x110 cm³. Resource with continuous operation is determined by the destruction of output foil and exceeds 10^5 pulses for the frequency of 10 Hz. If necessary the replacement of output foil is carried out easily during several minutes.

Present compact pulsed electron beam source is intended for the investigations in the high energy chemistry, radiation biology and emission spectroscopy.

INVESTIGATION OF TRANSFER HIGH-CURRENT ELECTRON BEAM IN PLASMA CHANNEL

E.S. Vagin, V.P. Grigoriev, V.V. Ofitserov

Tomsk Polytechnic University, Tomsk, Russia, VaginEvS@yandex.ru

The paper examines the transfer of electron beam into a chamber with low-pressure plasma in magnetic field. The research is based on the self-consistent mathematical model that takes into account current and charge neutralization of electron beam and change in its parameters during the transfer. A numerical study was conducted using particle in cell (PIC) method. The calculations used beam and plasma parameters that were similar to the ones used in experiments with transferring high-current beams in plasma-filled systems.

Based on the calculations, the patterns of beam charge and current neutralization depending on system parameters and external magnetic field were determined. Analytical examination was carried out to investigate transverse beam instability in plasma channel at the nonlinear phase.

THE ION-BEAM INSTALLATION FOR FINISH TREATMENT OF DISPERSION FUEL CLADDINGS

N.V.Volkov¹, B.A.Kalin¹, V.P.Krivobokov²

¹*National Research Nuclear University MEPhI, Moscow, Russia,
e-mail: nvvolkov@mail.ru*

²*National Research Tomsk Polytechnic University, Tomsk, Russia*

Ion-beam cleaning and polishing the outer surface of fuel claddings is one of the most effective methods of increasing life of fuel elements. As a result of this treatment decreases the surface roughness is decreased and technological defects of the outer surface are “healed”. The method of ion-beam treatment can also be easily transformed for additional ion-alloying of the fuel cladding surface layer in the mode of ion-mixing of pre-deposited atoms on the fuel cladding surface, as well as for the controlled oxidation of the surface during ion-beam polishing.

The installation KVK-10 for treatment the outer surface of shortened fuel elements (500 mm) has been developed and produced. This installation allows for simultaneous processing of up to six rods in an upright position. The work chamber is equipped with three magnetrons and two ion sources that provide cleaning and deposition of metal films on the outer surface of the fuel cladding along its entire length. To reduce the risk of uncontrolled oxidation of the cladding surface during ion-beam treatment there is used the oil-free high vacuum system (turbomolecular high vacuum pump and low vacuum spiral pump) with automatic system of maintaining the desired pressure in the chamber.

As shown by the results of studying the state of the treated cladding samples, after ion polishing and joint treatment (ion cleaning + ion polishing) the surface roughness is significantly reduced from $R_a = 1.5-2 \mu\text{m}$ to $R_a = 0.5 \pm 0.2 \mu\text{m}$. Homogeneous structure-phase states have been made on the outer surface of the fuel claddings, made from alloy E110 under the following conditions: ion beam irradiation of Ar^+ ; average ion energy of 0.5-1.5 keV; total ion current from 0.3 to 0.6 A; accelerating voltage 1 to 2 kV; radiation dose $(5 - 10) \times 10^{18} \text{ ion/cm}^2$. The adjustment of a joint work of the three ion sources has been carried out. Working positions of samples in the vacuum chamber, which are specified under the special program, have been determined.

The parameters of the high vacuum system have been specified, and operating parameters of the installation (pressure of working and residual gases in discharge chamber; ion current density and ion energy; temperature of the

installation elements) have been adjusted to ensure maximum speed of treatment of fuel claddings. The optimal parameters of the fuel claddings treatment have been determined, and its thinning rate has been calculated for different treatment modes.

**CHARGE NEUTRALIZATION AND RISE-UP PORTION
EROSION OF LOW-ENERGY ELECTRON BEAM WHEN
INJECTING INTO NEUTRAL GAS**

I.L. Zvigintsev, V.P. Grigoriev

TPU, Sovetskaya 84/3, Tomsk, 634034, Russia, 8b20@sibmail.com

During the transportation of low-energy electron beams in a gas it is a significant question about the time of charge neutralization. In contrast to relativistic beams the dominating factor is not the beam spreading under radial field of space charge in the absence of an external magnetic field, but a formation of virtual cathode. In this work it is considered a case of beam injection into neutral gas without external magnetic field prior to obtaining a full charge neutralization. Ionization processes are investigated in conditions of virtual cathode formation which blocks beam passage, and beam spreading under coulomb forces. A model is developed, which enables to get values of plasma density by the moment of full charge neutralization depending on the type and pressure of gas, beam current and duration of beam current rise-up portion. The time intervals of virtual cathode collapse with different beam parameters and gas pressures are obtained. The system parameters are determined when the virtual cathode doesn't form.

THE WIRE EXPLOSION STAGE DURING X-PINCH SOFT X-RAY SOURCE FORMATION

**A.P. Artyomov, S.A. Chaikovsky, A.V. Fedunin, V.I. Oreshkin,
S.V. Shljakhtun, I.V. Lavrinovich**

*Institute of High Current Electronics SB RAS, 2/3, Akademichesky ave.,
Tomsk, 634033, Russia*

Phone: 8(382-2) 492-133, e-mail: aap545@gmail.com

In X-pinch experiments, two or more metal wires 10–50 μm in diameter crossed like the letter “X” are used through which current pulse is passed. When the current rising rate exceeds 1 kA/ns in the wire crossing region a plasma hot spot several micrometers in size forms which radiates soft x-rays within 1 ns pulse. Hot spots of this type are currently one of the brightest laboratory sources radiating in the soft x-ray range. The parameters of this type of x-ray sources make them attractive for projection radiography of various short-lived physical objects.

The X-pinch hot spot formation has few stages – the wire explosion, the wire material implosion in the near crossing region, the wire material ejecting from the crossing point, the neck development leading to high density and temperature plasma formation. The first stage runs at the enough high current rising rate (higher 0.25 kA/ns) which is higher than the typical rising rate for the wire explosion investigation experiments.

In order to understand better the wire explosion process in a X-pinch experiments have been performed with low scale pulsed generator. The generator has a diameter of 330 mm and a height of 480 mm. The generator consists of cylindrical self-made capacitor with multi-gap multi-channel switch and delivers up to 150 kA with rising time of 130 ns into the X-pinch load. X-pinch was made of four tungsten wires with diameter of 13 micron. The X-pinch current and voltage were measured by Rogovsky coil and capacitive divider, respectively. Such diagnostics allows one to measure the power and energy deposition to wire, the action integral for the wire and estimate the X-pinch initial resistivity and inductance. Also energy deposition into x-pinch plasma hot spot could be measured. In the report the experimental results obtained and their discussion will be presented.

EFFICIENCY OF THE ENERGY DELIVERY FROM VACUUM MITL OF THE GIT-12 GENERATOR TO THE WIRE ARRAY PLACED IN THE WATER

S.A. Chaikovsky, V.A. Kokshenev, A.Yu. Labetsky, A.V. Shishlov

*Institute of High Current Electronics SB RAS, 2/3, Akademichesky ave.,
Tomsk, 634033, Russia*

Phone: 8(382-2) 492-133, e-mail: aap545@gmail.com

The generation of strong shock waves is one of the important points in research concerned to physics of high density non-ideal plasma. One of the possible ways for strong shock wave production is electrical explosion in water. Using cylindrical wire array and a pulsed power generator it is possible to generate converging shocks. Such approach was successfully tested at the current level of 550 kA with rising time of 350 ns. As the result the generation of an extreme state of water with pressure up to 4 Mbar in the vicinity of the array axis due to converging strong shock wave was reported [1].

The main purpose of this work was realization of the abovementioned method for conditions of GIT-12 generator with significantly higher level of the current. According to estimates and MHD simulations for GIT-12 generator with stored energy of 2 MJ approximately 100-200 kJ could be transferred to the shock wave energy. At the array length of 10 cm the energy per cm is order of 10-20 kJ. With a deuterium plasma placed at the axis the pressures higher then 10 Mbar could be reached at the plasma temperature of few hundreds eV.

The GIT-12 generator consists of twelve Marx's connected in parallel via vacuum transmission lines. So, the idea was to place a dielectric water vessel with a wire array inside of it into the vacuum load region of the GIT-12 generator. Preliminary experiments have shown that energy delivery to the wire array is rather poor due to surface breakdown of the vacuum-insulator interface. A number of the load blocks was developed, fabricated and tested. In the regime with total inductance a low electrical breakdown voltage of the insulator was found. This voltage level does not correspond to technical data on the insulation. In the regime with lowered inductance the efficient energy input to electrically exploded load was achieved. It was found that even lowered energy input leads to cumulative jet formation which causes significant damage of the on-axis plastic flanges with thickness of 5 mm. Thus, in course of the experiments some features of the load behavior was understood from

point of view mechanical and electrical strength. Analysis of the results will be present in the report.

1. A. Fedotov-Gefen, S. Efimov, L. Gilburd, G. Bazalitski, V. Tz. Gurovich, and Ya. E. Krasik, *Physics of Plasmas*, 18, 062701 (2011).

A LOAD CURRENT MULTIPLIER FOR THE TERAWATT-LEVEL MIG GENERATOR

**I. M. Datsko¹, S. A. Chaikovsky¹, N. A. Labetskaya¹,
V. I. Oreshkin¹ A. S. Chuvatin²**

¹ *Institute of High Current Electronics SB RAS, Tomsk, Russia,
datsko@ovpe.hcei.tsc.ru*

² *Ecole Polytechnique, Palaiseau, France*

Powerful pulsed current generators of a megaampere range are widely used in studies of plasma properties. One of the most important parameters of a generator used in such researches is a load current amplitude.

It is natural for scientists to seek after a technical solution that provides an increase in the load current amplitude without a total modernization of a generator. Such opportunity is given by implementation of a load current multiplier (LCM) that allows increasing of the current amplitude in the regime of a constant low-inductance load.

The principle of operation of a load current multiplier is similar to that of a transmission-line wave transformer. In a regime of the current doubling, a design of the load current multiplier is represented by two coaxial vacuum lines connected in series from the generator side and in parallel from the load side.

The MIG generator is a terawatt-level pulsed power generator that provides a load current amplitude up to 2.5 MA with a current rise time of 100 ns. For several years, the MIG generator is used to study interaction of fast megagauss magnetic fields with metals. A distinguishing feature of conducting experiments is that the inductance of a load, which is metal cylinders with a diameter from 1 to 4 mm, is almost constant during the current pulse rise. When the LCM is used, this would make it possible to avoid a drop in the transformation ratio during the power feed stage, which is caused by an increase in the load impedance.

A design of the load current multiplier has been developed, and its operation with a current transformation ratio of 1.75 has been demonstrated on the low-impedance MIG generator at the terawatt power level. The practicality of using the load current multiplier operating with a constant low-inductance load, for example in the studies of skin electrical explosion of wires and non-linear diffusion of megagauss magnetic fields, has been shown. The use of the LCM provides an 1.5-fold increase in the load current in comparison with the regular operation regime of the MIG generator. The load current multiplier has a relatively simple design, and it can be easily installed and disassembled permitting the use of the MIG generator in other operation regimes with the loads of different impedance.

FIRST RESULTS OF TUNGSTEN Z-PINCH WIRE-ARRAY LOADS ON THE MICRO-SECOND SPHINX GENERATOR

**T. d'Almeida, P. Maury, J. Grunenwald, F. Zucchini,
D. Plouhinec, F. Lassalle, A. Loyen, A. Morell**

CEA, DAM, GRAMAT, F-46500 Gramat, France

SPHINX machine is a LTD Pulsed Power driver (6MA, 800ns) developed at CEA/Gramat to implode Z-pinch wire-arrays and gas-puff loads and produce k-shell radiation for radiation effects experiments.

Since 2005, successful efforts have been done to design efficient Aluminum wire-array and Argon gas-puff loads adapted to the micro-second rise time of the machine [1]. In order to increase total power output and total radiation yield, a new compact wire-array load ($h = 5$ cm, $\phi = 8$ cm) based on a high Z material, such as Tungsten, has been developed. These loads increase by a factor of two (compared to Aluminum loads) both power and total yield produced below 1 keV. Total power appears to be close to 15 TW and total yield ~ 500 kJ (25 % of electrical energy stored).

In this paper we develop the initial numerical simulations using the MHD-3D Gorgon code, that have been done to design the optimized load in terms of radius, height, number of wires and inter-wire-gap for the long pulse. Experimental results are also shown using appropriate diagnostics for the sub-keV spectral range (two color time-resolved pinhole, ...)

1 H. Calamy et al., Phys. Plasmas, 15, 012701 (2008).

**EXPERIMENTAL STUDY OF SURFACE STABILITY OF
CYLINDRICAL CONDUCTORS IN THE FAST RISING
MEGAGAUSS MAGNETIC FIELD**

**N. A. Labetskaya, V. I. Oreshkin, S. A. Chaikovsky, I. M. Datsko,
N. A. Ratakhin, Y.A. Sukovatitsyn, E.N. Volkov**

Institute of High Current Electronics SB RAS, Tomsk, Russia, natalia@ovpe2.hcei.tsc.ru

In the magnetic fields with an induction higher than one megagauss, mechanical and thermal limits for all known materials are exceeded. The magnetic fields of a megagauss range can be obtained only with the help of pulsed facilities. The main processes during interaction of the megagauss pulsed magnetic fields with metals are non-linear diffusion of the magnetic field and formation of dense low-temperature plasma on the conductor surface. If the magnetic field rise rate is greater than the magnetic field diffusion velocity, then formation of the plasma on the conductor surface is determined by the electrical explosion of the skin layer. The magnetic diffusion becomes significantly non-linear at the typical values of the magnetic induction of 300÷500 kG. The interest of scientists to these processes is determined by their influence on the energy transport efficiency in the magnetically insulated vacuum transmission lines of the multi-terawatt pulsed generators with a current level of 30÷50 MA and a current rise time of 100 ns, which are developed at present. Such generators are planned to use for implementation of thermonuclear fusion using Z-pinch schemes.

Experimental studies of non-linear diffusion of the magnetic field to a conductor and also its influence on the conductor surface explosion and the following development of instabilities on the plasma surface have been carried out on the high-current MIG generator (a peak current of 2.5 MA, a current rise time of 100 ns). Aluminum and titanium tubes with different diameters were used as a load. The wall thickness of the tubes were varied in the experiments. The instant of non-linear magnetic diffusion wave arrival at the inner surface of the conductor was registered by a voltage divider located inside the tube. Self-radiation of the outer tube surface was recorded by the optical four-frame camera HSFC-Pro with a frame exposition of 3 ns. The instant of conductor surface explosion and dynamics of XUV radiation of surface plasma were registered by an open vacuum x-ray diode with aluminum cathode. The experimental results are presented and discussed in the paper.

DETERMINATION OF THE CURRENT DISTRIBUTION IN A PLANE SHEATH USING B-DOT PROBES

A. Yu. Labetsky, V. A. Kokshenev, A. V. Shishlov

*Institute of High Current Electronics SB RAS, 2/3 Akademicheskoy ave.,
Tomsk, 634055, Russia
phone: +7 (3822)-492133, fax: +7 (3822)-491677, e-mail:
aly@ovpe2.hcei.tsc.ru*

A technique of reconstruction of the current distribution profile in a plane current sheath using measurements of the magnetic flux by a number of B-dot probes is proposed. Analytical expressions relating the distribution of the load current with a detector response have been obtained in the quasi-steady approximation. The calculated results are compared with the data of the experiments performed on the GIT-12 generator with the quasi-static test loads.

SOME PRINCIPAL ISSUES OF PLASMA OPENING SWITCHES OPERATION

S. V. Loginov

*Institute of High Current Electronics, Tomsk, Russia,
loginov@oit.hcei.tsc.ru*

The report considers the erosion mechanism of operation of nano- and microsecond plasma opening switches (POSSs). For this purpose, postulates of the well-known erosion model of the POS operation are reviewed and some remarks on its individual statements are discussed. A voltage scaling for a nanosecond switch with rarefied plasma ($\sim 10^{13} \text{ cm}^{-3}$) is derived. It is shown that the peak voltage across the nanosecond switch on its opening is proportional to the switch conduction current. The formation of an erosion gap in a microsecond switch with high-density plasma ($\sim 10^{15} \text{ cm}^{-3}$) is put to phenomenological analysis and a voltage scaling for the switch is obtained. It is found that in the microsecond switch, unlike the nanosecond switch, the peak voltage is inversely proportional to the switch conduction current.

EFFICIENCY OF MICROSECOND PLASMA OPENING SWITCHES

S. V. Loginov

*Institute of High Current Electronics, Tomsk, Russia,
loginov@oit.hcei.tsc.ru*

The report discusses the efficiency of energy transfer from an inductive energy store to a short-circuit load with a microsecond megaampere plasma opening switch. A very simple electrotechnical technique for estimation of electron current loss is proposed and its operability is proven. The applicability of the technique for analysis of experimental data is considered. The low rate of rise of the POS resistance along with considerable current loss causes weak pulse sharpening with a time shift of the current pulse and a decrease in its magnitude. The above facts complicate practical realization of the pulse compression technology of interest.

FEATURES OF THE PLASMA-CHANNEL FORMATION DURING THE VOLTAGE GENERATOR WITH THE 1-MV/NS-VOLTAGE-RISE-RATE DISCHARGE TO THE VACUUM COAXIAL LINE CONTAINING MICROCONDUCTOR ENCLOSED GAP

K.A. Nagayev, S.V. Barakhvostov, M.B. Bochkarev, N.B. Volkov

*Institute of Electrophysics UB RAS, Russia, Yekaterinburg,
kanagayev@iep.uran.ru*

In our experiments the generator “RADAN-220” was discharged to the 15 cm long and 10 cm internal diameter coaxial line. The gap in the central conductor was enclosed via 5–15 mm long micron diameter wires of Cu, Ni and W. The voltage amplitude – $U_0=220$ kV, stored energy – $w=1$ J; pulse rise duration – 200–500 ps.

It has been established that during the propagation of the voltage pulse, with the rise time < 1 ns, within the line containing the microconductor enclosed gap the discharge channel formation results from the electrodynamic processes, arising within the microconductor’s surface layer and its vicinity. The existence of the pressures range ($0.7 < P < 3.4$ Torr for Cu microwires with

$d=20\ \mu\text{m}$) where microconductors either do not destruct or are destructed via thermo-mechanical strains is revealed. At that in the wire abrupture the arc was lit. Using the electron microscope we established that craters of less than $0.3\ \mu\text{m}$ in diameter are spread regularly over the wire cathode end; also matter electrotransport and micro-droplets of about $0.5\ \mu\text{m}$ size were observed on the acquired SEM-images.

At $P<0.7$ Torr the discharge channel originates from the microconductors skin layer “electrodynamical explosion”. The discharge channel contains plasma corona, dense core and a transitional layer in between. It is shown that the emission spectrum at the moment of plasma corona formation is continuous. Using the Cu spectral lines (510.554, 515.324, 521.82) nm intensities ratio the electron temperature evaluation was acquired to be: $T_e=0.7\ \text{eV}$.

The work is carried out under partial financial support of the RFBR (project No. 10-08-00691-a), the Presidium of UB RAS within the program for basic research of the Presidium of RAS «Matter at high energy densities» (project No. 12-П-2-1005) and junior scientists and postgraduate students research support (project No. 11-2-III-590).

STABILITY OF NONLINEAR MAGNETIC FIELD DIFFUSION

V.I.Oreshkin, S.A.Chaykovsky, N.A.Labetskay, I.M.Datsko

High Current Electronic Institute SB RAS, Tomsk

The growth of large-scale instabilities at the electric explosion of conductors in the skinning current mode studied on the high current generator MIG (amplitude of a current of up to 2.5 MA current, rise time of 100 NS). Experiments have shown that large-scale instability with the wave length of 0.02-0.05 cm appear directly after the release of the axis of the waves of the nonlinear diffusion of a magnetic field. Analysis of the development of instabilities was held in the framework of the linear approximation. It was shown that the instability of the wavelength of the order of the conductor thickness were suppressed during the propagation of f nonlinear diffusion wave of a magnetic field. Comparisons were made of the experimental results with the results of numerical simulation.

ENERGY DENSITY INCREASING IN CHANNEL OF SUPER-HIGH PRESSURE MEGAAMPERE DISCHARGE DUE TO RESONANCE OF DIFFERENT TYPE OSCILLATIONS OF THE CHANNEL

**M.E. Pinchuk^{1,2}, A.A. Bogomaz¹, A.V. Budin¹, Ph.G. Rutberg¹,
A.G. Leks¹, V.Yu. Svetova^{1,2}, S.Yu. Losev¹, A.A. Pozubekov¹**

¹*Institute for Electrophysics and Electric Power of Russian Academy of Sciences (IEE RAS), St.Petersburg, Russian Federation, pinchme@mail.ru*

²*St.Petersburg State Polytechnical University (SpbSPU), St.Petersburg, Russian Federation, pinchme@mail.ru*

Discharges in hydrogen, ignited by wire explosion, with current amplitude up to 1.6 MA and initial gas pressure up to 160 MPa were investigated. The analysis of soft X-ray intensity oscillations in the discharges with the initial hydrogen pressures of 5 - 7 MPa has showed that it could be caused by periodic changes in the diameter of the discharge channel. The same period oscillations were observed on voltage and current curves and on the photostreaks in optic range at initial hydrogen pressures of 5 - 35 MPa. It was established that the oscillation period is proportional to the square root of the atomic number of the initiating wire material. This fact is an argument that the diameter variations of the discharge channel with the metal vapors are associated with aligned magnetic and gaskinetic pressure.

In go over to the initial pressure of 80 - 160 MPa, which are created by adiabatic compression, there are the amplitude of acoustic pressure on the discharge chamber wall increasing and the growth of voltage fluctuations in the discharge simultaneous with it. The amplitude of pressure fluctuations at the wall reaches 150 MPa and voltage jump is of ~3 kV. This oscillations are several times more then at an initial pressure of 5 -35 MPa.

In some experiments it was observed abrupt increase in the oscillation amplitude, which were caused by the resonance of the acoustic oscillations and the oscillations connected with alignment of the gas-kinetic pressure and the magnetic pressure, as far as frequencies of these oscillations are close to each other in accordance with the estimates and the experimental data. Thus, appropriate initial conditions in the experiment allows to increase the energy density in the discharge channel.

**CURRENT PASSAGE MECHANISM IN A HIGH-CURRENT
LOW-PRESSURE PULSED GLOW DISCHARGE****I. A. Shemyakin, Yu. D. Korolev, N. V. Landl, O. B. Frants***Institute of High Current Electronics, Tomsk, Akademichesky Ave, 2/3,
Russian Federation, shemyakin@lnp.hcei.tsc.ru*

Currently, high-current low-pressure pulsed glow discharge (pseudospark discharge) is well studied in the experimental aspect. In contrast, in theoretical terms only the discharge formation process is described in detail. Present paper describes current passage mechanism at high-current discharge stages – dense and superdense glow. The model, which allows estimate the parameters of the discharge plasma and the magnitude of the voltage drops at different discharge areas is presented. It is shown that there is a double electric layer between the hollow cathode plasma and plasma in the main gap. Discharge current at the anode is provided mainly by the thermal electrons from plasma in the main gap, which are capable to overcome the potential barrier near the anode. At the stage of dense glow discharge the main fraction of discharge current at the cathode is carried by an ion component. At the stage of superdense glow an electron component can exceed an ion one. It is shown that presented model is in good agreement with experimental results.

DEUTERIUM GAS-PUFF DYNAMICS AND NEUTRON PRODUCTION IN EXPERIMENTS ON THE GIT-12 GENERATOR**A. V. Shishlov¹, F. I. Fursov¹, B. M. Kovalchuk¹, V. A. Kokshenev¹,
N. E. Kurmaev¹, A. Yu. Labetsky¹, N. A. Ratakhin¹, D. Klir²,
J. Cikhardt², J. Kravarik², P. Kubes², K. Rezac²**¹ *Institute of High Current Electronics SB RAS, Tomsk, Russia, e-mail:
ash@ovpe2.hcei.tsc.ru*² *Czech Technical University in Prague, Prague, Czech Republic, e-mail:
klirdani@fel.cvut.cz*

The paper presents results of experiments with deuterium gas puffs carried out on the GIT-12 generator (Tomsk, Russia). The main attention was

paid to investigation of implosion dynamics and neutron emission of deuterium Z-pinches. A double shell gas puff with the inner-to-outer shell mass ratio close to unity was used as a load. The total gas puff mass was varied in the range from 50 to 85 $\mu\text{g}/\text{cm}$. The experiments were carried out at two generator operation mode, with and without a plasma opening switch (POS). In the first mode, the peak implosion current reached 2.7 MA, and the implosion time was between 280 and 470 ns depending on the initial gas puff parameters. In the experiments without the POS, the peak implosion current approached only 2 MA, but the implosion time increased to 670÷720 ns. The following set of diagnostics was used: a streak camera, pinhole cameras, x-ray vacuum diodes, and photoconducting detectors. The neutron diagnostics included time-of flight diagnostics based on four scintillation detectors, an activation detector, and bubble detectors.

The experiments showed that the implosion dynamics of deuterium gas puffs was characterized by two features: first, the implosion started from a radius that was significantly larger than the nozzle radius; second, current division between the inner and outer shells was observed, and acceleration of the shells to the axis occurred simultaneously. The use of available preionization system did not allow suppression of the current division. This phenomenon has a negative impact when the gas puffs are used for K-shell radiation production. Its influence on the neutron emission will be studied in more details in our future experiments.

The maximum neutron yield registered in the experiments was 2×10^{11} . Summarizing of the available experimental data on the neutron yield from deuterium gas puffs gives the dependence of the neutron yield on a peak implosion current as $Y_N \propto I^3$.

K-SHELL X-RAY AND NEUTRON EMISSION FROM A DOUBLE SHELL GAS-PUFF LINER

S.A. Sorokin

*Institute of High Current Electronics SB RAS, Tomsk, Russia,
s.sorokin@rambler.ru*

Experiments on the neon, argon and deuterium double shell gas-puff liner implosions have been performed on the MIG pulse generator (2 MA, 80 ns). In the experiments the influence of the current return configuration (straight current return made of rods in the form of squirrel cage, and helical current return in which the every rod is a helix) on the liner stability and radi-

al compression ratio (homogeneity and diameter of the pinched plasma) as well as the argon (3-5 keV) and neon (0.9-1.5 keV) K-shell radiation and neutron parameters was investigated. It is shown that using a helical current return jointly with a double shell liner structure homogeneous (without typical hot points) neon and argon pinches of diameter 0.2-0.3 mm can be generated (radial compression ratio ~ 100). The K-shell yields of 0.8-1.0 kJ for argon and 4-5 kJ for neon were achieved. The neutron yields of $(1-3) \times 10^{10}$ with a straight current return and $(2-5) \times 10^9$ with a helical current return were measured in deuterium liner implosions. To our knowledge, this is the first experimental evidence that neutrons are produced (by beam-target mechanism) mainly in constrictions formed as a result of $m = 0$ instability developing.

HEATING OF HIGH-DENSITY HYDROGEN BY HIGH-CURRENT ARC RADIATION

**V.Yu. Svetova, Ph.G. Rutberg¹, M.E. Pinchuk^{1,2}, A.A. Bogomaz¹,
A.V. Budin¹, A.G. Leks¹, S.Yu. Losev¹, A.A. Pozubekov¹**

Institute for Electrophysics and Electric Power of Russian Academy of Sciences, Saint Petersburg State Polytechnic University, St.-Petersburg, Russian Federation, gre_inf@mail.ru

¹ *Institute for Electrophysics and Electric Power of Russian Academy of Sciences, St.-Petersburg, Russian Federation*

² *Saint Petersburg State Polytechnic University, St.-Petersburg, Russian Federation*

The investigation results of high-density hydrogen heating by high-current electric arc are presented at initial pressure from 5 MPa to 300 MPa with current amplitude up to 1.6 MA and current rate of rise 10^9 - 10^{11} A/s. When changing the initial pressure and current rate of rise, channel temperature varies from several electronvolts to hundreds electronvolts. Arc channel radius is several millimeters. But the radius of the discharge chamber is greater than the radius of the arc channel on approximately order of magnitude. High efficiency of gas heating is caused by radiation absorption of hydrogen surrounding the arc. Current channel consist of vapor of the initiating wire. At current rate of rise of 10^9 A/s and relatively small current amplitude the gas heating occurs due to radiation absorption in the band transparency of hydrogen by the wire vapours with photon energies less than 13.6 eV. At current rate of rise of 10^{11} A/s gas heating is due to hydrogen absorption of soft X-rays from discharge channel.

**DIFFERENT SCENARIOS OF FORMATION OF THE
CORONA-CORE STRUCTURE DURING ALUMINUM WIRE
EXPLOSION**

**Tkachenko S. I.^{1,2}, Zhakhovsky V. V.^{2,3},
Shelkovenko T. A.⁴, Pikuz S. A.⁴**

¹*Moscow Institute of Physics and Technology, Dolgoprudny, Moscow Region,
Russia,*

²*Joint Institute for High Temperatures, RAS, Moscow, Russia,
svt@ihed.ras.ru,*

³*University of South Florida, Tampa, FL, USA,*

⁴*Lebedev Physical Institute RAS, Moscow, Russia*

According to numerical calculation of an aluminum wire explosion it was obtained that, the core material remains for a long time in the state of dense nonideal plasma with a temperature of 1–3 eV. The core goes into a two-phase liquid-vapor state in the expansion process only after shunting the main part of current to the corona. However, it is possible another scenario of core structure formation if the current shunting occurs at an early stage of the explosion, for example, when the wire material is still in liquid state. In this case, due to a sharp drop of the compressive magnetic pressure, the core material can come into a state of the stretched melt during unloading. In accordance with the molecular dynamic calculations this metastable state decays, that resulting in to formation of a complex core structure: the outer cylindrical liquid shell filled with low-density foam. The foam decays into liquid droplets before the outer shell breaks apart. Simulated density profiles demonstrate good qualitative agreement with experimental high-resolution X-ray images showing the complex hollow structures within the long-living dense core.

This work was supported by the Russian Foundation for Basic Research project nos. 11-08-00624-a.

**STUDY OF REGULAR STRIATIONS AND GAPS ACCIDENTALLY
FORMED DURING WIRE EXPLOSION**

**S. I. Tkachenko^{1,2}, T. A. Khattatov¹, V. M. Romanova³,
A. R. Mingaleev³, R. B. Baksht⁴, V. I. Oreshkin⁴, T. A. Shelkovenko³,
S. A. Pikuz³**

¹*Moscow Institute of Physics and Technology, Dolgoprudny, Moscow
Region, Russia,*

²*Joint Institute for High Temperatures, RAS, Moscow, Russia,
svt@ihed.ras.ru,*

³*Lebedev Physical Institute RAS, Moscow, Russia*

⁴*Institute of High-Current Electronics, SB RAS, Tomsk, Russia*

In the present study, the mechanism of formation of cross-sectional striata and core gaps during electric explosions of 25- and 50- μm -diameter copper and nickel wires in air is investigated. Experiments were performed with the parameters that correspond to regime with the current pause; so the wire material is freely expanded after switching off the current. We presented experimental and theoretical results indicating that the striations caused by thermal instability. It is shown that the process of thermal conductivity, as well as more rapid evaporation of shallow striations is the mechanism of increasing the wavelength of the striations. It is also shown that the specific energy deposited in the gap region substantially exceeds the average specific energy deposited in the wire material.

This study was supported by the Russian Foundation for Basic Research (project 11-08-00624).

TWO-TEMPERATURE MODEL FOR THE SOLID METALS AT HIGH ENERGY DENSITIES

N.B. Volkov^{1,2}, E.A. Chingina¹, A.P. Yalovets^{1,2}

¹ *Institute of Electrophysics UB RAS, Russia, Yekaterinburg,
nbv@ami.uran.ru*

² *South-Ural State University, Russia, Chelyabinsk,
yalovets@physicon.ac.ru*

Physical processes, taking place in metals during the electromagnetic energy intensive flows pulse impact, depend essentially on its duration and intensity. If impact duration (τ_b) is less or close to the time of electron-ion matter components equilibrium establishment ($\tau_\varepsilon \sim 10^{-12}$ c), than non-equilibrium state is excited in the metal. If thereat $\tau_b \sim \tau_\varepsilon \gg \tau_p \sim 10^{-14}$ s (τ_p is a time of an establishment of the local momentum balance in each of the substance component), then excited state represents the non-equilibrium non-isothermal plasma-like medium in which the electronic temperature T_e essentially exceeds the lattice temperature T_i . The relaxation of such excited state is possible to consider within the framework of two-temperature approximation of the continuum electrodynamics and mechanics.

While in ground state the energy of interaction of ions with the whole electronic subsystem, complying with Fermi-Dirac statistics, and elastic stress tensor both depend on the condensed matter metric tensor. For energy and pressure at $T_i=T_e=0$ we obtained the expressions, maintaining correct asymptotic at $\rho \rightarrow \rho_\infty < \rho_r$ (ρ_r is density since which it is necessary to take into account, that electronic subsystem is relativistic). The conductivity electrons contribution at $T_e=0$ is taken into account in interaction energy. Their contribution to the thermodynamic functions at $T_e>0$ and concentration are defined via atomic cell volume and T_e within the Thomas-Fermi model with quantum and exchange corrections, where to the chemical potential were added corrections to represent the electronic subsystem at normal density (ρ_0) correctly. The equilibrium phonon gas contribution to the thermodynamic functions of the solid body with mono-atomic cell is taken into account within the Debye model. Herein both long- and short-wave perturbations contribution is effectively taken into account for the atomic cell volume dependent phonon gas energy spectrum. Suggested expressions for Cu, Au, Ag, Al and W thermodynamic functions description are tested through the theoretical and experimental shock Hugoniot curves comparison at $T_e=T_i=T$.

The method of taking into account the dynamics of electron and phonon gases in metals having topological defects within the classic fields gauge theory is discussed. The kinetic coefficients for electrons can be found solving the kinetic equation, where topological defects presence in both mean field and collision integral is effectively taken into account, written within τ -approximation.

The work is carried out under partial financial support of the RFBR (project No. 10-08-00691-a), the Presidium of UB RAS within the program for basic research of the Presidium of RAS «Matter at high energy densities» (project No. 12-II-2-1005) and junior scientists and postgraduate students research support (project No. 11-2-НП-590).

CONTROL OF HIGH-POWER ULTRAWIDEBAND RADIATION PULSE SPECTRUM

Yu. A. Andreev, V.I. Koshelev, I.V. Romanchenko, V.V. Rostov, K.N. Sukhushin

*Institute of High Current Electronics SB RAS,
2/3, Akademicheskoy ave., Tomsk, 634055, Russia, E-mail:
andreev@lhfe.hcei.tsc.ru*

Realization of the concept of adaptive radar requires a source of ultrawideband (UWB) radiation with controlled spectrum. The objective of the work was creation and research of a prototype of this source.

The SINUS-200 pulser allows generating pulses of the duration 8 ns FWHM and voltage rise time of 2÷3 ns at the half amplitude. Voltage amplitude is determined by pressure in the gas switch operating in a self-breakdown mode. In the mode of single pulse generation, the amplitude at the nonlinear line input varied in the limits of 135-300 kV. Maximum voltage pulse amplitude at the nonlinear line input was equal to 250 kV at the pulse repetition rate of 50 Hz.

The nonlinear line is partially filled with saturated-state NiZn ferrite. An impact wave front from the pulser excites the magnetization precession. As a result, a train of high-frequency oscillations superimposed on the videopulse is formed. The bandpass filter was used to extract a high-frequency component which passes through a filtering capacity forming a voltage pulse of the maximum energy 1.6 J and peak power 2.8 GW in the combined antenna feeder.

Research of the combined antenna characteristics was carried out in the frequency and time domain. Antenna characteristics in the free space and in the dielectric container were investigated. The combined antenna without the container had VSWR of < 2 in the frequency band of 0.4-1.8 GHz. The patterns were stable in the frequency band of 0.4-1.5 GHz. Influence of the container on the antenna directional characteristics in the frequency range $f > 1$ GHz was demonstrated.

Central frequency tuning of the radiated UWB pulse was supported both by the bias field of the nonlinear line and by the voltage amplitude change at the nonlinear line input. Effective radiation potential of the source determined as a product of the electric field peak strength multiplied by the distance in the far-field zone varied in the limits of 95-310 kV. The tuning range of the radiation spectrum central frequency was 0.5-1.3 GHz at the transmit-

ting antenna bandpass equal to 0.4-1.5 GHz. Energy efficiency of the source increases with voltage rise and at maximum voltage at the nonlinear line input equals to 4.5 %. Estimation of the radiation peak power is 1 GW. The source was tested in the single pulse radiation mode and at the pulse frequency rate of 50 Hz.

CONNECTYED IN PARALLEL

**A. Yu. Arbuzov., V. A. Avgustinovich, S. N. Artemenko,
V. L. Kaminsky, S. A. Novikov**

*Tomsk Polytechnic University, Tomsk, Russia,
e-mail: tpu-scientist@tpu.ru*

Synchronous operation of storage connected in parallel increases a maximum permissible output power level of a microwave compressor; an oversized cavity used in a compressor increases the amplification factor. These two characteristic properties were used jointly in the microwave compressor design; results of the experimental study of the S-band compressor of the type are presented. The energy was extracted through smooth transitions and the circular waveguide bridge comprising the oversized section where the switch was located. It was noted the design maintains small overall dimensions, high efficiency and amplification factor values. Measurements showed the source provided steady nanosecond pulses at repetitive operation mode up to 100 Hz of 0.4 GW power for each cavity. Combined output pulses were of 0.8 GW pulse power at the amplification factor value of 22 dB.

GASEOUS NITROGEN LASER IN SYSTEM OF MICROWAVE SWITCH TRIGGERING

**M. S. Arteev, V. A. Avgustinovich, S. N. Artemenko,
V. L. Kaminsky, S. A. Novikov, Yu. G. Yushkov**

Tomsk Polytechnic University, Tomsk, Russia, yuyu@tpu.ru

Synchronous energy extraction of the two S-band microwave compressors was provided by laser triggering. The laser provided pulses of 0.5 mJ energy and 5 ns pulsewidth. Gaseous switches were filled with nitrogen or argon-SF₆ mixture. The cavity was excited by microwave pulses of 2 MW pulse power and 3 mcs pulse width generated by the magnetron tube. The output power of each cavity reached 250 MW at the pulse width of 4 ns. Laser triggering contributed to steady operation of the switches and to practically ideal combining of output pulses at repetition frequencies up to 25 Hz. The increase of the total output power up to 1 GW of the resonant compressor cavities connected in parallel is discussed.

THE COMMUTATION OF RESONANCE MICROWAVE COMPRESSORS BY LASER RADIATION

M.S. Arteev, S.N. Artemenko, Yu.G. Yushkov

TPU IPT, Tomsk, Russia, art.@tpu.ru

Results of a few experimental tests concerning the laser triggering of microwave switching discharges into resonance compressors are presented. On the basis of these results obtained the threshold density values of ultraviolet radiation for microwave compressor switching of high frequency field strength which was observed in experiments in the area of discharge formation. The switching time value were measured and required number of initial electrons is estimated. It is shown the most probable physical process of producing this electrons number is the step fotoionization of nitrogen molecules during the laser radiation exposition. On the basis of experiments and theoretical study the possibility of generation of more than 1 GW microwave pulses nanoseconds duration with high repetition rate and stability is validated.

**OPERATION OF TWO OVERSIZED CAVITIES IN
MICROWAVE COMPRESSOR THE FORMATION
OF A RESONANT MICROWAVE PULSE COMPRESSOR
WITH ADJUSTABLE PARAMETERS**

S.N. Artemenko¹, V.A. Avgustinovich¹, A. Shlapakovsky²

¹ *Tomsk Polytechnic University, 30 Lenina str., Tomsk, 634050, Russia,
yuyu@tpu.ru*

² *Teknion, Haifa, Israel*

This paper describes the results of study a resonant microwave compressor with the energy extraction through the interference switch based on H - tee as a source of pulses with adjustable power and energy, pulse width and carrier frequency. The adjustment of pulse parameters is based on the tuning of interference switch transition attenuation. The theoretical estimation of adjustable parameters range and the results of experimental research the S-band compressor with adjustable parameters of output pulses were provided. The research shows that it is possible to obtain nanosecond microwave pulses with fixed parameters so well as pulses of microsecond duration with variable power, energy, and carrier frequency and tunable combined pulses of microsecond and of nanosecond duration. In particular, the article demonstrates that it is possible to form pulses of microsecond duration with power and energy being regulated in the range up to 43 dB; combined pulses of microsecond and nanosecond duration, with power and energy of microsecond part of pulse being regulated up to ~43 dB and nanosecond part of one being regulated up to 7dB, and the carrier frequency in the band being regulated ~ 0.2%.

**PATTERNS OF PEAK POWER AND ENERGY OF
ULTRA-WIDEBAND PULSE RADIATION FROM APERTURE
ANTENNAS**

V.M. Fedorov, V.Ye. Ostashov, A. V. Ul'yanov

*Joint Institute for High Energy Densities of RAS.
13/2, Izhorskaya str., Moscow, 127412, Russia, vmfedorov@ihed.ras.ru*

Angular spatial distributions of peak power and energy are analyzed for ultra-wideband pulsed (UWB) radiation which is produced by aperture antennas of TEM-horn type. Application of two patterns of peak power and energy for description of the UWB radiation is necessary to use because waveforms of radiated field are change for various directions at far distance. The subjects of this research are the UWB radiators which have been constructed in our laboratory. High power radiators were created with the TEM-horn antennas exciting by sub-nanosecond unipolar pulses of high voltage generators. Quantitative relation is analyzed between the energetic directivity factor D of antenna and the angle $\Delta\theta(0.5P_{max})$ of characteristics for the pattern of peak power of radiation flow. We provide comparisons of results with use experimental data and results of calculations. One model is like Huygence unidirectional radiators excited by modified voltage pulse of the high power generator after transmission of the pulse through model filter.

**SIMULATION OF COMPRESSION IN THE CAVITY OF THE
MICROWAVE PULSES WITH OUTPUT ENERGY OF THE OSCIL-
LATIONS TRANSFORMATION**

**V.S. Igumnov¹, V.A. Avgustinovich¹, S.N. Artemenko¹,
S.A. Novikov¹, Yu.G. Yushkov¹**

¹ *Tomsk Polytechnic University, Physical-Technical Institute,
30 Lenina str., Tomsk, 634050, Russia, igumnov@tpu.ru*

The results of experimental studies of the interaction modes of communication on the window of a multimode waveguide resonator with a short train are presented. The experimentally determined dependence of the mode coupling parameters of the plume and windows due to the loop resonator.

Based on these experiments, the model of the process of energy transfer from mode to mode in the microwave compressor with the output power fluctuations in the transformation of the resonator box with a train. Model describing a relation between the parameters of output pulses and the parameters of the compressor device mode coupling, which qualitatively agrees well with experimental data.

DESIGN OF L BAND 20 KW HIGH POWER SOLID STATE AMPLIFIER FOR TARLA / TAC PROJECT

O.Karsli, O.Yavas¹, M. Dogan²

*Institute of Accelerator Technologies, Ankara University, Gölbaşı, Ankara,
karsliozlem@yahoo.com*

¹ *Department of Physics Engineering, Ankara University, Tandoğan, Ankara,
yavas@ankara.edu.tr*

² *Department of Control Engineering, Dogus University, Kadıkoy, Istanbul,
mustafa.dogan@gmail.com*

The Turkish Accelerator Center (TAC) Project is proposed as a national center that will contain MeV and GeV scale electron and proton accelerators. The Turkish Accelerator and Radiation Laboratory at Ankara (TARLA) is, an IR FEL oscillator and Bremsstrahlung facility and planned as a first facility of the TAC project. The buildings of TARLA facility and Institute of Accelerator Technology of TARLA have been constructed in Gölbaşı Campus area of Ankara University at Ankara. Currently, TARLA facility is ready for the installation of the accelerator and oscillator components. TARLA will consist of two optical cavity system to produce 2-250 μm oscillator FEL in infrared region and Bremsstrahlung radiation using 10-40 MeV electron beam energy. It will compose of two superconducting electron accelerator modules having two 1.3 GHz TESLA RF cavities for each. Thermionic DC gun is manufactured as an electron source in Ankara and its installation is still in progress. Two superconducting modules and He cooling system are currently under production. High power RF system of TARLA will have four RF stations controlling by low level RF unit to transmit equal amount of RF power into the superconducting modules simultaneously. It is proposed that TARLA will be operated by 20 kW solid state power amplifiers. The RF power transmitted into the TESLA RF cavities will be net 16 kW. Since there is no available

1.3 GHz 20 kW solid state power amplifier, it will be a new development for TARLA. Low Noise and stability are indispensable requirements for this application.

It is planned to design a compact and a robust L band 20 kW RF amplifier by using multiple gallium nitride (GaN) RF high electron mobility transistors (HEMTs) due to high power capability, stability and noise immunity at given frequency range. Multi-stage Class AB structure will be utilized for inherent linearity and efficiency properties. Furthermore, thermal stability of the amplifier will be investigated at large. In this research, design and simulation results of 20 kW TARLA high power solid state RF amplifier are explained.

CALORIMETER FOR MEASURING HIGH POWER MICRO-WAVE PULSE ENERGY

**A.I. Klimov,^{1,2} P. V. Vykhodtsev,¹ O. B. Kovalchuk,¹
and A. N. Sinyakov¹**

¹ *Institute of High Current Electronics, SB, RAS, 2/3 Akademicheskoy Ave.,
Tomsk 634055, Russia, e-mail: klimov@lfe.hcei.tsc.ru*

² *National Research Tomsk Polytechnic University, 30 Lenin Ave.,
Tomsk 634050, Russia*

An X-band calorimeter is described that was used to measure the energy of high power microwave (HPM) pulses. The calorimeter construction includes a conical horn in the aperture of which a three-layer (polyethylene/ethyl alcohol/polyethylene) microwave absorber is placed. The calorimeter is connected to the evacuated output of the HPM oscillator. The microwave power flow of the operating wave E_{01} transfers through the calorimeter horn and is dissipated in the absorber. The operation of the calorimeter is based on the expansion of the alcohol as its temperature increases due to microwave energy absorption. The degree of expansion is estimated by measuring the displacement of the alcohol meniscus in the glass capillary tube connected to the absorber. The displacement is observed with a video camera. The alcohol must be slightly preheated in order that the initial position of the meniscus could be controlled and fixed. There are two spirals in the absorber one of which is used to heat the alcohol and the other to calibrate the calorimeter. The design of the calorimeter was optimized in order to reduce the

probability of a microwave discharge and to moderate microwave reflection to a negligible level. The back wall of the absorber is closed with a stainless steel plate. The plate reflects microwaves back into the alcohol. This reduces the microwave energy losses and increases the measurement accuracy. There is a rectangular hole in the plate that serves as the microwave output of the calorimeter and allows a standard waveguide, a decoupling attenuator, and an efficient microwave detector to be connected. This makes it possible to record the microwave pulse shape in measuring the pulse energy and calculating its peak power. A stabilized HY3005 dc power supply is used for heating the alcohol in the absorber and a HY5003 dc power supply serves for calibrating the calorimeter. After modification, a rectangular voltage pulse of duration 2 s and energy up to 143 J could be produced across the calibration spiral. The calorimeter was used for measuring the energy of subnanosecond microwave pulses of peak power $\sim 10^9$ W. The sensitivity of the calorimeter was about 2.4 J/mm and the total calibration error was about 10%.

TEST MEASUREMENTS FOR THE TRANSMITTING ANTENNA OF A RELATIVISTIC BWO

A. I. Klimov, V. V. Rostov

*Institute of High Current Electronics, SB, RAS, 2/3 Akademicheskoy Ave.,
Tomsk 634055, Russia, e-mail: klimov@lfe.hcei.tsc.ru*

Test measurements of the characteristics of an X-band relativistic BWO antenna system are described. The antenna system includes a conical horn with a resonance spherical vacuum window mounted in the horn aperture. Circular ripples are made on the internal surface of the horn to reduce the antenna pattern sidelobes. The BWO operating wave is the E_{01} mode of a cylindrical waveguide; therefore, a converter is connected to the horn throat to transform the wave into a Gaussian wave beam. The operating frequency band of the converter makes about 5% with the central frequency equal to 9.09 GHz. The BWO was intended to produce microwave pulses with a peak power of 300 MW; the power flux density of the pulses at a distance of ~ 1 m from the transmitting antenna was preliminary estimated to be 300 kW/cm^2 . The main problem in the actual experiment with the BWO was to determine this high microwave power flux density because its direct measurement using a waveguide antenna and an efficient microwave detector was very difficult.

The aim of the test measurements was to find an adequate method for solving this problem, and the experimental simulation of the BWO microwave pulse with the use of an X-band Gunn oscillator was chosen as the most appropriate. The Gunn oscillator produced microwave pulses whose maximum power amplitude was ~ 10 W, and the amplitude was controlled with the use of a waveguide attenuator. The pulse duration was ~ 20 ns. The carrier frequency and the pulse repetition rate were 9.09 GHz and ~ 1 kHz, respectively. The oscillator was connected to the converter via a waveguide-to-coaxial adapter and a coaxial *TEM*-to- E_{01} wave converter. The microwave power flux density distributions in the *E*- and *H*-planes were measured using a waveguide antenna at distances of 1.05 and 3 m from the transmitting antenna. The Gunn oscillator signal was observed using a waveguide directional coupler. The receiving antenna and coupler signals were detected with the use of a Schottky-barrier diode microwave detector and a digital oscilloscope. Comparing the microwave power flux density distributions, we have found the proportion between them, and extrapolating the 3-m distant microwave power flux density distribution from the Gunn oscillator power to the BWO power, we have estimated the BWO microwave power flux density at a distance of 1.05 m from the transmitting antenna.

SPECTRAL MEASUREMENTS OF HIGH POWER MICROWAVE SUPERRADIATIVE PULSES

A. I. Klimov,^{1,2} O. B. Kovalchuk, and A. N. Sinyakov

¹ Institute of High Current Electronics, SB, RAS, 2/3 Akademicheskoy Ave.,

Tomsk 634055, Russia, e-mail: klimov@lfe.hcei.tsc.ru

² National Research Tomsk Polytechnic University, 30 Lenin Ave., Tomsk 634050, Russia

Two X-band schemes intended for high power microwave (HPM) pulse spectral measurements are described in detail. The first one is a rather simple heterodyne scheme. In this scheme, the microwave signal produced at the output of a microwave calorimeter or a receiving antenna passes through standard D5-21 decoupling attenuators, coaxial-to-waveguide adapters, an RK50-4-47 coaxial radiofrequency cable, and a waveguide directional coupler and arrives at an X-band detector based on a Schottky-barrier diode be-

longing to the kit of a U3-29 amplifier. The detector is used as a mixer. A standard G4-83 oscillator is used as a heterodyne. The output intermediate frequency (IF) signal of the mixer is measured with a wideband digital oscilloscope. The oscilloscope FFT option is used for determining the signal spectral characteristics. The spectrum measured in such a way is corrected taking into account its distortion in the IF circuit of the mixer and in the receiving microwave signal circuit.

The second scheme uses a tunable waveguide band pass filter. The filter consists of an input/output waveguide and a resonant waveguide. The resonant waveguide is plunged perpendicularly into the input/output waveguide and contains a shorting plunger that can be moved with the use of a precise screw with a linear scale, thus allowing the filter to be frequency tuned. The filter was preliminary calibrated. The received microwave signal is transmitted through standard D5-21 decoupling attenuators, waveguide-to-coaxial cable adapters, an RK50-4-47 coaxial cable, and a waveguide coupler to the wideband detector. The signal from the output of the detector is measured with a wideband digital oscilloscope. To correct the distortion of the measured HPM oscillator spectrum, the coefficient of microwave transmission throughout the circuit from the receiving unit to the detector and the filter pass band were preliminary measured as functions of frequency and then were used in processing the signal.

Both schemes were used for measuring the carrier frequency and the spectrum of X-band HPM superradiance pulses produced by a relativistic backward wave oscillator.

**TESTING OF THE TRANSMITTING ANTENNA OF A
SUPERRADIATIVE BWO**

A. I. Klimov^{1,2}, O. B. Kovalchuk¹

¹ *Institute of High Current Electronics, SB, RAS, 2/3 Akademichesky Ave.,
Tomsk 634055, Russia, e-mail: klimov@lfe.hcei.tsc.ru*

² *National Research Tomsk Polytechnic University, 30 Lenin Ave.,
Tomsk 634050, Russia*

The characteristics of the transmitting antenna of a relativistic backward wave oscillator (BWO) have been measured. The superradiative BWO operated at a carrier frequency of 9.7 GHz and produced microwave pulses of peak power ~ 1.5 GW and duration ~ 0.7 ns at a repetition rate of 100 p.p.s. The antenna system included a wave converter and a conical horn with a plane polyethylene window in the horn aperture and transformed the BWO operating wave E_{01} into a Gaussian wave beam. The goal of the testing was to find a way for measuring adequately the characteristics of the BWO high power microwave (HPM) pulses at a distance of about 1.7 m from the antenna. An aperture attenuator was placed near the antenna window as the microwave power density at this distance was too high to perform direct measurements using a waveguide antenna and a detector. The attenuator was a three-layer (polyethylene/ethyl alcohol/polyethylene) structure. The structure was optimized to reduce microwave reflection. A Gunn oscillator was used in the test measurements that produced microwave pulses of peak power about 40 W and duration 8.6 ns at a carrier frequency of 9.7 GHz. The oscillator was connected to the waveguide circuit of the measuring system that included a waveguide-to-coaxial adapter and a TEM -to- E_{01} wave converter connected to the input of the antenna system. The microwave power density distributions in the E - and H -planes were measured at a distance ~ 1.7 m from the transmitting antenna with and without the aperture attenuator. The distributions made it possible to calculate the factor of decrease in microwave power density and the coefficient of power transfer from the transmitting to the receiving antenna at a distance of 1.7 m, and also to estimate the BWO-radiated pulse power by integrating the microwave power density distribution measured in the experiment with the BWO.

**THE INFLUENCE OF THE TRANSVERSE DIMENSION OF
MULTIWAVE CERENKOV OSCILLATOR ON THE SPATIAL
STRUCTURE OF THE RADIATION FIELD**

V.N.Kornienko, V.A.Cherepenin

*Kotel'nikov Institute of Radio-engineering and Electronics of RAS,
Moscow, Russia, korn@cplire.ru*

Generation of high power microwave in the devices of relativistic electronics requires to the use of oversized electrodynamic structures. An example of such a device is multiwave Cerenkov oscillator, which provided a record level of power in three-centimeter wavelength range. The radiation of the oscillator had axially symmetric transverse structure.

The influence of transverse size of the electrodynamic structure on the quality of the electromagnetic field was the aim of this research. The main method of research was computer simulation techniques. It was based on self-consistent numerical model solutions of the problem of motion of charged particles and the dynamics of the electromagnetic field.

We considered a basic version of the device structure with a diameter of 7 cm. Total beam current was about 20 kA, kinetic energy of electrons – 2MeV. In this case the averaged output power achieved 9 GW. Obtained characteristics of the radiation field were used for comparison with the results corresponding to different diameters of the structure. In all the computational experiments, the following parameters were constant: the density of the beam current, initial energy of particles, the magnitude of the leading magnetic field, the longitudinal structure of the system. The report presents the results obtained for smaller (3.5 cm) and larger (14 cm) diameters of electrodynamic structure. It is shown that the radiation is still coherent for transverse sizes, which exceed the base case.

**HIGH-POWER SOURCE OF ULTRAWIDEBAND RADIATION
WITH WAVE BEAM STEERING**

V. I. Koshelev, A. M. Efremov, B. M. Kovalchuk, V. V. Plisko

*Institute of High Current Electronics SB RAS
2/3, Akademichesky ave., Tomsk, 634055, Russia, E-mail:
koshelev@lhfe.hcei.tsc.ru*

One of most important applications for high-power pulses of ultrawideband (UWB) radiation is radar with high spatial resolution. To create radar, it is necessary to have UWB sources with wave beam steering.

In this work, a new scheme of the high-power UWB source was realized for the first time: a monopolar pulse generator – a bipolar pulse former unit – an antenna array. In this scheme, the number of bipolar pulse formers and antennas in the array is equal which allowing realizing a wave beam steering mode.

A high-power nanosecond-length source of UWB radiation is described. Four output bipolar pulses of the source can be synchronized in the time of transition trough zero with a root-mean-square deviation of less than 100 ps or delayed by the moment of this transition in some formers relative to the others for the time up to 300 ps by pressure control in two-electrode gas switches. The switchers operate in a self-breakdown mode. At a 3-ns bipolar pulse length, the effective potential of radiation was equal to 400 kV at the pulse repetition rate of 100 Hz. The overall time of the UWB source operation without electrode replacement at the pulse repetition rate of 100 Hz exceeds five hours. Amplitude instability of the electric field of radiation is no higher than 5%. Possibility of wave beam steering in the limits of 10° was demonstrated as well.

**LINEAR POLARIZED RADIATION IN MULTIWAVE
CHERENKOV GENERATOR****V. I. Koshelev, M. P. Deichuly**

*Institute of High Current Electronics SB RAS
2/3, Akademichesky ave., Tomsk, 634055, Russia, E-mail:
koshelev@lhfe.hcei.tsc.ru*

In high-power sources of microwave radiation with longitudinal interaction of relativistic electron beam and electromagnetic field, including multiwave Cherenkov generators (MWCG), a radiation pattern is formed with radial polarization and field minimum in the centre. For applications, wave beams with linear polarization and field maximum in the centre are necessary. Transformation of radially polarized MWCG radiation into linearly polarized one is realized with low efficiency.

In the paper, a 3-cm wavelength range multiwave Cherenkov generator with linear polarization of radiation and Gaussian field distribution was suggested and realized.

For this purpose, overmoded ($D/\lambda \approx 4$, D – is the diameter, λ – is the radiation wavelength) azimuthally non-symmetric sectioned slow-wave structures were used. The waveguide surface in the azimuthal direction consists of two smooth and two diaphragmatic parts. This allowed obtaining the mixture of the E- and H-waves with the azimuthal index equal to 1 and different ratio of mode amplitudes.

The experiments were carried out at a SINUS-7M nanosecond accelerator at the diode voltage of 520 kV, beam current of 8.6 μ A and magnetic field of 4 - 5 kGs. A diaphragm cutting off 43% of the beam current near the smooth surfaces of the waveguide was installed in front of the slow-wave structure. Pulses of linearly polarized radiation of the power 850 MW were obtained at the field distribution close to the Gaussian and efficiency of 30%. The power of the cross-polarized radiation was less than 10%.

To use the hollow electron beam current completely, investigations on synchronization of two MWCGs with non-symmetric slow-wave structures installed in-series along the system axis and turned perpendicular to each other in azimuth were carried out. In the first experiments, the power of linearly polarized radiation increased by 1.5 times in comparison with a single MWCG.

**EXCITATION OF ELECTROMAGNETIC OSCILLATIONS OF THE
LOWEST TYPES IN A FLAT-COAXIAL REFLEX TRIODE**

A.L. Marchenko, T.V. Koval

*National Research Tomsk Polytechnic University, 30, Lenin Avenue
Tomsk, Russia, e-mail: tenorasp@mail.ru*

The theoretical and numerical investigations of electromagnetic oscillations excitation in the flat-coaxial triode with virtual cathode is carried out. The analytical model allowing to estimate a level of resonant interaction between virtual cathode fluctuation and the resonator eigenfields is used when this systems with various parameters of beam and resonator is investigated. The virtual cathode formation and high power microwave generation are numerically studied by 3-D particle-in-cell code KARAT. It is shown, that electron beam interacts more efficiently with lowest axially nonsymmetrical mode H_{11} and dispersionless wave TEM.

**INVESTIGATION OF THE INFLUENCE OF THE ANODE
CURRENT MAGNETIC FIELD ON THE BEAM ELECTRONS
MOVEMENT IN REFLEX TRIODES**

A.L. Marchenko, T.V. Koval

*National Research Tomsk Polytechnic University, 30, Lenin Avenue
Tomsk, Russia.
e-mail: tenorasp@mail.ru*

In the paper the theoretical study of influence of own electron beam magnetic field and magnetic field of anode current on electrons dynamic in coaxial and flat-coaxial reflex triodes with divergent beam is carried out. The shift of electrons trajectories along longitudinal coordinate in reflex triode and diode are shown. This course irregular redistribution of beam density that effects virtual cathode formation and efficiency of resonant interaction between electron beam and coaxial resonator eigenfields. The condition of self-isolation of beam showing when electromagnetic radiation in triode became impossible is determined.

STUDY OF ELECTRODYNAMIC AND RADIATION CHARACTERISTICS OF A COAXIAL AND A PLANAR-COAXIAL VIRCATOR

M.T. Nguyen, T.V. Koval, A.G. Zherlitsyn¹, G.G. Kanaev¹

Institute of Cybernetics, Tomsk Polytechnic University, Tomsk, Russia,

*¹Institute of Physics and Technology, Tomsk Polytechnic University,
Tomsk, Russia*

nguyenminhtuan@mail.ru

The numerical study of eigenfield and resonant frequencies of electrodynamic system of planar-coaxial and coaxial vircators is carried out. The analysis of mode composition of electromagnetic radiation in these vircators, as well as the analysis of numerical and experimental radiation pattern is conducted. It is shown that mode composition of radiation and the degree of electron beam heterogeneity can be determined by the radiation pattern. Using an input voltage pulse with peak value of 550kV the average voltage obtained on the diode is 450 kV and the diode current is 50 kA, the peak values of output microwave power of coaxial and planar-coaxial vircator are observed to be over 200 and 100 MW respectively in frequency band 2.95 – 3.1 GHz.

EXCITATION OF TE_{11} MODE IN THE PLANAR-COAXIAL TRIODE WITH VIRTUAL CATHODE

M.T. Nguyen, T.V. Koval, A.G. Zherlitsyn¹, G.G. Kanaev¹

Institute of Cybernetics, Tomsk Polytechnic University, Tomsk, Russia

*¹Institute of Physics and Technology, Tomsk Polytechnic University,
Tomsk, Russia,*

nguyenminhtuan@mail.ru

The theoretical study of TE_{11} excitation in the triode with virtual cathode is carried out using KARAT, a three-dimensional PIC computer code. The structures of wave fields, the resonant frequency of the resonator and wave energy transfer are investigated. Experimental study of electromagnetic radiation generation in the generator is also reported. It is shown that sin-

gle-mode generation of TE_{11} mode in the triode with virtual cathode is possible. The output microwave power with peak value over 100 MW are observed in frequency band 2.95 – 3.1 GHz.

**SINGLE CAVITY MICROWAVE COMPRESSOR WITH TWO
PARALLEL OUTPUTS**

**S. A. Novikov, V. A. Avgustinovich, S. N. Artemenko,
V. L. Kaminsky, Yu. G. Yushkov**

Tomsk Polytechnic University, Tomsk, Russia, nsa@tpu.ru

High power microwave nanosecond pulses are promising for particle acceleration, low observable object radiolocation and electronic equipment susceptibility tests. They can be generated by the procedure of microwave energy compression that is resonant excitation of a high Q-value cavity with following fast energy dumping. The output power value is limited by electric strength of the switch gap and the design studied in this report is meant to overcome the limitation. The device contains the relatively long cylindrical cavity with two output ports. Their particular location divides the length of the cavity into four practically equal sections and the energy was dumped simultaneously from said sections. Then the radiations of two output ports was combined in the T-junction and transmitted to a common load.

Experimental tests were run in S-band. The output pulse power at each output port was 400 – 500 MW and the total combined power reached 0.8 – 1 GW. The output pulse width was 4 – 5 ns at the power amplification factor of 22 – 23 dB. The repetition rate was up to 100 Hz and high stability of the output pulse envelopes was observed. The steady operation of the compressor required the gas insulation of the cavity volume.

HIGH POWER 4 CHANNEL GYROMAGNETIC RF SOURCE

**I. V. Romanchenko, V. V. Rostov, A. I. Klimov, I. K. Kurkan,
A. V. Gunin, K. N. Sukhushin, V. V. Plisko, A. N. Sinyakov,
V. O. Kutenkov**

*Institute of High Current Electronics SB RAS, 2/3, Akademichesky ave.,
Tomsk, 634055, Russia E-mail: riv@lfe.hcei.tsc.ru*

This paper describes the four channel 100 Hz repetitive rf source based on gyromagnetic nonlinear transmission line. The high voltage pulse from SINUS-200 high voltage driver excites rf oscillation in NLTL with saturated ferrites at 1.5 GHz central frequency. A band-pass filter and 4 channel splitter have been designed to extract rf pulse from low-frequency component and to form rf pulse at 4 wideband 50 Ω resistive loads. The peak power of 120 MW in each channel was achieved. It is shown that pressurizing enables the NLTL to operate for more than 10^5 pulses without breakdown.

HIGH POWER MICROWAVE GENERATION IN SEMICONDUCTOR DIODE

S.N. Rukin, S.K. Lyubutin, B.G. Slovikovsky, S.N. Tsyranov

*Institute of Electrophysics UD RAS, Ekaterinburg, Russia, e-mail:
rukin@iep.uran.ru*

Generation of powerful microwave voltage oscillations in diffused silicon diode has been studied. The reverse current of 2 kA in amplitude passed through the diode having the width of 320 μm , p - n junction depth of 220 μm , and surface area of 0.5 cm^2 . At an average voltage level across the structure being around 300 V and microwave voltage pulse duration of ~ 200 ns the maximum voltage swing of the observed oscillations reaches 480 V. The frequency of the oscillations is 5 to 7 GHz, and the microwave power of the oscillations attains ≈ 300 kW. The theoretical analysis of the oscillation mechanism is presented. It is shown, that the frequency and the voltage swing of the oscillations depend on the current density, and the gradient of the doping impurity concentration in the vicinity of the p - n junction.

Experimental data and numerical simulation results will be presented and discussed.

THE COMPRESSION OF MICROWAVE PULSES IN SUPER- CONDUCTING RESONATORS

G.M. Samoylenko, S.N. Artemenko, V.L. Kaminsky

*Tomsk Polytechnic University, Institute of Physics and Technology,
2A Lenina str., Tomsk, 634050, Russia, sgm@tpu.ru*

The results of the study of the main characteristics of superconducting resonant microwave compressors are presented.

It is shown that superconducting storage cavities (SC) can improve parameters of the pulse microwave compressors significantly. They either increase the order of the amplification factor by 4...6 at the pulsewidth values usual for ordinary compression systems or increase the pulsewidth of produced pulses by order of 3...4 at the amplification factor values provided by ordinary system.

It is shown also that working frequency band of SC resonant microwave compressors is twice as large as in common systems. The output pulse power of SC compressors can reach values comparable to ones of compressors with ordinary cavities.

Experimental study of microwave energy storage in SC and fast energy extraction basically proves the calculations. It is shown that known methods and corresponding designs for energy extraction in usual systems - Q-factor modulation when the interference switch is used for the cavity-load coupling control, field pattern transformation in the cavity volume, inversion of the feeding wave phase – can be employed for switching SC from storage mode into extraction one.

The experimental values of the output pulse duration and the power amplification factor were 30...1000ns and 33...9,5dB respectively for different methods of energy extraction.

COAXIAL MODERATELY RELATIVISTIC L-BAND BACKWARD WAVE OSCILLATOR

**R. V. Tsygankov, V. Y. Konev, E. M. Totmeninov, V. V. Rostov,
I. V. Pegel, S. A. Kitsanov, and A. I. Klimov**

*Institute of High Current Electronics SB RAS, 2/3 Akademichesky ave.,
Tomsk, 634055, Russia, Phone:+7(3822)492-652, Fax:+7(3822)492-410,
E-mail: tsygankov@lfe.hcei.tsc.ru*

The paper reports on numerical and experimental research in a coaxial L-band backward wave oscillator (CBWO) with an electron beam energy of ~ 300 keV. The oscillating mode with a 150 MW power and ~ 30 % oscillator efficiency at an operating TEM mode with 1.2 GHz was calculated in axially symmetric geometry by the PIC-code KARAT. The radiation wavelength was three times larger than the mean diameter of the CBWO slow wave structure.

In experiments, a coaxial TEM-to-circular H_{11} waveguide mode converter was connected to the oscillator output, making possible a radiation pattern with a maximum on the system axis. In preliminary experiments, stable single-mode microwave pulses with a peak power of ~ 110 MW at an oscillator efficiency of 11 % were obtained at the output of the microwave source; the operating frequency was 1.23 GHz. The design of the CBWO electrodynamic system ensured selective excitation of the symmetric operating mode.

SWITCHING OF H_{11} -MODE WAVE OF 0.5 GW POWER IN CIRCULAR WAVEGUIDE

**Zhukov A.A., Avgustinovich V.A., Artemenko S.A., Kaminsky V.L.,
Novikov S.A.**

*Tomsk Polytechnic University
30, Lenina str., Tomsk, 634050, Russia*

Switching of the high power H_{11} -mode wave in a circular waveguide is of definite interest for phase shifters in transmission lines and storage cavities of microwave compressors. Microwaves of power values about 500 MW are

switched by formed discharge plasma in gaseous medium under high pressure. The discharge volume is inside a quartz tube and thus is isolated from the storage volume of the cavity. Transients of transmitted, reflected and dissipated wave signals during switching in nitrogen, argon and argon-SF₆ mixture are studied. Conditions of efficient switching in the oversized circular waveguide and in the short-circuited arm of the circular waveguide H-tee used in a capacity of an interference switch are determined. The power attributed to the travelling wave of said level in the cavity was achieved when the 2.5 MW magnetron driver was used for excitation of the cavity. The switches of this type if installed in resonant S-band compressors could allow forming nanosecond microwave pulses of 1 GW power and of repetition frequency value up to 100 Hz.

**THE LOW SCALE SOFT X-RAY NANOSECOND PULSE
RADIOGRAPH BASED ON THE X-PINCH**

A.P. Artyomov, M.G. Bykova, S.A. Chaikovsky, A.A. Erfort, V.F. Feduschak, A.V. Fedunin, I. V. Lavrinovich, V.I. Oreshkin, N.A. Ratakhin, A.G. Rousskikh, A.S. Zhigalin, N.V. Zharova

*Institute of High Current Electronics SB RAS, 2/3, Akademichesky ave.,
Tomsk, 634033, Russia*

Phone: 8(382-2) 492-133, e-mail: aap545@gmail.com

Soft x-ray sources based on the X-pinch are attractive for projection radiography of various short-lived physical objects. Using a small scale pulsed generator as a driver it is possible to realize portable installation for soft x-ray radiography with nanosecond temporal and micron spatial resolutions which could be transported to any laboratory.

The report is devoted to description of the low scale soft x-ray radiograph developed in the Institute of High Current Electronics. The radiograph consists of the base block, the control system, the vacuum system, the dry air system and diagnostics. The base block with diameter of 560 mm and the height of 410 mm is placed on the support with the length of 1100 mm and the width of 700 mm. The control system is placed near the base block and takes the laboratory area of 600x800 mm. The control system is connected with the command computer, placed in the Faraday cage, via optical fiber line. The base block includes the fast capacitor bank with capacitance of 1000 nF and the vacuum chamber with the load block. The bank charging voltage is 30-50 kV. An x-pinch or metal plasma jet could be used as a load. With the X-pinch made from the four 25 micron molybdenum wires the radiograph source size is 4 microns with the radiation pulse duration 2 ns in the spectral range 3-4 keV. Using a metal plasma jet formed with auxiliary vacuum arc discharge the radiation source with the size of 15 microns and the pulse duration 2-3 ns in the spectral range higher 1.5 keV could be realized. The auxiliary vacuum arc discharge system also is included in the control system. The advantage of the metal plasma jet load is capability to operate without reloading of the radiograph as it is required with an X-pinch. The soft x-ray pulse energy is enough high to provide the certain exposition of the MIKRAT and RF-3 films at the distance of 1000 mm.

POWERFUL TWO-STAGE DC BREAKER

O.G.Egorov

TRINITI, Moscow reg., Troitsk, egorov@triniti.ru

Wide application of the high power pulse devices based on the capacitor storages (CS) is facilitated by the property of the closing switch - discharger which provides: a high ratio $t_d/t_t \sim 10^6 - 10^7$, where t_d is the time of energy accumulation in CS and t_t is the time of energy transfer to the load, switching to any complex load, a high resource of over $\sim 10^5$ pulses, i.e. low erosion of the electrodes, and a high level of synchronization at parallel operation.

The inductive storages (IS) failed to find wide application, though they have a higher density of energy and high reliability. In addition, they are simple in design and low in cost. The IS energy is transferred to the load by way of an opening switch. Despite the great variety of the modern dc switching equipment of gigawatt power and millisecond pulse duration, due to its physical mechanisms of interruption, time of energy extraction, power of the interrupter and so on, this equipment proves to be unique being a subject to individual production with a low resource and high cost. This means, that to be broadly applied as storage of energy in pulse generators, the inductive storage needs in building an opening device with such properties that are inherent to closing devices, i.e. with a minimum configuration of components and normal control. In other words, it is necessary to get a technically acceptable and economically feasible construction on the basis of modern electrical components [1,3].

The current paper describes a number of technical solutions which transform the two-stage interrupter into the unit with its characteristics close to those of the discharger: the high resource of 10^4 and more [4-6], and ability of repeating pulses [7] and operating for any load. The proposed circuit of the two-stage switch in combination with the inductive storage can cover practically the whole range of applied tasks that could be solved in the mode of both a single pulse and series of pulses at multimegawatt powers and millisecond pulse duration. Among the tasks to be solved is the generation of laser-pulse ionization- and intense microwave radiations, acceleration of particles and EM-launch, fusion research, powerful pulse location, geophysics, and, at last, generation of long-pulse neutron radiation.

1 Physics and technology of high power. //Ed. E.P.Velikhov, M.: Energoatomizdat, 1987, 352p.

- 2 Physics and technology of electromagnetic energy of high density. // Ed. by B.D Selemir and
 3 L.N.Plyashkevich, M., Energoatomizdat, 2003, 555p.
 4 Opening switches //Ed. A.Guenther, M.Kristiansen, and T.Martin, PP, NY, 1987.
 5 O.G. Egorov Patent No.2299487, 22.09.2005, Russian Federation
 6 O.G. Egorov // Proc. XXIIInd ISDEIV, Matsue, Japan, 2006.
 7 O.G. Egorov // 2th Proc. EAPPC, Lithuania, September, 2008.
 8 O.G. Egorov //Proc. 18th PPC, Chicago, USA, 2011.

THE GENERATOR OF HIGH-PWER NANOSECOND PULSES ON THE BASIS OF INDUCTIVE ENERGY STORAGE

O.G.Egorov

TRINITI, Moscow reg., Troitsk, egorov@triniti.ru

The generation of multiterawatt power pulses of nanosecond duration is associated, first of all, with the problems of primary accumulation of energy and its transfer to the load. At present, in spite of their low density and high cost, the capacitor storages are the most widely used. This is due to the properties of the closing device which permits providing a high ratio of the times of energy accumulation ($-t_a$) and extraction ($-t_t$), which achieves the value of $\sim t_a/t_t \sim 10^6—10^7$ and more. Though the inductive storages are perspective because of their simplicity in design, energy density and cost, the problems with their application are connected with the current breaking gap, i.e. with the transfer of energy to the load. Some modern breakers, at their best, at high powers ensure the ratio of $\sim t_a/t_t$ not in excess of $\sim 10—20$ [1,2].

In a number of works, with the goal of using the inductive storage to generate nanosecond pulses, some solutions have been proposed including the combination of the vacuum interrupter and plasma opening switch [3,4] and generator-amplifier [5].

These works did not shed more light on the efficiency of the energy extraction from the transformer inductive storage that depends on a special screen designed to reduce the impact of the electromagnetic field to the primary winding.

As known, there exist two physical factors resulting in attenuating the outer field by an electromagnetic screen: reflection and absorption. The first one is conditioned by eddy electric currents, while the second by absorption of the electromagnetic energy in the bulk of substance and its transition into thermal energy [6]. However to use these effects with the goal of the energy extraction from the inductive storage at nanosecond times of operation seems proves to be inefficient. So the paper proposes to use the effect of the outer field attenuation by screen that is achieved by producing a wave process between the primary winding and screen surface.

The paper also offers a variant of the screen design which makes it possible to transfer the energy to the load in the period of a double path of the electromagnetic wave between the primary winding and screen. Such a screen, even at small diameters of the inductive storage, allows us to transfer the energy to the load, with low loss, by way of the plasma current interrupter, with the energy accumulated for several seconds. The phenomena and processes occurring in the screen during the energy extraction can be explained in terms of the electric circuit of the generator-amplifier which is simpler in design than that proposed in [5]. The combination of the generator-amplifier and the screen proposed enables the ratio $t_d/t_t \sim 10^7$ to be obtained and used to generate terawatt powers.

1 Physics and technology of high power. //Ed. E.P.Velikhov, M.: 1987, 352p.

2 Opening switches //Ed. A.Guenther, M.Mristiansen and T.Martin. PP, NY, 1987, 314p.

3 O.G. Egorov Patent No.2207647, 27.06.2003, Russia.

4 O.G. Egorov // Proc.2nd EAPPC, Vilnius, Lithuania, 2008.

5 O.G. Egorov // Proc.3rd EAPPC, Jejudo, Korea, 2010.

6 Conducting sheaths in the pulse electromagnetic field. / V.V.Vasiliev, L.L.Kolensky,

Yu..A.Medvedev and B.M.Stepanov. M.;"Energoatomizdat, 1982.-200 p.

7 G. Kaden Electromagnetic screens. M.:, GEI, 1957, p.132

SWITCHING OF HIGH-VOLTAGE PULSES WITH SUBNANOSECOND PULSE FRONTS USING AN OPEN DISCHARGE IN A COAXIAL AND PLANAR GEOMETRY

P.P. Gugin, P.A. Bokhan, M. A. Lavrukhin, D. E. Zakrevsky

*A. V. Rzhanov Institute of Semiconductor Physics
Siberian Branch of the RAS, Novosibirsk, Russia, gugin@isp.nsc.ru*

Generation of high-voltage, nanosecond-duration electric pulses following at a high repetition frequency is an important problem in modern electrophysics. The present-day switching devices are only capable of operating either at a low repetition frequency of generated pulses (gas-filled spark gaps) or at a comparatively large pulse rise time constant (hot- or cold-cathode thyatron, etc.). Solid switching devices, such as FETs, IGBTs, or SOS-diodes, are only capable of operating at low working voltages, which circumstance necessitates using intricately designed packs for increasing the operating voltage.

In the present report, we communicate on the results of investigation into the possibility to obtain electric pulses with pulse rise times shorter than 1 ns with the help of an open-discharge (OD) based switcher. Such a discharge burns in a narrow gap, of width 1 to 10 mm depending on the operating voltage, with an extended drift space provided behind the discharge gap. The main feature distinguishing the discharge from other types of discharges is its functioning with resonant emission of radiation from working-gas atoms being the main mechanism underlying the emission of electrons from cathode.

Switching of high-voltage pulses with subnanosecond pulse rise times was examined in discharge cells filled with helium or neon, or in mixtures of the latter gases with hydrogen. The electrode configuration consisted of parallel rectangular planar electrodes. Electric pulses with pulse rise times shorter than 1 ns in helium and in mixtures of helium with hydrogen were obtained. In neon and in Ne-H₂ mixtures, the pulse rise times were in excess of 2 ns. The shortest time (less than 0.5 ns) was obtained in the He and H₂ mixture. Using the dual-pulse method, we showed it possible to reach a pulse repetition frequency more than several tens of kilohertz at switching efficiency over 90%.

The mechanism underlying the fast switching phenomenon is discussed. We demonstrated that the switching duration is defined by the lifetime of the resonant working level (~0.5 ns for He) and by the time required for electrons to drift across the accelerating structure and the drift space. The latter time in

turn depends on the magnitude of the accelerating voltage and on the width of the drift space. The fast switching phenomenon is only observed when the electrons execute an oscillatory motion in the drift-space region. As the result 10-kA 20kV pulses with a pulse-rise time constant less than 1 ns were obtained.

CIRCUIT SIMULATION OF MAGNETICALLY-INSULATED INDUCTION VOLTAGE ADDER

Guo Fan, Zou Wenkang¹, Chen Lin²

Institute of Fluid Physics, Mianyang, China, 394560789@qq.com

¹ *Institute of Fluid Physics, Mianyang, China,
zouwenkang@yahoo.com.cn*

² *Institute of Fluid Physics, Mianyang, China, chenlin_mail@21cn.com*

Circuit simulation of a 10-stage linear transform driver (LTD) which has been already constructed is presented in this paper. This LTD is a magnetically-insulated induction voltage adder and composes 10 identical stages, each of which could give 100kA/100kV pulse on a matched load. To investigate the power flow in the magnetically insulated transmission line, circuit modeling in the frame of telegraph equations including electron leakage has been used. By comparing with experimental results, the method is proved to be reasonable and could be used to analyze the power flow in this LTD facility.

ULTRASHORT VOLTAGE RISE TIME FORMATION BY SEMICONDUCTOR SHARPENERS

**A.I. Gusev, B.G. Slovikovsky, S.K. Lyubutin, S.N. Rukin,
S.N. Tsyranov**

*Institute of Electrophysics UD RAS, Ekaterinburg, Russia,
e-mail: rukin@iep.uran.ru*

High-power ultrafast current switching by Si sharpeners based on a successive breakdown of the series connected structures has been experimentally implemented and theoretically studied. A voltage pulse with a rise time of 300–400 ps was applied to a semiconductor device containing up to 60 series-connected diode structures located in a 50- Ω coaxial transmission line. Due to a sharp nonuniformity of the applied voltage distribution across the length of the device, the structures operate in the successive breakdown mode. Each successive structure breaks down with a shorter time interval as the electromagnetic shockwave builds. In the experiments in a 50- Ω oil-filled transmission lines with an outer diameter of 15 to 30 mm, we have obtained 100- to 150-kV output pulses having a rise time of 60 to 100 ps.

It has been found experimentally that this method of current switching allows forming pulses with a minimum possible rise time, which is restricted in this case by a critical frequency of the TE type wave excitation in the coaxial transmission line.

Besides the experimental data numerical simulation results will be presented and discussed also.

COMPACT HIGH-FREQUENCY SOLID-STATE GENERATOR WITH SUBNANOSECOND VOLTAGE RISE TIME

A.I. Gusev, A.V. Ponomarev, S.N. Rukin

*Institute of Electrophysics UD RAS, Ekaterinburg, Russia,
e-mail: gusev@iep.uran.ru*

A compact high-frequency solid-state generator has been developed and tested. The generator consists of a solid-state SOS-based generator equipped with an output semiconductor sharpener. The SOS generator is used as a

driver for charging a coaxial oil-filled pulse forming line to a voltage level of ~150 kV in about 2 ns. The sharpener presents a stack of series connected semiconductor diodes and forms output pulse with subnanosecond rise time. Across a resistive load of 45 Ohms the generator provides a peak voltage of 70 kV with a rise time of ~0.5 ns and FWHM of 2–3 ns.

The SOS generator is a compact desk-top unit having case dimensions of 63 x 45 x 27 cm³. The semiconductor sharpener is arranged inside the pulse forming line, which has a length of 30 cm and outer diameter of 10 cm. The generator has a remote control unit, which is used for setting a pulse repetition frequency, number of pulses or operation time of the generator. The control unit is connected to the generator via two fiber-optic cables.

The maximum pulse repetition frequency is restricted by a charging time of the primary capacitive store of the generator and attains 10 kHz in a burst mode of operation. The pulse repetition frequency in continuous mode of operation is determined by thermal conditions of the generator components and can be as high as 1 kHz.

Electrical circuit diagrams and principle of the generator operation as well as experimental and testing results obtained will be reported.

A FERROELECTRIC EXPLOSIVE GENERATOR COUPLED TO A COMMON MICROWAVE OVEN MAGNETRON

D. J. Hemmert, J. M. Mankowski¹, L. L. Altgilbers²

HEM Technologies, Lubbock, TX, USA, dhemmert@hemtechnologies.com

¹ *Texas Tech University, Lubbock, TX, USA, john.mankowski@ttu.edu*

² *US Army Space And Missile Defense Command, Huntsville, AL, USA, larry.altgilbers@smdc.army.mil*

HEM Technologies and Texas Tech University investigated the feasibility to power a conventional microwave oven magnetron with a ferroelectric explosive generator (FEG). A 1.2 kW magnetron from a 700 W microwave oven was coupled to the FEG through a power conditioning system to match the FEG output to the magnetron. The FEG output was rectified and voltage limited using a resistor. This produced two negative high voltage pulses into the magnetron. The ferroelectric material was modified in a second set of experiments to directly drive the magnetron without a power conditioning system. The experimental setup and results are discussed.

**A SIMPLE CLADDING TECHNIQUE FOR
CONSTRUCTING FAST CVD**

A Prototype 50 kV/ 2.5 GHz/ 70 dB/ 5 ns/ 50 Ω Loaded CVD

K. Hojatzadeh

*Electronic & Communication Research Center, Tehran, IRAN,
KarimHojatzadeh@gmail.com*

Many pulsed power experiments often necessitate the accurate measurement of high transient voltages with very short rise times. Capacitive Voltage Divider (CVD) is an accurate and reliable voltage measurement technique in ultra wideband systems. The ultimate goal in capacitive voltage monitoring is a simple design, with good high frequency response, convenient attenuation ratio and longtime constant measurement capability. Design and construction of a self-integration CVD with flat frequency response, enough attenuation ratio and time window is extremely valuable for use in capturing sub nanosecond pulses. We propose a new and simple design for CVDs with flat frequency response up to 2.5 GHz, having enough division ratios more than 70 dB and integration times greater than 5 ns. Also it is capable of handling 50 kV transient pulses through the RG-218 Cable in 50 Ω loading. Due to their simple and low-cost construction structure they can be widely used and scaled in many sub nanosecond application. The simulation of the CVD with full wave FDTD codes and commercial circuit analysis programs shows good agreement with the experimental results.

UWB PULSE COMPRESSORS BASED ON THE OVERVOLTING CHARGE TECHNIQUE

K. Hojatzadeh

*Electronic & Communication Research Center, Tehran, IRAN,
KarimHojatzadeh@gmail.com*

Recently, pulse compressing technique is widely used as a stable technique in generation of UWB pulses. The main requirement of any high voltage compact pulsers is fast charging of pulse forming lines and incorporated gaps. In sub nanosecond regime the fast charging plays an important role in providing an overvolting conditions for gaps to withstand voltages, two or three times greater than their DC breakdown voltage. This overvolting process makes the gaps to break down in sub nanosecond delay time and generates fast transient leading or falling edges for the output pulse. This fast charging and overvolting technique affect the resistive portion of rise time regarding the greater electric field generated at the gap region. Also, the overvolting technique lets us to keep the gaps close to each other even less than 1 mm or 1 nH to decrease the inductive portion of generated rise time. We describe a technique for fast charging purpose based on transmission line to transmission technique which is capable of overvolting the lines and gaps. The performance of the technique based on the delay time and characteristic impedance of charging and load lines are verified by circuit simulation and experimental results. The effect of each parameter on the shape of output pulse is presented. Finally, the performance of a pulse compressor based on overvolted line and gaps extracted from the view point of energy transfer and efficiency in both simulation and experiments.

QUASI-LINEAR MODE OF HIGH POWER GAAS PCSSS

**Hongwei Liu, Jianqiang Yuan, Jinfeng Liu, Hongtao Li,
Weiping Xie**

*Institute of Fluid Physics of CAEP, Mianyang, China,
lhw1982@tom.com*

The photocurrent waveform from the semi-insulating GaAs Photoconductive semiconductor switch (PCSS) when using different trigger laser energy and electric field has been tested. The peak value of current is in direct proportion to the work voltage at higher laser energy and lower storage ca-

pacitor. The results were discussed from the generating and recombination process of the carrier and a special quasi-linear mode of high power GaAs PCSSs was mentioned. At this mode a long lifetime can be achieved at high voltage and current. The test shows more than 1000 times lifetime using a single PCSS with electrode gap of 10 mm under a bias of 26 kV, current of 4.3 kA, full-width at half-maximum of 6 ns and repetition of 5 Hz excited by a laser pulse with the energy of less than 1 mJ.

A SQUARE VOLTAGE PULSE FORMER WITH A PEAK VALUE UP TO 500 KV AND 200 NS DURATION

B.A. Kablambaev, N.A.Ratakhin

*Institute of High Current Electronics
Siberian Branch of Russian Academy of Sciences, Tomsk, Russia*

A small-sized square high voltage pulse former is developed. The peak voltage on the matched load 45 ohm is 450÷500 kV, pulse duration at half maximum is about 200 ns, front is 20÷25ns, and non-uniformity of flat top is about 10%.

The former produces voltage pulses by combination of electric waves in the lines with distributed parameters. This method is widely used for generation of high voltage pulses in double forming lines (DFL). In contrast to DFL, four forming lines were used in the designed former, this makes it possible to generate a 450 kV voltage pulse with on the matched load with a charge voltage of 230 kV. Spiral lines with glycerine insulation were used to form a pulse of 200 ns in duration.

The construction of the former allowed us to increase a density of storage energy twice in comparison with the former based on single or double forming lines.

PULSED GENERATORS FOR DYNAMIC FRAGMENTATION OF ROCKS

**A.V. Kharlov, B.M. Kovalchuk, E.V. Kumpyak,
V.A. Sinebryukhov V.N. Kiselev**

*Institute of High Current Electronics, Tomsk, 634055, Russia,
akharlov@lef.hcei.tsc.ru*

A high-voltage pulse technology is one of effective techniques for disintegration and milling of rocks, separation of ores and synthesized materials, recycling of building and elastoplastic materials. We present here design of two portable HV pulsed generators, designed for materials fragmentation, though another technological applications are possible as well.

Generator №1 consists of power supply (2 kV, 8 kJ/s) low voltage block, high voltage transformer, high voltage capacitive storage block, two electrode gas switch, fragmentation chamber and control system block. Low voltage block incorporates storage capacitor bank C1 with 600 μ F capacitance, demagnetization block, and thyristor switch. Maximum charging voltage is +2 kV, stored energy up to 1200 J. Maximum amplitude of current pulse from the low voltage block is ~ 15 kA with pulse duration ~ 120 mks. High voltage capacitive storage block incorporates the following parts: HV capacitive storage, capacitive voltage divider, charging inductor, gas switch and fragmentation chamber. HV capacitive storage is mounted in a metal tank, filled with transformer oil. High voltage capacitive storage C2 is assembled from ceramic disk TDK HV capacitors. High voltage transformer is mounted in separate metal tank, also filled with transformer oil. Output parameters of the generator (voltage amplitude, frequency, number of pulses in a burst) set up through the control system computer. Technical characteristics of the pulsed generator: stored energy in HV capacitors can be varied from 50 to 1000 J, – output voltage up to 300 kV, voltage rise time ~ 50 ns, typical operation regime – 1000 pulses bursts with a repetitive rate up to 10 Hz. The fragmentation process can be controlled within a wide range of parameters.

Generator №2 is made on Marx scheme with 8 stages, each stage of the generator (C1-C8) consists of two connected in parallel IK-100-0.4 capacitors. Two electrode spark gap switches, filled with air, are used in the generator. Self breakdown voltage of the gaps is adjusted by change of air pressure in the switches. All eight switches are mounted in one body that is made from fiberglass tube (\varnothing 130 mm). Capacitors of the stages and switch block are mounted in the container, filled with transformer oil. The stages are charged

from a power supply of negative polarity voltage (50 kV, 8 kJ/s) to - 25÷50 kV. Parameters of the generator: stored energy in capacitors 2÷8 kJ, amplitude of the output voltage 200÷400 kV, voltage rise time on a load 50÷100 ns, repetitive rate 0.25 Hz. The output voltage level, operation frequency and total number of pulses are set from the control block.

This report presents detailed design of two generators, description of operation regimes and test results.

PULSE SHAPING IN SQUARE PULSE LTD

A. A. Kim^{1,2}, V.A. Sinebryukhov¹, S.N. Volkov¹, S.S. Kondratiev¹, V.M. Alexeenko¹, F. Bayol³, G. Demol³

¹*Institute of High Current Electronics, Tomsk, Russia, kim@oit.hcei.tsc.ru*

²*Tomsk Polytechnic University, Tomsk, Russia, aakim@tpu.ru*

³*International Technologies for High Pulsed Power, Thegra, France, gdemol@ithpp-alcen.fr*

The usual LTD architecture provides sine shaped output pulses that may not be well suited for some applications like z-pinch drivers, flash radiography, high power microwaves, etc. A more suitable power pulse would have a flat or trapezoidal (rising or falling) top.

LTD with such shape output pulse can be produced by including within its circular array a number of third harmonic (modified) bricks in addition to the main (standard) bricks. Such LTD called Square Pulse LTD was produced and successfully tested recently [1].

In these tests it was demonstrated that the shape of the pulse top might be controlled by varying the inductance of the output strip lines connecting the bricks with the cavity output. At the same time, such type of pulse shaping was found to be rather complicated as well as limited by the design of these strip lines. Much better results in pulse shaping were obtained by varying the value of the trigger resistors in the standard and/or modified bricks. The value of these resistors determines the delay between the time the trigger pulse appears at the output of the trigger cable and the time the switches fire. Then different trigger resistors in the standard and modified bricks result in phase shift between the currents delivered by these bricks into the load thus allowing to control the shape of the pulse top from rising to flat or falling.

In the report we present simulation and test results supporting the pulse shaping mechanism described above.

1 A. A. Kim *et al*, Phys.Rev. ST Accel.Beams **15**, 040401 (2012).

A TERAWATT-LEVEL POWER AMPLIFIER WITH A LOAD CURRENT MULTIPLIER LOCATED UPSTREAM OF THE POS ¹

**V. A. Kokshenev, F. I. Fursov, N. E. Kurmaev, A. Yu. Labetsky,
A. P. Semenov, A. V. Shishlov**

*Institute of High Current Electronics SB RAS, Tomsk, Russia,
e-mail: vak@oit.hcei.tsc.ru*

A power amplifier consisting of a plasma opening switch (POS) and a load current multiplier (LCM) that was connected to the inductive storage circuit in the region of a sharp change in the POS magnetic field profile has been tested on the GIT-12 generator. The connection of the load circuit at the instant of the POS impedance fast growth has been achieved without a prepulse current during the whole POS conductivity stage. At a generator current of 4.1 MA with a current rise time of 1.2 mcs, the current switched to an inductive load had an amplitude of 4.3 MA and a current rise time of 300 ns. Modification of the transition region between the plasma opening switch and the load using a T-joint made it possible to implement an operation regime with the load circuit connected upstream of the plasma opening switch without using a separating spark-gap. It was shown that the proposed design of the generator structure allowed preventing of the LCM input shunting by the beam-plasma flows from the plasma opening switch region.

¹The work was supported by RFBR Grant No. 12-08-00575

PHASE FIXATION OF POWER NANOSECOND GUNN OSCILLATORS

V. Y. Konev, A. I. Klimov

*Institute of High Current Electronics SB RAS, 2/3 Akademicheskoy Ave.,
Tomsk, 634055, Russia, honour@vtomske.ru*

Measurement results of X-band nanosecond Gunn oscillators phase unstability with pulse width no less than 20 ns are represented. Possibility of two nanosecond Gunn oscillators power addition and fixation phase for the cases when Gunn diodes are connected serially and parallel inside the resonator is shown. Current-voltage characteristics of Gunn diodes located in the strong electromagnetic field are plotted.

NANOSECOND PULSED POWER GENERATOR FOR SELECTIVE DISINTEGRATION OF MINERAL QUARTZ

E. G. Krastelev, V. V. Stepnov

Quartz company LLC., Moscow, Russia, ekrastelev@yandex.ru

Pulsed power generator is designed for technological application in production of fine grains of mineral quartz and it also may be used for selective fragmentation of other nonconductive minerals. The main parameters of the generator are the next: amplitude of the output voltage – up to 500 kV, output impedance is about 15 Ohm, duration of a half of period of a discharge current – 70-90 ns, current amplitude – up to 30 kA. The design of the generator provides its continuous operation in a pulse-periodical mode with a pulse repetition rate from 10 pps up to 50 pps.

The generator consists of a primary low voltage capacitive storage, step-up pulsed transformer, high voltage oil insulated coaxial capacitor and an output gas switch followed by discharge chamber.

The low voltage capacitor bank is assembled of 8 pairs of bipolar charged up to ± 500 V capacitors 75 μ F each switched by 8 thyristors. The maximum stored energy is 150 J. Electro-mechanical frequency converter (motor-alternator) 50 to 400 Hz is used as a charging voltage source for both the fast charging (2,5 ms) of the capacitor bank and the preventing a pulse

loading of the power supply line. All elements of the low voltage circuit are assembled in a commercially available electro-technical box with sizes 800x420x1950 mm³ (WxDxH).

The step-up pulse transformer and the HV coaxial capacitor are located inside of cylindrical tank about 1m in diameter and about 2,5 m in height installed vertically and filled by transformer oil. The output gas switch and a discharge chamber are installed at the top of the tank. The output pulse from the low voltage module with amplitude up to 1 kV is applied to the primary winding of the pulse transformer by set of 8 quasi-coaxial cables of 6 m long connecting two modules of the generator. Iron core pulse transformer with foil spiral windings has transformation coefficient of 500 and coupling coefficient about 0,98. The charging time of the HV capacitor is about 45μs. The output switch operates in a self-breakdown mode in a pressurized to 2,5÷3 atm circulating N₂. A new design of the switch provides a stable operation at levels close to the peak capacitor voltage.

Three generators were constructed during the 2006-2008. Since that they are in routine operation being parts of technological lines for pure quartz production. The number of accumulated pulses up to now is far beyond of 10⁸. All this time the generators had been working without replacement of any parts except elements of discharge chambers.

HIGH-VOLTAGE SPARK GAP SWITCH WITH SUBNANOSECOND RISE TIME

I.K.Kurkan, N.M. Bykov, A.V. Gunin, V.V. Rostov

Institute of High Current Electronics, Russia, ikk@lfe.hcei.tsc.ru

The method of a subnanosecond front forming of megavolt level voltage pulse was proposed and researched with computer simulations and in real experiments both. Rising edge was formed by two sequentially placed spark gap switches divided by short line with the low-impedance comparing to the forming line of high voltage generator. This design allows to utilize energy of back wave from the second switch for a main pulse formation. It prevents a high voltage generator from overvoltage damages also. The distinctive feature of this method is an opportunity to form an overshoot with a voltage level of the main pulse.

Experiments was carried out on high voltage generators of SINUS series with a matched dummy load at pulse repetition rate up to 100 p.p.s. Forming line voltage was varied from 400 to 800 kV. Pulse duration was about 20 ns. Nitrogen under pressure of 10-15 atm was used in spark gap switches. Possibility of a high voltage pulse formation with the rising edge of about 0.5 ns was demonstrated.

Computer simulations were performed with using of KARAT code and PSpice. Simulation results are in good agreement with experimental ones.

AN UNTRIGGERED GAS PULSE SWITCH WITH IMPROVED OPERATION (ACTUATION) STABILITY

A.V. Lavrinovich, A.A Kachalkov

*Institute of High Current Electronics
Siberian Branch of Russian Academy of Sciences
Tomsk, Russia, Shljakhtun_s@ovpe.hcei.tsc.ru*

The results of investigation of pulsed breakdown research results in untriggered two-electrode and three-electrode gas switches are described. Different shapes of ground and high-voltage electrodes are tested. The switches are filled with air at different pressure. For the three-electrode switch operating at the voltage rise rate $(2 \cdot 10^{11} - 3 \cdot 10^{11})$ V/s, voltage 20-25 kV and air pressure ≥ 5 atm the operating time delay jitter is found to be less the 3 ns. The switch is used to time different devices to the output pulse of the high current accelerator with water forming lines.

**EXPERIMENTAL INVESTIGATION ON ELECTRODE EROSION
AND INSULATION RECOVERY OF HIGH CURRENT GAS
SPARK GAP**

Liu Yu, Chen Lin¹, Zhou Liangji², Zou Wenkang, Dai Yingmin

*Institute of Fluid Physics, CAEP, Sichuan, China,
liuyu2011caep@gmail.com*

¹ *Institute of Fluid Physics, CAEP, Sichuan, China,
chenlin_mail@21cn.com*

² *Institute of Fluid Physics, CAEP, Sichuan, China,
zljcaep@163.com*

Switch is one of the most important parts of pulsed power device, whose performance directly decide the device output parameters. Therefore, superior capability switch becomes a key factor to manufacture high property driver.

To investigate the lifetime of gas spark gaps, the experiments of electrode erosion and gas flow were carried out under high current pulse. In the report, we describe the test results of the mass lose rate of 4 kind electrodes materials. And under dynamic condition which means gas flow, gas between the electrodes allows a significant improvement in the switch recovery.

**CONCEPTUAL DESIGN OF A NEW MICROSECOND LTD
STAGE FOR AN UPGRADE OF THE SPHINX Z-PINCH DRIVER**

A. Luyen, F. Lassalle, B.Roques, T.Chanconie, F.Bayol¹

CEA, DAM, GRAMAT, F-46500 Gramat, France

¹ *Int. Technologies for High Pulsed Power, Thegra, France*

The SPHINX machine [1] developed at CEA Gramat is the first Z-pinch driver based on LTD technology and is used since 2006 for radiation effects experiments.

SPHINX uses 160 microsecond LTD stages (16 branches, 10stages in series per branch). A single stage stores 14.4 kJ and can deliver a 560kA, 30kV, 270ns (10%-90% rise time) pulse in a matched load ($R_{load} = 0.054\Omega$). This stage consists of 2 parallel bricks with for each brick a 4 μ F storage ca-

capacitor charged to 60kV and a 7 gaps 18 channels spark switch. Switches operates in dry air at atmospheric pressure and solid dielectrics are used for insulation inside the cavity (no oil or purified gases are required). Size of this stage is 2.3m*0.46m with 0.43m thickness.

Several driver designs, based on microsecond or sub-microsecond LTD technologies are investigated to improve the SPHINX machine performances. We present here a prototype designed to analyse the microsecond option.

This prototype will store 200 kJ and simulations give a 5MA, 40kV, 360ns (10%-90% rise time) pulse on a matched load ($R_{load} = 0.008\Omega$). Stage consists on 16 parallel bricks with for each brick a 4 μ F capacitor charged to 80kV and a multi-gap multi-channel (MMCS) spark switch. Like a SPHINX LTD stage, this prototype can operate with dry air at atmospheric pressure and needs no oil and no pressurized switches. Magnetic core is designed to withstand a 70 mV.s integral and the output vacuum line is 1.4m outer diameter. Size of this LTD stage is 3.9m*3.9m with 0.46m thickness.

Design and electrical simulation from this microsecond LTD prototype are presented. Details are given on design and experimental tests of a single switch.

1 F. Lassalle et al., IEEE Trans. On Plasma Sciences, Volume 36, Issue 2, Part 1, pages 370-377, April 2008

LTD EFFICIENCY FOR Z-PINCH LOADS

V.I. Oreshkin¹, A. A. Kim^{1,2}, L. G. Glazov¹

¹*Institute of High Current Electronics, Tomsk, Russia, oreshkin@ovpe.hcei.tsc.ru*

²*Tomsk Polytechnic University, Tomsk, Russia, aakim@tpu.ru*

One of the main goals of the modern high-power accelerators is the production of high energy soft x-ray pulses in z-pinch layout for inertial fusion energy. To the moment, most powerful accelerators created for this purpose are build by using the mature Marx/water line technology. There exist many papers describing the physics of the x-ray production in z-pinches, and the requirements to the Marx/water line generators allowing to maximize the efficiency of this process.

At the same time, LTD-based accelerators promise ~1.6 times higher total radiated x-ray energy than similar size Marx/water line generators [1].

In the report we investigate what are the requirements to the LTD-based accelerators providing maximum efficiency of energy transfer into the z-pinch kinetic energy.

1 W.A. Stygar *et al*, Phys. Rev. ST Accel. Beams **10**, 030401 (2007).

HARD X-RAY SOURCES BASED ON OF HIGH-CURRENT ACCELERATORS

V.K. Petin, A.A. Chertov, S.V. Shljakhtun

*Institute of High Current Electronics
Siberian Branch of Russian Academy of Sciences
Tomsk, Russia, Shljakhtun_s@ovpe.hcei.tsc.ru*

A number of hard X-ray sources based on high current pinch diodes are described. Parameters of the sources are varied in a wide range: an irradiated area - from a few to hundreds of cm²; radiation pulse duration at half maximum (FWHM) – tens of ns; radiation flux – from a few to tens of J/cm² depending on the irradiated area. The diode designs optimal for hard X-ray output are described. The experimental spatial distribution of radiation is compared with the theoretical calculations. The calculations were performed using sources with different angle and area radiation intensity distribution.

HIGH FREQUENCY GENERATOR BASED ON THE SHOCK-EXCITED OSCILLATOR CIRCUIT

A. V. Ponomarev, D. A. Lipchak

*Institute of Electrophysics, Ural Branch, Russian Academy of Sciences,
Ekaterinburg, Russia, e-mail: apon@iep.uran.ru*

The decaying oscillation pulses solid-state generator based on the shock-excited circuit and magnetic compression stage has been developed for the corona discharge applications.

Output harmonic voltage oscillations frequency reaches a few MHz by the circuit parameters adjustment while the pulse repetition rate is up to 1 kHz. The time decay constant depends on the load and could be varied from 5 to 15 μ s.

Estimations of the generator efficiency are not less than 50 percent, shown in this paper.

OPERATION OF A SEMICONDUCTOR OPENING SWITCH AT ULTRAHIGH CURRENT DENSITIES

S.N. Rukin, S.K. Lyubutin, B.G. Slovikovsky, S.N. Tsyranov

*Institute of Electrophysics UD RAS, Ekaterinburg, Russia,
e-mail: rukin@iep.uran.ru*

The operation of a semiconductor opening switch (SOS diode) at current densities of tens of kA/cm^2 is studied. In experiments, the maximum reverse current density reached 40–80 kA/cm^2 for 40–60 ns. Experimental data on SOS diodes with a structure of p^+p-n-n^+ type having a $p-n$ junction depth of 145 to 180 μm are presented. The processes of electron-hole plasma dynamics in the diode at pumping and current cutoff stages is studied by numerical simulation methods. It is shown that current cutoff process is associated with the high electric field region formation in a thin ($\sim 45 \mu\text{m}$) layer of the highly doped p -region of the structure, where the acceptor concentration exceeds 10^{16}cm^{-3} , and the current cutoff process depends weakly on the $p-n$ junction depth.

Experimental data and numerical simulation results will be presented and discussed.

**SOLID STATE HIGH-POWER GENERATOR BASED ON
DOUBLE FORMING LINE AND SEMICONDUCTOR OPENING
SWITCH**

**S.N. Rukin, A.I. Gusev, M.S. Pedos, A.V. Ponomarev,
S.P. Timoshenkov, S.N. Tsyanov**

*Institute of Electrophysics UD RAS, Ekaterinburg, Russia,
e-mail: rukin@iep.uran.ru*

New circuit for Semiconductor Opening Switch (SOS) pumping has been proposed and realized. The circuit presents an oil-filled Double Forming Line (DFL) equipped with an output ferrite magnetic switch. Each line has a wave impedance of 19 Ohms, a total energy content is around 50 J at a charging voltage of ~500 kV. During charging process the DFL and magnetic switch insure a forward pumping of the SOS for ~40 ns with a peak current of 3 to 4 kA. After output magnetic switch saturation the DFL is discharged through the SOS in reverse direction providing the reverse pumping for the SOS. The reverse current via the SOS is increased up to 12 kA during 8 to 12 ns. When the reverse current attains its maximum value the SOS cuts off the current in less than 2 ns. Maximum current cutoff rate reaches $6 \cdot 10^{12}$ A/s.

A coaxial oil-filled Transmission Line (TL) is used as a load for the generator. At TL wave impedance in the range of 50 to 75 Ohms a voltage pulse has a peak value of 480–570 kV that corresponds to a peak power of 4 to 5 GW. Rise time of the output pulse is around 2.5 ns, and FWHM is 5 to 6 ns.

Design of the generator and experimental data obtained will be presented. Experiments on the shortening the rise time of the pulse by a ferrite and semiconductor sharpeners installed in the TL will be reported also.

THE VISUALIZATION AND ASSESSMENT OF THE PULSED ELECTRON BEAM CURRENT DENSITY DISTRIBUTION

S.V. Scherbinin, M.E. Balezin, S.Yu. Sokovnin, A.E. Surovtzev

*Institute of Electrophysics UD RAS, Ekaterinburg, Russia,
scher@iep.uran.ru*

In technology applications of pulsed repetitive electron accelerators much attention is paid to improve the uniformity of the electron beam current density distribution that determines the correct irradiation of the objects. For the repetitive nanosecond electron accelerator URT-0,5 the sensor for visualization and assessment of the pulsed electron beam distribution has been developed. In this paper the operational principle of the sensor is considered. Experimental results of the visualization are presented. The approximate calculations of the pulsed electron beam current density distribution are discussed.

INCREASING STABILITY OF HIGH-VOLTAGE SUBNANOSECOND PULSE PARAMETERS

**K.A.Sharypov, M.R.Ulmaskulov, V.G.Shpak, S.A.Shunailov,
M.I.Yalandin**

*Institute of Electrophysics, UB RAS, 106, Amundsen Str., 620016,
Ekaterinburg, Russia, const@iep.uran.ru*

The research results of increasing stability of amplitude and time subnanosecond pulse parameters are presented. Subnanosecond pulses are formed by means of initial pulse shape converter of nanosecond generator based on compression schemes. The aim was increasing stability and form repeatability of subnanosecond pulses with repetition rate up to 25 pps for burst of 50, 100 or 250 pulses.

Achievement of the aim was realized by solving tasks in several directions. It was provided by means of optimization of scheme solution of a compression energy device which formed subnanosecond pulse by form conversion of nanosecond pulse with peak power increasing, and by design improvements of convertor units. In addition the ferrite lines were used as both

a unit of convertor and a separated additional device to sharpen the pulse rise time of the driver.

As a result of using a ferrite line in the capacity of scheme while in uni-directional pulse forming with pulse duration ~ 0.4 ns (FWHM) the peak voltage amplitude was increased by 6.5% up to -275 kV at matched load 50 Ohm when repetition rate 25 pps. The well repeatability of bipolar pulse with peak-to-peak duration ~ 0.5 ns and standard deviation ~ 50 -60 ps at frequency 25 pps was reached, when bipolar pulse forming with average peak-to-peak voltage amplitude ~ 350 -375 kV and scattering of voltage amplitude of initial pulse of $\sim 10\%$. Application of ferrite line as an additional device for sharpening the edge of initial nanosecond pulse provides well repeatability of pulse shape in burst operation mode (250 pulses).

HIGH-VOLTAGE LOW-DISTORTION REFLECTOMETR BASED ON TWO VOLTAGE DIVIDERS WITH COUPLED LINES

**K. A. Sharypov, S. A. Shunailov, V. G. Shpak, M. R. Ulmasculov,
M. I. Yalandin**

*Institute of Electrophysics UB RAS, 620016,106, Amundsen Str.,
Ekaterinburg, Russia, const@iep.uran.ru*

For the researches of picoseconds dynamics of resistive characteristics of the loads (gas discharge gaps; vacuum diodes) supplied with a short high-voltage pulses or subnanosecond voltage steps, it is problematic an absolute time reference of the voltage and current signals just at the load. Independent voltage and current sensors don't solve the problem as they are separated in space, and delay between their signals can't be calibrated as the load is open initially. In these conditions, a time-domain reflectometry (TDR) of traveling voltage/current signal is an adequate way of measurements. For the pulses amplitudes of hundreds of kilovolts and demanded picoseconds resolution, a TDR of a voltage pulse is preferable. As well as in low-voltage TDR, the reflected signal bears information about resistive properties of the load. Either a time isolation of the transmitted and reflected pulses, if they are short, or a regular or a-priori known form of travelling pulse are necessary for discrimination of the reflected pulse from traveling one. In any case there should be no parasitic reflections in the duct between sensor and load. The pulses of high-voltage generators are usually accompanied by the tightened noise sig-

nal. If so, then extraction of pure reflected signal against the tail background of transmitted pulse can be attained by the use of two identical voltage sensors registering the signals with a time shift. In the design of high-voltage reflectometer we use two capacitor dividers on the coaxial coupled lines shifted along transmitting duct. Dielectric constants of isolation in high-voltage and measuring sections are equalized. Wave impedance mismatch of the duct in a zone of the dividers position doesn't exceed 1.5 %. The manufacturing technology provides identity of the division factors not worse than 4 %. The travelling voltage front of duration above 200 ps (on the level "0.1-0.9") is registered without visible distortions. Examples of reflectometric measurement of the rate of an atmospheric discharge gap closing are presented.

Work is executed with support of the researches program of the RAS Presidium «Fundamental problems of pulsed high-current electronics» and RFBR grant 11-08-00189.

HIGH-VOLTAGE FERRITE SHARPENING LINE WITH CONTROLLED DELAY TIME

**K.A.Sharypov¹, M.R.Ulmaskulov¹, V.G.Shpak¹, S.A.Shunailov¹,
M.I.Yalandin¹, V.V.Rostov², S.N.Rukin¹**

¹*Institute of Electrophysics, UB RAS, 106, Amundsen Str., 620016, Ekaterinburg, Russia, const@iep.uran.ru*

²*High Current Electronics Institute, SB RAS, 2/3 Akademicheskii avenue, 634055, Tomsk, Russia*

The sharpening of nanosecond edge (~1.5 ns) of RADAN-303 (- 150-170 kV) high-voltage pulse to subnanosecond level was investigated with the aid of coaxial saturated ferrite line. To get rise time not longer than ~ 300 ps (0.1-0.9) and guarantee a possibility of precision time delay adjustment was the task. It was the key question in the experiments on phase synchronization of two - channel high power microwave generators based on relativistic Ka-band BWO without electrodynamic connection.

Lines were optimized along the length and to the cross-section of active region (to sizes of ferrite rings), and to the type of ferrite material. Magnetization by external solenoid was limited to the mode, when high-frequency modulation after the pulse front was not expressed. The solenoids of two

channels were connected in series with stabilize DC source to provide the identity of the sharpening conditions. It was a possibility of precision and independent variation of magnetization currents by solenoids parallel shunting. The delay control sensitivity composed 0.1 ps/mA. The DC source and solenoid windings temperature drift ensured the practical accuracy of adjustment with the value not worse than 0.5 ps.

The high-current semiconductor diodes were tested in combination with the ferrite line to obtain the shorter rise time. Basic results of such ferrite lines application are given in the experiment, where coherent power summing of two relativistic Ka-band BWO and radiation pattern control was demonstrated.

Studies were conducted within the integrated project of IEP and HCEI in accordance with the program of RAS Presidium “Fundamental problems of pulsed high-current electronics”, and also, with the support of Russian Basic Research Fund, grants: 11-02-00097a, 11-08-00176a and 12-08-00476a.

A COMBINED SHARPENING-CHOPPING SWITCH WITH OPERATING VOLTAGE ABOUT 1 MV

S.V. Shljakhtun, A.A Kachalkov, A.V. Lavrinovich, V.K. Petin

*Institute of High Current Electronics
Siberian Branch of Russian Academy of Sciences
Tomsk, Russia, Shljakhtun_s@ovpe.hcei.tsc.ru*

A combined sharpening-chopping switch design is described. The switch is tested at a load of hundreds of ohm to form a voltage pulse with the operating value of about 1 MV and the pulse duration varied within 50 – 200 ns. The proposed design provides for two gaps filled with a sulfur hexafluoride – nitrogen mixture at a pressure of up to 16 gage atm to be located in a single housing.

The untriggered sharpening gap provides a pulse rise time of 8-10 ns and the triggered gap ensures the same (8-10ns) time for the pulse trailing edge. The operating time of the chopper and the resulting pulse duration are determined to an accuracy of 5 ns by the length of a cable transmitting the driving pulse to the gap.

**LTD DESIGN BASED ON PARAMETERS OF
AVAILABLE SWITCHES**

K. W. Struve, M. G. Mazarakis, and M. E. Savage

Sandia National Laboratories, Albuquerque, NM, USA,
kwstruv@sandia.gov*

We propose an alternative approach to designing an LTD. When the first LTDs were built the design was optimized around the size of available capacitors. The mechanical dimensions and switch were chosen to match the available capacitance and inductance parameters. That led to a design that requires a switch that conducts 25 kA for a few hundred nanoseconds, and holds off a DC voltage of 200 kV. When we look for switches that can be reliable for hundred's of thousands of shots we naturally ask if there is a semi-conductor switch that can do the job. There are no semi-conductor switches with parameters even close to these requirements, which are now being met with high-pressure spark gaps. So, alternatively, we suggest looking at an LTD design that uses available semi-conductor switch parameters, and determine what these mean for design of the LTD brick and cavity. This approach leads to designs with many more cavities and more bricks in each cavity with smaller capacitors. Base on this approach we will present a design of a 6-MV LTD module using existing semi-conductor switch technology than can deliver 1 MA with a 100 ns rise-time. Note that this approach is an extension of work previously done by Cook, Kirbie, and Jiang.

*Sandia National Laboratories is a multi-program laboratory managed and operated by Sandia Corporation, a wholly owned subsidiary of Lockheed Martin Corporation, for the U.S. Department of Energy's National Nuclear Security Administration under contract DE-AC04-94AL85000.

**NANOSECOND-PULSE SURFACE DIELECTRIC BARRIER
DISCHARGE IN OPEN AIR**

**Tao Shao¹, Hui Jiang¹, Cheng Zhang¹, Xueke Che²,
Wenfeng Li¹, Ping Yan¹**

¹ *Institute of Electrical Engineering, Chinese Academy of Sciences, Beijing, China* st@mail.iee.ac.cn

² *Academy of Equipment, Beijing, China*

Surface Dielectric barrier discharge excited by high voltage pulses is a promising approach for producing plasma in airflow control fields. A magnetic compression solid-state pulse generator is used to produce repetitive nanosecond pulses for the excitation of surface DBD. Output positive pulse of the generator has a rise time of about 50 ns and a full width at half maximum of 80 ns. This paper illustrates the electrical characteristics of surface DBD excited by repetitive unipolar nanosecond-pulses in atmospheric air, especially, the discharge energy and power consumption are described. The experimental results show that that nanosecond-pulse surface DBD is a filamentary discharge. Discharge takes place during the rising time of the applied voltage pulse. Discharge current mainly includes two parts of pulse, and the two parts of pulse have a certain intrinsic relationship with the uniformity of the filament distribution. Voltage amplitude is an important factor to the discharge uniformity and the length of plasma. Electrode width and gap have little influence on discharge current and plasma strength.

This work was supported by opening project of State Key Laboratory of Electrical Insulation and Power Equipment in Xi'an Jiaotong University under Grant EIPE12204.

INSULATOR SUPPORT OF COAXIAL MAGNETICALLY-INSULATED TRANSMISSION LINE

Zhang Le, Wei Bing¹, Zou Wenkang²

CAEP, Mianyang, China, phypku@qq.com

¹*CAEP, Mianyang, China, 73wb@163.com*

²*CAEP, Mianyang, China, zouwenkang@tsinghua.org.cn*

Both theoretical and experimental study of Magnetically Insulated Transmission Line (MITL) have become more and more noticeably, because of the rapid development of pulsed power technology and fast Z-pinch technology. MITLs can transfer power density beyond TW/cm^2 , which is miraculous in high power pulsed technology. So the applications of MITL are very extensive.

But because of the metallic cathode's gravity, inner cylinder deviates from axis in the long MITL, which would bring about the loss of current transmission efficiency. In order to prevent this situation from happening, we attempted hanging an insulator between anode and cathode tubes. Both theoretical education and Pspice simulation showed that there is little but far less than big loss in current transmission efficiency. In order to compare with the insulator support situation we also have taken straight tube experiment under the same condition. The experiment's results also proved the feasibility of the support of inner cylinder by insulator.

GENERATION OF A FOCUSED ELECTRON BEAM IN A PLASMA-FILLED DIODE

A.A. Zherlitsyn, B.M. Kovalchuk, N.N. Pedin

*Institute of High Current Electronics, 2/3, Akademichesky av., 634055
Tomsk, Russia*

An electron source based on the plasma-filled diode and the air-insulated pulsed linear transformer has been realized. An electron beam with the energy of ≥ 1 MeV and peak power of ≥ 100 GW has been obtained. The energy of ≈ 5 kJ is dissipated in the diode; the efficiency of the energy transfer from the primary capacitive storage into the diode exceeds 60%. The di-

ameter of high-energy electron beam is ≈ 10 mm. Application of the plasma-filled diode allowed raising the output voltage by ≥ 2.5 times, the peak power by ≥ 5 times in comparison with the vacuum diode results.

A COMPACT AIR INSULATED GENERATOR FOR e-BEAM DIODE

A.A. Zherlitsyn, B.M. Kovalchuk, N.N. Pedin

*Institute of High Current Electronics, 2/3, Akademichesky av., 634055
Tomsk, Russia*

The paper presents the design and test results of a compact (the overall dimensions are $0.35 \times 0.7 \times 1.2$ m³) based on the air-insulated capacitor units. The generator is intended for studies in the field of creation of low-impedance electron accelerators (wave impedance of 1–10 Ohm) and it can be used as well to solve applied problems. The generator stores up to 800 J of energy and delivers into the active load with steady impedance $\approx 75\%$ of stored energy in ≈ 300 ns. The output voltage amplitude is ≈ 50 kV at the load of ≈ 1 Ohm. Generator testing at the operation to the electron diode with the multipoint and plasma cathodes has been carried out in the residual gas pressure ranging from $5 \cdot 10^{-4}$ to $5 \cdot 10^{-3}$ torr. An electron beam with the energy of ≈ 200 J at the energy transmission efficiency exceeding 40% has been obtained.

PLASMA-FILLED DIODE WITH USING LASER PRODUCED PLASMA

A.A. Zherlitsyn, B.M. Kovalchuk, V.M. Orlovskii, N.N. Pedin

*Institute of High Current Electronics, 2/3, Akademichesky av., 634055
Tomsk, Russia*

The paper presents the results of research of an electron diode with the accelerating gap preliminary filled with laser ablation plasma. The plasma is generated as a result of exposure on a solid-state target by laser radiation with

the wavelength of 10.6 μm and energy in the pulse up to 0.75 J. The obtained plasma provides a low-resistance discharge in the diode gap (the resistance is much less than the wave impedance of the supply generator) with the current of ≈ 50 kA at the current rise time of ≈ 150 ns. The subsequent transition of the diode into the high-resistance phase is accompanied by generation of an electron beam of the power exceeding 10 GW.

THE SYSTEM FOR SPARK CLEANING OF LOW CARBON STEEL

M.V. Zhuravlev, M.S. Slobodyan, B.G. Shubin

Tomsk Polytechnic University, Tomsk, Russia, zhuravlev-misha@mail.ru

The system for spark cleaning of low carbon steel from the oxide film and other contaminants has been investigated. The principle of operation of the unit has been considered. The circuit and block diagrams have been shown. Special attention is paid to the pulse generator, its scheme, current and voltage diagrams have been shown.

THE SYSTEM FOR ATMOSPHERE HF SPACE DISCHARGE

M.V. Zhuravlev, M.S. Slobodyan, B.G. Shubin

Tomsk Polytechnic University, Tomsk, Russia, zhuravlev-misha@mail.ru

The system the formation of self-sustained space discharge for cleaning and disinfection of thin sheets and woven dielectric materials, production of ozone, plasma-chemical reaction and other purposes has been investigated. This device can be used for work with nitrogen, methane, propane and other gases combination.

GUIDING 1-M SCALE DISCHARGE CREATED BY A TESLA GENERATOR TRIGGERED WITH FEMTOSECOND LASER FILAMENT IN AIR

**L. Arantchouk¹, Y. Brelet², A. Houard²,
Y-B André², B. Prade², J. Carbonnel², A. Mysyrowicz²,**

¹*Laboratoire de Physique des Plasmas, Ecole Polytechnique, CNRS, Palaiseau, France, leonid.arantchouk@lpp.polytechnique.fr*

²*Laboratoire d'Optique Appliquée, ENSTA ParisTech, Ecole Polytechnique, CNRS, 91761, Palaiseau, France*

We report experiments on laser guided discharges obtained in air by the high voltage delivered by a compact Tesla coil. The home-made Tesla generator provides bursts of voltage oscillations at 100 kHz with peak amplitude of about 350 kV. The voltage is applied between two spherical electrodes. The discharge is triggered by a laser pulse at 800 nm of 350 mJ energy and 700 fs duration. Before reaching the electrodes, the pulse undergoes filamentation, producing thereby a 2 m long continuous plasma column with a diameter of 5 mm and a nearly constant electron density of $n \sim 10^{16}$ electron/cm³. No electric discharge is produced by the Tesla generator in the absence of the laser when the interelectrode distance is larger than 32 cm because the electric field is less than the critical value for spontaneous breakdown. Guided discharges activated by filament plasma column are obtained up to an interelectrode distance of 150 cm. The triggering of the guided discharge depends sensitively on the laser arrival time with respect to the phase and amplitude of the Tesla voltage cycles. Data on the discharge current, delay between the laser arrival and the initiation of the discharge will be presented. Images of the discharging path guided by the filament will be shown as well.

**LOW JITTER, HIGH CURRENT SPARK GAP OPERATING
WITH AIR AT NORMAL PRESSURE**

**L. Arantchouk¹, A. Houard², Y. Brelet²,
B. Forestier², J. Carbonnel², J. Larour¹, A. Mysyrowicz²**

¹*Laboratoire de Physique des Plasmas, Ecole Polytechnique, CNRS,
Palaiseau, France, leonid.arantchouk@lpp.polytechnique.fr*

²*Laboratoire d'Optique Appliquée, ENSTA ParisTech, Ecole
Polytechnique, CNRS, 91761, Palaiseau, France*

We demonstrate a simple, reliable air spark gap operating at atmospheric pressure and able to switch currents in excess of 10 kA. The spark gap with an interelectrode spacing close to 10 mm is remotely triggered by a femtosecond laser system. This laser delivers pulses at 800 nm of typically 350 fs duration and energy of 200-250 mJ, corresponding to a peak power of about 600 GW. After propagation in air, the weakly converging laser beam undergoes filamentation. This leads to the production of a 1-2 m long continuous plasma column of nearly uniform longitudinal electron density $n \sim 10^{16}$ electron/cm³. The plasma column of diameter ~ 5 mm connects quasi instantaneously two electrodes.

We studied two switch configurations. In first one two cylindrical electrodes of diameter 36 mm pulse charged up to 0.6-1.2 of the self-break voltage (25-30 kV). The triggered laser beam passes through holes 3 and 5 mm diameter. A sub-nanosecond jitter is demonstrated

The second configuration consists of spherical metal electrodes of 10 and 20-mm diameter DC-charged. They are connected to the laser produced plasma channel by grazing contact with vertical electrode shift of 2-3 mm. Jitter of 1-3 ns have been measured here.

COAXIAL PULSED DISCHARGE GUN FOR SYNTHESIZING NANOPARTICLES

**I. V. Beketov, A. V. Bagazeev, A. I. Medvedev, V. V. Ivanov,
A. P. Safronov, O. R. Timoshenkova**

*Institute of Electrophysics UB RAS, 106, Amundsen st., Ekaterinburg,
Russia, 620016, beketov@iep.uran.ru*

Many applications based on small quantities of nanoparticles with a diameter of less than some tens of nanometers such as gas sensors, optoelectronic devices rely on a source delivering a reproducible size and concentration. As well at the present time due to the proliferation of nanotechnologies and their introduction into the industry it is necessary to control the concentration and dispersion of the particles presenting in the atmosphere or released into the atmosphere gases. For this aerosol analyzers which determine particle concentration in the range of 10^6 - 10^9 dm⁻³, an average particle size and a width of the particle size distribution are developed. In this connection there is need for aerosol generators with a given concentration of aerosol consisting of weakaggregated nanoparticles of the required average size and size distribution for the calibration and verification of these analyzers. One of the most promising types of generators suitable for solving this problem is pulsed erosion plasma accelerator (gun). Such the accelerators are used for producing of high-speed plasma flows for surface treatment, plating, producing of powders, etc. In such devices, the particles of the material resulting from erosion of the electrodes are removed from the channel of the accelerator at high speeds. In this case the one hand, a rapid cooling of the particles, which prevents an increase in their size takes place, but on the other - the high speed motion of the particles allows to realize an effective particle separation on fractions of different dispersion. Particle sizes and their concentration in the gas depends on the parameters and conditions of the arc discharge.

A plasma coaxial gun has been made. The power supply to the gun was realized from the current pulse generator with a variable capacitive storage of 0,4-6,4 μF, operating in the microsecond range with the variable period from 3 to 11 μs. Charging voltage of the capacitor bank was varied from 20 to 30 kV, and the frequency from 0.5 to 1 Hz. The length of the accelerating channel was of 100 mm and the inner diameter of 40 mm. Both electrodes of the gun were made of steel. The output of the gun was connected to the of the gas system, consisting of series-connected particle separation and collection devices. In addition, the nanoparticles were trapped on the substrates mount-

ed inside the gas system channel after the large particles separation device. Experiments on producing aerosol were carried out in air at normal pressure. As a result ferric oxide aerosols were obtained at different conditions of the discharge. The produced nanoparticles were analyzed by methods SEM, TEM and their composition by EDX. The resulting aerosols consist of particles belonging to two factions: 3 - 30 nm and 60-200 nm. The analysis results show that the discharge parameters affect the characteristics of the particle size distribution of both fractions. The increase of energy released in the discharge leads to the increase of the width of the distribution. In addition the part of the large particles increases.

The authors acknowledge financial support of RFBR grant 12-08-01155-a.

POTENTIAL APPLICATION OF NANOSECOND PULSED X-RAY IN MEDICINE

**M.A. Buldakov¹, I.A. Klimov¹, O.P. Kutenkov², M.A. Bolshakov²,
N.V. Cherdyntseva¹, V.V. Rostov²**

¹*Tomsk cancer research Institute SB RAMS, Tomsk, Russia,
buldakov@oncology.tomsk.ru*

²*Institute of high-current electronic SB RAS, Tomsk, Russia*

Background. Main radiotherapy problem of cancer treatment is side-effect as a result of high dose of radiation. All of the modern apparatus for cancer therapy are not enough efficient when low-doses applying. It related with the biological sensitivity and reaction of tumor cells on radiation. Biological effects could be increased by using pulse-modulated radiation. It could allowed to significantly decrease radiation dose with saving antitumor efficacy. The source of low-dose repetitively pulsed X-ray radiation was first developed and created at the Institute of high-current electronics (Russia).

Materials and methods. "Sinus-150" as a generator of pulse periodic X-ray was applied. A high-voltage pulse had a half-height duration of 4 ns and amplitude of 260 kV. The calculated photon energy spectrum had a maximum at 90 keV, and most of the quantum flux was the 60-200 keV range. Dose per pulse was 0.3 mR, absorbed dose were 0.18 and 0.65 Gy for 2 experimental groups of animal. Solid-type of Lewis lung carcinoma was prepared by intramuscularly transplanted of 3×10^6 cells into the hind limb of

C57BL/6 female mice. Tumor volumes were measured with calipers and a volume calculated ($L+W+W/2$). The metastases of the lung were counted using a stereoscopic microscope.

Results. Low-dose repetitively pulsed X-ray inhibits growth of Lewis lung carcinoma cells at 54-55%. Effect didn't depend on regime of irradiation (everyday or 4 times per experiment). Same time, index inhibition of metastasis was 60 % in group of everyday irradiation and 43 % in group of 4-times irradiation. Index inhibition metastasis growth was not very high but statistically different compare to control – both experimental group showed 17-19 %. The main difference between the irradiated groups was number of mice without metastasis. In group of 4-times irradiation only 10 % of animal had no metastasis while in group of everyday irradiation half of mice had no metastasis. So, the most effective regime for best antitumor effect is everyday irradiation.

Conclusion. The results is evidence of availability further investigation of repetitively-pulsed low-dose X-ray antitumor effects in case of it's possibility medico-biological application, especially in oncology.

EXPERIMENT STUDY ON HIGH VOLTAGE DISCHARGES AND SOUND CHARACTERISTICS UNDER ATMOSPHERIC CONDITIONS

Chengyan Ren^{1,2}, Jue Wang^{1,2}, Ping Yan^{1,2}, Cheng Zhang^{1,2}, Tao Shao^{1,2}, Jiayu Xu³, Yuanqing Liu³, Huijuan Ran¹, Tao Wang¹, Wenfeng Li¹

¹ *Institute of Electrical Engineering, Chinese Academy of Sciences, Beijing, China*

² *Key Laboratory of Power Electronics and Electric Drive, Chinese Academy of Sciences, Beijing, China;*

³ *China Electric Power Research Institute, Beijing, China
rcy@mail.iee.ac.cn and st@mail.iee.ac.cn*

The transduction mechanism between corona discharge and audible noise was not well resolved, which was closely related with discharge theory. In this paper, the experiment of sing point corona discharge under DC voltage was developed and the sound signal produced by single pulsed discharge was measured. The DC corona discharge characteristics of needle-plane electrodes were studied. The discharge current waveforms and discharge pictures

in different voltages, void spaces, and polarities were obtained. The research results indicate the DC corona discharges were composed of a series of pulsed discharges, the amplitude, pulsed width and repetitive frequency of single pulsed discharge were related with experiment parameters, but had some randomization. Based on the features of single point corona discharges, the pulsed discharge circuit using magnetic compression nanosecond pulse source(30ns/100ns) was set up to simulate different corona discharges. Using capacitor microphone the sound pressure signals produced by single pulsed discharge were measured in anechoic chamber. The correlation features between discharge and sound were preliminarily obtained. The research result provides the foundation to go deep into the audible noise mechanism of transmission lines.

This work was supported by the National Basic Research Program of China (973 Program) (2011CB209402), and National Natural Science Foundation of China (50907069).

DISCHARGE CHARACTERISTIC IN UNIFORM ELECTRIC-FIELD SF₆ GAP UNDER REPETITIVE NANOSECOND PULSES

**Cheng Zhang^{1,3}, Huijuan Ran^{1,2}, Jue Wang^{1,3}, Tao Wang^{1,2},
Tao Shao^{1,3}, Ping Yan^{1,3}**

¹ *Institute of Electrical Engineering, Chinese Academy of Sciences, Beijing, China zhangcheng@mail.iee.ac.cn*

² *Graduate University of Chinese Academy of Sciences, Beijing, China*

³ *Key Laboratory of Power Electronics and Electric Drive, Chinese Academy of Sciences, Beijing, China*

Because of high dielectric strength and some excellent physical and chemical characteristics, sulphur hexafluoride (SF₆) has been widely used as an insulating medium in gas insulated substation (GIS). However, more and more insulation failures caused by very fast transient overvoltage have addressed much attention in order to safe operation of electrical equipments. To a better understanding of discharge progress produced by high voltage pulses with a fast rising time, an experimental study on nanosecond-pulse breakdown in compressed SF₆ with a uniform electric field is presented. A nanosecond pulse generator is used to generate voltage pulses with a pulse rise-

time of 15ns, a full width at half maximum of 30-40ns, and a pulse repetition frequency varying from 1 Hz to 1 kHz. The test electrodes are brass parallel-plane electrodes of 80 mm in diameter. In this research, the parameters affecting breakdown characteristic, such as voltage-current waveforms, repetitive pulse stress time and applied pulse number, are obtained. The dependence of them on the breakdown characteristic is analyzed, especially the variation of the repetitive pulse stress time with applied electric field, pulse repetition frequency, gap distance and gas pressure is discussed.

This work was supported by the National Basic Research Program of China (2011CB209405).

SHOCK WAVES AND BUBBLE EXPANSION IN LOW ENERGY PULSED ELECTRIC DISCHARGE IN WATER

**R.V. Dolinovskaya, Ph.G. Rutberg¹, V.A. Kolikov¹, M.E. Pinchuk^{1,2},
A.G. Leks¹, V.N. Snetov¹, A.Yu. Stogov¹**

Institute for Electrophysics and Electric Power of Russian Academy of Sciences, St.-Petersburg State Polytechnic University, St.-Petersburg, Russia, dolinovskaya@gmail.com

¹*Institute for Electrophysics and Electric Power of Russian Academy of Sciences, St.-Petersburg, Russia*

²*St.-Petersburg State Polytechnic University, St.-Petersburg, Russia*

UV radiation and shock waves play main roles for water disinfection by pulsed electrical discharges among the direct action factors affecting on pathogenic bacteria. The mechanism of bacterial destruction by shock wave is caused by destruction of its membrane due to the pressure drop with amplitude >2 MPa in the shock front. A study of energy transfer mechanisms from discharge channel to shock wave is a promising and under-studied area of researches.

Input energy increasing into discharge channel does not lead to pressure amplitude increase in shock front. From economic and technological points of view it is advantageous to use the lowest power setting.

To study the hydrodynamic structure of shock waves in water discharge system the direct shadow optical diagnostic installation with a time resolution of 5 ns and a spatial resolution of 0.1 mm was designed. Synchronization of

diagnostic system was carried out by original system based on fast optocouplers.

Velocity of bubble growth and shock wave propagation was measured for two power sources: one with voltage 70 kV, pulse duration of 20 μ s and another with a voltage of 50 kV, pulse duration of 10 μ s. Energy in a pulse is about 1 J. Axisymmetric electrodes of tip-tip configuration were varied from 2 to 10 mm.

Velocity of bubble expansion and collapse is about several hundred meters per second at early stage of discharge. Bubble pulsation period is 0.5 - 1 ms. Increasing of energy released in the discharge gap will increase bubble pulsation period.

Pictures of a streamer bush with different structures of the discharge gap breakdown are observed. Analysis of the images showed that two shock waves are formed near the ends of the electrodes and at an early stage expand with the speed of $\sim 2 \times 10^4$ m/s. After about 500 ns in the far Fraunhofer zone both waves merge into one in the form close to spherical, spreading with a rate of $\sim 2 \times 10^3$ m/s.

Numerical simulations of bubble dynamic and shock wave propagation in water under various conditions of energy input were made. Based on the research results some recommendations for adjustment of the system power supply and load parameters were suggested.

DISCHARGE TEA CO₂ LASER WITH SHORT PULSE DURATION

**V. V. Dudarev, I. N. Konovalov, V. F. Losev, Yu. N. Panchenko,
A. V. Pavlinsky, A. V. Puchikin**

*High Current Electronics Institute SB RAS, Tomsk, Russia,
vovadu@gmail.com*

Commercial discharge pulse-repetition rate CO₂ laser developed in HCEI SB RAS is described. It is shown that laser may have different pulse duration by changing the gas mixture composition. The results of experimental investigations of laser radiation parameters for high-quality beams in infrared spectral region are presented. Laser produces the output pulse energy of 0.4 J with pulse duration of 30 ns and it has a total electric efficiency more than 6 %.

Some experiments to determine the optimal gas mixture for short, high-power pulses of electric-discharge CO₂ laser were performed. It is shown that the no helium gas mixture CO₂:N₂:H₂ – 500:50:110 with pressure 0.6 atm is optimal for high-power pulses.

ACTION OF HIGH-ENERGY ELECTRON BEAM ON POLY-CHLORINATED COMPOUNDS ADSORBED ON SURFACES

I.E.Filatov, S.A. Nikiforov, Yu.S. Surkov, V.V. Uvarin

*Institute of Electrophysics, UD of RAS, Amundsen st., 106,
620016, Ekaterinburg, Russia, fil@iep.uran.ru*

High-energy electron beams are used for clearing air from volatile toxic components: SO₂, NO_x and various volatile organic compounds (VOCs). In some cases, the compounds can be adsorbed on surfaces, including surfaces of dust particles. Action of high-energy electron beam on the substances adsorbed on inorganic materials has the specificity and demands separate research.

For modeling such processes we used the substances adsorbed on thin plates for thin layer chromatography (TLC), covered with layers of adsorbents such as: SiO₂, Al₂O₃ and TiO₂. As objects of research have been chosen known ecotoxines as: phelol, polychlorinated phenols, polychlorinated benzenes and polychloro-biphenils. The last were used as isolating oils and there is a problem of recycling their.

For the researches the portable electron accelerator RADAN with the following parameters was used: electron energy - 180 keV, beam current - 400 A, pulse duration - 3 ns, pulse repetition rate - up to 10 Hz. For the analysis of products the method of gas chromatography with mass-selective detector (GC/MS) was used. Preliminary experiments have shown, that phenols and their chloro-derivatives under action of an electron beam in adsorbent layer are exposed to binding in to the structures with the doble amount of carbon atoms. Polychloro-biphenils lose atoms of halogen. Dechlorination is reversible, therefore it is important to select the reagents intercepting chlorine. Search of such reagents is the purpose of the further investigations.

The found regularities allow to carry out analogies between compound radiolysis under action of γ - radiation, photolysis in natural conditions and radiolysis under action of high-energy electron beam with application of the

compact electron accelerator, and also modeling processes of ageing. The received data will be useful to development of new technologies of ecotoxines destruction, also will help to make assumptions about evolution of chlorine-containing ecotoxines on dust in Nature.

SPLITTING OFF CONCRETE LUMPS BY BOREHOLE ELECTROBLAST

**N.A. Ivanov, N.S. Kuznetsova, V.V. Lopatin, A.S. Yudin, V.
Golovanevskiy***

Tomsk polytechnic university, Tomsk, Russia, nikina11@sibmail.com

** Curtin University, Perth, Australia*

The research data of concrete destruction and splitting off to the free surface from borehole electroblast with discharge initiation by the conductor explosion are represented. The wire was situated in different transfer media. The effectiveness of splitting off and destruction was determined depending on different combinations of the tensor media used: gel, water, and polyethylene. The combined use of capillary discharge in the polyethylene and in the gel was shown to lead to the best destruction of the samples. The results of the mathematical modeling and the experimental measurements of voltage and current are represented. The discharge channel resistance and the dynamics of the energy in it in the case of the initiation of the discharge channel by exploding conductor in the water and a polyethylene capillary tube in the water were calculated depending on the diameter of the exploding conductor. The energy release in the first half-period oscillations of the current by ~ 15% was shown to be higher in the capillary discharge channel than in the discharge channel in the water. The critical electric field $E = 2$ kV/cm was determined which yet leads to a breakdown of the metal vapor produced by the explosion of the 0.15-mm diameter conductor in the 0.37-mm diameter capillary. The process of the destruction of rocks and concrete blocks with an electroexplosive polyethylene cartridge and the gel is investigated. It is shown that when the energy stored in the storage capacitance is ~ 30 kJ, the electroblast destruction of the samples up to 100×60×60 cm and the splitting off to the free surface of the 15×15×30-cm pieces take place.

AN EFFECT OF HIGH CURRENT ELECTRON BEAM OF NANOSECOND DURATION ON N-DECANE

Kaikanov M.I., Remnev G.E., Egorov I.S.

National Research Tomsk Polytechnic University, Tomsk, Russia

E-mail: Kaikanov_m@mail.ru

To examine the applicability of pulsed electron accelerators to hydrocarbon processing technology, the effect of the pulse electron beam of nanosecond duration on the n-decane solution is studied. The experiments were performed using the ASTRA-M pulse electron accelerator with the electron kinetic energy of 450 keV, pulse duration of 110 ns and pulse energy of 10 J. The electron beam dose was measured using both the potassium nitrate recommended for measuring the dose of the pulse electron radiation and Fricke solution which was filling into the same type of processing chamber. The average dose rate of electron radiation in the experiments was 2 kGy/s whilst the pulsed dose rate is up to 10^{10} Gy/s. Processing of n-decane solution was carried out in argon/propane-butane mixture filled stainless steel chamber in a stationary mode. The dependence of n-decane conversion rate on the absorbed dose of electron beam radiation at different temperatures was found. The results of gas-liquid chromatography of treated samples are discussed. Treatment temperature was varied from 20 to 200 °C.

PLASMA-CHEMICAL SULPHUR RECOVERY UNDER ACTION OF PULSE ELECTRON BEAM ON SULPHUR HEXAFLUORIDE

G.E. Kholodnaya, R.V. Sazonov, D.V. Ponomarev, G.E. Remnev

Institute of High Technology Physics, Tomsk Polytechnic University, Tomsk, Russian Federation, e-mail: galina_holodnaya@mail.ru

The results of the experimental investigations on sulphur hexafluoride decomposition in the oxygen mixture under the action of a pulse electron beam have been represented. The investigations were performed on the specialized TEA-500 pulse electron accelerator. The parameters of the electron beam are as follows: the electron energy is 450-500 keV, half-amplitude pulse duration is 60 ns, the pulse energy is up to 200 J, the beam diameter is 5 cm. The electron beam was injected to the closed reactor through an anode foil (Al, 140 μm) from the end. The reactor was a stainless steel cylinder with the inner diameter of 20 cm and the volume of 6 l. The impact of the pulse electron beam on sulphur hexafluoride and the mixture of sulphur hexafluoride and oxygen has been studied. We have obtained the data indicating the chemical reaction, whose product is sulphur that X-ray fluorescent analysis confirms.

The study was financed by the Federal Program (State Contract П842).

THE RESPONSES OF MICE LIVER MITOCHONDRIA TO THE REPETITIVE PULSED MICROWAVE AND X-RAY

**I. R. Knyazeva^{1,2}, M. A. Bolshakov^{2,3}, V. V. Ivanov¹, L. P. Zharkova^{2,3},
A. V. Kereya^{2,3}, O. P. Kutenkov², V. V. Rostov²**

¹*Siberian State Medical University, Tomsk, Russia,
e-mail: knyazeva_irekle@mail.ru*

²*Institute of High-Current Electronics, SD RAS, Tomsk, Russia,
e-mail: rostov@lfe.hcei.tsc.ru*

³*Tomsk state university, Tomsk, Russia, e-mail: mbol@ngs.ru*

The importance of the study of biological effects of the microwave and the X-ray radiation with nanosecond pulses is determined by the feature of the influence of this factor. These radiations have a high intensity due to short pulse duration, and accumulated values of the absorbed dose are relatively small. It has been shown that exposure to repetitive pulsed microwaves and X-ray leads to the formation of reactive oxygen species, oxidative modification of biopolymers and changes the permeability of cell membranes. It has been suggested that these changes may be determined by the functioning of mitochondria, which are a source of ROS in the cell and have a strong antioxidant defense system. The purpose of this work was to test this hypothesis. The functional activity of mitochondria and antioxidant enzymes of mitochondria after exposure of the pulsed microwave (4–25 pps pulse repetition rate, 100 - 1520 W/cm² peak power density) and X-ray (8 - 25 pps pulse repetition rate; 0.3–1.8×10⁻⁶ Gy/pulse dose) was investigated. The report will contain the data regarding the effects of repetitive pulsed microwaves and X-ray radiation on the liver mitochondria of mice and will be discussed some mechanisms of effect.

TREATMENT OF INDUSTRIAL AND HOUSEHOLD WASTE WATER WITH THE PULSE ELECTRON ACCELERATOR-BASED SETUP

**D.Yu. Kolokolov¹, I. S. Egorov¹, M.I. Kaikanov¹, L.R. Merinova¹,
G.E. Remnev¹, R.V. Sazonov¹, A.V. Stepanov¹, D.A. Voyno²,
A.S. Maslov², B.A. Siarg²**

¹*NR TPU, IHTP, Tomsk, Russia, e-mal: coastaway@rambler.ru*

²*LLC «Gazprom Transgas Tomsk», Tomsk, Russia*

The results of the operation of the pilot setup on treating the industrial and household waste water have been reported. The given setup is developed on the basis of the “Astra-M” high-current nanosecond pulse-frequency electron accelerator (the electron energy of 475 keV, the ejected beam energy of 10 J, the half-height pulse duration of 75 ns, the repetition rate of 40 pulses/s).

The purpose for the development of the setup is treatment and disinfection of the waste water according to the requirements for Sanitary and epidemiologic rules and regulations (SanPiN) for the treated water dumping to the surface basins of fish household purpose or to the terrain.

The pilot setup comprises the following technological units: an aerator, a coagulator and a mechanical filter, the «Astra – M» pulsed electron accelerator, the «Delta – 123» ion-exchanging module. The aerator is based on the operation of the air-water injector. The mechanical filter is a high-speed pressure filter with the granular loading (quartz sand).

The set-up has two modes of operation: a manual mode and an automatic mode of treatment. The technological process is PC remotely controlled and monitored.

The waste water for testing was brought from the industrial zone Volodino, linear production controls of gas main pipelines (LPCGMP) LLC «Gazprom Transgas Tomsk». The results of the chemical and bacteriological analysis of the untreated waste water revealed the overshoot in chemical and bacteriological indices.

The results of the chemical and bacteriological analyses of the treated waste water with the pilot setup demonstrates a significant decrease in the degree of the bacterial contamination and in the concentration of the chemical substances standardized for the waste water.

**DEVELOPMENT OF PULSED POWER EQUIPMENT FOR
TECHNOLOGICAL APPLICATION IN PRODUCTION OF PURE
QUARTZ**

E. G. Krastelev

Quartz company LLC, Moscow, Russia, ekrastelev@yandex.ru

The paper summarizes results of R&D work intended to development of microsecond and nanosecond pulsed power generators and a related equipment for electro-discharge disintegration of mineral quartz and quartz glass as a basic part for a new technology of pure quartz production. Selective disintegration by electro-discharge fragmentation along material interfaces or grain boundaries is one of the key activities during the last several decades for purification of different minerals. It is well suited for quartz exploration and offers a very efficient method for releasing the quartz crystals. Substantial progress has been made during the last several years in the development and optimization of facilities.

The objective of the work was to design and construct reliable and rather simple for exploration equipment suitable for semi-industrial scale of pure quartz production. Several Marx generators were constructed for the initial fragmentation of rather big pieces (from +60 to -200 mm) of quartz minerals. The main parameters of the Marx generators are the next: voltage amplitude is in a range 160-320 kV, stored energy – from 160 J up to 1 kJ, pulse repetition rate – from 2 up to 10 pps. The installation with Marx generator designed for output voltage of 240 kV and stored energy of 1 kJ is in routine operation. It provides the first step of fragmentation from +100 – -200 mm to – 20 mm with productivity of more than 1t/h at repetition rate of 4 pps and about 700 kg/h at 2 pps. Another Marx generator (240 kV and 250 J) is used for fracturing of minerals from – 60 mm to – 5 mm. Several types of electro-discharge chambers were designed for Marx generators. For purposes of quartz purification the chambers are working with flowing water removing some part of impurities and dust particles.

Installations based on application of nanosecond pulsed power generator were developed for the second step of fragmentation. They are serving for fine grinding and production of high purity quartz materials. The parameters of the nanosecond generator are the next: amplitude of the output voltage – up to 500 kV, duration of a half of period of a discharge current – 70-90 ns, current amplitude – up to 30 kA. The generator consists of a primary low voltage capacitive storage, step-up pulsed transformer, high voltage oil insu-

lated coaxial capacitor and an output gas switch followed by discharge chamber. The design of the generator provides its continuous operation in a pulse-periodical mode with a pulse repetition rate from 10 pps up to 50 pps. Typically it operates at 20 or 30 pps providing throughput up to 180 kg/h of fine grains.

The main parameters of the installations as well as the design features of the generators and discharge chambers will be presented together with the results of measurements of particle size distribution and chemical analysis for several sources of quartz minerals.

LIMITATION OF AVERAGE POWER OF INFRARED LASING IN AR-XE MIXTURE DURING REP-RATED ELECTROIONIZATION PUMPING

D. L. Kuznetsov, Yu. S. Surkov, V. V. Uvarin

*Institute of Electrophysics of the Ural Branch of the Russian Academy of
Sciences, Ekaterinburg, Russia, kdl@iep.uran.ru*

Effective lasing in Ar-Xe mixtures pumped by rep-rated electron beams and discharges is connected with certain difficulties. The experiments showed that limitation of lasing power at wavelength of 1.73 μm during rep-rated pumping is explained by heating of working gas mixture. An installation used in our experiments has allowed us to cool gas mixture during rep-rated pumping and to obtain higher average lasing power. The installation consists of a vacuum diode with a longitudinal explosive emission cathode and gas chamber for a formation of non-self-sustained volume discharge initiated by a nanosecond electron beam. Pulse repetition rate is up to 50 Hz. A gas mixture Ar:Xe = 200:1 at an atmospheric pressure was irradiated. The installation provided cooling of the gas mixture in close cycle by a liquid nitrogen during rep-rated pumping.

In a regime of single pumping pulses the energy of lasing at the wavelength of 1.73 μm was 6 mJ, and the specific energy of lasing – 0.1 J/l per pulse. The efficiency of lasing was ~1%.

Experiments without circulation of gas mixture showed that already with a pulse repetition rate of 1 Hz not an increase, but a sharp decrease in both the energy of separate laser pulse and the average lasing power was ob-

served. A gradual increase in temperature of the gas mixture was observed too.

During experiments with various speeds of the circulation of the gas mixture it was explained that an increase in the speed of the circulation leads to a considerable increase in the values of the average power of laser radiation. Maximum average power of lasing (55 mW) was reached during the pumping with a pulse repetition rate of 10 Hz and with the speed of circulation 1 m/s.

It should be noted that not all advantages of the method proposed by us are realized in this installation. An increase in a speed of circulation of a gas mixture through an irradiated area and cooling system up to 4-5 m/s will allow to obtain almost a linear dependency of an average lasing power on a pulse repetition rate in the range up to 50 Hz. Realization of all advantages of our method will allow to increase values of an average lasing power of a laser on xenon atom pumped by rep-rated electron beam and non-self-sustained discharge significantly.

PULSED ELECTROPHYSICAL METHODS OF TOXIC IMPURITIES CONVERSION IN AIR AND ON THE BORDER OF GAS AND ADSORBENT

D. L. Kuznetsov, I. E. Filatov, Yu. S. Surkov

*Institute of Electrophysics of the Ural Branch of the Russian Academy of Sciences,
Ekaterinburg, Russia, kdl@iep.uran.ru*

Results of experiments on conversion of various toxic impurities in ionized air are presented. Pulsed electron beams of nanosecond and microsecond duration and pulsed discharges were used for the gas ionization. Comparison of special features of removal of toxic impurities in air and on the border of gas and adsorbent is executed.

An influence of sulfur and nitric oxides (SO_2 and NO_x) on the efficiency of its simultaneous removal from air was investigated. It is shown that the removal of a particular oxide species is efficient in the absence of the other oxide. The addition of the other oxide in a small amount resulted in a decrease in the efficiency. Explanation of these results is given.

It was discovered that removal of carbon disulphide CS₂ from air runs more effectively in non-self-sustained discharge initiated by pulsed nanosecond electron beam at electric field strength about 500 V/cm. The result was explained with the use of the model of chain mechanism of CS₂ oxidation in ionized air. However, the wide application of electron beams in real cleaning systems is held in control by some disadvantages. In connection with this larger propagation obtain electric discharge methods, for example using a streamer corona, since similar installations are relatively cheap, reliable, simple in the operation and do not require the creation of the biological protection. Such advantages in the majority of the cases compensate the main disadvantage in the electric discharge systems (somewhat greater specific energy expenditures for conversion in comparison with electron-beam systems). A device for CS₂ removal from air flow by streamer corona is presented. The device will make it possible to overcome the main disadvantages in the electron-beam methods.

The researches of various volatile organic compounds (VOCs) conversion in air flow processed by pulsed electron beam were carried out. It is shown that various types of VOCs have different mechanisms of destruction in the air under the influence of beam electrons and discharge. The main mechanisms are: oxidation, polymerization and decomposition. To increase the efficiency of air purification, the combination of methods can be used, in which the generation of non-thermal plasma combined with adsorption and/or chemical method. Reaction of electron beam interaction carries out with success on the border of phases. For example, polychlorinated phenols are subjected to dechlorination under action of pulsed electron beam at the border section of the gaseous phase with adsorbent.

BLAST-HOLE ELECTRO FRACTURE OF OVERSIZE ROCKS

**N.S. Kuznetsova, V.V. Lopatin, V.V. Burkin,
V.A. Golovanevskiy¹, Yu.P. Stefanov¹**

Institute of High-Technology Physics, National Research Tomsk Polytechnic University, Tomsk, Russian Federation, E-mail: tevn@hvd.tpu.ru

¹ *Western Australian School of Mines, Curtin University, Perth, Australia, E-mail: v.golovanevskiy@curtin.edu.au*

City, Country, e-mail address

² *Institute of Strength Physics and Materials Science, Tomsk, Russian Federation, E-mail: stefanov@ispms.tsc.ru*

The results of electro-discharge fracture of large-size concrete samples with electrical breakdown initiation by the exploding wire are presented. In order to minimize the operating voltage of the pulse generator and to increase the discharge gap and hence the energy absorption by the plasma channel that leads to the fracture build-up, the electro-bursting cartridge (copper wire in polyethylene) was used. With the pulse amplitudes of $\sim (15-20)$ kV and wire length of $\sim (20-60)$ mm, concrete blocks of $700*450*300$ mm size can be fractured. Specific energy deposition of ~ 60 kJ/cm³ leads to the pressure buildup of up to $2.5 \cdot 10^9$ Pa in the discharge plasma channel. Under the action of pressure, the highly conductive plasma channel expands and generates the shock wave, causing the mechanical stress formation in the solid. Elastoplastic deformations and radially propagating cracks are launched into the material and this leads to the sample fracture. The dynamics of the generator energy conversion into the plasma channel and into the wave of mechanical stresses in solid is considered. Electrodischarge fracture can be a cost-effective and practical solution for disintegration of the rock mass by splitting rock fragments off the free rock surface in mining, oil and gas, tunnel construction and similar applications.

NANOSECOND CURRENT GENERATOR BASED ON A SINGLE HCEIcap 80-0.25 CAPACITOR-SWITCH ASSEMBLY**I. V. Lavrinovich, N. V. Zharova, M. G. Bykova***HCEI SB RAS, Tomsk, Russia, lavrivan@mail.ru*

An HCEIcap 80-0.25 capacitor with a 80-kV operating voltage and 250-nF capacitance was developed. The active volume of the pulse capacitor is 3.3 dm³, i.e., at a charge voltage of 80 kV the specific energy output is 240 J/dm³. The capacitor is equipped with a controlled gas-filled switch located in its inside to minimize the total inductance of the assembly and to provide fast energy extraction from the capacitor. The dimensions of the assembly are Ø212 × 250 mm. Tests of the assembly in the short-circuit mode at decreased voltages $U_0 = 22$ kV show that the total inductance of the assembly is 41.5 nH at a current amplitude of 40 kA and rise time of 160 ns. The obtained values suggest that with a charge voltage of 80 kV, the current amplitude in the short-circuit mode can reach 160 kA at the same 160-ns rise time.

**HYBRID FEMTOSECOND LASER SYSTEM ON BASE OF
PHOTOCHEMICALLY
DRIVEN XEF(C-A) AMPLIFIER****V.F. Losev, S.V. Alekseev¹, N.G. Ivanov¹, B.M. Kovalchuk¹, G.A. Mesyats², L.D. Mikheev², Yu.N. Panchenko², and N.A. Ratakhin^{1,3}***Institute of High Current Electronics SB RAS, Tomsk, Russia,
losev@ogl.hcei.tsc.ru*

At present, the development of ultra-high power laser systems with a pulse duration of 10–100 fs is based mainly on near-infrared solid-state titanium-sapphire or parametric amplifiers and amplification of positively chirped pulses, i.e., stretched in time (0.5–1 ns), by linear frequency modulation with their subsequent compression to the initial duration. Stretching of a pulse is required to decrease its power below a threshold at which the beam is self-focused; in solid-state systems, pulses are normally stretched $\sim 10^4$ times.

In recent years, an alternative approach to the design of multi-terawatt and petawatt femtosecond laser systems has been developed at the Institute of High Current Electronics (Tomsk, Russia), Lebedev Physical Institute (Moscow, Russia), and LP3 Laboratory of the Marseille University (Marseille, France). The approach is based on a solid-state femtosecond laser complex (2nd harmonic, 475 nm) and a photochemical XeF(C-A) amplifier with a gaseous active medium. The advantage of this hybrid (solid/gas) design of the high-power femtosecond systems is the admissible stretch factor of femtosecond pulses before their amplification is three orders of magnitude smaller than that for solid-state systems. The nonlinear conversion to the second harmonic to spectrally match the solid-state system with the gaseous active medium and the low gain of the latter give reason to hope for high contrast without resort to any additional optical devices, and this is also a significant advantage this hybrid system. Finally, similar hybrid systems provide an alternative to direct nonlinear conversion of infrared radiation to the second harmonic in solid-state systems in which many problems arise with scaling of output radiation parameters in the visible spectrum to tens and hundreds terawatt.

This paper reports the THL-100 multi-terawatt hybrid laser system with a 25-cm aperture developed at the Institute of High Current Electronics SB RAS and presents results of the first experiments of femtosecond pulse amplification. It was shown that the active medium gain strongly depends on the XeF₂ vapor concentration and distance from the laser cell axis. Maximum 0.004 cm⁻¹ gain of the active medium was measured. In amplification experiments the amplifier input energy was varied from 0.04 to 2 mJ and a negatively chirped to 1 ps pulse was used. In near-saturation conditions of the amplifier (50 mJ/cm²), the output radiation energy increased by a factor of 500 and 1 J maximum energy of the amplified pulse radiation was obtained. At the output energy 0.7 J compression of the amplified pulses in the quartz glass bulk to an initial duration of 50 fs was realized. ASE measurement of XeF(C-A) amplifier in angle of 0.2 mrad gave the power of 1 W. The contrast of output beam was given by seed pulse contrast which is usually ~ 10¹⁰ at least. Thus, a record-breaking peak power of 14 TW in the visible spectrum has been attained.

The work was supported by RFBR (projects No. 10-08-00022, 11-08-98050-r_sibir_a), Federal target program "Scientific and scientific-pedagogical personnel of innovative Russia" (state contract №. 02.740.11.0560), and Grant SB RAS №6.

**RESEARCH OF ATMOSPHERIC PULSED-PERIODICAL
DIFFUSE DISCHARGE****S. P. Maslennikov, E. G. Krastelev, E. Ya. Shcolnikov***National Research Nuclear University "MEPhI", Moscow, Russia,
SPMaslennikov@mephi.ru*

The paper presents the results of an experimental research of atmospheric pulse-periodical diffuse discharge. One of the main directions of the research activity is the analysis of gas discharge ability for industrial applications. Non-thermal gas discharges make it possible to realize a variety of promising plasma techniques for pollution control and biomedical applications, polymer surface treatment etc.

The experimental equipment developed for the experiments includes a high voltage nanosecond power supply system and a gas-discharge chamber with variable electrode system. The main parameters of the pulsed power system are the next: voltage amplitude is variable from 25 to 60 kV, voltage pulse duration (FWHM) – from 50 to 100 ns, the maximal pulse repetition rate equals 1 kHz.

The experiments were performed with electrode systems of two types. The system of the first type has highly non-uniform electric field as a result of application of high voltage electrodes with sharp edges (needle, blade, wire etc.). The second type of the electrode system represents double discharge system, where two kinds of discharges (dielectric-barrier and diffuse) are excited simultaneously. Dielectric-barrier discharge acts as a plasma electrode and as a pre-ionizer of the adjacent gas layer improving spatial uniformity of the diffuse discharge. The inter-electrode gaps for both systems were varied from 0.5 to 3 cm.

The experiments have revealed that the structure and electric parameters of the discharge depend strongly on the configuration of the electrodes and on the operating parameters of the pulsed power supply system. There is a set of conditions for stable burning of the diffuse discharge with preservation of its spatial structure. Overshoot of a certain level of the discharge power results in a spark formation. For explored experimental conditions the power limit of the diffuse discharge is about 0.3 W/cm^3 . Optical emission spectroscopy of the diffuse discharge has shown that its radiation has linear spectrum. The main fraction of radiation is in the ultraviolet part of the spectrum (300-400 nm).

COMPACT DISCHARGE KrF LASER SYSTEM WITH HIGH QUALITY BEAM

**Yu. N. Panchenko, M. V. Andreev, V. V. Dudarev, N. G. Ivanov,
V.F. Losev, A. V. Pavlinsky, A. V. Puchikin**

*High Current Electronics Institute SB RAS, Tomsk, Russia,
ypanchenko@sibmail.com*

Results on the formation of high-quality radiation in a KrF laser system at the edge of the gain and the possibility of using this source in the lidar complex is presented. The laser system consisting of a master oscillator and amplifier, provides the generation of radiation with an energy of 0.3 J and a high quality beam at the edge of the spectral profile of the active medium and is working with a repetition frequency of 100 Hz. Identified the necessary conditions for the interaction of the radiation of the master oscillator and amplifier, allowing to reconstruct the wavelength of the radiation in the spectral range 247,5-249,5 nm, without significant changes in the energy parameters of radiation.

The classic use of a selective resonator in the master oscillator can generate a beam with good quality. However, the presence of a high level of selective and nonselective loss significantly reduces the energy of the output radiation and the spectral tuning range of the lasing line. Designed to be used in the laser generator provided specific power of the pumping 4-4.2 MW/cm³. The research allowed choosing the appropriate configuration of the discharge gap, uniformity and response time of automatic UV preionisation at which a homogeneous volume discharge in the pump pulse 30 ns. The active medium in lasers has good uniformity and high gain of more than 0.08 cm⁻¹.

Using the original optical scheme in the master oscillator with a minimum non-selective losses and increasing it in the active medium of the amplifier under conditions close to saturation, allowed to reach record levels of energy output radiation in the spectral range 247.5-247.8 nm, for this class of lasers. The control system incorporated a laser complex automation of all processes, and implemented automatic stabilization of the given parameters of the radiation. The laser system is adapted to lidar complex, which allows couples to register explosives at a distance of 50 m with a sensitivity of less than 1 ppb.

This work is supported by Russian Foundation for Basic Research (Project No. 11-08-98021-r_Siberia_a) and Grant SB RAS No. 9.

PULSE PLASMA-CHEMICAL SYNTHESIS OF AMORPHOUS PHASE OF NANOSIZE TITANIUM DIOXIDE**D. V. Ponomarev, R. V. Sazonov, G. E. Kholodnaya, G. E. Remnev**

*Institute of High Technology Physics, Tomsk Polytechnic University,
Tomsk, Russian Federation, e-mail:
ponomarev8105@mail.ru*

The paper presents the investigation results of the properties of nanosize titanium dioxide synthesized by the pulse plasma-chemical method. The nanosize oxide was synthesized on the basis of the laboratory facility comprising the TEA-500 pulse electron accelerator and a reaction chamber [1]. The reaction chamber is made of quartz, the diameter is 140 mm and the volume is 6 l. The morphology of the obtained oxide was studied by a JEOL-II-100 transmission electron microscope with the accelerating voltage of 100 kV. The crystal structure of the nanosize powder was determined by using the standard method of X-ray phase analysis. The reaction products were analyzed using a «Shimadzu XRD – 6000/7000» diffractometer.

The investigations have been performed in the symmetrical survey in the angular range 15...60 2θ using 0.02 step size and 1 s exposition in every point. The obtained oxide particles have a round shape; their surface is covered with more round particles. There are also the particles with a cubic facet and a pure surface. The particles of nanosized TiO₂ have an average diameter of 60...110 nm. A specific feature of the obtained oxides is a high content of the amorphous phase (up to 45 %).

The investigation was fulfilled within III *Intercollegiate Competition of TPU Research Projects*, Tomsk, Russia (Project No. 10-03/2012).

PULSE PLASMA-CHEMICAL SYNTHESIS OF NANOSIZED SILICON DIOXIDE FROM METAL-ORGANIC PRECURSOR – TETRAETHOXYSILANE

R.V. Sazonov, D.V. Ponomarev, G.E. Kholodnaya, and G.E. Remnev

*Institute of High Technology Physics, Tomsk Polytechnic University,
Tomsk, Russian Federation, e-mail: sazonr@mail.ru*

The work is devoted to the investigations of the plasma-chemical synthesis of nanosized silicon dioxide from metal-organic precursor (tetraethoxysilane) and to the analysis of the properties of the obtained powder. The synthesis of the nanosized oxide was performed on the basis of the laboratory setup comprising: a TEA-500 pulse electron accelerator and a reaction chamber. The morphology of the obtained oxide has been studied. The chemical and element composition of the solid-phase product of the plasma-chemical synthesis has been determined. The particles of the synthesized nanosized silicon dioxide have a spherical shape, the average size being 40-80 nm. The C – H bond is typical for all synthesized SiO₂ samples.

The investigation was performed within III *Intercollegiate Competition of TPU Research Projects*, Tomsk, Russia (Project No. 10-03/2012).

X-RAYS NANOSECOND BLOOD IRRADIATOR

A.A.Shverikas, M.E.Balezin, S.V.Scherbinin, S.Y.Sokovnin

*Institute of Electrophysics Ural Branch of RAS
106 Amundsen Str., Yekaterinburg, Russia, 620016;mk@iep.uran.ru*

The blood irradiation is used when it is necessary to make the blood transfusion to weakened immunity patients. For this task was created the installation for radiating blood processing RNOK -300 (X-rays nanosecond blood irradiator). The installation was combined rather low X-rays energy, high dose intensively, low price and good maintainability.

Installation contains the nanosecond repetitive electron accelerator, the chamber of irradiation with radiation shield, the detector of pulsed X-rays and control panel.

The big size cathode allows to receive the uniform distribution of x-ray at distance about 5cm that need for homogeneous irradiation a standard blood package (the size nearby 150*150 mm²) in contrast analogues were distance of irradiation were 30-40 cm. It essentially improves the utilization the formed X-rays radiation due to geometry factor, reduces consumed power and irradiation time.

Besides the vacuum diode of RNOK-300 works at low vacuum - not better 10⁻² Pa, has folding execution and can be easily repaired by replacement of the cathode or other element of a design.

ACCELERATOR URT-1M FOR RADIATION TECHNOLOGIES

S.Y.Sokovnin, M.E.Balezin, S.V.Scherbinin

*Institute of Electrophysics Ural Branch of RAS
106 Amundsen Str., Yekaterinburg, Russia, 620016;
sokovnin@iep.uran.ru*

The electron accelerator URT-1M with the accelerating voltage up to 1 MV, the average electron beam power up to 1kW, the pulse width about 100 ns were created to correct drawbacks that were found the URT-1 electron accelerator operation.

New design of the accelerator allows placing the accelerator in placement with the height up to 2.5 m, the Murata capacitors are used in high voltage circuit and the TPI1-10k/75 thyatron with cold cathode was used to switch the energy storage.

The system of the automated monitoring of the accelerator parameters was created to lighten the work of the staff.

For reception the big width electron beam (up to 400 mm) the metal-nanoceramic cathode was created. There were several metal-nanoceramic plates in the cathode to make not more than ~15 % non-uniformity distribution of beam current density on the outlet foil. The accelerator can be used for the radiation technologies in layers by thickness up to 0.3 g/cm².

**RESEARCH OF ULTRA-VIOLET RADIATION THE NANOSECOND
GAS DISCHARGE INFLUENCE ON PATHOGENIC
MICROORGANISMS**

S.Y.Sokovnin, M.E.Balezin, V.V.Lisenkov, A.Bogun

*Institute of Electrophysics Ural Branch of RAS
106 Amundsen Str., Yekaterinburg, Russia, 620016;
sokovnin@iep.uran.ru*

For antiseptic processing the decay tooth cavity after dentist preparation were usually used 2 % of a water chlorhexidine solution or gel on its basis. However chlorhexidine was not active affect to all viruses and dispute.

Besides in case of long using the chlorhexidine solution there was an colouring of tooth enamel and an adjournment of dental stone, infringement of taste and also chemically influences a tooth material and by that changes its adhesive properties that reduces terms of operation of seals or inserts.

Therefore transition from chemical to a physical way of antiseptic processing decay cavities is demanded and now there were active researches in this area. Calculation of output UV radiation from plasma of nanosecond gas discharge has shown an opportunity of such approach.

For creation of UV radiation from plasma the spark gap in air was used, created in edge-edge geometry an (a backlash up to 2 mm). Breakdown was supply by the pulse transformer circuit with output voltage up to 10 kV and pulse width about tens in ns.

Preliminary data show, that the longer tooth cavity was under UV irradiation the remains the survived bacteria less.

CONVERSION OF CH₄-CO₂ MIXTURE UNDER THE INFLUENCE OF NANOSECOND ELECTRON BEAM AND GAS DISCHARGE

V.V. Uvarin, D.L. Kuznetsov, I.E. Filatov

Institute of Electrophysics, Ekaterinburg, Russia, uvv@iep.uran.ru

Plasma-chemical conversion of CH₄-CO₂ mixture promoted by nano-second electron beam and gas discharges was studied.

For gas excitation we used electron beam with electron energy of 200 keV, current pulse amplitude of 200 A and pulse width of 5 ns. As a discharge power source, generator of high-voltage pulses with output voltage of 200 kV, current pulse amplitude of up to 3.5 kA and output pulse length of 15 ns was utilized. Under change of discharge conditions at the device, it was possible to obtain pulsed diffuse or spark discharges.

The performed experiments on the gas-discharge working of the CH₄-CO₂ mixtures of various composition showed that both for e-beam excitation and for the discharge the large quantity of ethane and carbon are produced together with the formation of CO and H₂. The maximum values of conversion (about 80% both for methane and for the carbon dioxide) were obtained with the use of the spark discharge; energy consumption for the conversion of the molecule of methane in this case was about 30 eV per molecule. For the excitation of gas by electron beam and diffuse discharge the conversion values were several times less.

In order to increase the effectiveness of the methane conversion the experiments with the placement of catalysts into the zone of discharge were carried out. Nonmetallic catalysts on the basis of the powders of MgO and CaO were used as the catalysts of the reaction of carbon dioxide conversion. An increase in the degree of the conversion of methane by 28% was obtained with the use of the catalyst on the basis of CaO. The application of the MgO catalyst, on the contrary, reduced the degree of conversion by 65%.

**INSTABILITIES OF HIGH-CURRENT OPEN DISCHARGES
AND THEIR CRITICAL PARAMETERS**

P.A. Bokhan, P.P. Gugin, M. A. Lavrukhin, D. E. Zakrevsky

*A. V. Rzhanov Institute of Semiconductor Physics
Siberian Branch of the RAS, Novosibirsk, Russia, bokhan@isp.nsc.ru*

Open discharge OD (type of discharge that burns in a narrow gap, of width 1 to 10 mm between solid cold cathode and grid anode either in planar or coaxial geometry) is a source of low-energy (up to 100 keV) high-current (up to 30 kA) electron beams EB. Researches of OD in a coaxial and planar geometry revealed the existence of unstable dynamic state of intensive EB which is expressed in high-frequency oscillations of EB current. Development of these oscillations decreases the parameters of EB and restricts probabilities of possible applications, such as for gas lasers pumping.

Unstable dynamic state appears under the $U > U_{cr}$ (4..4.5 kV) and current density $\sim 50 \text{ A/cm}^2$ due to the appearance of uncompensated volume excess of charge which is the consequence of the exponential growth of the current in time and hyperbolic growth of current density in the direction towards the tube axis. An increase in gas pressure and addition of molecular admixtures allow to partly suppress development of oscillations. Transition from coaxial to planar geometry also decreases the possibility of development of instabilities.

**X-RAY EMISSION FROM A NANOSECOND-PULSE DIS-
CHARGE IN AN INHOMOGENEOUS ELECTRIC FIELD AT
ATMOSPHERIC PRESSURE**

**Cheng Zhang¹, Tao Shao¹, Victor F. Tarasenko², Ma Hao¹,
Evgeni Kh. Baksht², Ping Yan¹, Yuliya V. Shutko²**

¹ *Institute of Electrical Engineering, Chinese Academy of Sciences, Bei-
jing, China st@mail.iee.ac.cn*

² *Institute of High Current Electronics, Russian Academy of Sciences,
Tomsk, Russia VFT@loi.hcei.tsc.ru*

In recent years, there is more interest on nanosecond discharge in an inhomogeneous electric field at increased pressure. In the paper, the discharge

is generated in a highly inhomogeneous electric field with a tube-plate gap in air at atmospheric pressure using a solid-state repetitive nanosecond-pulse generator. Output pulse of the generator has a rise time of about 15 ns and a full width at half maximum of 30-40 ns. Electrical characteristics and X-ray emission of nanosecond-pulse discharge in atmospheric air are studied by the measurement of voltage-current waveforms, discharge images, and X-ray emission intensity. The experimental results show that both air gap spacing and anode material affect the characteristic of discharge mode and X-ray intensity of the nanosecond-pulse discharge. It is shown that diffuse discharge with proper air gap generates more strong X-rays than spark and corona discharge with small and large air gaps, and X-rays emission increases with the atomic number of the anode material, which indicates the bremsstrahlung in the region between the dense plasma front and the anode mainly attributes to the X-ray emission in nanosecond-pulse discharge. X-ray emission from discharge was observed for a voltage amplitude of ~12.5 kV in the incident wave.

This work was supported by the National Natural Science Foundation of China under contract 51110161, and the Russian Foundation for Basic Research under contract 12-08-91150-ГФЕН_a.

RUNAWAY ELECTRON BEAM GENERATION IN HELIUM AND AIR AT NANOSECOND DISCHARGE IN NONUNIFORM ELECTRIC FIELD AT FREQUENCY UP TO 1000 HZ

M.V. Erofeev, E.Kh. Baksht, V.F. Tarasenko, Yu.V. Shutko

*Institute of High Current Electronics, Russian Academy of Sciences,
Tomsk, Russia mve@loi.hcei.tsc.ru*

Experiments on runaway electron beam and x-ray generation in helium and air in a pulse-periodic mode of discharge excited in non uniform electric field are presented. Voltage pulses of positive and negative polarity with amplitude in incident wave up to 12.5 kV, with a pulse full width at half maximum (FWHM) about 1 ns and repetition rate up to 1 kHz were applied to point-to-plate gap. Electron beam was registered behind a thin foil in a pressure range from several to tens Torr. X-ray radiation was obtained in a wide range of pressures, as well as at atmospheric pressure of helium and air.

It was shown that at positive polarity of voltage with pulse repetition rate of 1000 and 100 Hz, the best load matching of discharge plasma was realized at helium pressure of 60 and 80 Torr, respectively. Also it was determined that generation of runaway electrons in this mode appeared because of reflected voltage pulses with reverse polarity. These pulses occur due to reflection of main pulse from discharge gap and generator. At negative polarity of voltage pulse with frequency ~ 100 Hz, runaway electron beam registered only during reflected voltage pulses of negative polarity. Increasing of pulse repetition rate up to 1000 Hz leads to appearance of runaway electron beam during the first voltage pulse, as well as during reflected pulses at the discharge gap.

This work was supported by grants RFBR #12-08-91150-ГФЕН_a.

VUV AR2-EXILAMP OF ONE BARRIER DISCHARGE

M.V. Erofeev, D.V. Schitz, V.S. Skakun, V.F. Tarasenko

*Institute of High Current Electronics, Russian Academy of Sciences,
Tomsk, Russia mve@loi.hcei.tsc.ru*

One barrier discharge excilamp operating in argon flow at over atmospheric pressures with flat exit window or in windowless mode are described. Optical characteristics of VUV emission of argon dimers excited by a dielectric barrier discharge in gas flow have been examined. Minimal gas velocity allowed obtain noncontracted discharge with stable power density of radiation due to convectional cooling of discharge gap has been defined. It was shown, that at gas flow velocity of $0.5 \text{ m}^3/\text{h}$ power density of radiation was $0.1 \text{ mW}/\text{cm}^2$ behind a flat LiF window. Further increasing of gas flow velocity allows to obtain power density of radiation up to $10 \text{ mW}/\text{cm}^2$ in the windowless mode. The radiation spectra of the lamp consist of the second continuum of Ar_2 molecule with maximum at 126 nm.

**GENERATION OF FAST ELECTRONS AT ATMOSPHERIC
PRESSURE AIR BREAKDOWN IN GAP WITH COMBINED PLANE-
GRID CATHODE**

**A.V. Kozyrev, E. H. Baksht, I. D. Kostyrya, D. V. Rybka,
and V. F. Tarasenko**

*Institute of High Current Electronics SD RAS, Tomsk, Russia,
kozyrev@to.hcei.tsc.ru*

Breakdown of atmospheric pressure air gaps with combined design of the cathode at the voltage pulse rise rate equal to 10^{14} V/s, including those with picoseconds' temporal resolution, has been studied.

In the space behind the cathode made of thin wires installed in parallel to the thin flat foil a fast electron flow was recorded. The current value recorded behind the cathode of the fast electron beams is essentially influenced by the anode material. At a grid cathode and flat anode, the spectra of runaway electrons generated both in direct (towards the anode) and inverse directions have been reconstructed by the attenuation curves.

Registration of fast electrons behind the cathode foil of the discharge gap containing inside the thin wires under the cathode potential indicates that these fast electrons are generated near the wire surfaces where electric field has its maximum strength. Two processes occurring simultaneously and consistently, and namely: electron acceleration and displacement of the electric field from the cathode space under the wires – allow some part of electrons passing into the “behind-the-cathode”. Dependence of the total number of fast electrons on the anode material indicates that the bremsstrahlung X-radiation is of great importance already at the initial stage of the breakdown development when runaway electrons are formed.

**GENERATION OF INTENSIVE ELECTRON BEAMS IN AN
OPEN DISCHARGE WITH A PLANAR GEOMETRY**

M. A. Lavrukhin, P.A. Bokhan, P.P. Gugin, D. E. Zakrevsky

*A. V. Rzhanov Institute of Semiconductor Physics
Siberian Branch of the RAS, Novosibirsk, Russia, lavrukhin@isp.nsc.ru*

One of the promising application of using runaway keV-energy electrons is pumping of lasers. Such electron energy can be achieved in an open discharge (OD), special kind of glow discharge that burns in a narrow gap, of width 1 to 10 mm depending on the operating voltage, with an extended drift space provided behind the discharge gap. The main feature distinguishing the OD from other types of discharges is its functioning with resonant emission of radiation from working-gas atoms being the main mechanism underlying the emission of electrons from cathode.

For excitation of lasing active media with fast electrons, a coaxial design of the EB source is preferable (previously in such construction 26 kA EB pulses with nanosecond duration were achieved using OD). Nevertheless this construction has some restrictions of its usage due to existence of an unstable dynamic state of EB.

An alternative source of EB is planar construction with two parallel cathode and a grid placed between them. Characteristics of EB generation in such type of construction with cathode area of 100 cm² was examined in this work.

Discharge cell was filled with helium or neon, or in mixtures of the latter gases with hydrogen. Electron beam current duration achieved value less than 1 ns. Current-voltage characteristics and frequency characteristics of EB was examined. To demonstrate promising usage of EB as a laser pumping source generation on self-terminated transition of helium was observed.

NUMERICAL MODELING OF GENERATION OF FAST ELECTRON BEAMS IN SUBNANOSECOND GAS DISCHARGE

V.V. Lisenkov, V.V. Osipov

Institute of Electrophysics UD RAS, Ekaterinburg, Russia

The paper reports about results of numerical modeling of formation of the subnanosecond gas discharge and generation of fast electrons in nitrogen, in air and laser plume.

For calculations we used the one-dimension numerical model consisting of the system of balance equations for slow and fast electrons, ions, and Poisson equation. The kinetic coefficients as function of electric field, including the probability of transition of electrons into escape (or runaway) mode, were received as a result of modeling of electron motion by Monte-Carlo method.

The calculated kinetic constants, electron energy distribution functions probabilities of transition into runaway mode are presented in the paper.

The fast electrons were generated in a laser plume most effectively of all considered examples. In laser plume the high values of E/N (E-electric field strength, N - density of neutral molecules) are realized not by increasing of E, but by reduction of N.

Results of calculations have shown an opportunity of generation of fast beam with a current in a range $\sim 10^2$ - 10^3 A from the laser plume with the length of 5 mm and the area of 0.1 mm².

NARROWBAND RADIATION IN VUV SPECTRAL REGION OF BINARY MIXTURES ARGON (HELIUM) – XENON PUMPED WITH HIGH-VOLTAGE NANOSECOND DISCHARGE

M.I. Lomaev, D.A. Sorokin, V.F. Tarasenko

*Institute of High Current Electronics, Russian Academy of Sciences,
Tomsk, Russia Lomaev@loi.hcei.tsc.ru*

Spectral and time-amplitude characteristics of spontaneous radiation of binary argon (helium) – xenon mixtures pumped with high-voltage nanosecond diffuse discharge are presented. Xenon admixture at a level of 0.005 – 1 % in argon (helium) at pressure of hundreds torr was shown to have a strong

effect on gas discharge plasma radiation spectra near the xenon resonance line ($\lambda = 146,96$ nm XeI, transition $5p^56s(^3P_1) \rightarrow 5p^6(^1S_0)$).

The time behavior and absorption coefficient in xenon of different parts of

argon (helium) – xenon mixtures' spectra are registered. The observed difference both time behavior and absorption coefficient give occasion to suggest that the short – and the long-wave spectral components are radiated with different excited particles or with different transitions of one excited particle.

At xenon content of 0.1 % or less the width of radiation band near the xenon resonance line was shown to decrease up to the width of a monochromator's instrument function and its peak coincides with the peak of the resonance line.

PULSE CORONA AND DIFFUSE DISCHARGES WITH RUNAWAY ELECTRONS IN ATMOSPHERIC PRESSURED AIR

M.I. Lomaev, I.D. Kostyrya, D.V. Rybka, V.F. Tarasenko

*Institute of High Current Electronics, Russian Academy of Sciences,
Tomsk, Russia lomaev@loi.hcei.tsc.ru*

In the atmospheric pressured air generation of runaway electrons during corona and diffuse discharges was investigated. Corona discharge was formed in coaxial lines with inner diameters of 160 and 50 nm, fed by the voltage pulse generators ARINA-2 and RADAN-220, respectively. A runaway electron beam was registered at diffuse discharge both from gas filled diode at the end of the coaxial line and behind the side windows of gas filled coaxial lines.

A runaway electrons current pulse was shown to initiate in a coaxial line as a rule with a negative polarity voltage wave, rejected from the end of the coaxial line before its breakdown.

At corona discharge in a coaxial line the duration of a runaway electrons beam current pulse was confirmed to be about of 100 ps. The relation between amplitudes of runaway electrons beam current pulses generated at diffuse and corona discharges was shown to depend on the interelectrode gap's value in both cases. The delays between current pulses of runaway electrons beams generated in various sections of a coaxial line were measured.

At corona discharge and runaway electrons beam generation was found the cathode's spots on central electrodes of a coaxial line can be absent. The mechanism of a runaway electrons beam generation was analyzed on base of obtained experimental data.

This work was supported by grants RFBR #12-08-00081_a.

**SIMULATION OF THE RUNAWAY ELECTRON BEAM
FORMED IN A DISCHARGE AT ATMOSPHERIC PRESSURE**

E. V. Oreshkin, S. A. Barengolts, S. A. Chaikovsky,* V. I. Oreshkin*

*P. N. Lebedev Physical Institute, Moscow, Russia, E-mail:
oreshkinev@scalpnet.ru*

**Institute of High Current Electronics, Tomsk, Russia*

A numerical model is proposed which allows one to describe the dynamics of the fast electrons injected from the head of an anode-directed streamer. The model is based on solving numerically equations of motion of electrons. In the context of the model, the number of electrons which can be injected from the surface of a streamer is determined by the number of electrons in the Debye layer. Results of numerical calculations show that about 10% of the electrons in the Debye layer are switched to the mode of continuous acceleration.

**PICOSECOND PROCESSES AT THE DELAY STAGE OF
PULSE BREAKDOWN IN OVERVOLTAGE
ATMOSPHERIC GAP**

**A. G. Reutova, S. A. Shunailov, V. G. Shpak, M. I. Yalandin,
G. A. Mesyats¹**

*Institute of Electrophysics UB RAS,
620016, 106 Amundsen Str., Ekaterinburg, Russia, anuta@iep.uran.ru*

*¹Lebedev Physical Institute RAS,
119991, 53 Leninskii Prosp., Moscow, Russia*

Pulse gas breakdown delay (τ) under certain circumstances requires refinements at the overvoltage of ~ 10 . Well known dependences $E/p(p\tau)$ [1] define the delay as a maximum exposure time of electric field (E) before the current appearance in the discharge gap. However, the voltage growth (field) in the gap and the finite time of electron's transfer from the cathode to the anode are not taken into consideration. But, this is a typical pattern for atmospheric discharge centimeter gaps ($p = 760$ Tor), where intense field emission from metal provides multielectron gas ionization near the cathode at the voltages of several hundred kilovolts. And gas photoionization in such gap due to radiation from the cathode plasma has secondary meaning. If the field rise time to the critical value of 500 kV/cm is small, runaway electrons (RE) will be realized. Picosecond runaway electron beam (REB) passes to the anode with the most rapid time and the pulse breakdown delay must exceed this finite flight time. The report gives the corresponding estimations. Experimental data on REB emission start point control are presented at the delay stage of the breakdown. And the effects accompanying the beam passing are demonstrated as well.

The work was supported by the Basic Research Program of the Presidium of RAS "Fundamental problems of pulsed high-current electronics" and RFBR grants 10-08-00081 and 11-08-00145.

GENERATION AND MEASUREMENT OF SUPERSHORT AVALANCHE ELECTRON BEAMS IN ATMOSPHERIC PRESSURE AIR

**D.V. Rybka, V.F. Tarasenko, E.Kh. Baksht, A.G. Burachenko,
I.D. Kostyrya, M.I. Lomaev**

*Institute of High Current Electronics, Russian Academy of Sciences,
Tomsk, Russia RDm@loi.hcei.tsc.ru*

The paper reports on gas diode and cathode designs for producing supershort avalanche electron beams (SAEBs) of highest amplitude in atmospheric pressure air. Procedures for measuring the SAEB amplitude and duration with up to 20-ps time resolution are described. It is shown that the electron beam downstream of small-diameter diaphragms has a complex structure which depends on the interelectrode gap width and cathode design. It is found that the electron beam diameter downstream of the foil anode far exceeds the cathode diameter and corresponds to the foil anode diameter. The number of electrons detected downstream of an Al foil anode of diameter 54 mm and thickness 10 μm is 6.2×10^{10} . It is confirmed that the pulse duration of the total SAEB current from the entire foil anode is much longer than that from small foil areas and depends on the cathode design. With a spherical cathode and collimator of thickness 5 mm and hole diameter 1 mm, the minimum FWHM of the SAEB pulse is ~ 25 ps.

The obtained results allow the following conclusions on the mechanism of SAEB generation in atmospheric pressure air. First, the limitation of the current pulse duration is unrelated to a voltage drop across the gap. Second, at the generation of a runaway electron beam the processes resulted to two peaks SAEB's form can take place. However the maximal amplitudes of a beam current with a one peak SAEB's pulse are registered. Measurements of the beam current downstream of the foil anode of the gas diode with the tubular cathode and small-hole collimator show that the probability of a single-peak SAEB pulse is highest where the interelectrode gap is 12 mm. If the gap is smaller or larger than the optimum gap, a two-peak beam current pulse is most probable.

This work was supported by grants RFBR #12-08-00081_a.

**PULSE CORONA DISCHARGE IN ATMOSPHERIC
PRESSURED AIR**

**D.V. Rybka¹, G.S. Evtushenko², V.Yu. Kozhevnikov¹, I.D. Kostyrya¹,
A.V. Kozyrev¹, V.F. Tarasenko¹, M.V. Trigub²**

¹ *Institute of High Current Electronics, Russian Academy of Sciences,
Tomsk, Russia RDM@loi.hcei.tsc.ru*

² *National Research Tomsk Polytechnic University, Tomsk, Russia*

In the atmospheric pressured air optical and X-radiation of corona discharge is investigated. Spectra of optical radiation in range 200-850 nm are obtained under various parameters of voltage pulse. A fast camera (HiSpec 1, Fastec Imaging Company, USA) was used to capture the discharge images. It was shown that by increasing the voltage pulse, the corona discharge mode changes so that the discharge becomes a source of UV radiation not only 2+ bands of nitrogen, but the bands from cathode matter as well. Also it was shown that formation of diffusive corona discharges in nonuniform electric field under the high pressures is conditioned due to fast electrons and X-rays generation. It is demonstrated that a runaway electron beam in a corona discharge is generated and detected at a distance several times greater than the brightly glowing plasma region of the corona discharge. It was determined that fast electrons from atmospheric discharges generate K radiation quanta with energies of 525 eV. A calculations show that radiation quanta may effectively initiate new electrons near strong field area. Particular process explains forming of diffusive discharge types for positive polarity electrode with small radius of curvature under the atmospheric pressure as well as fast movement cathode streamer.

This work was supported by grants RFBR #12-08-00081_a.

**NUMERICAL MODELING OF RUNAWAY ELECTRON BEAM
FORMATION UNDER DEVELOPMENTAL GROWTH OF
BREAKDOWN OF OVERSTRAINED AIR GAP**

V. A. Shklyaev, S. Ya. Belomyttsev, V. V. Ryzhov

*Institute of High Current Electronics SD RAS, Tomsk, Russia,
shklyae*v@to.hcei.tsc.ru

In the work the results of numerical modeling of developmental growth of breakdown of gas-filled diode with highly inhomogeneous electric field are presented. It is showed that on the initial stage of breakdown developmental growth the runaway electron beam, having the essential effect on the velocity of breakdown developmental growth, is being formed in diode. The energy, gained by electrons of the beam, corresponds with idling tension of the diode, which is higher than tensions of one realizable in the diode at the breakdown. The character of emissive surface of the cathode defines the moment of formation of the beam on the leading edge voltage pulse and, consequently, beam current and energy spectrum of runaway electrons.

**NUMERICAL SIMULATION OF FAST ELECTRONS
GENERATION IN ATMOSPHERIC PRESSURE
INHOMOGENEOUS GAS MEDIA**

V. A. Shklyaev, V. V. Lisenkov¹, V. V. Ryzhov

*Institute of High Current Electronics SD RAS, Tomsk, Russia,
shklyae*v@to.hcei.tsc.ru

¹ *Institute of Electrophysics UD RAS, Ekaterinburg, Russia*

The paper presents the results of our theoretical investigations of the fast electron beam formation in high-temperature gas of the laser plume and further acceleration of electrons in atmosphere. The discharge formation in this inhomogeneous media was also investigated.

It's well known, that the basic problem of fast electron generation is the requirement of high E/N (E - electric field strength, N – number density of gas molecules) applying for transition of noticeable part of electrons into continuous acceleration (runaway or escape) mode. The required high values

of E/N ($\sim 10^5$ - 10^6 V/ (cm atm) or 10^3 - 10^4 Td) could be implemented only in areas of electric field amplification, for example, in front of the spark channel, near the cathode of special shape, etc., at mean electric fields $<10^3$ Td. Taking into account, that the part of escaping electrons is the function of E/N , we suggest to increase this parameter not by increasing E , but with a help of decreasing N , by making high-temperature area near the cathode.

Such area can be, for example, the laser plume or the spark channel, that finished their thermal expansion.

For numerical simulation of this problem we used modified open-source PIC/MC code *xoopic*, which was elaborated for solutions of vacuum electronics and gas discharge problems.

We received the space and energy distribution of fast electrons, the dynamic of fast electron and discharge currents, the dynamic of voltage on the gap and other characteristics of the discharge.

DIFFUSE DISCHARGE PRODUCED BY REPETITIVE NANO-SECOND PULSES IN OPEN AIR

Tao Shao¹, Cheng Zhang¹, Ping Yan¹

¹ *Institute of Electrical Engineering, Chinese Academy of Sciences, Beijing, China* st@mail.iee.ac.cn

Atmospheric-pressure gas discharge excited by high voltage pulses with fast rise-time and short duration has attracted significant attention for various applications. In this paper, discharges were generated in a highly non-uniform electric field by point-plane gaps in open air by different repetitive nanosecond-pulse generator. One generator produced voltage pulses with a rise time of 25 ns and a full width at half maximum (FWHM) 40 ns across a high-resistance load. The other generator produced high voltage pulses with a rise time of 15 ns and a FWHM of 30-40 ns. The experimental results show that there were typical discharge fashions, i.e. corona, diffuse, filamentary modes. The variables affecting the discharge characteristic, including the gap spacing, pulse repetition frequency, applied pulse parameters, were investigated. Especially, the diffuse discharge was investigated and discussed. Especially, X-rays from the discharge were detected by a PMT and a multi-channel analyzer located 10 cm below the air gap. Characteristic of measured X-rays on the discharge modes were studied, and it indicates that a diffuse

discharge is ignited due to preionization of the gap by runaway electrons and x-rays.

This work was supported by the National Natural Science Foundation of China under contract 51110161, and opening project of State Key Laboratory of Electrical Insulation and Power Equipment in Xi'an Jiaotong University under Grant EIPE12204.

NANOSECOND CORONA DISCHARGE IN ATMOSPHERIC PRESSURE AIR: RUNAWAY ELECTRONS AND X-RAYS

Tao Shao², D.V. Rybka¹, V.F. Tarasenko¹, Cheng Zhang², A.V. Kozyrev¹, I.D. Kostyrya¹, Ping Yan², V.Yu. Kozhevnikov¹

¹ *Institute of High Current Electronics, Russian Academy of Sciences, Tomsk, Russia RDM@loi.hcei.tsc.ru*

² *Institute of Electrical Engineering, Chinese Academy of Sciences, Beijing, China st@mail.iee.ac.cn*

The characteristics of a corona discharge in atmospheric pressure air were studied using pulse generators that produce voltage pulses of different durations, polarities, and shapes. The characteristics were measured in the single pulse mode, batch mode, and repetitive pulsed mode. It is shown that with a rise rate of the voltage ($dU/dt \sim 10^{15}$ V/s) across an electrode of small curvature radius, a corona discharge starts developing as a conical diffuse discharge near the electrode tip, no matter what the voltage pulse polarity. With lower rise rates of the voltage ($dU/dt \sim 10^{13}$ V/s and less), one or several diffuse jets stream from this electrode. The diameter of the jets at their front is less than 1 mm and depends on many factors (voltage pulse amplitude and rise time, interelectrode gap width, pulse repetition frequency, etc.). It is found that at long voltage pulse durations, the radiation spectrum of the corona discharge changes, and the bands and lines of the material of electrode appear in the UV region at 200–300 nm. It is demonstrated that in a corona discharge a runaway electron beam is generated and detected at a distance several-fold larger than the brightly glowing plasma region of the corona discharge. It is shown that X-rays are generated from a corona discharge at high pulse repetition frequencies up to 1 kHz.

This work was supported by grants RFBR #12-08-00081_a and #12-08-91150-ГФЕН_a, and NSFC contract 51110161.

**GENERATION OF RUNAWAY ELECTRONS AND X-RAYS
IN DIFFUSE DISCHARGES IN AN INHOMOGENEOUS
ELECTRIC FIELD**

V. F. Tarasenko

*Institute of High Current Electronics, Russian Academy of Sciences,
Tomsk, Russia VFT@loi.hcei.tsc.ru*

The paper reports the properties of supershort avalanche electron beam (SAEB) and x-ray formed in different gases at pressures from 1 torr up to 15 atm. An electron beam was obtained behind foil at the pressure of sulfur hexafluoride and xenon in a gas diode up to 2 atm, at the pressure of nitrogen up to 5 atm and at the pressure of helium up to 15 atm. It is shown that at a nanosecond discharge in the atmospheric pressure air and SAEB current recording through a small area of the foil the pulse duration behind the foil can be about 25 ps, but from all surface of foil is about 100 ps. It is shown that the highest amplitudes of SAEB with pulse duration about 100 ps are attained in helium, hydrogen, and nitrogen at a pressure of about 60, 30, and 10 torr, respectively. Using the extracted data, estimates show that with the pulser SLEP used, optimization of all parameters of the gas diode makes possible a SAEB current amplitude of about 500 A at a helium pressure of 60 torr. As the mode of the beam generation is changed due to the decrease in pressure from the above values, one can gradually control the FWHM of the beam current pulse between 100 and 500 ps in all gases studied. It is demonstrated that SAEB is generated into an angle exceeding 2π sr in the air at the pressure of 1 atm. The work was supported by grant RFBR #12-08-00105-a.

**SPARK DISCHARGE FORMATION IN AN INHOMOGENEOUS
ELECTRIC FIELD**

**V.F. Tarasenko, E.Kh. Baksht, M.V. Erofeev, M.I. Lomaev,
D.A. Sorokin, Yu.V. Shutko**

*Institute of High Current Electronics, Russian Academy of Sciences,
Tomsk, Russia VFT@loi.hcei.tsc.ru*

We present data that were obtained on the diffuse-to-spark discharge transition. It is shown that with high electric field strengths, point-to-plane gap, and cathode spots, a spark leader can propagate from the planar anode to the cathode of small curvature radius. We believe that the high velocity of cathode leaders and streamers can be explained by the generation of runaway electrons in the region of electric field amplification at the front of the anode streamer. As the leader moves to the anode, the runaway electrons preionize the region upstream of the leader and decrease the potential gradient. Hence, the electric field strength ahead of the front of the anode leader decreases and its velocity decreases as well. In the repetitively pulsed mode, successive breakdowns and sparking are affected by local heating of the electrodes in electrode spots, and this accelerates the formation of spark channels with increasing the PRF and decreasing inter-electrode gap spacing. It is shown that with high rates of rise of the voltage across the gap, cathode spots are formed in a corona discharge in a time ~ 200 ps. Anode spots are formed once the dense plasma bridges the gap or where the dense plasma approaches the anode for a short voltage pulse rise time. The emission spectra of the spark diffuse and corona discharges in the electrode region and in the gap are much different. In the REP diffuse discharge and corona discharge in nitrogen and air, the nitrogen second positive system is most intense, and this suggests that the plasmas from these discharges are in a nonequilibrium state. The spark discharge in the gap is characterized by a broadband continuum in the visible and near-UV regions with narrow bands and lines of the gas atoms and ions. In the near-electrode regions, in addition to the broadband continuum, intense radiation of vapors of the electrode materials is observed. In the repetitively pulsed mode, the radiation of the electrode materials is observed, not only from the near-electrode regions, but from the middle of the gap, as well.

The work was supported by grant RFBR #12-08-00105-a.

**SPECTRUM OF RUNAWAY ELECTRONS IN ATMOSPHERIC
PRESSURE AIR DURING SUBNANOSECOND BREAKDOWN**

**V.F. Tarasenko, E.Kh. Baksht, A.G. Burachenko, V.Yu. Kozhevnikov,
A.V. Kozyrev, I.D. Kostyrya**

*Institute of High Current Electronics, Russian Academy of Sciences,
Tomsk, Russia VFT@loi.hcei.tsc.ru*

In this work, the spectra of electron beams produced in air-filled diodes at atmospheric pressure were studied for different cathode designs. The feasibility of correct reconstruction of the electron beam spectrum from an experimental dependence of its attenuation factor in foils of different thickness was demonstrated. The electron energy distributions were calculated on minimum a priori assumptions by regularization of an ill-posed problem – a Fredholm integral equation. It can be stated that the reconstruction of the spectrum of a short electron beam from its attenuation in foils of different thickness through solving an ill-posed problem by the Tikhonov regularization method provides physically based and unambiguous results. The spectra of a subnanosecond electron beam generated in the gas gap during the voltage pulse rise time were reconstructed and analyzed. All electrons can be divided into two-three groups. The distribution of the main group of electrons has the maximum corresponding to 60–70 % of the electron energy for which the voltage amplitude across the gap is eU_m . The energy of electrons of the low-energy group is <70 keV. For the diode with the spherical cathode, a group of electrons (about ≤ 10 % of the total number of fast electrons) with an anomalous energy formally greater than the maximum voltage drop across the diode eU_m is revealed; however under these conditions, there is a high instability of the delay time between the beginning of the voltage pulse and the onset of the beam current. With the sharp-edged cathodes (in the form of a thin foil tube), the beam current amplitude and the electron energy distribution display stable pulse-to-pulse reproducibility. A time-of-flight spectrom-

ter study and reconstruction of the spectrum from the data on beam attenuation confirmed the fact that groups of electrons with two-three characteristic energies can be generated in gas-filled diodes. In experiments, electrons of energy greater than that corresponding to the nominal voltage amplitude across the gap were detected. The work was supported by grant RFBR #12-08-00105-a.

**11th International
Conference on Modification
of Materials with Particle
Beams and Plasma Flows**

**ADVANCED SOURCES FOR PLASMA AND ION-BEAM
SURFACE MODIFICATION TECHNOLOGIES****A.F. Alexandrov, E.A.Kralkina, V.B.Pavlov, A.K.Petrov, K.V.Vavilin***Physical faculty of MSU, Russia, ekralkina@mail.ru*

The paper represents the results of the authors many year work in the field of ion&plasma sources development as well as their utilization in surface modification technologies.

The main physical principle of the developed DC gridded ion sources (30, 50 and 100mm in diameter) is the utilization of the glow discharge for generation of electrons in the cooled hollow cathode of the ion source. This gives the opportunity to use chemically reactive gases as working gases of the ion source contrary to filament and “hot-hollow cathode” ion sources that are very sensitive to the presence of oxygen, moisture and other contaminants. The ion beam energy can be varied within 300-1500eV, while the ion current density can be changed in the range 0.5 – 5mA/cm². The gridless modification of the DC ion source was used in surface modification technology as a source providing plasma flow enriched by the presence of molecules dissociation products.

The main physical principle of the developed RF ion sources (50, 100 and mm in diameter in case of cylindrical sources and 150x200mm in case of linear ion source) and plasma reactor (460cm in diameter) is the utilization of the external magnetic field which value corresponds to the resonant conditions of helicons and Trievpiece-Gold waves excitation. This gives the opportunity to achieve high efficiency of RF power input to plasma both in cases of reactive and inert gases usage. In case of gridded RF ion source the ion beam energy can be varied within 300-1500eV. The gridless (50mm in diameter) model gives the opportunity to obtain ion beam with the energy about 50eV.

The above mentioned sources can be used in surface modification technologies only in high vacuum conditions. In parallel to devices working under vacuum conditions the prolonged source working at atmospheric pressure was developed.

The surface modification of PTFE, PI carried out using original ion beam, low and atmospheric pressure plasma technologies showed that ion beam and low pressure plasma technologies provide approximately similar increase of adhesion of polymers. The atmospheric pressure technology pro-

vides worth result. In case of metals cleaning the atmospheric technology showed high prospectivity.

GENERATION OF ARK PLASMA FOR MATERIAL PROCESSING

**A. S. Anshakov^{1,2}, E.K. Urbakh¹, O.G. Volokitin³,
A.E. Urbakh¹, and V.S. Cherednichenko²**

¹*Kutateladze Institute of Thermophysics SB RAS, Novosibirsk, Russia,
anshakov@itp.nsc.ru*

²*Novosibirsk State Technical University, Novosibirsk, Russia,
alif@ngs.ru*

³*Tomsk State University of Architecture and Building,
Tomsk, Russia, volokitin_oleg@mail.ru*

The electric-arc generators of thermal plasma (plasmatrons) are applied for high-temperature treatment of article surfaces, powder materials, ore concentrates and other engineering processes. The choice of plasma generator construction is determined by technology demands.

Investigation results on jet and melting plasmatrons are presented in this report; radiant fluxes from the arc column in the plasmatron with a sectioned interelectrode insertion are determined for the media of nitrogen, air and helium. Examples of application of integral arc radiation in melting furnaces and for the processes of surface treatment of materials are presented.

Efficiency of air heating with high energy and source indexes is shown at the example of the two-chamber plasmatron with the stepped electrode. The long service life of the copper tubular electrode is achieved due to the construction of melting plasmatron. At arc discharge currents of 650–700 A in nitrogen working medium the service life of electrode is 500 h and more.

**MULTI-TURN TIME-OF-FLIGHT MASS SPECTROMETERS
ON THE BASIS OF THE CYLINDRICAL ELECTRIC SECTORS**

**O.A. Baisanov, I.F.Spivak-Lavrov¹, A.Zh. Imangazina¹,
G.A. Doskeev¹**

Air Forces Defense Institute named after T.Ya. Begeldinov, Aktobe, Kazakhstan, baisanov@mail.ru

¹*Aktobe's State Zhubanov University named after K.Zhubanov, Aktobe, Kazakhstan, spivakif@rambler.ru*

Recently research connected with the creation of multi-cascade time-of-flight mass- spectrometers, see, for instance, [1], has been developing rapidly. If the time-of-flight mass - spectrometer contains N identical time-of-flight cascades with T₀ time of flight of one cascade, the mass resolution of mass- spectrometer is determined by the formula [1]:

$$R_m = \frac{NT_0}{2(\Delta t_i + N\Delta t_0)} = \frac{T_0}{2\left(\frac{\Delta t_i}{N} + \Delta t_0\right)}, \quad (1)$$

where Δt_i is an initial width of ionic pulse, Δt_0 is the time-of-flight aberrations of one cascade. Thus, the resolution of the time-of-flight mass spectrometer can be increased at the expense of the increase of the number of cascades N and reduction of aberrations of the cascade Δt_0 .

In the cylindrical condenser spatial and time-of-flight focusing of paraxial beams to a circular axial trajectory in sector $\pi/\sqrt{2}$ takes place.

Some circuits of multi-cascade time-of-flight mass analyzers on the basis of a cylindrical sector and planar electrostatic mirrors are offered. One of the circuits is connected with the use of two identical cylindrical sectors, each of which turns the beam through 180°. The ionic beam enters condensers at a little angle and goes along a spiral trajectory. On the lowermost coil of the spiral the beam turns round to the opposite direction with the help two planar netless mirrors.

Another multi cascade circuit is based on the use of one cylindrical sector, to which the flat electrodes, cut along the forming cylinders adjoin from the butt end. Here it is also possible to apply the mirror system reflecting an inclined beam in the opposite direction.

To ensure the repeated passage of a beam in the cylindrical condenser, it is possible to use also the system of mirrors ensuring spatial and temporary focusing of the beam. As such mirrors, for instance, two-dimensional mirrors

can be used. Each pair of mirrors turns the beam through 180° and displaces it vertically. The resolution can be improved by means of the increase of the number of cascades.

References

1. Yavor M., Verentchikov A., Hasin J., Kozlov B., Gavrik M., Trufanov A. Planar multi-reflection time-of-flight mass analyzer with ajig-saw ion path // Physics Procedia. Proceedings of the Seventh International conference charged Particle Optics (CPO-7). – Vol. 1, Iss. 1, 2008. – P. 391-400.

ADVANCED ICP PLASMA SOURCE FOR HIGH DENSITY PLASMA GENERATION

Berlin E.V., Grigoriev V.U., Shchelkanov I.A.

*“Laboratory of Vacuum Technologies”, Zelenograd, Russia,
berlin.lab@mail.ru*

Inductively coupled plasma (ICP) sources are intensively developed and investigated all over the world. “Laboratory of vacuum technologies, Itd” has recently developed a new type of radio-frequency plasma generator (RFPG). This RFPG has a flat inductor coil. Inductor’s diameter is 125 mm, operating frequency is 13.56 MHz, and RF power can be varied between 200 W and 1500 W.

Influence of an external magnetic field on ICP discharge parameters and its stability is investigated to increase efficiency of the device. External magnetic field is generated by Helmholtz coils, which are set coaxially around inductor. Plasma parameters, discharge stability, and matching efficiency greatly depend on the magnetic field lines profile and magnetic flux density.

Optimal parameters of magnetic field provide a stable ICP discharge with the following parameters: RF power 1000 W, argon gas pressure 75 mPa, substrate diameter 100 mm, distance between inductor and substrate 200 mm, plasma ion density no less than $2.5 \cdot 10^{12} \text{ cm}^{-3}$, the substrate ion saturation current is 32 mA/cm². Also a stable discharge obtained in various gases and their mixtures in a broad range of pressures for 10 mPa to 1 Pa, gases are: argon, nitrogen, oxygen, air, carbon dioxide, methane, sulfur hexafluoride.

Investigation of some of possible implementations of the RFPG in various technological applications was carried out.

First, a nitriding of stainless steel (SST 316L) samples was carried out. Samples were shaped as a small cylinder with the height about 7 mm, and diameter 15 mm. During the process they were placed on the grounded substrate, 200 mm away from RF-inductor. The RF power was 1000 W, gas Argon/Hydrogen=1/1, pressure 400 mPa, sample temperature about 450 °C. As the result the average microhardness of the sample surface increased up to 5 times.

Second, a deposition of a nonconductive hard coatings from methane gas was carried out. Samples were made from stainless steel and placed onto a water cooled substrate. RF power was 1000 W, methane pressure 100 mPa. Obtained coating had a relatively good adhesion, and breakdown voltage more than 100 V.

Third, a triode electrode system was used to deposit aluminium and aluminium nitride films. During the deposition an aluminium target was placed in ICP discharge plasma and biased up to -200 V. Stainless steel and glass samples were placed in front of aluminium target 100 mm away from it. Deposition of alumina was carried out in argon gas, aluminium nitride in the mixture of nitrogen and argon gases. In each process deposited coatings were dense and homogeneous.

The radio-frequency plasma generator (RFPG-128) is an advanced device which allows to generate high density plasma in a relatively large volume with any operational gas or gas mixtures. It does not require any specific measures to be kept operational. Its body is made from aluminium alloy, and designed to be installed as a conventional flange with the diameter 128 mm. A specific design of its body and inner elements provide a stable geometry of induction coil which leads to a repeatability of operational regimes during all life time of the device.

EFFECTIVE VOLUMINOUS PLASMA ARC SOURCES IN TECHNOLOGICAL VACUUM-PLASMA SETUPS

**D.P. Borisov, N.N. Koval^{1,2}, A.D. Korotaev¹, V.M. Kuznetsov¹,
V.Ya. Romanov¹, P.A. Terekhov¹, and E.V. Chulkov¹**

Tomsk State University, Tomsk, Russia, borengin@mail.ru

¹ *Tomsk State University, Tomsk, Russia, dean@phys.tsu.ru*

² *Institute of High Current Electronics SB RAS, Tomsk, Russia,
koval@opee.hcei.tsc.ru*

In this paper characteristics and parameters of plasma arc generation in large vacuum volumes of technological setups are presented. This paper also describes a lot of a new models of vacuum-plasma sources for effective vacuum-plasma-arc techniques of surface modification of articles.

AUTOMATED SETUP OF HF MAGNETRON DEPOSITION OF BIOCOMPATIBLE COATINGS

**V.V. Denisov, V.V. Shugurov, A.A. Kalushevich, R.A. Surmenev¹,
M.A. Surmeneva¹, A.A. Ivanova¹, I. Yu. Grubova¹, V.F. Pichugin¹**

*Institute of High Current Electronics SB RAS, Tomsk, Russia,
volodyadenisov@yandex.ru*

¹ *National Research Tomsk Polytechnic University, Tomsk, Russia*

To correct defects in bone basis or replacement of damaged sections of tissue implants, which in the process of functional use will inevitably corrode and destroy are used in modern implantology.

Therefore, using of medical devices often do not develop the required interaction of artificial surfaces with bone tissue, there is a risk of complications.

A combination of "implant + biocompatible coating" allows to combine high mechanical properties of the base material and biological quality of the coating, which gives the surface properties of the implant as close to the properties of bone tissue, which improves the ability of implant to integrate with the body.

The method of RF magnetron sputtering allows creating nanostructure thin films with specified properties. The aim of this work was to create an automated setup of RF magnetron deposition of biocompatible coatings.

The setup is fully automated for high repeatability of complex technological processes. The operating program has planning sheet which contains a few hundred steps in common technological process. There is the opportunity to operate by the inleakage of 3 different gases in necessary proportions with automatic stabilization of pressure.

The research was supported by the TomskPolytechnicUniversity (Grant № № 11-03/2012), as well as the grant of the President of the Russian Federation for young Russian scientists - candidates of sciences (MK-1149.2012.8)

SCALING OF DLC CHEMICAL VAPOR DEPOSITION METHOD WITH THE USE OF PLASMA CATHODE

**D. R. Emlin, S. A. Plotnikov¹, N. V. Gavrilov, I. S. Trachtenberg¹,
I. G. Khatmullin**

IEP UB RAS, Ekaterinburg, Russia, erd@iep.uran.ru

¹ *IPM UB RAS, Ekaterinburg, Russia, sp55555@mail.ru*

Parameters of plasma generated in a large volume (0.34 m³) chamber by means of pulse (50 kHz, 10 ms) injection of electrons at energy 50-400 eV emitted from self-maintained DC glow discharge plasma generated in electrode system of plasma cathode with grid stabilization (GPC) were investigated. Two GPC were used in the work, with summarized emission current 6 A.

The peak currents of pulse non-self-sustained discharge were adjusted at 15 A level, and ion current density in experiments did not exceed 1 mA/cm². Such conditions provide a high rate of deposition of diamond-like coatings (DLC) at low temperatures excluding their overheating and graphitization. The nonuniformity of argon plasma did not exceed 20 % in the area of ~ 400x400 mm² size.

Test results of industrial-scale vacuum coater UVNIPA 1-002 completed by two GPC and intended for DLC-deposition are given. Voltage-current characteristics of the discharge in Ar+C₂H₂ gas mixture were obtained, and the dynamics of gas conditions in the processing chamber at deposition of coatings by means of gaseous-phase method were investigated.

The obtained DLC at optimal deposition rate $\sim 1\mu\text{m/h}$ possess microhardness $\sim 17\text{-}30\text{ GPa}$. Up to 10 at.% Ar and O are contained in DLC.

**ELECTRON BEAM FACILITY FOR IMPROVMENT OF
CORROSION RESISTANCE OF FUEL ELEMENT CLADDINGS**

**V. I. Engelko, V. G. Kovalev, K. I. Tkachenko, E. P. Pavlov,
A. A. Petukhov, N. P. Shchegolikhin**

*Efremov Institute of Electrophysical Apparatus, St.Petersburg, Russia,
pavlov@mit.niefa.spb.su*

Improvement of corrosion resistance and operational properties of fuel element claddings is possible by of modification of the classing surface with the help of pulsed intense electron beam (PIEB). Thermophysical calculations and experiments show that the necessary electron beam parameters are the following: kinetic energy of electrons – 120 keV; pulse duration $\sim 40\text{ us}$; PIEB energy density on a target - in the range from 25 to 45 J/cm². To realize these parameters the electron accelerator forming radial converging electron beam was designed and manufactured. The design of an electron source is based on multi-point cathode with controlling discharge. Experiments showed that PIEB pulse duration (and consequently energy density) is restricted mainly by two factors: gas and plasma flow from the target and oscillation of electrons in the space between the cathode and target. The influence of the target processes on the source operation can be essentially diminished with the help of preliminary heating the target by current pulse with the amplitude of 400 A and pulse length of 40 s. The oscillation of electrons was suppressed with the help of intercepting electrodes.

Preheating the target and intercepting oscillating electrons allowed to generate the PIEB with required parameters.

**GASEOUS PHOSPHOROUS SOURCE FOR GENERATION
OF MOLECULAR PHOSPHOROUS ION BEAMS
FOR ION IMPLANTATION**

**V. I. Gushenets, A. S. Bugaev, E. M. Oks, A. Hershcovitch¹,
and T. V. Kulevoy².**

*Institute of High Current Electronics SB RAS, Tomsk 634055, Russia,
gvi@opee.hcei.tsc.ru*

¹*Brookhaven National Laboratory, Upton, New York 11973, USA,
hershcovitch@bnl.gov*

²*Institute for Theoretical and Experimental Physics, Moscow 117218,
Russia, kulevoy@itep.ru*

Clusters and molecular ions are promising in terms of their use in the semiconductor industry for high-dose low-energy ion implantation. The report presents the results of experiments carried out to produce molecular beams of phosphorus ions (P_2 and P_4) in a modified hot-cathode Penning-type ion source. In order to reduce the operating temperature of the discharge chamber below 800°C and to prevent thus noticeable dissociation of phosphorus vapor P_4 , the discharge chamber of the ion source was equipped with a cooling system. As a source of phosphorus vapor, phosphine was used, which in its normal conditions is gaseous compound of phosphorus and hydrogen (PH_3). Phosphine is fed to the special designed cracker, which had a active zone temperature close to 700°C, and next phosphine dissociation products H_2 and P_4 piped into the discharge chamber. During the experiments, we obtained an ion beam with a fraction of the ions tetraphosphorus reaching 30% and complete absence of phosphorus compounds with hydrogen such as PH_3 and PH .

The work was supported in part by RFBR research program (RFBR grant 12-08-00183-a)

AUTOMATIC VACUUM ION-PLASMA SETUP

**A.A. Kalushevich, V.V. Shugurov, N.N. Koval, V.V. Denisov,
V.V. Yakovlev**

*Institute of high current electronics SB RAS, Tomsk, Russia,
kalashman@sibmail.com*

Principle of operation, construction and main parameters of new vacuum ion-plasma setup for arc nitriding and plasma-assisted deposition of nanostructure coatings are considered. The new setup is assigned for scientific researches with multicomponent composite cathode for generation of strain-hardening and protective coatings on tools.

The setup is fully automated for high repeatability of complex technological processes. The operating program has planning sheet which contains a few hundred steps in common technological process.

The extended plasma source with heated cathode (PINK) and switch-mode power supply for high-voltage bias on substrate give the opportunity to carry out ion cleaning, etching and activation of substrate surface, arc nitriding of tools. The extended plasma cathode with heated cathode provides high uniformity treatment of large size details.

Two types of arc evaporators - extended and cylindrical types are used. Extended arc evaporator allows deposit uniform coating on the large extent details and reduces the number of microdroplets in the coating. Cylindrical evaporators are used for the deposition of composite coatings. Combining the two types of arc evaporators allows vary widely parameters of the coatings and opens a wide field for research.

There is the opportunity to operate by the inleakage of 2 different gases in necessary proportions with automatic stabilization of pressure. Switch-mode power supplies provides stable values of composite cathode currents and automatic discharge initiation in case of arc starvation. The setup main parameters, technical characteristics and supposed application fields are presented.

FEATURES OF THE FUNCTIONING PLASMA ELECTRON SOURCE BASED ON DISCHARGE WITH HOLLOW CATHODE AT HIGH PRESSURES

A. S. Klimov, A.A. Zenin, A.V. Kazakov, V.A. Burdovitsin, E.M. Oks

Tomsk State University of Control System and Radioelectronics, Tomsk, Russia, klimov@main.tusur.ru

The results of investigation of the possibilities of increasing the working pressure limit for plasma electron source based on a hollow-cathode discharge are presented. It was established experimentally that at pressures over 20 Pa the current of high-voltage glow discharge significantly increases. This fact limits the ability to independently control the value of the emission current and accelerating voltage of electron source. It is shown that optimization the geometry of the accelerating gap can increase the electric strength of accelerating gap and reduce the current of high-voltage glow discharge. In this case the working pressure limit is 50 Pa for air at the maximum beam current 60 mA and accelerating voltage 10 kV in DC regime.

MODEL OF THE ELECTRIC DISCHARGE IN THE CROSSED ELECTRIC AND MAGNETIC FIELDS

D.V. Korzhenko, V. P. Krivobokov, S. N. Yanin

Tomsk polytechnic university, Tomsk, Russia, dman@tpu.ru

Computer model based on the methods of molecular dynamics and Monte-Carlo was developed. This model considers electrons' motion in the magnetic field along target's surface and electrons' drift towards the anode and ionization process of the operating gas. Also the model traces motion of secondary, tertiary etc electrons. Input parameters for the model are initial electric-field strength, magnetic induction, pressure of the operating gas in the vacuum chamber. Base for the modeling is solution of the classical motion equations of the electron in the crossed electric and magnetic fields.

The average force method based on the expansion of the sought function neighboring in a Taylor series neighboring the coordinate of the moving particle was used for numerical solution of the equations set. Ionization's proba-

bility of the argon atoms was counted after each iteration of the calculation of the electron's motion as a ratio of the traveled path to the mean free path of the electron.

The concept of the model is in the next. Electron gains energy during its motion in the crossed electric and magnetic fields. When gained energy becomes enough for the collision ionization of the argon atom (electron's energy becomes bigger than ionization potential of the operating gas atom) then with calculated probability electron may ionize the atom of argon. Then electron's energy decreases by the value of the ionization potential and electron continues its motion in the initial direction.

Size of the dark cathode space was determined from these calculations. Electron accelerates in this space and gains most of its energy which is required for the collision ionization of the argon atoms. Dark cathode space is 0.5 mm for typical for the magnetron discharge values of the electric field strength and magnetic induction.

Model considers motion of the secondary, tertiary etc electrons, which were born during the motion of the primary electron. Calculations show that area of the intensive ionization stretches for 5 mm from the target towards the anode. Obtained results agree well with known experimental data.

Further development of the model will be directed to the research of the spatial distribution of the redundant charge and energetic ion distribution depending on the applied voltage and magnetic field configuration. Such model will make it possible to optimize magnetic system for the maximum sputtering ratio.

THE INFLUENCE OF ANTENNA SYSTEM CONFIGURATION ON THE DISCHARGE PARAMETERS OF THE INDUCTIVELY- COUPLED PLASMA SOURCE

D. Kotov, A. Yasunas

Izovac Ltd., Minsk, Republic of Belarus, kotov@izovac.com

The technology of plasma etching and plasma enhanced chemical vapor deposition of high-density plasma with inductively coupled discharge are making increasingly heavy demands on the uniformity of distribution of concentration and energy of plasma particles generated by inductively-coupled discharge source. Therefore, the dependency definitions and understanding of

the regularities of the discharge formation and distribution of plasma parameters in the area of technological processing is necessary for the design of new high-density plasma sources.

The paper presents the results of probe measurement of the inductively-coupled discharge plasma parameters. Depending on the geometry of the antenna system configuration of a cylindrical inductively-coupled discharge source on the plasma density and electron temperature, were obtained. The method of probe measurements of plasma parameters of RF discharge by a single cylindrical probe was described.

INVESTIGATION OF THE INFLUENCE OF GUIDING MAGNETIC FIELD AND MAGNETIC FIELD OF THE BUS-BARS ON LOW-ENERGY ELECTRON BEAM DENSITY DISTRIBUTION

Le Huy Dung, T.V. Koval

Tomsk Polytechnic University, Sovetskaya Str. 84, 634034, Tomsk, Russia

At the moment low-energy (10-30 keV) high-current (up to 20 kA) electron beams are very important and widely used in practice, such as for surface treatment of materials. Typically, the pulse duration of such beams are a few microseconds, the energy density of the beams is sufficient (up to 20J/cm²) for the pulsed surface melting of any materials, including refractory metals.

Today in many scientific investigations, development and support for low-energy high-current electron beams are necessary and irreplaceable condition. And there is a big task: “how to control it?”

In this paper we investigate “the influence of guiding magnetic field and magnetic field of the bus-bars on low-energy electron beam density distribution”

We will consider the following points:

The influence of an external magnetic field and magnetic field of the bus-bars on current-passage and cross-section transformation of the beam is considered.

The influence of ferromagnetic inserts on the autograph and density distribution of a high-current beam on the collector is investigated.

Numerical simulation is carried out in MATLAB environment with the method of large particles.

The results of theoretical investigations are compared with experiments.

**INVESTIGATION OF INFLUENCE OF THE PLASMA CHANNEL
INHOMOGENEITY ON CURRENT- PASSAGE OF THE LOW-
ENERGY HIGH-CURRENT ELECTRON BEAM**

Le Huy Dung, T.V. Koval

Tomsk Polytechnic University, Sovetskaya Str. 84, 634034, Tomsk, Russia

In normal conditions (in air or in a vacuum), the beam current is limited in the order of tens of amperes. But for many modern scientific experiments, need a high-current (20 kA) electron beam. Such a beam can be carried out only in the plasma channel. Thus, necessary to take into account the influence of the plasma channels inhomogeneity on current- passage of the low-energy high-current electron beam.

First of all, we need to take mathematical modeling of transport of low-energy high-current electron beam in plasma channel. It is shown that the plasma channel inhomogeneity affects the energy losses in the current-passage and the distribution density of the electron beam on the target.

Numerical investigation is conducted with the use of packages MATLAB, COMSOL and PIC-code. Results of the study are compared with experiments.

**STUDY OF PLASMA PARAMETERS OF NON-SELF SUSTAINED
ARC DISCHARGE OF "PINK" PLAZMOGENERATOR****I.V. Lopatin, N.N.Koval, S.S.Kovalsky, P.M.Schanin***Institute of High Current Electronics, Tomsk, Russia,
lopatin@opee.hcei.tsc.ru*

The paper analyzes the changes in the average values of the discharge current and discharge burning voltage depending on the discharge current (CVC), the pressure in the chamber and the external magnetic field induced by the magnetic coil. These dependences with the instantaneous values of the plasma parameters in the center of the chamber, measured at the maximum discharge current where compared.

Plasma parameters measurements by the probe method was carried out. A single cylindrical probe mounted in the center of the vacuum chamber was used. The probe potential supplying and the probe current-voltage characteristics (CVC) measuring using an automated system of the probe characteristics measuring which was specially designed and created were performed. There are 4000 measuring shot at multiple probe potential changing from - 90 V to 90 V for each experimental condition were fixed. The obtained values of probe potential and its current were averaged and smoothed.

In the analysis of the probe current-voltage characteristics that in the studied plasma is two electron velocity groups is present was taken into account. So the probe current-voltage characteristic analysis method allowing to evaluate the temperature and concentration of electrons in the two electron velocity groups separately was used.

The concentration of nitrogen plasma in the center of the chamber reaching $n \approx 1.2 \times 10^{17} \text{ m}^{-3}$, and the temperature of fast velocity group electron reaching $T_{ef} \approx 6 \text{ eV}$ was found.

**DISTRIBUTIONS OF ELECTRIC POTENTIAL AND PLASMA
CONCENTRATION IN THE ANODE REGION OF A LOW
PRESSURE GAS DISCHARGE.**

V. Ya. Martens, S. V. Moiseev

*North Caucasus Federal University, Stavropol, Russia,
vmartens@yandex.ru*

This report describes the processes in the anode region of low pressure gas discharge in long discharge tubes in view of the directed motion of electrons and ions, which is caused by the carrier concentration gradient and the electric field. The paper contains calculations of axial distributions of electric potential and plasma concentration in the anode region. The principle of forming of negative and positive anode potential drop was explained by diffusion and drift manners of movement of electrons and ions. The explanation to appearance of the maximum in the distribution of plasma density near the anode given that anode potential drop is negative is presented.

**BEAM-ASSISTED DEPOSITION USING A SOURCE
OF METAL VAPOR MIXED WITH FAST GAS MOLECULES**

Yu. A. Melnik, V. P. Bolbukov, S. N. Grigoriev, A. S. Metel

*Moscow State University of Technology "Stankin", Russia,
ametel@stankin.ru*

A source of metal atom flow, which coincides in time and space with a flow of fast gas molecules, was developed and used for beam-assisted deposition of various functional thin films. The fast particles are produced at argon and/or nitrogen pressure 0.2–1 Pa as a result of charge-exchange collisions of ions accelerated by potential difference between the plasma emitter of the source and the secondary plasma inside the processing vacuum chamber. As an ion emitter is used plasma of glow discharge with electron confinement in an electrostatic trap formed by a 260-mm-diameter, 100-mm-deep cold hollow cathode and a 200-mm-diameter emissive grid the latter being negative both to the cathode and the chamber. Metal atoms are produced as a result of

a 160-mm-diameter target sputtering, the target being placed at the bottom of the hollow cathode. The ions are accelerated from the plasma emitter by variable up to 3 kV negative bias voltage of the target. Sputtered metal atoms pass through the plasma emitter and together with accelerated gas ions enter the chamber through the emissive grid with 80% transparency. Due to collisions with gas molecules inside the chamber accelerated ions turn into fast gas molecules with variable from tens of electronvolts to several kiloelectronvolts energy. Slow ions are produced as a result of charge exchange collisions and neutralization of their space charge by secondary electrons from the chamber walls results in production of secondary plasma. Current of slow ions in the chamber circuit through a feedback resistor between the chamber and the emissive grid induces a negative potential of the grid, and the source characteristics depend on its resistance.

At high resistance $R = 5\text{--}500\text{ k}\Omega$ the grid totally cuts the electron current from the chamber to the source, accelerating the ions voltage of several hundred volts between the plasma emitter and the secondary plasma is a little less than the cathode fall of the discharge and depends on the gas pressure and the equivalent current of fast molecules. Using an additional DC power supply, connected to the feedback resistor, it is possible to increase the potential drop between the chamber and the grid and thus regulate energy of fast molecules assisting film deposition from zero to several hundreds of electronvolts. At low resistance $R = 20\text{--}200\ \Omega$ electrons entering the source play a leading role in the emitter production.

PULSED ELECTRON GUNS ON THE BASE OF GLOW DISCHARGE WITH ELECTROSTATIC ELECTRON CONFINEMENT

A. S. Metel, Yu. A. Melnik

*Moscow State University of Technology "Stankin", Russia,
ametel@stankin.ru*

Two types of pulsed electron guns with plasma emitters have been studied the emitters being produced by glow discharge with electrostatic confinement of electrons. In the gun of the first type a cold 180-mm-diameter and 600-mm-long hollow cathode is used as an electrostatic trap for electrons, escaping from the cathode through a 60-mm-diameter orifice into a hollow an-

ode. Through holes of the anode grid electrons are extracted from the discharge plasma filling the anode and accelerated by high voltage pulse. Using a 160-mm-diameter spherical gridare formed converging beams withneutralizedspace charge. At argon pressure 0.02 – 0.05 Pa and distance 600 mm from the grid centerthe beam diameter diminishes to an equilibrium value of 10 mm. At accelerating voltage amplitude 250 kV and the pulse width 250 μ s the beam current amplitude reaches 250 A. Energy capacity of the beamis limited by ~ 15 kJ due to transitions of theglow discharge to arc resulting in breakdowns of the accelerating gap.

Electrostatic trapof the other gunincludes a hexagonal prism composed of 204 spaced by 1.5 mm 5-mm-diameter and 200-mm-longcathoderods, as well as 780cathoderodsimmersed in the plasma filling the prism anddistanced from each other at 10 mm. The trap center is free of the rods and filled with plasma emitter between the discharge anode with emissive grid and the trap bottom covered by 23-mm-diameter cathode discs. All the cathode rods and discs are isolated from each other and connected to the discharge power supply through TVO-2 resistors with 430- Ω resistance. At the gas pressure ~ 0.01 Pa this gun produces pulsed 170-mm-diameter beams with current up to 700A of electrons with 300-keV energy at the pulse width 200 μ s. Current limitation in the circuit of each cathode element by 2 A makes it possible at the pulse width $\tau \sim 5$ ms of glow discharge current up to 1 kA to exclude transitions to arc and to produce an uninterrupted pulse of electron beam with a quite uniform distribution of the current density all over its cross-section area of ~ 0.025 m². In this casethe beam energy capacity up to 40 kJ is mainly limited byfixed width of the high-voltage pulses.

PLASMA IMMERSION BROAD BEAM SOURCES OF FAST ATOMS AND MOLECULES

A. S. Metel

*Moscow State University of Technology “Stankin”, Russia,
ametel@stankin.ru*

Broad beams of fast atoms and molecules are produced in plasma filling a vacuum chamber at nitrogen, argon or helium pressure 0.1–10 Pa. Fast particles appear due to charge exchange collisions of ions accelerated in the sheath surrounding a negative grid immersed in the plasma. The plasma is produced by glow discharge with electrostatic confinement of electrons the chamber itself being used as a trap for them. At argon pressure $p < 0.1$ Pa from a flat grid are propagating in opposite directions two broad beams of electrons their energy amounting to $e\varphi$, where φ is potential difference between the plasma and the grid. When p rises from 0.1 to 1 Pa, in the beams appear fast neutral particles with continuous distribution of their energy from zero to $e\varphi$. Those particles progressively substitute for electrons and power, which they transport to the chamber walls, grows with pressure up to $\sim \eta\varphi I$, where η is geometrical transparency of the grid and I is the current in its circuit.

When p further rises from 1 to 10 Pa, the total power of neutral particles does not change, but their mean energy ε reduces from $\varepsilon \sim e\varphi/2$ down to $e\varphi\lambda_c/d$, where λ_c is the charge exchange length of ions, d is the sheath width, and the equivalent current of the fast neutral particle beams grows up to $\sim \eta Id/\lambda_c$. Decrease of ε down to ~ 100 eV leads to reduction in the content of electrons in the beams by an order of magnitude.

The beam propagating from concave surface of a 0.2-m-diameter grid is focused within a 10-mm-diameter circle and the power density on the target surface exceeds 10^7 W/m².

When in the plasma is immersed a hollow cylinder with two end grids or covered by end disks cylindrical grid, then accelerated ions pass through the grid holes, turn inside the closed space into fast atoms or molecules and escape from it through the opposite grid holes. Doppler shift of spectral lines allows of measuring the fast particle energy, which corresponds to potential difference between the plasma inside the chamber and the plasma produced as a result of charge exchange collisions inside the closed space. It allows of producing beams of homoenergetic neutrals their energy ranging from a hundred up to tens of thousands eV and to use the beams for etching any materials, including dielectrics, or implantation.

**INDUSTRIAL ELECTRON BEAM FACILITY FOR MODIFICATION
OF GAS TURBINE ENGINE BLADES**

**V.I. Engelko¹, V A. Shulov², A S. Novikov³, KI. Tkachenko¹,
E P. Pavlov¹, N P. Shchegolikhin¹, V G. Kovalev¹, A A. Petukhov¹,
N G. Beruchev¹, A.V. Pavlenko¹, V A. Chumichev¹, V M. Baev¹,
A N. Daniltsev¹, V L. Demidov¹, M A. Latmanizova¹,
Yu G. Cherepanov¹, T N. Makarova¹**

¹*Efremov Institute of Electrophysical Apparatus, St.Petersburg, Russia,
pavlov@mit.niiefa.spb.su*

²*Moscow Aviation Institute, Moscow, Russia, shulovva@mail.ru*

³*Central Institute of Aviation Motors, Moscow, Russia,
Alexandr.Novikov.49@mail.ru*

The GESA-MMP facility is intended for modification of gas turbine engine blades surface by pulsed intense electron beams (PIEB) having the following parameters:

- kinetic energy of electrons - 100 ~ 125 keV;
- pulse durations - 10 ~ 45 us;
- repetition frequency - ≤ 0.033 Hz;
- PIEB energy density on the target - 15 ~ 50 J/cm²;
- PIEB diameter the target - 70 - 100 mm depending on degree of the beam compression.

As a source of electrons the multi-point cathode with controlling discharge (CCD) is used. Accelerating structure was optimized to provide stable and reproducible operation of the facility.

High voltage pulse is formed by Marx generator consisting of 4 stages. Each stage represents an inhomogeneous pulse forming line. Gas filled three electrode spark-gaps are used as switches. Additional circuits are used to ensure necessary rise-time of the voltage and potentials on the accelerating structure elements.

PIEB is transported to the target by applied magnetic field with the maximum value near the target around 0.2 T.

The PIEB pulse duration is controlled by a cutting off spark-gap.

Operation of the facility is organized by a system of automatic control, providing algorithm of blades treatment, including the PIEB energy density on the target, blade position under the beam, number of pulses in every position, the values of angle of the blade rotation, data conservation and treatment, etc.

**INSTALLATION FOR MAGNETRON SPUTTERING OF
MULTILAYER LOW-EMISSION COATINGS ON A POLYMER
ROLL FILM**

S.V. Rabotkin, N.S. Sochugov, N.F. Kovsharov, M.M. Pugovkin

*Institute of High Current Electronics SB RAS, 2/3, Akademichesky ave.,
Tomsk, 634055, Russia, rabotkin@yandex.ru*

A computer-controlled installation for magnetron sputtering of multi-layer low-emission coatings on polymer roll films was made. The acceptable roll width was up to 1,2 m and the film length not less than 40 m. The installation allows depositing of durable heat-saving coatings with insulator-metal-insulator structure on a polymer film. The film thickness was in the range of 50-200 μm . The transparency of the coatings in the visible spectrum was of 85-87% and its reflection in infrared spectral range was not less than 91%.

**BEHAVIOR OF MACROPARTICLES NEAR AND ON A SUB-
STRATE IMMERSSED IN A VACUUM ARC PLASMA AT NEGATIVE
HIGH-FREQUENCY SHORT-PULSED BIASING.**

A. I. Ryabchikov, D. O. Sivin, A. I. Bumagina

*National research Tomsk polytechnic university,
634050, Tomsk, Lenin Ave. 2a, e-mail: ralex@tpu.ru*

It was found that the negative repetitive pulsed biasing of a substrate with respect to the adjacent plasma significantly reduce the MPs content on surface. The decrease of MPs on the negative potential substrate surface is caused by several different physical mechanisms. Up to 10% of macroparticles (MPs) can be repulsed from the plasma-substrate voltage drop after being negatively charged in plasma. The MPs surface density on substrate can be significantly reduced after MPs interaction with negatively biased metal surface. This physical mechanism of negatively charged MPs electrostatic repulsion disappears when tungsten grid is used to create a sheath near the substrate surface. Reduction of MPs surface density almost by half takes a place due to ion sputtering. The decrease of MPs surface density by factor of 12 was achieved after the treatment of substrate for 2 min.

**INVESTIGATION OF BEHAVIOUR OF THE VACUUM ARC
MICRODROPLETS NEAR AND ON THE SURFACE OF THE
POTENTIAL ELECTRODE DURING SHORT-PULSED HIGH-
FREQUENCY PLASMA-IMMERSION ION IMPLANTATION**

A.I. Ryabchikov, D.O. Sivin, A.I. Bumagina

*National research Tomsk Polytechnic University, 634050, Lenina 2,
bdg. 4, Tomsk, Russia*

Phone (3822) 41-68-59, E-mail: ralex@tpu.ru

The experimental results of investigation of the vacuum-arc macroparticles (MPs) density decreasing on the sample surface due to their reflection from the bias electric field and transformation of sizes, shape of microdroplets, evaporation of them and reflection from the substrate surface at a repetitively-pulsed negative bias potential are presented. It was established that the MPs density on the substrate surface is determined by the amplitude and duration of the negative bias pulse and processing time. It was shown that the density of MPs of the size less than 1.5 μm decreases by 1500 fold at the pulse repetition rate 10^5 Hz, bias potential amplitude 2 kV, pulse duration 8 μs and processing time 9-18 min. The total MPs density in these conditions decreases by 67 times.

**MULTIFUNCTIONAL PLASMA SOURCE WITH HIGH LIFE-
TIME TWO-LAYER ELECTRON EMITTER.**

**M.V. Shandrikov¹, A.V. Tyunkov², A. V. Vizir¹, G. Yu. Yushkov¹
and E. M. Oks^{1,2}**

¹*Institute of High Current Electronics, Tomsk, Russia,
shandrikov@opee.hcei.tsc.ru*

²*Tomsk State University of Control System and Radioelectronics,
Tomsk, Russia*

The plasma source on the basis of DC high-current bulk gaseous discharge with electron injection, sectioned sputtering electrodes and high lifetime two-layer electron emitter was designed. As an electron emitter the plasma of constricted arc discharge was used. However, the typical arc

discharge with hollow cathode is characterized by a relatively high cathode erosion rate, leading to low cathode lifetime and contamination of gaseous plasma by the erosion products. These problems were solved in our present design by using a two-layer inner surface of the cathode cavity of electron emitter. The body of the cathode was made of metal having a high current threshold for cathode spot formation. The cathode cavity was covered with a metal film with a low arc current threshold. In the current range between these thresholds, the body is not subjected to cathode spot erosion and the inner metal migrates inside the cavity with multiple sequential deposition on its inner surface. Thus the lifetime of the cathode body is not limited. As an emitter body metal, Cu, Mo, and Ta were used. Mg and Bi were used as inner, working metals, in all combinations.

Due to the presence of electron injection and the special design of the arc emitter, the plasma source has a very high maintenance period. The total time of the source operation in oxygen plasma atmosphere was more than 500 hours. The developed plasma source has been successfully used both for bulk plasma generation of different gases (argon, nitrogen, oxygen, acetylene) and for the composite metal and oxide films coatings.

INVESTIGATION OF NON STEADY STATE LOW-CURRENT DISCHARGES FOR DIELECTRIC ADHESION INCREASING

**I. A. Shemyakin, Yu. D. Korolev, O. B. Frants, N. V. Landl,
V. S. Kasyanov, A. V. Bolotov and V. G. Geiman**

*Institute of High Current Electronics, Tomsk, Academichesky Ave, 2/3,
Russian Federation, shemyakin@lnp.hcei.tsc.ru*

It is known that one of the key ways to improve the adhesion of polymers based on surface modification under the influence of non-equilibrium plasma of gas discharges. Various forms of stationary and quasi-stationary discharges are widely used to obtain the plasma, such as glow discharge, RF, microwave, and a surface barrier discharge etc. This paper is devoted to the studying of non steady state low-current discharges, which are able to deliver the plasma flows to the surfaces of small size, having a complex shape.

Pulsed discharge burning in a flow of air at atmospheric pressure in the low-current plasma torch electrodes is considered. The initial voltage applied

to the gap amounts is less or equal to 5 kV with an average current of about 0.1 A and a frequency of 1 kHz.

Scheme of power supply for the discharge gap is presented. Results of a study of the emission spectrum of gas discharge plasma are presented and preliminary analysis of the reactions and processes occurring in the gas is made. Set of experimental data on the dependence of discharge regimes vs the geometry of the plasma torch nozzle is obtained. Conditions to significantly improve the adhesion of the surface of polystyrene liner for holder of needle in medical syringe are selected.

PLASMA GENERATION COMPLEX FOR EXTENDED DETAILS TREATMENT

V.V. Shugurov, A.A. Kalushevich, V.V. Denisov, V.V. Yakovlev

*Institute of High Current Electronics SB RAS, Tomsk, Russia,
shugurov@inbox.ru*

The ionic-plasma surfacing of details and mechanisms allows to improve their operating characteristics considerably. So, for example, the deposition of a wearproof coating on shovels of steam turbines allows to prolong term of their service to five times. The ionic-plasma nitriding allows to increase service life of shafts and the sprockets especially working in the conditions of the high transferred moments in three-five times. At conducting of ionic-plasma machining of extended details by means of traditional generators of the plasma which majority is represented by axial-symmetric designs, there are problems of uniformity of treatment. For the solution of these problems by collective of authors has been developed plasma generation complex for machining of extended products. plasma generation complex consists of the extended plasma source with heated cathode (PINK-P), the extended arc evaporator with scanning of a cathode spot and the automated power supplies of plasmagenerators.

In the given work the design, a principle of work of plasmagenerators and power supplies are presented. Acquisition possibility extended энерго-комплексом ionic-plasma installations of type NNV and VU-2 is shown. Work parameters of plasma generation complex and characteristics of the inoculated layers of details and products are resulted.

**MECHANISMS AND REGULARITIES OF THE VACUUM ARC
MACROPARTICLES BEHAVIOR NEAR AND ON A SUBSTRATE,
IMMERSED IN PLASMA**

A. I. Ryabchikov, D. O. Sivin, A. I. Bumagina, V. K. Struts

*National research Tomsk polytechnic university,
634050, Tomsk, Lenin Ave. 2a, e-mail: ralex@tpu.ru*

It was found that the negative repetitive pulsed biasing of a substrate with respect to the adjacent plasma significantly reduce the MPs content on surface. The decrease of MPs on the negative potential substrate surface is caused by several different physical mechanisms. Up to 10% of macroparticles (MPs) can be repulsed from the plasma-substrate voltage drop after being negatively charged in plasma. The MPs surface density on substrate can be significantly reduced after MPs interaction with negatively biased metal surface. This physical mechanism of negatively charged MPs electrostatic repulsion disappears when tungsten grid is used to create a sheath near the substrate surface. Reduction of MPs surface density almost by half takes a place due to ion sputtering. The decrease of MPs surface density by factor of 12 was achieved after the treatment of substrate for 2 min.

SIMULATION OF THE MAGNETIC TRAP BASED ON MAGNETIC FIELDS WITH AXIS OF SYMMETRY

I.F. Spivak-Lavrov, O.A. Baisanov¹

*Aktobe's State Zhubanov University named after K.Zhubanov, Aktobe,
Kazakhsta, spivakif@rambler.ru*

¹ *Air Forces Defense Institute named after T.Ya. Begeldinov, Aktobe,
Kazakhstan, baisanov@mail.ru*

Usually magnetic traps are created by means of non-homogeneous fields (“the principle of magnetic stopper”). At that the charged particles are reflected from areas with a strong magnetic field. However, other configurations of magnetic fields allowing to keep the charged particles in a limited area are possible.

We considered the movement of the charged particles with an e charge and m mass in a homogeneous magnetic field with B_0 induction and I field of an infinite direct current parallel to a homogeneous magnetic field. The induction of a magnetic field created by an infinite rectilinear conductor, on which the I current flows, is defined by the formula:

$$\vec{B} = \frac{\mu_0 I}{2\pi \rho^2} \vec{n} \times \vec{r}, \quad (1)$$

where $\mu_0 = 4\pi \cdot 10^{-7} \text{ ГН/М}$ – permeability of free space, \vec{n} – unit vector, sent along the direction of current, ρ – distance from the rectilinear conductor up to \vec{r} point, where the field is defined.

Choosing the beginning of the Cartesian coordinate system in any point of a rectilinear current directed along z axis, and two other x and y axes – perpendicular to the current, we will receive the equations of charged particle movement as follows:

$$\ddot{x} = -A \frac{x \dot{z}}{x^2 + y^2} - \frac{e B_0}{m} \dot{y}, \quad (2)$$

$$\ddot{y} = -A \frac{y \dot{z}}{x^2 + y^2} + \frac{e B_0}{m} \dot{x}, \quad (3)$$

$$\ddot{z} = A \frac{x \dot{x} + y \dot{y}}{x^2 + y^2}. \quad (4)$$

Here the constant, $A = \frac{\mu_0 e I}{2\pi m}$ has the dimension of speed, and its size depends linearly on current I ; the points designate differentiation on time t .

By numerical integration of the differential equations (2) – (4), the conditions have been found, at which the charged particle can be localized in the limited area of space. The opportunity of practical use of such devices is being discussed.

**APPLICATION OF HIGH-FREQUENCY SHORT-PULSED
PLASMA-IMMERSION ION IMPLANTATION OR DEPOSITION
METHOD FOR DIELECTRIC MATERIALS PROCESSING USING
GAS, METAL AND GAS - METAL PLASMA**

A.I. Ryabchikov, I.B. Stepanov, D.O. Sivin, A.I. Bumagina

*National research Tomsk Polytechnic University, 634050, Lenina 2, bldg. 4,
Tomsk, Russia, Phone (3822) 41-68-59, E-mail: ralex@tpu.ru*

A new approach in the development of advanced coating deposition and ion implantation method including an application of filtered dc metal plasma and high-frequency short-pulsed negative bias voltage with a duty factor in the range 10% - 99% are considered. The ion energy spectrum for different negative bias potential pulse duration (120 – 1100) ns was measured. The map of different methods of ion beam and plasma material treatment using high-frequency short pulse metal plasma immersion ion implantation or deposition depending on bias pulse duty factor and amplitude for Cu plasma is presented. The ion assisted coating deposition depending on samples conductivity and thickness, plasma concentration, pulse repetition rate and amplitude and duty factor has been examined.

**MODELING OF A SHIELDED INDUCTIVELY COUPLED PLASMA
SOURCE FOR ITS DESIGN OPTIMIZATION.**

A. A. Uvarov¹, S. E. Alexandrov²

¹ *Saint-Petersburg State Polytechnical University, Saint-Petersburg,
Russia, uvarov.andrew@gmail.com*

² *Saint-Petersburg State Polytechnical University, Saint-Petersburg,
Russia, salexandrov@ftim.spbstu.ru*

In this paper we report on the modeling study of certain features of a shielded inductively coupled plasma (ICP) source which may give an insight on design optimization of such sources.

The experimental 13.56 MHz ICP source was designed for 100 mm semiconductor wafer processing. Multislit Faraday shield was inserted between RF coil and plasma volume to prevent undesirable capacitive power

coupling. The plasma source performance estimation, which included ICP coil impedance, RF power losses and integral plasma parameters calculation, was done by finite element (FE) software for wide range of RF power levels and several Faraday shield geometries. Plasma modeling was based on Argon chemistry and a set of effective electron collision frequencies. To infer inductive power coupling coefficient, FE modeling was supplemented with analytical solution of air-core transformer problem where plasma acts as a single turn secondary winding. Applicability of the latter for the shielded ICP source study was evaluated by comparing absorbed in discharge RF power values, obtained with transformer model and FE modeling.

It was found out that air-core transformer formalism could be applied to the shielded ICP source analysis with reasonable accuracy. The obtained results showed that the inductive power coupling coefficient reached $\sim 0.5 \dots 0.6$ and RF power transfer efficiency could be as high as $\sim 90\%$ depending on the Faraday shield design. The performed study gave practical data on the source coil impedance variation and integral plasma parameters within source operation range.

POTENTIAL OF CERAMICS SURFACE AT PULSE ELECTRON IMPACT

Yu. G. Yushkov, A. V. Medovnik, E. M. Oks, V. A. Burdovitsin

*Tomsk State University of Control System and Radioelectronics,
40 Lenin str., Tomsk, 634055, Russia,
Phone: +7-(3822)-414712, Fax: +7-(3822)-513262, E-
mail: YuYushkov@sibmail.com*

We describe a plasma electron source designed to generate a pulsed electron beam in a wide-range of backing pressures (5-20 Pa). The source is based on a glow discharge with hollow cathode. With an accelerating voltage of 10 kV, current pulse duration 250 microseconds and a repetition frequency of 1 Hz electron beam current was 100 A. The achieved electron beam parameters and the peculiarities of the source in the fore-vacuum pressure range can effectively use it to modify the surface properties of insulating materials. Two different ways were used for measurement of the ceramics surface potential. It is shown that the potential of ceramics is negative, and its absolute value is much smaller than the energy of accelerated electrons. The factors

affecting the magnitude of the negative potential of non-conductive ceramic target were found. Based on numerical simulation analyzes the injected charge evolution was carried out. Structural changes in the surface layer of alumina ceramic irradiated by a pulsed electron beam are found. It is shown that the modification of surface properties of ceramics occurred due to the formation of domains within each grain consisting of densely packed and similarly oriented crystallites. The crystallites have an elongated shape. Their length and width are 0.5-1.5 microns and 0.1-0.2 correspondingly.

**EXPERIMENTAL STUDY ON A MICROWAVE PLASMATRON
WITH A HYDROCARBON-CONTAINING PLASMA-FORMING
MEDIUM**

A.G. Zherlitsyn, V.P. Shiyan, V.S. Kositsyn

*Institute of Physics and Technology at TPU, Tomsk, Russia, E-mail:
zherl@tpu.ru*

A great deal of attention has been given to a new technology for a deep processing of hydrocarbon. This technology uses plasma-chemical conversion of natural gas by means of a microwave plasmatron. The paper presents the experimental results of studies on a microwave plasmatron in which hydrocarbon gas is used as a plasma-forming medium. It was found that the presence of hydrocarbon gas in the plasma-forming medium leads to the formation of carbon, which violates the stable operation of the plasmatron, and may even stop its operation. The conditions for the maintenance of stable microwave discharge at atmospheric pressure in the hydrocarbon gas medium have been found. The results of studies on the plasmatron with an active system for discharge initiation are also presented [1].

The possibility of using a microwave plasmatron for the effective conversion (up to 70%) of natural gas into hydrogen and carbon nanomaterials, containing carbon nanotubes (70%) and amorphous carbon with a high specific surface area (up to 500 g/m²), are discussed.

This work was supported by the Federal Program "Scientific and scientific-pedagogical personnel of innovative Russia" for 2009-2013.

1. RF Patent № 2393988 Publ. 07/10/2010 Bull. № .19 // A.G.
 Zherlitsyn, V.V. Shiyan, Y.V. Medvedev, Y.D. Korolev, O.B. Frants. An apparatus for plasma-chemical conversion of hydrocarbon gas.

THERMAL EXPANSION OF ARTIFICIAL GRAPHITES IN THE TEMPERATURE RANGE OF 293-1650K

E.I.Zhmurikov¹, S.V.Stankus², O.S.Yatsuk²,L.B. Tecchio³

¹*Budker Institute of Nuclear Physics, 690090, Novosibirsk, SB RAS*

²*Kutateladze Institute of Thermal Physics, 690090, Novosibirsk, SB RAS*

³*Laboratori Nazionali di Legnaro - Istituto Nazionale di Fisica*

Nucleare, Legnaro, Italy

E-mail: evg.zhmurikov@gmail.com

The results of a thermal expansion investigation for MPG-6 and AXF-5Q graphites as well as ¹³C isotope-based carbon composite are presented. The measurements were carried out by the dilatometric method in the

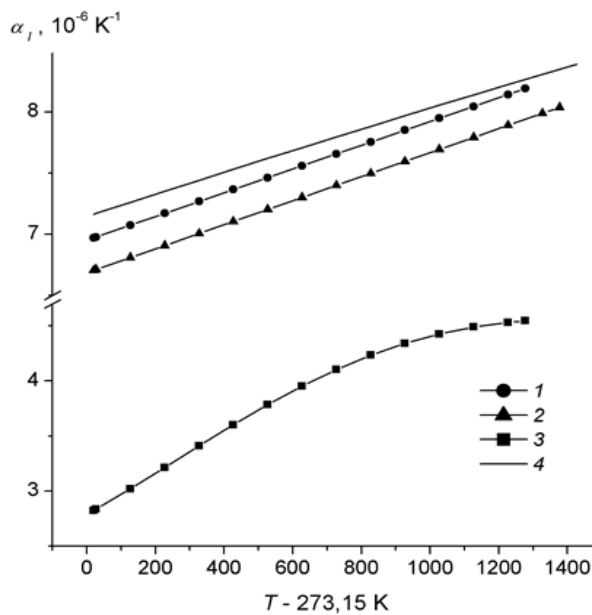

temperature range of 293-1650 K on the DIL-402C installation from NETZSCH (Germany) with a $(1-4) \times 10^{-7} \text{ K}^{-1}$ accuracy. Approximations for the dependences of the average integral coefficient of linear expansion on temperature were obtained; reference tables were calculated. The thermal expansion coefficient of ¹³C composite was substantially less than those of MPG-6 and AXF-5Q.

Fig.1. The average integral coefficient of graphite linear expansion. 1 - POCO AXF-5Q, 2 - MPG-6, 3 - ¹³C, 4 - POCO AXM-5Q [1].

The difference in the thermal expansion coefficient is determined by two competing factors: the thermal expansion of crystallites and the presence of pores, cracks and other structure irregularities, which may compensate the thermal expansion. Because of the high porosity of turbostratic carbon materials, their coefficients of linear and volumetric thermal expansion are always lower than those of single crystals or perfect polycrystals. In addition, the presence of a disordered amorphous phase among crystallites in the carbon material also reduces the coefficient of thermal expansion because the expansion of the amorphous phase is smaller than that of crystallites.

1. Touloukian Y.S., Kirby R.K., Taylor R.E., Lee T.Y.R. Thermal expansion nonmetallic solids // Thermophysical properties of matter. – 1977. – Vol. 13. – P. 75 – 78.

CONDITION BURNING FOR LAYER OF PLASMA CESIUM ARC WITH RECOMBINATION

V. P. Zimin

Tomsk Polytechnic University, Tomsk, Russia, zimin@ido.tpu.ru

Modification of materials by plasma flows requires knowledge of the processes occurring in the high-current arc discharges. One of the important factors of the existence and stability of these discharges is the condition of burning. In addition, the high-current discharges begin to play a considerable role of recombination processes. This report focuses on the study of combustion conditions in a cesium arc with recombination.

The boundary value problem for the diffusion of the plasma density, which describes the processes in low-voltage cesium arc discharge are analyzed. In the general formulation of the problem are taken into account the boundary conditions for the various jumps in potential at the plasma electrode. Generation function of positive charged ions Cs step ionization and three-body recombination.

Analysis of boundary-value problem in the phase plane density of the plasma – ion current previously allowed the author to obtain and investigate the transcendental equation for the condition of burning in the plasma layer, where recombination is negligible. In the limiting case for zero boundary

conditions, this expression coincides with condition of burning the arc obtained by W. Schottky.

For high-current arc modes of burning condition must be written taking into account the recombination. Analysis of the boundary value problem for the plasma layer is also done on the phase plane of the plasma density – the ion current. The peculiarity of this problem is the existence of a singular point of saddle type, which affects the type of configuration, the plasma density in the layer.

Transcendental equation for the condition burning of the arc, with recombination, in general, contains incomplete elliptic integral of the first kind. A transcendental equation for the condition burning of the arc, similar to the condition without recombination, in a limited range of plasma density to received.

The report presents the results and discussion of the investigation conditions of burning the arc with the recombination.

**INFLUENCE OF THE LOW ENERGY ION IRRADIATION
ON THE CONDUCTIVITY AND DOMAIN STRUCTURE
EVOLUTION IN LiNbO₃**

**D. O. Alikin¹, V.Ya. Shur¹, S.A. Negashev¹, V. I. Pryakhina¹,
A.V. Ievlev¹, P.S. Zelenovskiy¹, M.A. Dolbilov¹, N.V. Gavrilov²**

¹*Ferroelectric Laboratory, Ural Federal University, Ekaterinburg, Russia,
denis.alikin@labfer.usu.ru*

²*Charged-Particle Beams Laboratory, Institute of Electrophysics Ural
Branch of RAS, Ekaterinburg, Russia, gavrilov@iep.uran.ru*

We present the results of experimental study of the conductivity and polarization reversal in lithium niobate (LiNbO₃, LN) single crystals irradiated by low energy Ar⁺ ions. The studied samples represented Z-cut 0.5-1 mm LN plates congruent melting and doped by 5% of MgO. Irradiation by Ar ions was made to the Z⁺ polar surface by implantation with energy 40 keV and by plasma treatment with energies ranged from 1 to 5 keV. Low energy ion irradiation with flux about and fluence about not only amorphized the surface layer of crystals but led to sufficient heating of the samples up to 600-700°C.

It was shown that high irradiation heating leads to formation of the bulk layer with high conductivity. Formation of the layer was attributed to the out-diffusion of the oxygen due to annealing in vacuum [1]. Measurements of the surface conductivity dependence on the depth were made by two-probe method by repeated polishing of the crystal. It was shown that conductivity sufficiently increased in the layer with thickness from 100 μm to 1 mm with maximal value ranged from 10⁻¹¹ to 10⁻³ Ωm⁻¹ depending on the irradiation parameters. Blocking of the one side of the crystal by silver paint led to non-uniform change of the conductivity.

The domain structure evolution and switching current have been recorded during polarization reversal with electric field application using liquid electrodes. The static domain structure in the bulk has been visualized by optical microscopy and Raman confocal microscopy.

It was demonstrated great threshold field decrease (up to 100 V/mm) and several scenarios of unusual domain structure evolution. We have observed formation of the charged domain walls (CDW) with different geometry. In a case of the uniform conductivity modification it was revealed the self-assembled nanodomain patterns. In case of the non-uniform conductivity

modification it was revealed quasi-period structure of the CDW with period about 1.5 μm

All observed effects are caused by conductivity increase which leads to change of the depolarization field bulk screening mechanism and sufficient redistribution of the applied electric field in the modified crystal [2].

[1] E. Schreck, K. Dransfeld, *Appl. Phys. A. Solids and Surfaces***44**, 265, 1987.

[2] V.Ya. Shur et al, *Appl. Phys. Lett.* **77**, 3636, 2000.

The research was made possible in part by RFBR (Grants 10-02-96042-r-Ural-a, 10-02-00627-a, and 11-02-91066-CNRS-a); by Ministry of Education and Science (Contract 16.552.11.7020), by OPTEC, by UrFU development program (Grants №2.1.1.1/8, /9, /33)

MODELING OF RESIDUAL STRESS FORMATION IN METALLS AFTER IRRADIATION BY INTENSIVE ENERGY FLOWS

E. I. Bakin, V. S. Krasnikov¹, A. P. Yalovets²

South Ural State University, Chelyabinsk, Russia.

[*bakin.eugene@ya.ru*](mailto:bakin.eugene@ya.ru)

¹ *South Ural State University, Chelyabinsk, Russia.*

[*vas.krasnikov@gmail.com*](mailto:vas.krasnikov@gmail.com)

² *South Ural State University, Chelyabinsk, Russia.*

[*yalovets@physicon.susu.ac.ru*](mailto:yalovets@physicon.susu.ac.ru)

Target irradiation by electron, ion and laser beams of high energy density (10^5 - 10^8 W/cm²) allows to considerably improve the surface and volume qualities of the material. Release of beam energy in thin near-surface layer leads to formation of fast-varying temperature and stress fields. Parts of target could transit to liquid state. Residual stresses, generated during melt crystallization and further target cooling, determine performance properties of product, processed with energy beams.

Stress fields generated in target material under an influence of high energy beams depend not only on temperature fields, but also on surface relief. This fact should be of considerable importance for investigation of residual stress fields under micro-craters. This additional method of stress fields formation was confirmed by experiments where the traces of plastic deformation were found under micro-craters.

The point of this work is building a model for numerical investigation of residual stress fields after target irradiation and investigating its dependence on irradiation conditions.

In current work the residual stress fields formation has been modelled in 2-D cylindrical geometry, taking elastic-plastic flows into account. Plastic flow is modelled using von-Mises yield criterion.

Numerical calculation results have been obtained for both sub-critical (relief smoothing) and super-critical (micro-craters formation) irradiation conditions.

SOLID SURFACE EROSION PROPERTIES UNDER THE ACTION OF POWERFUL CHARGED PARTICLE BEAMS

G.A. Bleykher, V.P. Krivobokov

*Institute of Physics and Technology, TomskPolytechnicUniversity,
Tomsk, Russia, bga@tpu.ru*

Lately the experimental and theoretical researches reveals that the powerful pulsed charged particle beams with power density higher than $10^6..10^7$ W/cm² and particle initial energy of 10..1000 keV are able to generate intense erosion on a solid surface. At that its nature differs fundamentally from the nature of collision spattering which is produced by low-current ion beams of continuous action. Here removing of substance from the irradiated surface is induced due to intense radiation heating which results in origin of the phase transformations including evaporation.

This phenomenon is of interest of the researchers and technologists who deal with modifying of the solid surface properties, production of the functional materials and so on. But there are some difficulties in its practical use, because many properties of it are not clearly understood.

In this work the regularities of the solid surface erosion, mainly on the example of metals, are received on the base of numerical modeling. The erosion factor, the share of beam energy consumed for erosion and the beam energy expended for removing of one atom are regarded.

The roles of particles nature, their initial energy, beam power and energy density, pulse duration in the erosion properties are investigated. The substance properties, which influence strongly the intensity of atoms removal

from the surface, are revealed. The surface erosion features of the multi-layer targets are discovered.

The received results gave an opportunity to compare and systematize the beams on their ability to produce the surface erosion of various materials. They give understanding in which ranges of beam parameters the substance removal takes place with the greatest intensity and energy efficiency.

THE INFLUENCE OF RELAXATION PROCESSES ON EFFECTIVENESS OF PARTS SURFACE TREATMENT WITH INTENSE PULSED ELECTRON BEAMS

V.A. Shulov¹, O.A. Bytzenko², A.N. Gromov², D. A. Teryaev¹, V. I. Engelko³, K.I. Tkachenko³

¹*Moscow Aviation Institute, 4 Volokolamskoye shosse, A-80, GSP-3, Moscow 125993, Russia, E-mail: teryaev@mail.ru*

²*Chernyshev machine-building enterprise, 7 Vishnevaya street, 125362 Moscow, Russia, E-mail: teryaev@mail.ru*

³*Efremov Institute of Electro-physical Apparatus, 1 Sovietsky Avenue, Metallostroy, St. Peterburg 189631, Russia, E-mail: engelko@niiefa.spb.ru*

This paper reviews the experimental data on influence of preliminary mechanical treatment on physical-chemical condition of superficial layers of gas turbine engine compressor blades made of refractory $\alpha+\beta$ -titanium VT8 and VT9 alloys irradiated with intense pulsed electron beams. It is established that the degree of preliminary plastic deformation has decisive influence on thickness of recrystallized layer formed during irradiation of targets with intense pulsed electron beams.

**FEATURES OF THE PROCESS OF SELF-PROPAGATING
HIGH-TEMPERATURE SYNTHESIS, A STRUCTURE
AND STRONG PROPERTIES OF BORIDES IRON LAYERS
ON THE CARBONACEOUS STEEL 3, GENERATED UNDER
A POWERFUL ELECTRON BEAM IN VACUUM**

D.E.Dashev, N.N.Smirnyagina

*Institute of Physical Material Science SB RAS, Ulan-Ude, Russia,
fokter@mail.ru*

In the report the new method of electron beam boriding¹ which consists in influence of an electron beam on boron compound sating daub in vacuum is discussed. Application of high concentration energy source allows transferring very quickly energy of an electron beam at its impact with a surface of processed metal or an alloy, to heat up a zone of contact to very heats. It promotes increase in boron diffusion from sating daub on a surface and its penetration into metal volume, interaction and iron borides formation. The boride layer thickness depends on structure of the boron component. Layers thickness 300-360 microns are received by use of amorphous boron, and thickness 100-150 microns - boron carbide. The layers thickness made 200-280 microns (Fe₂B), 50-80 microns (FeB).

In the present work attempt of formation of layers on a basis of borides Fe₂B and FeB in the course of self-propagating high-temperature synthesis (SHS), initiated by an electron beam in reactionary mixes with participation Fe₂O₃, B and C on a surface of a steel 45 and further electron beam fasing of products is made. For this purpose took a mix of initial components in the ratio Fe₂O₃: 3B: 3C (Fe₂B) and Fe₂O₃: 2B: 3C (FeB), carefully frayed in an agate mortar, mixed with organic binding and reactionary daub put on a surface of the sample of a steel 45. Electron beam treatment was carried out in vacuum not above 2×10^{-3} Pa at capacity of electron beam 250-450 W during 1-3 minutes.

Microstructures of borides layers generated in the various ways are compared. The rounds off engagements are primary crystals of borides that answers entropic criterion of stability of the crystals limited form at the crystallization in conditions, approached to equilibrium. In turn, the boride round form determine the form of eutectic crystals.

It is established, that layers on the basis of borides Fe₂B and FeB (SHS) possess the least deterioration in conditions of dry friction. The layers thickness made 200-280 microns (Fe₂B), 50-80 microns (FeB). The microstructure

of a Fe₂B layer is complex, includes primary crystals of boride, dendrite inclusions, and eutectic. According x-ray analysis, the dendrite inclusions are the B-doped ferrite (boron solid solution into α -Fe).

During formation of a layer by electron beam boriding the evaporation of boron oxides is observed. Therefore to prevention of a deviation of a reactionary mixture from the stoichiometrical composition we applied a blanket of amorphous powder of boron oxide.

Application of a boron oxide layer by amorphous powder of the boron oxide promoted reception of the equilibrium borides coating. In all layers we observed eutectic having microhardness 650-700 HV. The round and extended inclusions had the ordered arrangement in a layer, their microhardness was 1600 and 1850 HV (FeB layers), and 1550, 1750 HV (FeB+B₂O₃ layers), accordingly. The round inclusions were only in Fe₂B layers (2000 HV) and Fe₂B+B₂O₃ (2100 HV).

According to x-ray analysis, the layers are mainly consisted from borides Fe₂B or FeB.

Reference

1. Semenov A.P., Sizov I.G., Smirnyagina N.N., Korobkov N.V., Tselovalnikov B.I., Vandanov A.G. *Patent 2186872 RU*, 2000.

The work is supported by the Russian Foundation for Basic Research (project, 10-08-00918a).

MODELING OF INITIAL STAGE OF ION IMPLANTATION PROCESS. ISOTHERMAL APPROXIMATION

E. S. Ilina¹, A. G. Knyazeva²V. N. Demidov³

^{1,2,3}*NR TPU, Tomsk, Russia,*

¹*Linasergg@mail.ru*

²*anna-knyazeva@mail.ru*

³*vn_demidov@mail.ru*

Now ion implantation methods are widely used for modification of materials. These methods are difficult and expensive. The ion implantation process is accompanied by different physical and chemical factors interacting between each other and influencing on the formed macroscopic properties of working materials. In experiment, the role of each factor doesn't was de-

tailed. That is why the mathematical modeling has a big significance for this researching.

The main purpose of this work consists in the investigation of initial stage of ion implantation process under isothermal approximation.

Under conditions of ion treatment of surfaces of materials, the insertion of particles into the surface layer is accompanied by a dynamic impact on the surface: impact of particles on the surface leads to the generation in the surface layer of waves of mechanical perturbations. In the case of low-energy fluxes, temperature changes are small, so that in first approximation, the process of ion implantation can be considered as isothermal, and the emerging mechanical stresses - elastic. Then, to describe the interaction of concentration and mechanical fields, we need the continuity equation, the equation of motion and mass balance equation for the components (implemented and contained in the original material).

The initial stage of the process of ion implantation in the isothermal approximation is investigated. As a result, the examples of concentration distribution were obtained at different moments, taking into account the effect of mechanical disturbance and coupling effect.

DISLOCATION DENSITY AND MICROHARDNESS CHANGE IN SURFACE LAYER OF IRON TARGET UNDER ION- AND ELECTRON-BEAM TREATMENT: NUMERICAL INVESTIGATION

V. S. Krasnikov, A. E. Mayer¹

South-Ural State University, Chelyabinsk, Russia, vas.krasnikov@gmail.com

¹ *Chelyabinsk State University, Chelyabinsk, Russia, mayer@csu.ru*

Today methods of surface modification with intensive charged particles beams are widely used for the improvement of target surface performance characteristics in medical, aircraft, automobile and reactor construction. The well-known results of beam treatment are increase of target hardness, increase of wear and corrosion resistance.

Intensive plastic deformation accompanied by the increase of dislocation density is one of the principal causes leading to improvement of material properties at electron and ion beam processing.

In this study we numerically investigate the electron and ion beam action on iron with continuum mechanics model directly accounting plastic de-

formations of the material by solving dynamic and kinetic equations for dislocations. As it will be shown in the given work, dislocation generation at typical technological irradiation modes occurs in the heat affected zone under the influence of thermo-stresses. The dislocation density in the surface layer of the target non-monotonically depends on the input energy density. Forming of two dislocation density maximums is connected with dislocation annealing in the zone subjected to melting. The generated shock wave becomes essential only when the enclosed energy excess some threshold value depending on particle energy, pulse duration and properties of the material.

THEORETICAL DESCRIPTION OF MULTIPLE SCATTERING PROCESSES IN THE ION BEAM BASED METHODS

A.I.Kul'ment'ev

*Institute of Applied Physics National Academy of Science of Ukraine, 58, Petropavlovskaya Str., 40030, Sumy, Ukraine,
E-mail: kulmentev@mail.ru*

Description of multiple scattering processes in the ion beam based methods is analyzed. Different existing approaches to this problem particularly in the RBS spectrometry are considered. In the framework of developed dynamical model set of computer experiments are carried out and both energy distribution of double scattering particles and probability of such processes are measured. Qualitative distinctions of those quantities in single scattering model and double scattering ones are analyzed. Theoretical description of multiple scattering processes in the ion beam based methods is developed and analytical results demonstrate good agreement with the data of computer experiments.

**MECHANISMS OF METAL SURFACE MODIFICATION UNDER
PROCESSING BY COMPRESSION PLASMA FLOWS**

A.Ya. Leyvi, M. Yu. Zotova, N.N. Cherenda¹, V.V. Uglov¹, A.P. Yalovets

¹*South-Ural State University, Physical Department, Lenina 76, Chelyabinsk
454080, Russia, e-mail: leyvy@mail.ru*

²*Belarusian State University, 4, Nezavisimosti ave., Minsk, 220030, Belarus
E-mail: Cherenda@bsu.by*

The treatment by intensive plasma flows with power density of $10^5 - 10^7$ W/cm² is one of the most important material processing problem which is widely used to improve physical and chemical surface properties. It results in material [hardening](#), roughness reducing, improving adhesion and mass transfer of substances for systems with covering; and also it is used for metal alloying.

The theoretical analysis of the surface state change mechanisms under the CPF (compression plasma flows) action is carried out. It has been shown that the essential factor for relief changing at CPF treatment is Kelvin-Helmholtz instability. The formation of large-scale wave-like surface with 200x1000 characteristic dimension disturbances is a result of Kelvin-Helmholtz instability development.

To describe the dynamics of the target surface under influence of plasma flow the system of continuum mechanics equations for two-phase flows (plasma-melt) was solved in two-dimensional axisymmetric geometry.

The calculation results of the target surface relief formation are given in comparison with the experimental data.

DEFORMATION BEHAVIOR AND SPALL FRACTURE OF Cu-Al-Ni ALLOYS WITH SUBMICROCRYSTALLINE AND COARSE-GRAIN STRUCTURE IRRADIATED WITH A NANOSECOND RELATIVISTIC HIGH-CURRENT ELECTRON BEAM

A. B. Markov¹, E.F. Dudarev², O.A. Kashin,³ A. E. Mayer⁴, E. V. Yakovlev¹, A. N. Tabachenko²

¹*Institute of High Current Electronics SB RAS, Tomsk, Russia,
almarl@lve.hcei.tsc.ru*

²*Siberian Physical Technical Institute at TomskStateUniversity,
Tomsk, Russia*

³*Institute of Strength Physics and Materials Science SB RAS, Tomsk, Russia*

⁴*ChelyabinskStateUniversity, Chelyabinsk, Russia*

The complex theoretical and experimental investigation of spall fracture of heterophase Cu-8,45%Al-5,06%Ni (% at.) alloy with submicrocrystalline and coarse-grain structure irradiated by a nanosecond relativistic high-current electron beam generated with SINUS-7 accelerator have been carried out. The specimens were disks made of this alloy with a coarse-grain recrystallized structure as well as with a submicrocrystalline structure formed with the many-side isothermal pressing technique.

The parameters of electron beam resulting in spall fracture of specimens up to 6 mm of the alloy with both submicrocrystalline and coarse-grain structure have been determined: electron energy 1.4 MeV, pulse duration 50 ns, and power density $\sim 1.6 \times 10^{10}$ W/cm². Predictions based on BETAIN 2 code calculations revealed that in the energy-release zone of Cu–Al–Ni alloy the temperature reaches the melting temperature and the formation of high pressure of amplitude of 12.5 GPa takes place. Further the formation of compressive travelling shock wave of amplitude of 8 GPa takes place which reflection from the rear surface leads to its transformation into the tensile one and spall fracture of the sample.

The grain structure at various distances from the place of spall fracture and the mechanism of fracture of alloy with both submicrocrystalline and coarse-grain structure have been investigated. It has been revealed that for coarse-grain structures near the spall crack the structure refinement takes place. The mechanism of alloy fracture at dynamic loading is ductile with the ductile dimple breakoff for both structures. Fracture surface on the mesoscale level contains the crests and troughs which evidences on the non-plane front of tensile wave travelling from the rear surface into the target bulk. The char-

acteristics of spall fracture of heterophase alloys Cu–Al–Ni and Al–Mg–Li–Zr with submicrocrystalline structure were revealed.

**PHASE TRANSFORMATIONS IN BINARY “METAL-SILICON”
SYSTEMS UNDER THE ACTION OF DENSE COMPRESSION
PLASMA**

Yu. A. Petukhou, N.T. Kvasov, V.V. Uglov¹, V.M. Astashynski², A.M. Kuzmitski²

Belarusian State University of Informatics and Radioelectronics, Minsk, Belarus, spadar_pett@tut.by

¹ *Belarusian State University, Minsk, Belarus, uglov@bsu.by*

² *B.I. Stepanov Institute of Physics, National Academy of Sciences of Belarus, Minsk, Belarus, ast@imaph.bas-net.by*

Application of compression plasma flows (CPF) as an effective instrument the production of unique semiconductor-based materials is a problem of a particular interest. One of the research direction in this area is the formation of novel binary and multicomponent composites with controlled electrical, magnetic and optical parameters. Physical properties and potential applications of surface silicon-based composites formed by CPF action depend significantly on their phase composition (for example, electrical properties of metal silicides are determined by metal and silicon ratio: metal-rich silicides usually possess metallic behavior (Fe₃Si, FeSi, Mo₅Si₃, NiSi etc.) while there is a number of semiconducting disilicides (β-FeSi₂, CaSi₂, CrSi₂, MoSi₂ etc.)). In the present work phase transformations in “metal layer-silicon substrate” systems (Fe/Si, Ti/Si, Cr/Si and Mo/Si) treated by dense compression plasma flows with power density $W=0,6-1,3$ GW/m² and pulse duration ~100 μs are studied by X-ray diffraction and discussed in terms of kinetic and thermodynamic regularities.

In Ti/Si system CPF action with $W=0,6-1,2$ GW/m² results in the formation of silicides Ti₅Si₃ and TiSi₂ (both C54 and C49 modifications). Ti₅Si₃ is primary phase, C49-TiSi₂ silicide is formed only for $W=0,6-0,8$ GW/m² but CPF treatment by three pulses increases it's molar concentration up to 9,6 mol.%. In Mo/Si system CPF-treated surface layer ($W>0,6$ GW/m²) contains β-MoSi₂ (primary phase) and Mo₅Si₃. The action of three CPF pulses results

in the formation of low-temperature tetragonal α - MoSi_2 . CPF treatment of Zr/Si system ($W=0,5-0,8 \text{ GW/m}^2$) leads to phase transition of Zr to high-temperature cubic β -Zr and formation of disilicide ZrSi_2 . Average concentration of β -Zr is about 0,07 mol.% for $W=0,5 \text{ GW/m}^2$, and decreases with power density growth. Phase formation for CPF action with $W=0,5-0,8 \text{ GW/m}^2$ is mainly controlled by contact melting at “metal-silicon” and “silicide-silicon” interfaces, diffusion in the surface melt, self-diffusion of silicon and metal to the interfacial region and rapid solidification ($\sim 10^7 \text{ K/m}$).

Increase of CPF power density over $0,8 \text{ GW/m}^2$ slightly changes phase composition of the modified layer. In Zr/Si, Cr/Si and Fe/Si binary systems the formation of disilicides ZrSi_2 , CrSi_2 and tetragonal α - FeSi_2 . Peculiarities of phase formation for these modes were studied by the calculation of non-equilibrium liquidus curves on phase diagrams taking into account heterogeneous solidification of silicides on solid silicon and gradient of chemical potential at solid-liquid interface. Calculations showed that silicide formation under the action of plasma flows is mainly controlled by heat transfer between solid silicon and silicide nuclei.

ELEMENTAL COMPOSITION OF SURFACE LAYERS OF “METAL-ON-SILICON” SYSTEMS TREATED BY LOW-ENERGY HIGH-CURRENT ELECTRON BEAMS

**N.N. Koval, Yu.F. Ivanov, V.V. Uglov¹, Yu. A. Petukhou²,
A.D. Teresov, A.V. Kalin¹**

*Institute of High Current Electronics of SB RAS, Tomsk, Russia,
koval@opee.hcei.tsc.ru*

¹ *Belarusian State University, Minsk, Belarus, uglov@bsu.by*

² *Belarusian State University of Informatics and Radioelectronics, Minsk,
Belarus, spadar_pett@tut.by*

The action of low-energy high-current electron beams (LEHCEB) with energy density $Q=8-15 \text{ J/cm}^2$, pulse duration 50-200 μs was applied for the formation of metal silicides in “metal layer (Cr, Ti, Zr)-silicon substrate” system. Refractory metal silicides are commonly used as interconnections in microelectronics and studied as catalysts for nanostructures growth and candidate materials for refractory neutron reflectors and fuel cell components in gas-cooled nuclear reactors.

Redistribution of metal and silicon in the surface layer was studied by scanning electron microscopy (SEM) and energy-dispersive X-ray microanalysis (EDX) and simulated by solving the equations of heat and mass transfer. Since LEHCEB energy density is sufficient for melting of the surface layer, numerical simulations were performed with taking into account contact melting at the interface, absorption and release of latent heat. The latter point was realized by transformation of temperature fields based on the heat balance between melting process and pre-calculated heating over the melting point.

EDX and SEM studies of LEHCED-treated Cr/Si, Ti/Si and Zr/Si systems revealed the formation of intermixed layer with 0,5-1,0 μm thickness at the “metal-silicon” interface. Results of numerical simulations showed that it is caused by contact melting when low-temperature eutectic melting point is reached. In this layer mass transfer is controlled by diffusion of liquid metal and silicon and their self-diffusion to the interface. Calculated heating rate is $\sim 10^7$ K/s, typical velocity of liquid-solid interface is $0,2 \cdot 10^{-2}$ - $3,9 \cdot 10^{-1}$ m/s, temperature gradient is $\sim 10^7$ K/m. Increase of LEHCEB energy density over 10 J/cm^2 results in the formation of deep metal-alloyed layer of silicon (10-20 μm thickness) with metal concentration 10-15 at.%. Intermixed layer contains metal-rich regions (C_{Me} is 28-39 at.%) distributed throughout it and surrounded by dendrites with 1-3 μm length. The formation of this layer is caused by convective mass transfer due to high temperature gradient, microscopic non-uniformity of energy distribution in the electron beam. Since viscosity of the diffusive layer is higher than that of the silicon-rich melt, unfused metal and surrounding intermixed shell are carried along the convection current. The formation of metal-rich dendrites is caused by solidification in negative temperature gradient at “liquid-solid” interface due to convective heat transfer in the surface melt.

This work is supported by Russian Foundation for Fundamental Research and Belarusian Republican Foundation for Fundamental Research (project F12R-017)

**CALCULATION OF STRESS FIELDS IN COMPOSITE AT
INFLUENCE OF THE HIGH-CURRENT ELECTRONIC BEAM**

V. V. Pogorelko, A. P. Yalovets¹

*South Ural State University, Chelyabinsk, Russia. vik_ko83@mail.ru
1South Ural State University, Chelyabinsk, Russia. sia.yalovets@physicon.susu.ac.ru*

Interest to examination of composites is caused, first of all, by their wide practical application. Now intensive loading of the homogeneous mediums is detailed studied experimentally as well as theoretically. Theoretical examinations of an intensive loading of composites are restricted by difficulties of application of the heterogeneous mediums models developed for today to the solution of these problems.

The purpose of this work is development of a composite material model and numerical modeling flows, which appear at influence on composite of powerful charged particle beams.

The system of equations for heterogeneous medium include the continuity equation, a motion and an internal energy equations for everyone components which have the universal appearance for any heterogeneous medium. The given system is closed by the equations featuring a components relaxation to an equilibrium state. The view of these equations is spotted by concrete structure of heterogeneous medium. To calculate of energy release function in irradiated medium the kinetics equation of fast particles is solved. In the given work the heterogeneous medium (a matrix with spherical inclusions) is investigated.

The role of composite components at stress and temperature fields' formation in an irradiated target is researched.

MEASUREMENT OF PRE-BREAKDOWN CURRENT IN ALKALI-HALIDE MONOCRYSTALS UNDER NANOSECOND PULSED VOLTAGE CONDITIONS**I. F. Punanov, R. V. Emlin, V. D. Kulikov¹, S. O. Cholakh²***Institute of Electrophysics UB RAS, Yekaterinburg, Russia, ifd@iep.uran.ru**1 Tomsk Argicultural Institute, Tomsk, Russia, vdkulikov@rambler.ru**2 Ural Federal University, Yekaterinburg, Russia, ilya@dpt.ustu.ru*

Pre-breakdown currents in crystallographically oriented breakdown channels initiated from positive needle in alkali-halide monocrystals KCl, KBr, NaCl, and LiF subjected to pulses of voltage up to 140 kV with duration of 8 ns and rise time less than 0.5 ns were defined. It has been shown that for KCl and KBr pre-breakdown currents are in the range 5 - 10 A. Average velocities of breakdown channel propagation are $8.0 \cdot 10^7$ and $3.5 \cdot 10^7$ cm/s for KCl and KBr respectively. Diameters of uncompleted breakdown channels have been observed as 0.10 mm in KCl and 0.20 mm in KBr. There is a inverse relationship between breakdown channel velocity and diameter of channels in these particular materials. At higher voltages and shorter rise times pre-breakdown currents are more intensive. The formation of breakdown channel in ionic crystals is considered.

PREDICTION OF TEMPERATURE FIELDS IN STAINLESS STEEL AND NITI TARGETS CONTAINING INCLUSIONS IRRADIATED BY A LOW-ENERGY HIGH CURRENT PULSED ELECTRON BEAM**D. A. Shepel, A. B. Markov***Institute of High Current Electronics SB RAS, Tomsk, Russia,**DAShepel@lve.hcei.tsc.ru*

This work is devoted to calculation of the temperature fields induced in targets of stainless steel 316L and NiTi irradiated by a low-energy high current electron beam (LEHCEB). Materials of the targets weren't homogeneous but contained inclusions. The inclusions for materials of SS 316L and NiTi were MnS and NiTi₂, respectively. The temperature fields were obtained by a numerical solution of nonlinear nonstationary heat conduction equation taking into account melting and crystallization processes. For numerical solution

is has been a used finite-difference scheme. Parameters of LEHCEB are chosen to be according to initial melting regime (pulse duration is 4 μs , energy of electrons is 30 keV, current density is 167 kA/m^2 for NiTi, 250 kA/m^2 for SS 316L). It was supposed that the parameters of LEHCPEB are the same during the processing. The analysis of the results received by the calculation shows that due to the presence of inclusion on irradiation surface the distribution of temperature is nonuniform. The extent of temperature non-uniformity (overheating) is determined by the difference between the maximal temperature attainable at the center of irradiation inclusion and that at the periphery of target where the inclusions are absent. It was obtained that the overheating in the SS 316L target is substantially by one order of magnitude larger than that in NiTi target. The thickness of heated layer is about 15 μm in all cases. The thickness of the melt occurring on the surface was about 1 μm whereas lifetimes of melt for these materials are different. For SS 316L and NiTi the latter equals 8 and 3 μs , respectively. All the mentioned above is being explained by the relation of thermal properties of matrix material and material of inclusion for each type of targets.

**THERMODYNAMIC MODELING OF BORIDES AND CARBIDES
TUNGSTEN FORMATION, SELF-EXTENDING HIGH-TEMPERATURE
SYNTHESIS, STRUCTURE AND PHASE COMPOSITION OF
 W_2B_5 AND WC LAYERS, GENERATED AT ELECTRON BEAM
PROCESSING IN VACUUM**

N.N.Smirnyagina^{1,2}, V.M. Khaltanova^{1,2}, T.B.Kim², A.S.Milonov

*¹-Institute of Physical Material Science SB RAS, Ulan-Ude, Russia,
kaltanovavm@mail.ru*

²-Buryat State University, Ulan-Ude, Russia

Electron beam technologies take a visible place among essentially new technologies which are subject to wide introduction in a national economy. By optimization and working off of technology electron beam boriding (saturation of a surface by a boron) it is very important not only carrying out of experimental works, but also numerical modeling of process of formation of boride coatings as it precedes experiments and allows to reduce time and means at a choice of modes of reception of layers with the maximum func-

tional properties. Use of thermodynamic calculations for a balance condition allows to model the phase transformations proceeding at synthesis borides and carbides and to choose formation conditions (temperature, pressure), boron components taking into account the least power expenses.

Thermodynamic modeling is executed under programs the ASTRA 4/pc and TERRA. Calculations are used up in a temperature interval 273 - 3873 K for the general pressure in system in a range 10^5 - 10^{-4} Pa.

In the report conditions of formation of carbides MoC, Mo₂C, WC, W₂C are discussed.

For example, interaction of oxide WO₃ with carbon proceeds difficult, through a formation stage oxide WO₂, which temperature of formation decreases with 793 K (10^5 Pa) to 393 K (10^{-3} Pa). The temperature of the beginning of formation WC also decreases with 853 K (10^5 Pa) to 473 K (10^{-3} Pa). Feature of phase's formation is presence of the diphasе area containing carbide WC and a quantity of carbon. Last is installed gas as a result of interaction with oxide CO₂ at the expense of formation carbon oxide CO. Decrease in the general pressure in system leads to decrease in a temperature interval with 853-2533 K to 473-953 K. Necessary that reduce in temperature stability of carbide WC in the presence of the gas environment containing oxide CO and CO₂ is observed. It opens possibility of reception of layers of carbide WC on a surface of carbonaceous steels in vacuum ($<10^{-2}$ Pa) for their superficial hardening.

In the present work attempt of layers formation on a basis boride W₂B₅ and carbide WC in the course of self-extending high-temperature synthesis (SHS), initiated by an electron beam in reactionary mixes with participation WO₃, B and C on a surface of a steel 45 and further electron beam fusing products is made. Electron beam processing spent in vacuum not above $2 \cdot 10^{-3}$ Pa at capacity of electron beam 250-450 W within 1-3 minutes

The thickness borides layers made 200-280 microns (W₂B₅) and 50-80 microns (WC). Microstructures of layers on the carbonaceous steel 45, generated of various reactionary mixes are compared.

The work is supported by the Russian Foundation for Basic Research (project, 10-08-00918a) and the thematic plan BSU 2012.

COMPUTER SIMULATION OF SPECTRAL-KINETIC CHARACTERISTICS IN NANOSTRUCTURED ALUMINA UNDER PULSED ELECTRON BEAM EXCITATION

T. V. Spiridonova, V. S. Kortov, S. V. Zvonarev

Ural Federal University named after the first President of Russia B.N. Yeltsin, Ekaterinburg, Russia, forSpiridonova@gmail.com

Pulsed cathodoluminescence (PCL) of dielectric materials can be employed to analyze them as well as to obtain important information on luminescence centers nature. Regarding optoelectronics development, this phenomenon can be used in design of new optoelectronic devices. Al_2O_3 is of special interest for cathodoluminescence research.

The aim of this paper is computer simulation of luminescence spectra and CL decay kinetics under pulsed electron beam excitation in anion-defective single-crystals and nanostructured $\alpha\text{-Al}_2\text{O}_3$ samples.

In the process of CL excitation, the primary electron coming from electron gun enters dielectric. While doing so, it gives its energy for ionization to form electron-hole pairs. Further on, electrons and holes can recombine giving energy to luminescence centers. This results in center excitation in the specific spectral region. Taking into account the described processes, the physical model for PCL parameter calculations consists of the following main stages:

1. Electron-hole pair generation and their quasiequilibrium concentration definition.
2. Charge-carrier recombination accompanied by intracenter transition excitation and PCL luminescence region formation.
3. Intracenter luminescence decay after pulsed electron beam.

On the basis of the described physical model, algorithm and program for PCL parameters calculations in solid single-crystal and nanoscale dielectrics have been developed. Computer simulation was performed at pulse duration of 1 ns, incident electron energy of 130 keV, and current density of 60 A/cm². Luminescence spectra of F- and F⁺-centers as well as PCL decay kinetics in single-crystal and nanoscale alumina at particle size change were calculated. It was shown that luminescence region broadening depending on particle size was observed in nanostructured alumina.

When particle size decreases, F-center luminescence decay time in nanostructured $\alpha\text{-Al}_2\text{O}_3$ under pulsed electron-beam excitation is reduced to submicrosecond as compared to the relative value in single-crystal sample

(millisecond relaxation time range). At the same time, when particle size changes from 50 nm to 20 nm, decay time grows, but when the particle size is further reduced to 5 nm, it decreases. Decay time increase is caused by relaxation time growth due to electron-photon interaction weakening. Then, due to electron scattering increase on the particle surface and their size reduction, electron relaxation rate grows and PCL decay time decreases.

Calculated data are in good agreement with experimental data.

ATOMISTIC SIMULATION OF SWIFT HEAVY ION-INDUCED MODIFICATION AND TRACK FORMATION IN NUCLEAR MA- TERIALS

S. V. Starikov, V. V. Pisarevd

*Joint Institute for High Temperatures of RAS, Moscow, Russia,
starikov@ihed.ras.ru*

Nuclear Safety Institute, Moscow, Russia

At moving of the swift heavy ion (e.g. Xe ion - the typical fission fragment), the track formation frequently takes place in nuclear materials. There is a large interest in understanding of the mechanisms of track formation. The swift ion interacts mainly with electron subsystem (at high kinetic energy). Therefore, the initial state of the system at track formation is two-temperature and the electron temperature may be several orders higher than the ion one. One of the main theoretical difficulties for construction of a model is the fact that the electron-ion relaxation time is comparable to the time-scale of the studied process and the accompanying phenomena (heat transfer, phase transitions etc.) Therefore, the direct simulation of two-temperature stage is necessary for correct description

In this work, the atomistic simulation of track formation of swift heavy ion in nuclear materials (U, Mo, UO₂) is performed. The two-temperature atomistic model with explicit account of electron pressure and electron thermal conductivity is used. This two-temperature model describes ionic subsystem by means of molecular dynamics while the electron subsystem is considered in the continuum approach. The various mechanisms of destruction of the crystal during the track formation are examined. In U and Mo, the track forms as the large accumulation of defects. It is agreed with the concept of

tracks formation in metals. The comparison to the experimental data is performed.

**QUANTUM-MECHANICAL CALCULATION OF THE
INTERMEDIATE PRODUCTS OF RADIOLYSIS
OF POTASSIUM PICRATE**

D. G. Yakubik, V. Kh. Pak

*Kemerovo State University, Kemerovo, Russia
pak@kemsu.ru*

Calculations of possible intermediate products of radiolysis of potassium picrate by Hartree-Fock and density functional theory methods are performed. The calculation results are compared with available experimental data.

**MODIFICATION OF THE STRUCTURAL-PHASE STATE OF
FERRITIC-MARTENSITIC STEELS BY HIGH-TEMPERATURE
PULSED PLASMA FLOWS**

**V.L. Yakushin, P.S. Dzhumaev, B.A. Kalin, Aung Thurein Hein,
M.G. Isaenkova, M.V. Leontyeva-Smirnova¹, V.I. Polsky,
Yu.A. Perlovich, O.V. Emelyanova and I.A. Naumenko¹**

*National Research Nuclear University «MEPhI», Moscow, Russia
vlyakushin@mephi.ru*

¹*Academician A.A. Bochvar High-Tech Research Institute
of Inorganic Materials, Moscow, Russia*

The ferritic-martensitic steels are considered as prospective materials for the fuel element claddings and fuel assemblies of the fast neutron reactors. The work presents the results of an experimental study of the influence of a treatment by pulsed plasma flows on the structural-phase state (SPHS) and the strengthening of the surface layers of fuel tubes made from chromium ferritic-martensitic steels. The samples used for the investigation were made

of the standard fuel tubes 6.9 mm in diameter (with a wall thickness of 0.4–0.5 mm) of chromium (12 wt.% of Cr) steels: ChS139 (20Cr12NiMoWNbVB), EK181 (16Cr12W2VTaB), EP823 (16Cr12MoWSiVNbB) and EP900 (16Cr12MoWSiNbVCeNB).

The surface of the fuel tube fragments was modified by helium and nitrogen plasma flows with a specific power of an incident flow changing in the range of 0.6–5.2 MW/cm² at a pulse duration of μ s. The number of irradiation pulses was changed from 2 to 10. The α 15–20 structural-phase state of the initial samples and samples treated by plasma flows was investigated by optical and scanning electron microscopy and by X-ray investigations using standard techniques. The microhardness of samples was measured by the method of Vickers using an indenter load of 0.5 N.

It has been found that the treatment of fuel tubes made of chromium steels by plasma flows with a specific power of ~ 1.0 MW/cm² ($N = 2$) leads to the surface melting. An increase in the power density of the plasma flows results in an intensive melting of the surface layers and formation of a developed relief after solidification.

The heating and subsequent high-speed cooling of the surface layers make it possible to fix a non-equilibrium (martensitic) structure of the investigated steels which differs by a large number of defects and, under certain conditions, even by a change of the crystal cell symmetry. A decrease of the crystal cell parameter determined by orientation of the initial grains relative to the radial direction or the direction of the plasma flow action has been revealed.

Melting processes, subsequent recrystallization and stresses occurring as a result of pulse treatment change the crystallographic texture of the surface layers of cladding tubes and cause an increase of the texture component {100} along the radial direction of tubes, the intensity of which increases with the plasma flow power density. At that, a two-dimensional nanocrystalline structure with a cross grain size less than 100 nm is formed in the surface layers.

It has been shown that the structural-phase changes that take place lead to the surface hardening (up to 20-30%), the degree of which depends on the treatment conditions.

PERFORMANCE OF ODS W UNDER TRANSIENT HIGH THERMAL LOAD

S. Yan, S. K. He, Y.Z. Zhu, B. Y. Zhang, J. M. Xue, Y. G. Wang

Institute of Heavy Ion Physics, State Key Laboratory of Nuclear Physics and Technology, Peking University, Beijing, 100871, China, Syan@pku.edu.cn

The oxide dispersion strengthened (ODS) tungsten alloy is one of the important candidates for plasma facing materials (PFM). This paper is mainly focus on testing the performance of a new W-based alloy W-0.5%Y₂O₃-1%Ti (WYT) and W-1wt%La₂O₃(WL10)under transient high heat load by means of intense pulsed ion beam (IPIB) irradiation. The ion species of the IPIB was Cⁿ⁺, the peak value of acceleration voltage was 235kV; the beam peak current intensity was 190A/cm²; the pulse duration was 80ns. Samples were irradiated with 1~50 pulses. The changes on surface morphology showed that the melting and ablation at oxide particles are more severe than at W matrix. EDX analysis verified thesevere ablation of oxides under the transient high thermal load brought by IPIB. The poor heat conductivity and lower melting point of oxides are counted for their preferential ablation. In addition, we also studied the response of helium pre-implanted WYT to the transient heat flux brought by IPIB. The experimental results show that the presence of He bubbles can greatly reduce the thermal conductivity, hinder the conduction of heat. As a result, the local overheating leads to more severe surface melting and ablation.

FRICIONAL PROPERTIES OF OXIDE FILMS OF LASER TREATMENT ZONE OF THE TOOL STEELS

S.I. Yaresko

Samara, Russia, scisec@fian.smr.ru

At a hardening of the metalcutting tool in air on the surface of the laser treatment zone the complex multicomponent structure is formed, in composition of which there are oxides of iron and alloying elements (Cr, Mo, W). The complex of properties of the oxide films has a significant effect on the

wear of tool. For definition of frictional properties of the oxide films, formed on surface of the laser treatment zone, modeling experiments on measurement of adhesive strength of the oxide films of laser processing zone of the tool materials were used in the present work.

I.V. Kragelskii's method based on measurement of a molecular component of coefficient of the friction was used for studying an adhesive shear strength τ_n of oxide films. The method is founded on the following an assumption: at contact of two solids under a compressive loading on the spots of contact an adhesive links are formed. These links are the result of act of the molecular forces of interaction surfaces of the contacting bodies.

The physical model which at a first approximation reflects the real conditions of a friction and wear in local contact is used for definition of parameters of the adhesiveness interacting in the presence of the movable contact. According to this model the sample in the form of the frustum of a cone (made of a tool steel) is put into the cylindrical sample (made of a structural steel). Then the loading is applied to the cone and the cylinder is rotating around its own axis, and the cone-shaped sample remains stationary.

The forces outlaid for rotation of the indenter are connected with shear strength of an adhesive links. The adhesiveness component of coefficient of friction is defined from expression: $f_M = \frac{\tau_n}{p_n}$, where p_n is the normal contact stresses acting on a surface of the indenter in the field of all contact. Experiments were carried out under contact of high-speed steel P18 (a cone material) and steel 20 (a cylinder material) in the conditions of a dry friction and a friction after a laser treatment of a cone on the regimes providing the formation of a stable oxide film in laser treatment zone ($\varepsilon=2.2 \text{ Дж/мм}^2$, double treatment). In experiment the size of normal contact stresses was $\sim 920 \text{ МПа}$. It was established that absence of laser treatment leads to value of coefficient of friction $f_M=0.35$, and the laser surfacing of a friction of a cone reduces coefficient of friction to value $f_M=0.28$, i.e. ensures its decrease approximately on 20%.

**NUMERICAL SIMULATION OF THE INTERACTION
BETWEEN HIGH INTENSE PULSED ION BEAM
AND Ti TARGET**

**Xiao Yu¹, Yang Li¹, Xiaoyun Le¹, Gaolong Zhang¹, Jie Zhang¹,
Jie Shen¹, Huaizhe Xu¹, Weijiang Zhao²**

¹*Beihang University, Beijing, 100191, China, zhangjie.jade@gmail.com*

²*Peking University, Beijing, 100871, China, wjzhao@pku.edu.cn*

The technology of Intense Pulsed Ion Beam from inertial confinement fusion technology (ICF) get more and more attention because of its wide application prospects in the material surface engineering and X-ray irradiation effect simulation, the effect of IPIB on matter is the high compression of energy on time and space (Pulse width of tens to hundreds of nanoseconds, power density 10⁶~10¹¹W/cm²), making great difficulty in real time experiment on IPIB by available technical conditions. And the computer simulation technology with the safety, high efficiency, low cost characteristics make computer numerical simulation method played an important role in the study IPIB.

Brief theory of the energy deposition within target material by IPIB was introduced in this essay, and the interaction between molten plasma and target material was described. Then under the basic assumption of numerical calculation, the hydrodynamics equation which coupled thermodynamics equation of three dimensions and its difference equation was established. At last the calculation program was made and studied.

We analyzed the thermal-mechanical effect of different energy ion beam irradiation of materials by numerical simulation in order to reveal the basic characteristics of the material generated by pulsed ion beam irradiation effects, and provide relevant theoretical basis for material modification of ion beam irradiation.

**THE MODIFICATION OF METALS AND ALLOYS PROCESSES
IN LOW-TEMPERATURE DISCHARGE PLASMA**

V. Abidzina, I. Tereshko, V. Red'ko

Belarusian-Russian University, Mogilev, Belarus, obidina@tut.by

The aim of this work is to investigate the volume modification of materials exposed to low-energy ion irradiation in glow-discharge plasma.

The subjects of the experimental investigation were armco-iron, high-speed steel, electrical copper, electrolytic nickel, stainless steel and hard alloy. Low-energy ion impact was carried out in a plasma generator. The ion energy was 1-3 keV, whereas the irradiation time varied from 15 to 90 minutes. After the low-temperature plasma treatment, microhardness of the irradiated materials, their fine dislocation structures and electrical resistivity were investigated.

In the framework of the present investigations of well annealed samples with initially small dislocation density (armco-Fe, etc) after irradiation in GDP, a high increase in dislocation density at the maximum at the depth of 6 mm as well as nanocluster formations have been observed. For materials with initially increased dislocation density (high-speed steel, etc.) reorganization of present dislocation structure has been the most considerable that consists of intensive formation of dislocation fragments or grinding of fragments with corresponding increase in their disorientation.

It had been shown earlier that after low-energy ion irradiation in glow discharge plasma (GDP) modification of materials was observed up to the depth of 10 mm from the irradiated surface. That result was described as a "long-range effect". This is actually a bulk modification.

As a result mechanical and physical properties (e.g. microhardness and electrical resistivity) of the irradiated materials have been changed considerably.

These peculiarities may hardly be explained by classical solid state physics. It has been shown that long-range and long-term modification of materials can be explained in the framework of nonlinear theory of crystal solids. We have been suggested a hypothesis based on the idea of nonlinear oscillation in crystals which lead to the active self-organizing processes in the ion subsystem of irradiated crystals. The computer simulation was used to investigate the interaction between low-energy ions and nonlinear crystal lattices. A molecular dynamics method has been applied to calculate the evolu-

tion of atom ensembles in lattices of different dimensions using the equations of classical dynamics.

We have shown that nonlinear oscillations became excited in the atomic chains of crystal lattices after low-energy ions irradiation and as a result of them the whole atoms became stabilized in new positions, which resulted in the formation and development of new metastable, but long-lived atomic groups (nanoclusters). In fact this provides the volume modification of the investigated materials.

Thus, low-energy ion irradiation of solids in GDP plasma leads to the formation of complex nanocrystalline structures in the irradiated volume. Nanostructures formations in steels and alloys after the irradiation lead to changes in physical and mechanical properties and may be used to develop new hardening technologies of metals and alloys.

INCREASED ULTRAVIOLET REFLECTIVITY OF MAGNETRON DEPOSITED Al FILMS

O.Kh. Asainov, S.P. Umnov

Tomsk Polytechnic University, Tomsk, Russia, usp@tpu.ru

Magnetron sputtering systems are widely used in deposition technology for coatings of different functionality.

Optical properties of aluminum coatings deposited by the original method have been investigated in this paper.

Film deposition was performed using the planar magnetron with aluminum cathode (99.995%) on the installation for magnetron coating deposition. Medium frequency supply source was used in the installation. The working gas was argon. The working pressure in the chamber upon sputtering was 0.15 Pa. The Hall-type source of Ar ions was used in a number of experiments.

The experimental technique was the following. One part of glass samples was deposited by aluminum films using a conventional method. The thickness was determined using AvaSpec USB2 spectrometer. Another part of samples was deposited also by aluminum films with the same thickness, but using the original method.

The reflection factor of obtained samples from glass was measured on SF-256 spectrophotometer. Photometric studies showed that samples with

film aluminum coatings have increased reflection factor in the ultraviolet area in comparison with the films that were deposited using a conventional method. In our opinion, the reason for the increased reflection factor can be due to the changes that occurred in the coating structure. Electron-microscopic studies (SM 12 , "Philips") and x-ray diffractometric studies (Shimadzu XRD6000,"Shimadzu") of deposited coatings have been performed to check this supposition.

DYNAMIC SIMULATION OF THE TEMPERATURE FIELD OF POLYCRYSTALLINE IRON UNDER THE ACTION OF COMPRESSION PLASMA FLOWS

V. V. Astashynski, N. N. Cherenda, S. O. Gluchko

Belarusian State University, Minsk, Belarus, astashynski@bsu.by

A search for new methods of materials processing is of great interest since the possibilities of traditional thermochemical methods are practically exhausted. The treatment of different materials with high-energy nitrogen-based compression plasma flows opens up new opportunities for modification of their surface characteristics aimed for obtaining layers unique in the structure, phase composition, and mechanical properties. Such treatment is performed with compression plasma flows generated by quasi-stationary plasma accelerators such as a magnetoplasma compressor. At the same time the most important influence on the structural and phase transformations in the modified layer material have encountered during the processing of high temperature gradients.

Previous investigation has shown that exposure of iron samples to compression plasma flows resulted in the formation of deep (up to 60 micrometers) modified layers consists of near-surface layer based on the nitrogen-rich phases followed by the zone of columnar phases. In the considered problem the main parameter was the distribution of the temperature in the depth of the sample and its dependence of impact parameters. However, the experimental determination of the dynamics of temperature fields with good spatial and temporal resolution is almost impossible. Therefore, numerical modeling can provide data that are difficult or impossible to obtain experimentally.

In the present model the transient temperature distribution in the sample is determined at the given initial and boundary conditions by taking into ac-

count the dependence of heat capacity and thermal conductivity of iron on the temperature. The energy density absorbed by the sample surface is about 15 J/cm^2 per pulse that under the test conditions corresponds to the flow power density of $1.5 \cdot 10^5 \text{ W/cm}^2$. When a plasma irradiates a iron, the surface layer within several μm is immediately heated above its melting point. Thereafter the melted region is cooled with a typical cooling rate of 10^6 – 10^8 K/s. The surface region then has non-equilibrium microstructures, such as amorphous and nanocrystalline phases, that have enhanced hardness and wear resistance.

In the numerical simulation was used a homogeneous model in which the boundaries of phase transitions is not specifically allocated. In addition, the model includes the solid–liquid and liquid–vapour transformations, which facilitate the calculation of the molten volumes and vaporized materials.

RADICAL PRODUCTE IN IRRADIATED CRYSTAL HYDRATE OF MAGNESIUM NITRATE

D. V. Balikov, V. Kh. Pak, M. B. Miklin, V. A. Nevostruev

Kemerovo State University, Kemerovo, Russia

pak@kemsu.ru

In this paper the experimental results of irradiation action on crystal hydrate of magnesium nitrate are presented for the first time. The composition and properties of paramagnetic centers which are formed in magnesium nitrate are investigated under irradiation at liquid nitrogen temperature. The efficiency of formation, the kinetics of accumulation, of paramagnetic centers and their thermal stability is examined. The formed radicals are identified.

VACUUM-PLASMA TECHNIQUES OF HIGH-QUALITY PRODUCT SURFACE TREATMENT

**D.P. Borisov, N.N. Koval^{1,2}, A.D. Korotaev¹, V.M. Kuznetsov¹,
V.Ya. Romanov¹, P.A. Terekhov¹, and E.V. Chulkov¹**

Tomsk State University, Tomsk, Russia, borengin@mail.ru

¹*Tomsk State University, Tomsk, Russia, dean@phys.tsu.ru*

²*Institute of High Current Electronics SB RAS, Tomsk, Russia,
koval@opee.hcei.tsc.ru*

A number of effective techniques for modification of product surface properties are presented, which rely on the application of new vacuum installations using arc-discharge plasmas. Possibilities of improving product surface properties, producing new composite surface structures, and developing promising technologies for surface treatment, based on the mechanisms of formation of low-pressure arc discharges and their application in solid surface treatment, are demonstrated.

INTERMETALLIC PHASES SYNTHESIS IN THE SURFACE LAYER OF AL-SI ALLOY BY COMPRESSION PLASMA FLOWS IMPACT

**N. N. Cherenda, N. V. Bibik, V. V. Uglov, V. M. Astashynski¹,
A. M. Kuzmitski¹**

Belarusian State University, Minsk, Belarus, cherenda@bsu.by

¹*B.I. Stepanov Institute of Physics of the National Academy of Sciences of
Belarus, Minsk, Belarus, ast@imaph.bas-net.by*

Treatment of “coating/substrate” system by high-power ($\geq 10^6$ W/cm²) laser, electron, ion and plasma beams is the prospective technique of materials alloying by coating elements. Change of the coating thickness and beam parameters allows to control element and phase composition of the alloyed surface layer. Such an approach was used for the synthesis of the composite surface layer with enhanced mechanical properties in Al-12%Si alloy used in automotive industry.

Titanium, zirconium and chromium were chosen for alloying. Coating of alloying element with different thickness (2-5 μ m) was formed by cathodic

arc vapour deposition. After that the samples were treated by compression plasma flows (CPF) generated by a gas discharge magnetoplasma accelerator of compact geometry. Comparatively long discharge duration ($\sim 100 \mu\text{s}$) and high energy delivered to the surface by CPF provided necessary conditions for the formation of deep ($> 20 \mu\text{m}$) alloyed layer. The density of energy absorbed by the surface was changed in the range of 12 J/cm^2 - 27 J/cm^2 . A variety of techniques including X-ray diffraction, Rutherford backscattering spectrometry, scanning electron microscopy, energy dispersive X-ray microanalysis etc. were used for the characterization of the surface layer.

The findings showed that plasma impact resulted in the formation of composite layer containing supersaturated aluminium solid solution and disperse intermetallic phases on the base of Al_3Ti , Al_7Cr and Al_3Zr . Formation of metastable phases such as tetragonal Al_3Zr was found. Size of intermetallic particles was dependent on treatment parameters and was changed in the range of 0.1 - $3.0 \mu\text{m}$. Silicon in contrast to the initial structure was homogeneously distributed along alloyed layer and took part in formation of supersaturated $\text{Al}(\text{Si})$ solid solution and intermetallic phases e.g. $(\text{Al},\text{Si})_3\text{Ti}$. Change of intermetallic phases morphology depending on treatment parameters was analyzed. Synthesized composite layer possessed high hardness value unusual for aluminium layers (up to 4 GPa). Main mechanisms of structure transformation during plasma impact are discussed.

REMOVAL OF OXIDE LAYERS FROM A STEEL SURFACE BY COMPRESSION PLASMA FLOWS

**N. N. Cherenda, V. V. Uglov, A. A. Smilgin, V. M. Astashynski¹,
A. M. Kuzmitski¹, G. E. Remnev²**

Belarusian State University, Minsk, Belarus, cherenda@bsu.by

¹*B.I. Stepanov Institute of Physics of the National Academy of Sciences of Belarus, Minsk, Belarus, ast@imaph.bas-net.by*

²*Tomsk Polytechnic University, Tomsk, Russia, remnev@epho.tpu.ru*

The impact of high power electron, ion and plasma beams with materials results in absorption of the beam energy by the surface due to ablation, rapid heating, etc. These processes can be applied for surface cleaning or removal of surface layers. The results of the investigation of the surface and cross-section morphology of construction carbon steel 3 with a surface oxide

layer after compression plasma flows treatment are presented in this work. The determination of the reasons for oxide layers removal during plasma impact was the main aim of the research carried out.

The oxide layer with the thickness of 27 μm was grown on steel 3 by annealing in air at 700°C for 3 hours. The oxide layer consists of two sublayers: Fe_3O_4 (upper) and Fe_2O_3 (bottom). The surface of oxidized samples was treated by compression plasma flows that were generated by a gas discharge magnetoplasma accelerator of compact geometry. The discharge duration was 100 μs , the number of pulses 1-3. The energy absorbed by the surface layer varied in the range of 10-20 J/cm^2 per pulse. The surface and cross-section of treated samples were analyzed by optical and scanning electron microscopy, X-ray diffraction and Rutherford backscattering spectrometry.

The findings showed that treatment with the total absorbed energy density of 40-60 J/cm^2 resulted in cleaning of the whole surface from the oxide layer. Evaporation of Fe_3O_4 and cracking of Fe_2O_3 sublayer due to the difference in coefficients of linear expansion are the main reasons for oxide layer removal. Treatment with the total absorbed energy density of 20-60 J/cm^2 additionally led to the formation of the modified steel layer with a dispersed submicron structure and thickness up to 26 μm .

MODIFICATION OF CHROME-VANADIUM WHITE IRON COATINGS BY IMPULSIVE ELECTRON-BEAM PROCESSING

B.V. Dampilon^{1,2}, V.G. Durakov¹

¹*Institute of Strength Physics and Materials Science, 2/4 Akademicheskii av., Tomsk, 634021, Russia*

²*National Research Tomsk Polytechnic University, 30 Lenina av., Tomsk, 634050, Russia*

dampilon@ispms.tsc.ru

Results of investigation of effect of impulsive electron-beam processing and following annealing on structure and the hardness of hardfaced chrome-vanadium white iron coatings are presented in present paper. The coatings were deposited on low carbon steel substrate by means of the method of electron-beam hardfacing in vacuum.

After grinding surfaces of the coatings were locally processed by impul-

sive focused electron beam with discrete point distribution in a square packing on the surface area. Each modified zone was obtained as a result of single impulse of the electron beam with the duration of 15 milliseconds. The diameter of each zone on the surface was about 500-600 μm , and the zone depth was equal to 400-500 μm . Modified zones were divided by interlayers of initial coating. These zones were formed through liquid phase. Material of coating in a zone of effect of impulsive electron beam is rapidly heated to the melting temperature and instantly crystallized as a result of intense heat abstraction to the volume of material. Local liquid hardening occurs as a result of such processing.

The research results showed that the modified zones consist of two phases. The first phase is supersaturated austenite. The second phase locally distributed in the volume of modified zone is the nucleation centers of eutectic. The measurements obtained by complex «NanoTest» showed that the material of the modified zones has low values of the hardness in comparison with initial coating material. The low hardness values are caused by presence of significant amount of supersaturated austenite in each modified zone. The subsequent high-temperature annealing of the specimens leads to a significant increase of the hardness of the modified zones. As a result of the annealing supersaturated austenite is decomposed on eutectoid with nanoscale structure components. Increasing of the annealing temperature up to 1100⁰C results in decomposition of supersaturated austenite, growth and coagulation of carbide phase in the modified zones. Probably, under increase of the annealing temperature reconstruction of carbides to equilibrium stoichiometric composition occurs with increase of their hardness. Increasing of amount of the equilibrium carbide phase and their uniform distribution leads to growth of the hardness of the modified zones.

**STRUCTURAL DAMAGE IN LiF CRYSTALS IRRADIATED
WITH FAST IONS**

**A.Dauletbekova, J.Maniks¹, I.Manika¹, A.Russakova², R.Zabels¹,
A.Akilbekov², M.Zdorovets³, A. Muhyshbayeva¹,
Z. Umatova¹, A. Zhumazhanova¹**

*L.N. Gumilyov Eurasian National University, Astana, Kazakhstan, al-
ma_dauletbek@mail.ru*

¹*ISSP University of Latvia, Riga, Latvia, manik@latnet.lv*

²*L.N. Gumilyov ENU, Astana, Kazakhstan, akilbekov_at@enu.kz*

³*Astana Branch of INP RK, Astana, Kazakhstan, mzdorovets@inbox.ru*

Structural defects and color centers were investigated in irradiated LiF crystals with 150 MeV Kr ions and 56 MeV Ar. For ion irradiation in the fluence range 10^{11} - 10^{14} ions/cm² a cyclotron accelerator DC-60 (Astana) was used (beam current 10nA/cm²). Color centers in LiF (F and F_n) were studied by UV-VIS spectroscopy. A saturation of F centers occurs at $\Phi \sim 10^{13}$ ions/cm².

The ion-induced structure modifications in LiF crystals on the irradiated surfaces and in bulk (cross-section of the sample) were investigated using scanning electron (JSM-7500F, JEOL) and atomic force microscopy. The structural modification was studied after a chemical etching in saturated aqueous FeCl₃ solution.

In LiF irradiated with 150 MeV Kr ions nanoscale defects with the size of 30-50 nm were observed after irradiation above the threshold fluence of 10^{12} ions/cm². The structural modifications include also ion-induced formation of dislocations on the surface and in the bulk. In the formation of dislocations and nanocrystallites an important role play the ion induced mechanical stress.

Possible mechanisms for dislocation formation and nanostructuring are discussed.

**MODIFICATION OF HARD ALLOYS BASED ON TUNGSTEN
CARBIDE BY PULSED ELECTRON BEAM MELTING OF Ti
COATING/WC-8%CO SUBSTRATE SYSTEM**

Yu.A. Denisova, Yu.F. Ivanov, P.V. Moskvina, A.D. Teresov, N.N. Koval

*Institute of High Current Electronics, 2/3 Akademicheskoy ave., Tomsk,
634055, Russia,*

Tel. +7(3822)491713, Fax +7(3822)492-410, e-mail:

yulija@opee.hcei.tsc.ru

The purpose of investigation is development of formation mechanisms of non-equilibrium structure-phase state in the surface alloy of metal ceramics based on tungsten carbide at intensive electron beam treatment of Ti coating/WC-8%CO substrate system and mechanisms of their influences on physical properties of the surface layer. Formation of the surface alloy was carried out by means of pulse melting of coating/substrate system by an intensive electron beam with the following parameters: electron energy of 10-20 keV, electron beam energy density up to 70 J/cm^2 , pulse duration of electron beam up to 200 μs , pulse repetition rate up to 10 Hz. Titanium coating was obtained by filtered arc deposition (FAD) with plasma assistance. The thickness of the coating was ~ 1 and 2 μm . The investigations of structure and phase composition of surface layer of coating/substrate system treated by pulsed electron beam were carried out by scanning electron microscopy, EDX analysis, X-ray diffraction analysis. Measurements of microhardness, wear and friction coefficient of surface layer were carried out. It is shown that electron-beam melting of Ti coating/WC-8%CO substrate system leads to formation in the surface layer of (Ti, W)C solid solution and W_2C phase. It is revealed that the structural and phase changes lead on the one hand to increase of surface layer microhardness, and on the other hand to some decrease of its wear resistance.

The work was supported by the Russian Foundation for Fundamental Research (Grant Nos. 11-08-98036-r_siberia_a and 11-08-00453-a)

**NANOSTRUCTURED LAYERS OF TRANSITIVE METALS
BORIDES ON FAST-CUTTING STEELS R18 AND R6M5,
GENERATED AT ELECTRON BEAM TREATMENT IN VACUUM**

A.D.Dorzhiev, N.N.Smirnyagina, A.S.Milonov, A.P.Semenov

*Institute of Physical Material Science SB RAS, Ulan-Ude, Russia,
ionbeam@pres.bscnet.ru*

Recently in surface engineering use technologies of processing of a surface the concentrated streams of energy, created by laser radiation, high-temperature plasma, electron and ion beams more and more.

One of ways of electron beam processing is electron beam treatment consisting in heating by an electron beam of a metal surface with put on it sating daub. Changing structure of the sating daub and an electron beam parameters, it is possible to receive various properties of a surface.

The report is devoted to research of an opportunity of application of electron beam heating for borides layers formation on surface of tool steels. We report on a new process to make layers by electron beam boriding.

As materials of researches were used carbon high speed steels (R18 and R6M5). Samples were prepared by daub drawing on a previously prepared surface of steel. The daub composition was consisted of 1:1 the boriding compounds (boron carbide B₄C or amorphous boron) and the organic binding. The solution 1:10 glue BF-6 in acetone has been used in quality the binding. After drawing daubs by thickness 1 mm samples dried before complete removal acetone. The treatment by electron beam has been carried out in an electro-vacuum installation containing a powerful industrial axial electron gun type EPA-60-04.2 and control blocks BUEL. The pressure in the working chamber did not exceed 2×10^{-3} Pa.

Microhardness of prepared layers was supervised on the PMT-3 hardness tester. The load on a diamond pyramid made up 50 g. The microstructure of samples was investigated using a metallographic microscopy "METAM RB-21".

At electron beam boriding of the steels R18 with capacity density of electron beam $J = 2.8 \times 10^4$ (W/cm²) the layer was formed as a result of deep profusion that has defined its structure. The directed crystallization at which the main axis linear dendrites are observed focused in a heat removal direction. The dendrite structure (the chain of separate globles) speaks a structure about vacillating character of their formation. At reduction of capacity density of

beam $=2.2 \times 10^4$ (W/cm²) the layer also contains the celebrity dendrites, however their quantity is not dominating.

The received results electron beam boriding were used for processing of replaceable plates, made from high speed steels (R18 and R6M5). All plates previously were subjected to standard heat treatment. Therefore with the purpose of softening steel prevention, the parameters of electron beam heating were got out so that temperature of heating of cutting plates did not exceed 550-600°C. After the electron beam processing of cutting plates, with put on them boron daubs the layer, thickness 8-10 microns, on a surface are formed. This layer has the specified thickness practically on whole length.

To estimate tribological properties of formed boride layer were carried out the strengths test of turning tool. Tests have been carried out on the skew-cutting lathe 1A616. For criterion of turning tool stability the time of achievement limiting wear on back plate equal 0,6 mm is accepted. The boride layer formation by thickness 8-10 microns on forward surface, are allowed to increase stability of the turning tool almost in 1,5-2 time.

The work is supported by the Russian Foundation for Basic Research (projects, 10-08-00918a and 12-08-98036-р_сибирь_а).

MICROSTRUCTURE AND PROPERTIES OF VACUUM ELECTRON BEAM FACING CuCr25 ALLOYS

V.G. Durakov¹, S.F. Gnyusov², B.V. Dampilon^{1,2}, S.Z. Dehonova¹

¹*Institute of Strength Physics and Materials Science,
2/4 Akademicheskii av., Tomsk, 634021, Russia*

²*National Research Tomsk Polytechnic University,
30 Lenina av., Tomsk, 634050, Russia*

electron@ispms.tsc.ru

The coatings from the cooper chromium composite produced by the electron beam facing in the vacuum on the cooper substrate have been investigated. The [effect](#) of processing of the electron beam facing and Ni alloying on the structure and the properties of the facing coatings has been [determined](#). The chromium based solid solution containing 2,5 - 4,5 % at. Cu and the copper based solid solution containing 3 - 5 % at. Cr form in process of the electron beam facing by means of the rapid crystallization of the melt-

ing zone. The melting of the chromium particles immediately in the coverage of the electron beam and their refining at the expense of the hydrodynamic and convecting flows in the melting metal bath occur with the density power of electron beam more $1 \times 10^5 \text{ Wt/sm}^2$. As a result of the electron beam facing, two of the dimension-type is appears in the surfaced coat (the bimodal distribution): the dendritic chromium is formed during solidification (the primary chromium particle), and the chromium precipitating at the boundaries and the within of the grain (the secondary chromium particle) as a result of age hardening of the solid solution of the copper based material. For CuCr25 contact material alloying by Ni the Cr phase was refined and presented nodular morphology. So the uniform microstructure of facing CuCr25 contact material is achieved.

INCREASE OF THE CORROSION RESISTANCE OF LOW-ALLOY STEELS BY PULSED PLASMA FLOWS TREATMENT

**P.S. Dzhumaev, V.L. Yakushin, B.A. Kalin, Aung Thurein Hein,
V.I. Polsky, M.S. Yurlova**

*National Research Nuclear University «MEPhI»,
115409, Kashirskoe shosse, 31, Moscow, Russia,
PSDzhumaev@mephi.ru*

Results of the investigation of influence of the high temperature pulsed plasma flows (HTPPF) treatment regimes on the corrosion resistance of low-alloy steel 20KhGNM in initial state and plated by rapidly quenched nickel based alloy STEMET 1305 are presented.

It is shown that the preliminary high temperature pulsed helium or nitrogen plasma flows treatment of steel samples leads to their corrosion resistance increase up to 30 times in conditions of AMU intergranular corrosion test (GOST 6032-2003). It is found, that level of the corrosion resistance increase depends on HTPPF treatment regimes. At that, the better corrosion resistance show samples that were treated by nitrogen pulsed plasma flows.

Increase of corrosion resistance of HTPPF-modified samples is caused by changing of the microstructure and structural-phase state of near surface layers. In such a case, as a result of sub-microcrystalline structure formation, the change of the corrosion mechanism from intergranular to frontal is observed.

A technique for plating samples of low-carbon and low-alloy steels by rapidly quenched nickel based alloy STEMET 1305 (Ni-18Cr-10Si). It allows obtaining a sufficiently homogeneous in the elemental composition and structural-phase state of the clad layer with the thickness of 35-40 microns and good adhesion to the steel substrate.

It is established that the processing of plated samples by pulsed plasma flows leads to a smoothing of the topography and the formation of sub-microcrystalline cell structure with a characteristic transverse dimension of the cells of 150-200 nm, and with increasing power density of the plasma flow surface relief decreases and increases the degree of alignment of the elemental composition of the clad samples surface.

It is shown that the plating of samples of low-alloy steel with nickel alloy STEMET 1305 and their subsequent processing of pulsed gas plasma flows can reduce the corrosion rate of up to 30 times, while the cladding with no further processing of the plasma flow does not increase the corrosion resistance of the samples due to the delamination of the clad layer during the corrosion tests. Optimal modes of cladding and plasma treatment to improve corrosion resistance are obtained.

ZEOLITE-CONTAINING CATALYST TREATED WITH UV AND LOW- TEMPERATURE PLASMA

**M.V. Erofeev¹, V.F. Tarasenko¹, I.S. Khomjakov², A.S. Medvedev²,
V.I. Erofeev²**

¹ *Institute of High Current Electronics, Russian Academy of Sciences,
Tomsk, Russia mve@loi.hcei.tsc.ru*

² *Tomsk Polytechnic University, Tomsk, Russia*

The experimental results of the influence of UV-radiation and its wavelength, low-temperature plasma and electron beam processing on the acid ZCC properties, as well as, catalyst activity during virgin benzene conversion into high-octane gasoline components have been presented.

It has been established that the preliminary narrowband UV emission of radiation on ZCC increases not only Brenstein, but also Lewis acid centers. Maximum concentration increase of these Lewis centers (up to 1.3 times) is achieved under the influence of the UV-radiation, including the wavelength of 308 nm and dose of 25 J/cm² on ZCC, resulting in the arene content in-

crease of up to 10-12% from virgin benzene condensate in comparison to unexposed N-HSZ.

The application of modified ZCC low-temperature plasma results in the increase of the arene yield up to 15% in high octane gasoline under conditions of virgin benzene conversion.

This work was supported by Federal Target Program (FTP), Ministry of Education and Science, Russian Federation (project № 2011-1.9-519-024-068).

FEARURES OF FORMING OF MYLTYLAERD NANOSTRUCTURING COATINGS ON THE BASIS OF Ni-Al

**M. V. Fedorishcheva, V. P. Sergeev, M. P. Kalashnikov,
A.V. Voronov**

*Institute of Strength Physics and Materials Science of S B of RAS,
Tomsk, 634021, Russia, Academicheskii, 2/4, fmw@ispms.tsc.ru*

Heat resisting of metal materials using in the modern equipment and technologies under the maximal temperature conditions are based on nickel alloys. The most intensive development of heat resisting aluminium coating has begun with creation of gas-turbine jet aircraft. At the first stages of development of gas-turbine engines it was possible to provide a necessary combination of thermal stability and heat resistance by creation of new alloys. The next year's application of protective coating on turbine became necessity.

The intermetallic compounds Ni_3Al and NiAl have a number of unique properties and they are objects of numerous investigations. Interest to intermetallide compound of nickel with aluminium and, in particular, to intermetallide Ni_3Al as to a constructional material is determined by anomalous temperature dependence of their mechanical properties.

In the present work were formed tree types of nanocrystalline layered coatings on the basis of Ni-Al system by magnetron deposition method. Three types of coating with Ni and Al layers in coatings were investigated. Thickness of layers in every type of coatings was 10-20 nm, 60-70 nm and 100-200 nm. Total thickness of all coatings was about 10 μm .

By X-ray method it is established, that there are two phases of binary state diagram of Ni-Al in structure of coatings: it is NiAl phase having

B2 type and some quantity of phases of Ti-Al system. In multilayered coatings of second and third types nickel and aluminium are the main phases and there is some quantity of phase of N-Al system. The phases of Ti-Al system are located on interlayer of nickel and aluminium. By scanning electronic microscopy (SEM) and transmission electron microscopy (TEM) of high resolution the morphology and elements composition of the surface of the intermetallic coating were investigated. Cross-section of all formed coatings was studied in details. It was established that structurally-phase state, chemical compound and tribological properties of coatings is depend on parametres of magnetron deposition.

**TO THE MODIFICATION OF THE MATERIAL SURFACE UNDER
THE PULSE IMPACT OF THE PLASMA FLOWS**

**A. T. Gabdullina, A. M. Zhukeshov¹, A. U. Amrenova²,
M. Mukhamedryskyzy³**

*Physical and Technical Department of Al-Faraby Kazakh National
University, Almaty, Kazakhstan, a_gabdullina@mail.ru,*

¹*Physical and Technical Department of Al-Faraby Kazakh National
University, Almaty, Kazakhstan, anuar_zhukeshov@mail.ru,
zhukeshov@physics.kz*

²*Physical and Technical Department of Al-Faraby Kazakh National
University, Almaty, Kazakhstan, amrenova_assem@mail.ru*

³*Physical and Technical Department of Al-Faraby Kazakh National
University, Almaty, Kazakhstan, inju_marzhan@mail.ru*

In modern technologies of the treatment of the structural materials with the aim of modification of the structure and properties are widely used the methods of plasma treatment, including magnetron and arc. Last time there are the active developments of the technologically more effective method, connected to the pulse impact on the material surface. High power density of the flow in pulse regime leads to create the materials with unique properties of the surface layer [1].

In present work are given the results of the investigations, connected with the application of the pulse flows of plasma for modification of the surface of the structure materials as industry steel (St.3) and 12X18H10T. At the chosen method of the influence on the St.3 early we discovered the change of

the structure and physical-mechanical properties of the thin surface layer till ~40-80 μm , on the surface of the 12X18H10T steel the thickness of layer is 2-4 times less [2, 3]. In this case the results, obtained by the method of scanning electron microscopy, shows that the thickness of the visually observed modified layer on St.3 is about ~5-10 μm . Further investigations made the basis to assume that at the certain parameters of the plasma treatment it is possible to get the strengthening of the surface layer on the bigger depth, then it is possible to observe visually. Herewith the strengthening of the given layer of the material is in 3 and more times in dependence on the treatment parameters and connected to the structural changes. The similar results were obtained at the using of the air medium as a plasma-forming gas and the following conditions: $P=5,3 \div 66,5$ Pa; $Q_1=(0,4 \div 4,8) \times 10^5$ J/m²; $n=1 \div 30$. In this case the generator of the pulse flows of plasma is the accelerator KPU-30 of the Al-Faraby KazNU with coaxial geometry of electrodes and the density of the power flow from 0.5 till 5 MW/m².

Investigation in this direction are continue. Also the results of the Mossbauer microscopy are obtained. The comparative analysis of the results was carried out with the application of the method of the scanning electron microscope on the microscope QUANTA 3D 200 a. The new data on the investigation of the relief of the surface by the method of atomic-force microscopy INTEGRA N-TERMA and the measurements of the microhardness on the hardness gauge METAVAL were obtained.

References:

- [1] F.B.Baimbetov, A.M.Zhukeshov, A.T.Gabdullina, Bulletin of National science academy of Kazakhstan, Physics and mathematics, **6**, 39 (2006).
- [2] A.M.Zhukeshov, A.T.Gabdullina, Surface, X-ray, neutron and synchrotron investigations, **11**, 95 (2009).
- [3] A.T. Gabdullina, V.P. Poltavtseva, Herald of Higher education establishment, **12**, 115 (2010).

**FORMATION OF PARAMAGNETIC CENTERS IN γ -IRRADIATED
BARIUM NITRATE AT 300 AND 77K.**

O. Gavrilyuck, V. Kh. Pak, M. B. Miklin, V. A. Nevostruev

Kemerovo State University, Kemerovo, Russia
pak@kemsu.ru

In this paper we investigated the radiation-stimulated processes in crystalline barium nitrate. Particular attention is paid to education, the kinetics of accumulation and destruction produced by the radiation paramagnetic centers in barium nitrate at room temperature and liquid nitrogen temperature.

**MODELS OF NON-ISOTHERMAL DIFFUSION UNDER SURFACE
TREATMENT USING PARTICLE BEAMS**

M. V. Gizbrekht, A. G. Knyazeva¹, M.A. Micolaichuk²

TPU, Tomsk, Russia, mv2016@mail.ru

¹ *TPU, Tomsk, Russia, anna-knyazeva@mail.ru*

² *TPU, Tomsk, Russia, mishas@ispms.tsc.ru*

The non-isothermal model based on [irreversible](#) processes [thermodynamics](#) is suggested for mixing under condition of surface treatment using particle beams. We have the thermal conduction and diffusion conduction equations for binary system taking into account cross effects including thermal diffusion and diffusion conduction. The mechanic stress which appear owing to heterogeneity field of concentration and temperature effect on mixing process either. In three component system, we have one more diffusion equation and cross diffusion items. For constant transfer coefficient, the particular problems could be solved analytically when the boundary conditions have been formulated. To solve the particular problems we apply fundamental methods. In particular case, the Laplace transform method is applicable. The reverse Laplace transform into original is carried out numerically. As an example, the particular problem of implanted impurity transfer in the plate was solved for elastic and viscoelastic Maxwell medium. Based on the analysis of the obtained solutions one can establish the conditions under which the thermal diffusion and mass transfer under the action of stresses play an im-

portant role. Similarly, the solutions of diffusion problems with different relaxation times of the diffusion fluxes were obtained [1].

Sources

1. Knyazeva A.G., Mikolaiuk M.A. *On diffusion problem in three component system with two relaxation times.* – *Russian Physics Journal № 11, 2011*

SHOCK-WAVE SPALL FRACTURE OF AUSTENITIC STEELS UNDER THE ACTION OF A NANOSECOND RELATIVISTIC HIGH-CURRENT ELECTRON BEAM

**S.F. Gnusov, V.P. Rotshtein¹, S.A. Kitsanov¹, A.E. Mayer²,
K.V. Khishchenko³, P.R. Levashov³.**

Tomsk Polytechnic University, Russia, E-mail: gnusov@rambler.ru

¹*Institute of High Current Electronics of SB RAS, Tomsk, Russia*

²*Chelyabinsk State University, Russia*

³*Institute of Thermophysics of Extreme States of the Joint Institute for High Temperatures, RAS, Moscow, Russia*

A comparative study of regularities of shock-wave hardening and rear-spall fracture of plane targets with thickness ≤ 10 mm made of polycrystalline austenitic steels AISI 304 and 110G13 (Hadfield steel) are performed. The accelerator "SINUS-7" was used as the shock-wave generator at following e-beam parameters: maximum electron energy 1.35 MeV, pulse duration at half-maximum 45 ns, maximum energy density on a target $3.4 \cdot 10^{10}$ W/cm². According to the numerical simulation in case of SS304, the peak pressure and duration of shock wave are ~ 20 GPa and ~ 0.2 μ s, respectively, and strain rate is $\sim 2 \cdot 10^6$ s⁻¹. It was found that, regardless of steel grade and thickness of the target, the microhardness depth profiles have a subsurface maximum, located at a depth of ~ 0.5 mm from the ablation hole bottom, which is in agreement with the calculated thickness of the heat affected zone of the e-beam. In the absence of spallation, the second microhardness maximum located at a rear surface is observed due to a reflection of a shock wave, herein, this effect is more drastic for steel 110G13. It was shown that for steels 304 and 110G13, the ductile transgranular and mixed ductile-brittle intergranular spall fracture modes are realized, correspondently. For both steels the thickness of the spall layer increases almost linearly up to ~ 0.7 mm with increas-

ing the target thickness, which agrees with the simulation results. From a comparison of simulation results and experimental data it follows the spall strength of both steels is ~8 GPa, despite the differences in the fracture modes. The effect of various factors on the mechanisms of hardening and spall fracture are discussed.

THE INFLUENCE OF THE SURFACE MODIFICATION AND BULK STRUCTURE MODIFICATION OF PURE TITANIUM VT1-0 AND TITANIUM ALLOY VT6 ON THEIR WEAR RESISTANCE.

**B.P. Gritsenko¹, U.F. Ivanov^{2,3}, N.N. Koval^{2,3}, K.V. Krukovskiy¹,
N.V. Girsova¹, A.D. Teresov², I.V Lopatin²**

¹*Institute of Strength Physics and Materials Science SB RAS, Tomsk, Russia,
e-mail: gritsenko@ispms.tsc.ru*

²*Institute of High Current Electronics SB RAS, Tomsk, Russia,
e-mail: yufi55@mail.ru*

³*National Research Tomsk Polytechnic University, Tomsk, Russia,
e-mail: gritsenko@ispms.tsc.ru*

Results of research of wear resistance the pure titanium VT1-0 and titanium alloy VT6 in two conditions (coarsegrained and ultrafinegrained (submicro- and nanodimensional range)) are presented. The ultrafinegrained structure was created by methods of intensive plastic deformation (all-round abc-pressing) and by high-intensity electron-beam treatment. Ion-plasma treatment of an alloy VT6 was carried out by saturation in plasma of the gas discharge of low pressure. As a result of the executed researches optimum modes of processing, resulting in increase of wear resistance in a few times are established – energy density, duration of impulse, frequency of following impulses (at electron-beam treatment); temperature, duration, pressure in the technological chamber etc. (at saturation in plasma of the gas discharge).

The morphology of friction surface were investigated. It is shown that at stages with steady-state low-rate wear on friction surface of specimen of pure titanium VT1-0 are organized secondary structure in islands-shaped, and at stages with high-rate wear the friction surface has the striated structure with traces grip. The elemental microanalysis of secondary structures has shown that besides the titanium in their compositions carbon, oxygen and iron are found out, at the same time on basic friction surface these elements are not

found. Thereby, in triboprocess take place the self-organization of stable secondary structures which provide multiple increase of wear resistance of technically pure titanium VT1-0.

STRUCTURE AND PROPERTIES OF IRON-COPPER SYSTEM, FORMED BY ELECTRON-ION-PLASMA METHODS

**Yu. F. Ivanov, S. Yu. Filimonov, A. D. Teresov, E. A. Budovskikh¹,
V. E. Gromov¹**

*Institute of High Current Electronics SB RAS, Tomsk, Russia,
yufi55@mail.ru*

¹*Siberian State University of Industry, Novokuznetsk, Russia,
gromov@physics.sibsiu.ru*

Materials based on of iron-copper combination (steel- copper) to the present time are widely used in various industries, despite the difficulties of formation, caused by limited mutual solubility of these elements at equilibrium conditions. The most successful are technologies, based on different methods of sintering of iron and copper powders (the so-called pseudoalloys).

Work is aimed to identify regularities and research of mechanisms of formation of nanoscale structural and phase states in the iron-copper system, which synthesis was initiated by the impact of the combined method, which combines electroexplosive doping and irradiation of high-intensity pulsed electron beams submillisecond duration. Formation of iron-copper alloy was made in two stages. At the first stage of the processing of samples of steel 45 was performed by the plasma formed at electrical explosion of copper foil with thickness of 20 μm . At the second stage surface treated with plasma was irradiated by high-intensity electron beam at different energy densities of the electron beam (10...30 J/cm^2), pulse duration (50...200 μs) and number of (1...200) pulses at constant electron energies (18 keV) and pulse frequency (0,3 s^{-1}).

Optimal mode of electron-beam processing, which allows to form in the surface layer with thickness of 10 μm structure of cell (dendritic) high-speed crystallization with a cell size of 300...500 nm is revealed (fig. 1, *a*). Crystallization cells are separated by interlayers of the second phase (fig. 1, *c*). Layers thickness varies from 30 to 60 nm. At the junction of cell borders in-

terlayers are transformed into the formation of round shape, the sizes of which reach 150...200 nm. Indexing of micro-electron diffraction pattern (fig. 1, *b*), received from the cell structure, showed that the volume of the cells is formed by α -phase (solid solution based on BCC iron). Interlayers, dividing cells, are multiphase formations. Main phase is copper, there are also small amounts of oxides CuO , Cu_2O , Fe_2CuO_4 and CuFeO_2 .

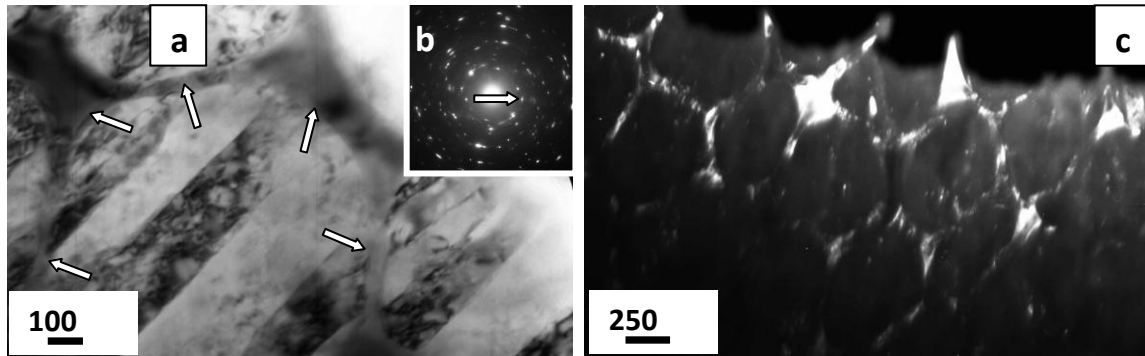

Fig. 1. SEM images of the surface layer of steel 45 subjected to electroexplosive copper doping and subsequent irradiation with an electron beam; a – bright field; b – micro-electron diffraction pattern; c – dark field, obtained if reflex $[002]\text{Cu}$. The arrows indicate: on (a) – layer of copper, located at the boundaries of cell crystallization at (b) – reflex in which the dark-field image is obtained.

The work was partially supported by Fundamental Research Program of the Presidium of RAS № 24.

NANOSTRUCTURAL POWDERS BASED ON ZIRCONIUM OXIDE: REGULARITIES AND MECHANISMS OF FORMATION OF PHASE COMPOSITION

**Yu. F. Ivanov, E. A. Petrikova, Yu. A. Kolubaeva, A. D. Teresov,
S. Yu. Filimonov**

*Institute of High Current Electronics SB RAS, Tomsk, Russia,
yufi55@mail.ru*

Nanostructuring of ceramic materials and coatings is one of the methods of significant increasing their service characteristics. The physical meaning of such an approach is to reduce the level of large-scale localization of deformation in a nanostructured material, which leads to a more uniform distribution of elastic stresses in a significant volume of material under external mechanical or temperature effects on the surface. As a result, significantly increases the energy of the nucleation of stress concentrators, decreasing probability of formation of micro- and macrocracks. Nanostructuring of polymorphic materials is accompanied, as a rule, the effect of stabilizing of high-temperature modifications, and thus, formation of multiphase states.

The aim of this work was studying of the role of size factor in the formation of phase composition of ceramic material based on zirconium dioxide. The material used in the study were polycrystalline powders based on zirconium dioxide, synthesized by methods of plasma chemistry, which are characterized as shown previously performed studies, by wide variation (from ones to hundreds of nanometers), size of the crystallites.

It was established by method of analyzing of zirconium dioxide powders electron diffraction patterns that in the crystallites of small size ($d \leq 15$ nm) polymorphs modification with cubic crystal lattice is dominated. The presence of a minor tetragonal distortion of reflexes may be due to the elastic stresses, and with the variation of the lattice parameter. When $d = 20-25$ nm polymorphs modification with tetragonal crystal lattice is dominated. Further growth of average size of the crystallites is accompanied by a decrease of tetragonal distortion of reflexes, which is obviously due to the substitution of tetragonal modification of zirconium dioxide by monoclinic modification. The modification of zirconium dioxide with yttrium and / or calcium leads firstly to stabilizing of high-temperature modification, shifting the range of its existence to larger grain size, and secondly, to increase of elastic distortions of zirconium dioxide crystal lattice.

The analysis of factors contributing to stabilizing of zirconium dioxide powder high-temperature modification was done. It is shown that in addition with size effects (nanostructurization of material) and chemical effects (injection of stabilizers) elastic contact stresses play an important role, which are formed along intraphase and interphase boundaries of the crystallites and border areas of polycrystalline aggregate which is distorting the crystal lattice. This is indicated by a set of results obtained in analysis of electron diffraction patterns. Namely, the distortion of diffraction spots detected on electron diffraction patterns of zirconium dioxide films, the magnitude of which essentially depends on size of material crystallites. Discontinuity of a polycrystalline aggregate by introduction of micropores and microcracks, minimizing contact on boundaries of the crystallites leads to relaxation of elastic stresses, reduces the distortion of crystal lattice, which reduces the distortion of diffraction spots on electron diffraction patterns.

This work was supported in part by grant RFBR (project 11-08-98020-p_cyбupb_a).

MODIFICATION OF STRUCTURE AND PROPERTIES OF TITANIUM SURFACE LAYER BY ELECTROEXPLOSIVE ALLOYING AND ELECTRON-BEAM TREATMENT

**Yu. F. Ivanov, A. D. Teresov, N. A. Soskova¹, S. V. Raykov¹,
E. A. Budovskikh¹, V. E. Gromov¹**

*Institute of High Current Electronics SB RAS, Tomsk, Russia,
yufi55@mail.ru*

¹*Siberian State Industrial University, Novokuznetsk, Russia,
gromov@physics.sibsiu.ru*

Titanium and its alloys, that are considered nowadays to be perspective constructional materials, have significant disadvantages: low durability, high tendency to sticking, high coefficient of friction in combinations with almost all materials. The goal of the present investigations is to develop the method of multiple increase of strength and tribological properties of technically pure titanium subjected to surface irradiation of concentrated energy fluxes. Modification of titanium surface layers was carried out in two stages. At the first stage the treatment was carried out by plasma formed by electric explosion of carbon graphite fibers with TiB₂ powder aliquot placed on them. The mass of

carbon graphite fibers was 70 mg, mass of powder aliquot – 50 mg. At the second stage the surface treated by plasma was irradiated by high intensive electron beam varying the energy density of electrons beam (40...60 J/cm²) and the pulse duration (100...200 μs) at the unchanged values of electrons energy (18 keV), quantity (10...20) and pulse repetition rate (0,3 s⁻¹).

By the methods of scanning electron microscopy of transverse metallographic sections it was found that electroexplosive alloying leads to formation of multilayer structure with ~ 60 μm thickness. The surface layer is characterized by a high level of roughness, contains a large number of particles of destroyed carbon graphite fibers and TiB₂ powder. Surface microhardness of alloying is 2500 HV and exceeds the base microhardness by more than 12 times.

The subsequent high-intensive electron beam treatment does not eliminate multilayer structure of the modified material. The treatment at the optimal mode decreases the level of surface roughness up to ~ 90 μm and microhardness of the near-surface layer up to 2000 HV. Wear resistance of the modified layer increases base wear resistance in ~7,3 times, coefficient of friction decreases in ~1,2 times.

By the methods of X-ray diffraction analysis it was shown that in the surface layer multi-phase structure forms after electron-beam treatment. Its main phases are α-Ti, TiC, TiB₂ and Ti₃B₄.

By the methods of diffraction electron microscopy the investigations of the phase composition and defect layer structure were carried out. It was stated that in the layer adjoining the surface nano-sized dendrite structure (60...100 nm) forms on the basis of α-Ti. In the layer, located at the depth of ~ 50 μm, nano-sized structure (80...100 nm) of globular types forms.

The carried out complex investigations and phase composition of the modified layers allowed to express judgments in regard to mechanisms of multiple increase of strength properties of technically pure titanium subjected to irradiation of concentrated energy fluxes.

This work was supported in part by grant RFBR (project 11-02-12091)

**THE SYNTHESIS OF GALLIUM ARSENIDE FILMS ON
THE SILICON SUBSTRATE BY IONICS ABLATION**

A. V. Kabyshev, F. V. Konusov, G. E. Remnev

*Institute of Physics of High Technology, Tomsk, Russia,
konusov@hvd.tpu.ru*

Integration of perspective semiconductors GaAs and Si is important in optoelectronic aims but restrains by problems of defectiveness and materials compatibility. These problems are overcome by application of cyclic annealing, two-level growth of layers and creating of thin transition layers. Pulsed deposition methods including those from RF-plasma, flash evaporation, co-evaporation, laser ablation were applied successfully. Films deposited from plasma, created by power impulse beam (PIB), allow to realize high velocity films deposition on considerable squares in different substrates but its photoelectrical properties were not studied in sufficient degree.

The purpose of this work is investigation of photoelectrical properties of thin (100–300 nm) GaAs films deposited on polycrystalline silicon by pulsed ions ablation (PIA) by using PIBs by accelerator «TEMP» ($U=200$ kV; $j=180-230$ A/cm², $t_p\sim 60$ ns, $n_{imp}\sim 100$, $P=10^{-2}$ Pa, $v_d\leq 1$ mm/s) and its change after thermal vacuum annealing ($T_{an}=300-900$ K, $P<10^{-2}$ Pa). Surface and volume dark conduction σ , photoconduction $\sigma_{ph}=\sigma_{h\nu}-\sigma$ ($\sigma_{h\nu}$ —conduction at illumination $h\nu=1.5-4.0$ eV), photosensitivity $K(U,T,h\nu)=\sigma_{ph}/\sigma$ were measured at $T=300-500$ K.

Optical absorption spectrum $\alpha(h\nu)$ of PIA-GaAs/Si films is similar to spectra of GaAs and Si but differ in its continuity, shifted to UV-region compare with Si ones that is stipulated by quasi dynamic disorder, created by ions beam in GaAs crystalline lattice. Spectra and interconnections $\sigma_{ph}(\sigma)$ and $K(E_g)$ (E_g —optical gap) are joint with same of traditionally produced Si and GaAs. That indicates on good optical quality of PIA films and correlation between optical and electrical properties. Values K after deposition are higher. Substrate effect strongly on films properties. Interface states, biographical defects and GaAs nanocrystals influence on characteristics at $h\nu>\tilde{\nu}$. Films appear linearity of $I-U$ characteristics and interconnection $K\sim U^s$ ($s=0.3-0.4$) stipulated by high density $N\geq 10^{18}$ cm⁻³ of defects localized states. Activation transport and n -type of σ_{ph} with energies 0.05–0.21 eV dominates. Hopping transport with defects states contributes also. States density is decrease with its depth. Characteristics σ , σ_{ph} , $K(h\nu)$, $\sigma_{h\nu}$ and barrier height ($q\cdot\phi_B=0.2-0.3$ eV) were changed at annealing in two stages

$T_{an}=300-600, 600-900$ K. In summary, photoelectrical properties of PIA GaAs/Si thin films allow to recommend such production methods for application in solar cell technology or other aims.

ELECTRICAL SURFACE CONDUCTIVITY IN DIELECTRIC MATERIALS INDUCED BY ION-THERMAL MODIFICATION

A.V. Kabyshev, K.V. Lebed

*National Research Tomsk Polytechnic University, Tomsk, Russia,
e-mail: lkv@sibmail.com*

At present, modification of materials by means of ion implantation is important in high technology. After irradiation of the insulating materials with ions, chemical, mechanical and electrical properties of their surface strongly change as compared to original materials. A great attention to the effect of electrical properties changes of the insulating materials after an ion irradiation is given.

As the ion fluence increases to a certain value, the concentration of implanted ions rises, but the dispersion of materials and implanted ions rises too. The equilibrium between ion implantation and dispersion is installed, when the dose to reach this value. This leads to the transformation of the implanted ions distribution profile and saturation of their concentration. The larger concentrations can be obtained using method of the ion mixing that allows removing the implanted ions concentration restriction. This mode of ion implantation is proposed to sputter the thin film on an insulator surface before ion implantation or matching of ion implantation and sputtering. The mode allows getting the conductive layer with necessary concentration depth profile by fluence is smaller as compared with ordinary ion implantation.

The fabrication of near-surface conductive layer on the insulators is result of ion implantation and post-implantation annealing. Control of the resistance this layer can be accomplished in the range from 10^3 to 10^{15} Ohm by the ion implantation and post-implantation annealing parameters change.

**FEATURES FORMING OF MULTILAYERED
NANOSTRUCTURING COATINGS ON THE BASIS OF Ni-Al SYS-
TEM, GENERATED BY MAGNETRON DEPOSITION METHOD**

M.P. Kalashnikov, V. P. Sergeev, M. V. Fedorishcheva, V. V. Neyfeld,

*Institute of Strength Physics and Materials Science of S B of RAS, Tomsk,
634021, Russia, Academicheskii, 2/4, retc@ispms.tsc.ru*

Essential expansion of application of strengthening protective and functional coatings is expected from implementation in the industry of technologies of synthesis of a new class of coatings - multilayered composite. The purpose of this paper is research of a structurally-phase state and tribological properties of multilayered composite coatings on the basis of Si-Al-N / Zr-Y-O systems, deposited by pulse magnetron sputtering method on substrates from a high-strength steel 0,3C-Cr-Mg-Si-2Ni.

Electron-microscopic research of structure of the multilayered coatings consisting from alternating equal thickness Si-Al-N and Zr-Y-O layers, with thickness of each layer from 0,15 μm to 5 μm is carried out. It is shown that boundaries between layers sharp enough and the chemical composition in each layer are homogeneous. There is nanocrystalline phase zirconium oxide ZrO_2 in layers on the basis of Zr-Y-O and in layers on the basis of Si-Al-N has in your compound partially amorphous, partially nanocrystalline nitride of silicon Si_3N_4 .

By X-ray analysis of multilayered composite coatings on the basis of Si-Al-N/Zr-Y-O systems depending on producing conditions it is established:

1. At thickness of layers from 5 to 0,15 μm in a multilayered coatings if the chosen modes of sputtering providing equal thickness of layers are observed, the relation of volume fractions of phases is constants independent of quantity of layers in a coatings.
2. Assisting of coatings deposition by ionic bombardment leads to decreases of the relative of nitride component in coatings.

Research of wear resistance and adhesion of coatings depending on condition of producing is carried out. It is established that multilayered composite coatings on the basis of alternating layers Si-Al-N / Zr-Y-O have 1 μm in thickness at the total thickness of a coatings 12 μm , deposited by ionic-magnetron method, have high wear resistance. Addition of coatings deposition by assisting ionic bombardment leads to decrease on ~40 % of wear resistance of coatings. It is connected with change of phase compound in coatings. Dependence of adhesion and wear resistance on a layers thickness is es-

tablished. At a constant thickness of coatings as a whole and in case when all dissimilar layers are equal this dependences have extreme character with a maximum in area of 1 μm . The possible reasons of such dependence are discussed.

COPPER GERMANIUM ALLOYS FORMATION BY THE LOW TEMPERATURE ATOMIC HYDROGEN TREATMENT

A.I. Kazimirov, E.V. Erofeev¹, V.A. Kagadei²

*Tomsk State University of Control Systems and Radioelectronics,
40 Lenina Prospect, Tomsk, Russia 634050,
smart300389@mail.ru*

¹ *Research & Production Company "Micran", 47 Vershinina st., Tomsk,
Russia 634045, erofeev@sibmail.com*

² *Institute of High Current Electronics SB RAS, 2/3 Akademichesky Ave.,
Tomsk, Russia 634055, vak@micran.ru*

The thin films of stoichiometric copper germanide compounds (Cu_3Ge) are perspective material for metallization in micro- and nanoelectronics devices. It is known, that Cu_3Ge compounds are achieved room-temperature resistivity comparable to that of elemental Cu, with superior thermal and chemical stability upon exposure to air or oxygen at room temperatures. However there are no studies where Cu_3Ge alloys were used as transistor's metallization material. Because, traditionally Cu_3Ge alloys are formed using heat treatment ($T = 400^\circ\text{C}$) for a long time ($t = 20\text{--}30$ min) in a high vacuum environment. It is difficult to introduce into resist lift-off technique at manufacturing GaAs RF semiconductor devices and monolithic integrated circuits. It is known, that the low-temperature atomic hydrogen treatment can stimulate diffusion of Au, Ni, Cu and In into Ge crystalline substrate. The activation of the solid state diffusion can be caused by the surface recombination of hydrogen atoms into molecules. It is possible to assume that the atomic hydrogen treatment of Cu/Ge thin-film system can solve the above-named problem and create CuGe compound at the lowered temperatures

The purpose of the present work is investigation the opportunity of the formation of CuGe compounds by atomic hydrogen treatment at room temperature.

In experiments for the CuGe compound formation with low temperature atomic hydrogen treatment *i*-GaAs (100) substrate was used. To remove the oxides of GaAs surface before deposition, the substrate was treated in HCl : H₂O (1 : 10) solution, followed by rinsing in de-ionised water and drying in a flow of pure nitrogen. The Ge ($d = 78$ nm) and Cu ($d = 122$ nm) thin films were deposited by the vacuum e-beam evaporation. The samples were treated in a flow of atomic hydrogen with a flow density of $j = 10^{15}$ at·cm²·s⁻¹ during $t = 5$ –30 min at room temperature or were annealed in vacuum environment at a temperature $T = 400^\circ\text{C}$ during $t = 30$ min for CuGe compound formation. The surface morphology of treated samples was investigated with scanning electron microscopy (SEM), the distribution of Cu and Ge elements in the depth of the samples was investigated by Auger electron spectroscopy (AES) and the electrical resistivity of CuGe thin films was measured by the four probe method.

There was found, that the treatment of Cu/Ge/GaAs samples in the atomic hydrogen flow with density $j = 10^{15}$ at·cm²·s⁻¹ during $t = 5$ min at room temperature leads to interdiffusion Cu and Ge thin films with the formation of the polycrystalline CuGe compound with vertically oriented grains ($d = 100$ –150 nm) and low electrical resistance (4,5 μOhm·cm). Increasing the treatment time in atomic hydrogen flow lets to improve interdiffusion of Cu and Ge elements. The mechanisms responsible for discovered phenomenon has been discussed.

CHANGES IN THE STRUCTURE AND MECHANICAL PROPERTIES OF COMMERCIALY PURE TITANIUM UNDER THE INFLUENCE OF ELECTRON-BEAM PROCESSING

**Kretova O.M., Panin AV¹, Kazachenok M.S.², Perevalova O.B.³,
Teresov A.D.⁴**

¹*Institute of Strength Physics and Materials Science SB RAS, Tomsk,
oksikom@bk.ru*

²*Institute of Strength Physics and Materials Science SB RAS, Tomsk,
pav@ispms.ru*

³*Institute of Strength Physics and Materials Science SB RAS,
Tomsk,perevalova52@mail.ru*

⁴*Institute of High Current Electronics SB RAS, Tomsk*

In recent years, along with the traditional technologies of surface hardening (quenching, mechanical, chemical and thermal effects, etc.) treatments of structural materials by charged particle beams of high energy densities are increasingly used. This technology allows to form a multilayer structure highly nonequilibrium, which contributes to a significant increase in wear resistance, corrosion resistance, the dynamic strength of the products, reduce the friction coefficient, etc. In this paper we investigated the influence of the energy density of the electron beam on the topography, structure and mechanical properties of commercially pure titanium.

Atomic force microscopy revealed that treatment with an electron beam leads to a substantial change in the surface topography of the titanium samples. After irradiation with the energy density 12 J/cm^2 grinding marks disappear and we observe surface grain boundaries with small folds oriented in different directions. Moreover, titanium drops are observed on the surface, which indicate melting of the surface layer during irradiation. By increasing the density of the beam energy up to 24 J/cm^2 height and lateral dimensions of the folds increases, and there are smooth areas on which there is no folding.

Surface treatment of samples of commercially pure titanium low-energy electron beams leads to saturation of the surface layer of oxygen and the formation of nanocrystalline oxide layer. Under the oxide film is observed lamellar structure, which arose as a result of deformation twinning and martensitic transformation, and subgrain structure of α -Ti oxides with nanocrystalline particles of titanium along the boundaries of subgrains. X-ray analysis showed that under the influence of the electron beam changes the pa-

rameters of the hcp lattice of α -Ti in the direction of increasing the ratio c/a and decrease the half-width of lines in comparison with the annealed sample. In addition, there is a change in the relative intensity of diffraction peaks between the source and electron beam-treated samples.

The formation of a thin surface layer of titanium VT1-0 nano-(submicro-)crystalline structure leads to an increase in the hardness of the surface layer and causes an increase in the mechanical properties of the samples. The degree of surface hardening is determined by the energy density of the electron beam.

ION-PLASMA ETCHING AND CLEANING OF MATERIAL SURFACES IN PLASMA OF ARC LOW-PRESSURE DISCHARGE

**I. V. Lopatin, S. S. Kovalsky, P. M. Schanin,
N. N. Koval, O. V. Krygina**

*Institute of High Current Electronics SB RAS, Tomsk, Russia,
krygina_82@mail.ru*

In the work results of the complex systematized investigations of clearing, heating and etching processes of metal surfaces in plasma of arc low-pressure discharge are presented. At first, experiments on research of ion-plasma treatment and its influence on a state of a surface and property of surface layer have been carried out.

The material of substrates were stainless steel 12Cr18Ni10Ti, tool steel R6M5, titanium alloy VT-6, hard alloy WC-8%Co. The sample surface before and after ion-plasma treatment were investigated by optical three-dimensional profilometer, scanning electron microscope, an optical interferometer, micro- and nanohardness tester.

Secondly, investigation of gas-discharge plasma by a method of probe diagnostics with use of the automated system for fixation of probe characteristics has been carried out. On the basis of results of measurements the optimum ion-plasma conditions for clearing and/or etching of a materials surface with various content have been allocated.

OPTICAL CONTROL OF A METAL SURFACE MELTING UNDER ITS IRRADIATION BY PULSED INTENSE ELECTRON BEAM

V.I. Engelko, V.G. Kovalev, V.A. Kubasov

*Efremov Institute of Electrophysical Apparatus, St.Petersburg, Russia,
pavlov@mit.niiefa.spb.su*

In the course of modification of a metals irradiated by pulsed intense electron beams (PIEB) the important role is played by definition of the moment of the surface melting beginning. The optical technique was developed for definition of this moment. Researches of reflective ability of targets from a number of metals (aluminum, stainless steel, nickel, copper, the titan, molybdenum, tantalum, zirconium), irradiated by PIEB with the current density $\sim 10 \text{ A/cm}^2$, kinetic energy of electrons 120-240 kV, duration of a PIEB pulse 20-200 mks were carried out. Experimental results are in good correlation with data of numerical calculations for aluminum, stainless steel EP823 and nickel. The received results allow to optimize the process of material treatment without preliminary investigations of its interaction with PIEB.

PROPERTIES NANOCRYSTALLINE NITRIDE COATINGS, OBTAINED BY DIFFERENT REJIME

O.P. Kul'ment'eva¹, A.M. Mahmmood², A.A.Andreev³

¹*Biyovis Holding, POBox 227, 40030, Sumy, Ukraine
(*e-mail : opkulm@malt.ru)*

²*Sumy State University, R-Korsakova str., 2, 40007 Sumy, Ukraine*

³*NSC "Kharkov Physico-technical Institute" Kharkov, Ukraine*

Phase composition, hardness and coefficient of sliding friction of titanium nitride coatings, obtained at different technological conditions, is studied. The varied parameters it was been pressure of nitrogen in the vacuum chamber, substrate temperature, displacement potential, doposition in the continuous or impuls regime. The parameters of lattice, coefficient of sliding friction and hardness are definite.

For optimization of sputtering process and receipt of homogeneous on composition coatings, which has minimum deforming tensions, in this work

influence of technological sputtering parameters was conducted on the coatings structure from titan nitrogen was research. As substrate stainless steel of 12X18H10T was used. Coatings manufactured in the vacuum-arc set-up at pressure of nitrogen $10^{-3} - 3 \cdot 10^{-2}$ Pa, current of arc 85 A, tension of displacement on the sample was $U_H = 25, 70, 150, 200$ and 230 V, with pre-cleaning of surface by bombardment the titan ions at the attached constant potential of displacement 1 kV during 5 min. Distance from the working surface of cathode to the samples was 250 mm. The temperature of substrate was varied from 130 to 360°C. A fluidizer besieging of coverages was equipped a device, allowing to control the temperature of besieging with exactness of 5°C. The coating from TiN had a thickness of 5 μm .

The obtained coatings can be attributed to high-hard, as they rotined a microhardness from 21 to 36 GPa. Crystals size, definite from the coherent-scattering region, have a value from 10,29 nm to 14,37 nm. It was show that in the varied limits nitrogen pressure in a vacuum chamber influence on the parameters of coarse-fine. The parameter of crystalline lattice of TiN coatinge change from $a = 0,4248$ nm up to 0,4222 nm (in massive TiN $a_0 = 0,424$ nm), in other words in coatings formatted both, as well as, tensile and compressive residual stresses. The coefficient of sliding friction not monotone variate from 0,38 to 0,30 depending on pressure of nitrogen in a vacuum chamber.

INFLUENCE OF GENERAL ABSORBED DOSE ON THE CONTENT OF THE GEL-FRACTION IN THE ION-EXCHANGE POLYMER HYDROGELS

V. M. Le, V. D. Zhevnyak¹, V. H. Pak², V. A. Nevostruev³

Kemerovo State University, Kemerovo, Russia, ya808@ya.ru

¹ *Kemerovo State University, Kemerovo, Russia, valdav9@mail.ru*

² *Kemerovo State University, Kemerovo, Russia, v.h.pak@mail.ru*

³ *Kemerovo State University, Kemerovo, Russia, anchem@kemsu.ru*

The paper is devoted to analysis of the total absorbed dose of radiation on the content of the gel-fraction in the ion-exchange polymer hydrogels in order to achieve high degrees of conversion of monomers that provide biologically inertness of materials. Ion-exchange polymer hydrogels in the form

of a contact lens designed for use in ophthalmology for the treatment of chemical burns and infectious diseases of the eye.

The content of the gel-fraction in the ion-exchange polymer hydrogels synthesized under the influence of different absorbed doses (25, 30, 35, 40 kGr) of ionizing radiation had been analysed.

The effect of the total absorbed dose of the radiation to water content and strength characteristics of ion-exchange polymer hydrogels had been analysed.

The studies had determined the absorbed dose of γ -radiation in the radiation polymerization of ion-exchange hydrogel in which the maximum reached value of the content of gel fraction does not affect its exploitation properties. Comparison of all results allows to consider optimal the absorbed dose of γ -radiation 35 kGr with radiation synthesis of polymeric ion-exchange hydrogels.

THE MODIFICATION OF THE GRAPHITE SURFACE BY POWERFUL PULSED BEAMS OF C AND H IONS

**Golosova O.A.¹, Ligacheva E.A.³, Ligachev A.E.⁴, Polushin N.I.⁵,
Potemkin G.V.², Pushkarev A.I.², Remnev G.E.²**

¹ *Belgorod State University, Belgorod, Russia*

² *Tomsk Polytechnic University, Tomsk, Russia*

³ *Tsiolkovsky Moscow Aviation Technological Institute, Moscow, Russia*

⁴ *General Physics Institute of the Russian Academy of Sciences,
Moscow, Russia*

⁵ *National research Moscow Institute of Steel and Alloys,
Moscow, Russia*

Unlike the metals [1, 2], the processes carrying out on the surface of the graphite and in its near-surface layer during the action of powerful ion beams (PIB) have been hardly investigated. The report presents the experimental results obtained when studying the topography of the graphite surface and the structure of its near-surface layer after irradiation by powerful pulse beams of H^+ and C^+ ions on the TEMP-4M accelerator.

The pyrographite was chosen as an irradiated material. The parameters of the ion beam: 70% of one- and two-discharge $C + 30\%H^+$ ions, 250-300 keV ion energy, 50 A/cm² ion current density, ~ 80 ns half-height pulse

duration, the number of pulses is 5 and 100 under the pressure of the residual gases inside the chamber being $(3-4) \cdot 10^{-4}$ torr. The topography of the surface was studied by the Quanta 600 FEG scanning electron microscope, and the structure of the near-surface layer by means of the X-ray analysis.

The spherical particles on the surface of the pyrographite were revealed after the PIB action under the short-pulse implantation mode (100 pulses). The phase composition of the near-surface layer has not been altered.

References

1. Sulima A.M., Shulov V.A., Yagodin Yu. D. Surface coating and service properties of machine elements. M.: Mechanical engineering, 1988. 240 p.

2. O.A. Bytsenko, A.G. Paykin, V.A. Shulov, *et.al.*, Proceedings of the 8th International Conference of Interaction of radiation with Solids, IRS-2009, Minsk, Belarus, September 23-25, 2009, p. 305-307.

SURFACE MODIFICATION OF MAGNESIUM ALLOY UNDER THE ACTION OF NANOSECOND PULSED ELECTRON BEAMS

**Bobryshev B.L.¹, Bobryshev D.B.², Zemlyanoy G.Ya.²,
Kaikanov M.I.⁴, Ligachev A.E.³, Mukhametov A Ch.²,
Ponomarev D.V.⁴, Potemkin G.V.⁴, Remnev G.E.⁴**

¹*Tsiolkovsky Moscow Aviation Technological Institute, Moscow*

²*JSC «AVANGARD», Moscow*

³*A. M. Prokhorov General Physics Institute, Russian Academy of Sciences,
Moscow*

⁴*Tomsk Polytechnic University, Tomsk*

The report presents the results of magnesium alloy modification under the action of nanosecond pulsed electron flows. We used the accelerator TEA-450 (the electron energy is 400 keV, the pulse current density is 200 A/cm², the pulse duration is 60 ns, the pulse repetition rate is 0.2 Hz, the number of pulses is 3, 50, 500 pulses) and the “Astra” accelerator (the electron energy is 400 keV, the pulse current density is 20 A/cm², the pulse duration is 200 ns, the pulse repetition rate is 200 ns, the pulse repetition rate is 0.2 Hz, the number of pulses is 3, 50, 500 pulses). The presence of a significant portion of the low-energy electrons is typical for the “Astra” accelerator in this mode.

The changes appearing on the surface of the magnesium alloy under the action of the beams reveal their more significant dependence on the number of pulses rather than on the pulse current density. Also the most of alternations in the shape of the surface relief are observed for the low-energy electron beams. The data on the microhardness and the corrosion properties of the ML5 magnesium alloy are given for the above-indicated parameters of the electron beams.

LOW-TEMPERATURE (400 °C) NITRIDING OF 12KH18N10T STEEL IN ELECTRON BEAM PLASMA

A. I. Menshakov, N. V. Gavrilov

*Institute of Electrophysics, Ural Division of the Russian Academy of Sciences,
Ekaterinburg, 620016, Russia
Phone: (343)2678778, Fax: (343)2678794,
E-mail: gavrilov@iep.uran.ru*

The method of plasma generation by gas ionization with low-energy (0.1-1 keV) electron beam was used for nitriding of 12Kh18N10T steel in Ar-N₂ mixes at pressure of 0.1 - 10 Pa and low bias voltages and ion energies. Influence of ion current density (0.5 - 13 mA/cm²) on rate of the steel nitriding was investigated at the fixed low energy of ions (100 eV) and constant temperature of samples (400°C) provided by change of electron beam parameters. Existence of optimum value of the ion current density, caused by competing action of processes of nitrogen diffusion in volume and ion sputtering of a surface was shown. Depth distributions of microhardness and nitrogen concentration in surface layer were obtained by methods of dynamic nanoindentation and nuclear reactions. Hardened layers with the thickness of up to 8 micron which microhardness of up to 12 GPa were produced after nitriding during 4 h. Concentration of nitrogen on depths 1 - 2 microns is ~25 at. %, on the steel surface this one grows up to 50 at. %. XRD analysis has confirmed the formation of expanded austenite and iron nitride phases, while the contents of the iron nitrides increases with rise of the ion current density.

**RESEARCHING of HYDROGEN ACCUMULATION in the SAMPLES
of PALLADIUM, SILVER and SILVER-PALLADIUM ALLOY**

**N.N. Nikitenkov, I.T. Sigfusson¹, Yu.I. Tyurin, V.S. Sypchenko,
A.O. Saprykina, O.V. Vilkhivskaya**

*Tomsk Polytechnic University, Tomsk, Russia, nikitenkov@tpu.ru,
Lenin str., 30, 634050*

*¹University of Iceland, Innovation Centre, Keldnaholt, IS112,
Reykjavik, Iceland*

Currently, palladium is a very valuable element when used in an alloy with other metals. For example, palladium alloys with silver are used in communications equipment (making contacts), in jewelry, dentistry (dentures), and even in manufacturing of parts of pacemakers. The study of palladium-silver alloys is topical today for hydrogen energetics as hydrogen actively diffuses through the palladium for the deep hydrogen cleaning.

Hydrogen storage in metals considerably changes their properties. This happens in different ways depending on the medium in which saturation takes place. In this report the results of hydrogen accumulation in palladium (Pd), silver (Ag) and Pd-40Ag alloy at the electrolytic, plasma and gas (at high pressure and temperature) saturation is studied. Saturated and initial samples were investigated by thermo-stimulated gas release (TSGR) method during linear heating of the samples (1°C/s), using the setup described in [1], by recording and analyzing the temperature spectra TSGR.

Particularly, the following conclusions were drawn. TSGR temperature of H₂ spectra from Pd are caused by the decay of Pd-H bonds, from Pd-40Ag decay of Pd-H and PdAg-H bonds. During hydrogen saturation hydrogen traps are produced, in which hydrogen binding energy depends on an expedient of introduction of hydrogen.

The work is fulfilled in the International scientifically-educational laboratory "Technologies of Hydrogen Energetics" of Tomsk polytechnic university. This work was supported by the Government of the Russian Federation, project no. 11.G34.31.003

1.Nikitenkov N.N., Horuzhy V.D., Hashhash A.M. Proc. XIX Intern. conf. Ions–surf. interaction. VIP-2009, Zvenigorod, August, 2009. M: 2009, Vol.1. –P. 152-154.

LONG-RANGE EFFECT OF ION IMPLANTATION AND ITS INFLUENCE ON CHEMICAL COMPOSITION OF ROLLED COPPER-NICKEL FOILS.

Novoselov A.A., Bayankin V.Ya., Gilmutdinov F.Z.

*Physical-Technical Institute UrB RAS, Izhevsk, Russia,
less@fti.udm.ru*

Rolled foils of Cu₈₀Ni₂₀ and Cu₅₀Ni₅₀ composition (the latter had 100nm thick aluminum coating) had been irradiated with Ar⁺ and B⁺ under various ion current densities, ion energies and summary doses. Chemical composition and atomic structure of these samples were studied with X-ray photoelectron and Auger-electron spectroscopy (XPS and AES), Secondary-ion mass-spectroscopy (SIMS), Atomic force microscopy (AFM).

According to results of the study changes of microhardness of beamed side of foils depending of irradiation parameters correlate with changes of B concentration. Dose variation leads to much greater change of microhardness and chemical composition than variation of ion energy.

Studies of composition on un-irradiated side showed that ion implantation causes redistribution of material's components while foils are several periods thicker than depth of compositional and structural changes of material due to ion implantation, predicted by Lindhard-Scharff-Schiott's model.

It is suggested that this behavior is caused by initially non-equilibrium state of samples due to rolling. Ion implantation causes self-expanding structural changes: during irradiation of sample ions generate local thermal peaks. The excessive energy dissipates from these peaks in form of elastic waves and is enough for transformation of initial defect structure, such as de-blocking of dislocations and annihilation of different types of defects, which leads to generation of more excessive energy. This allows elastic waves to support themselves. As a result, we observe redistribution of material's components on un-irradiated side due to connection of atoms of specific type with flows of defects.

In conclusion, ion beam treatment of metallic systems with corresponding set of parameters could be used for intended modification of thin-measured products for creation of ultra-thin surface layers of given composition, structure and topography.

The study was done with financial support RFBR (project 10-02-96039_ural)

**HYDRODYNAMIC INSTABILITY IN METALS SUBJECTED
TO STRONG BEAMS OF CHARGED PARTICLES**

A.V. Orlov¹, V.L. Orlov², M.A. Gumirov³

1 Yugra State University, Khanty-Mansiysk, Russia, a_orlov@ugrasu.ru

*2 Polzunov Altai State Technical University, Barnaul, Russia,
a_v_orlov@mail.ru*

*3 Polzunov Altai State Technical University, Barnaul, Russia,
gumirov71@mail.ru*

This presentation proposes a model of the formation of hydrodynamic instability in a melted surface layer of solids subjected to irradiation. The key to the model under consideration is the convective movement of the liquid, caused by the gradient of temperatures. Convection leads to the formation of cells, similar to Bénard cells. The movement of the liquid at the boundaries of the cells is directed towards the surface, which may cause the formation of craters.

**RESEARCH MODIFICATION OF LIQUID HYDROCARBONS
IRRADIATED BY A NANOSECOND e-BEAM**

V.M. Orlovskii, Yu.V. Savinykh

*High current electronics Institute SB RAS, 2/3 Akademicheskii Ave.
634055 Tomsk, Russia*

*Institute of petroleum chemistry SB RAS, 3 Akademicheskii Ave. 634055
Tomsk, Russia orlovskii@loi.hcei.tsc.ru, yu-sav2007@yandex.ru*

Air or inert atmosphere irradiation of liquid normal alkanes C₅ - C₈ and of benzene by electron beam was carried out. Oxidation (in the air) or isomerization (in the inert gases) of liquid normal alkanes under electron beam was shown. Action of electron beam on benzene molecules in the air or in the inert atmosphere leads to polymers.

**INFLUENCE OF THE PULSED ELECTRON BEAM
TREATMENTS ON THE STRUCTURAL-PHASE CONDITIONS
AND RESIDUAL STRESSES IN THE TiNi SURFACE LAYERS**

**L. L. Meisner^{1,2}, M.G. Ostapenko¹, A.I. Lotkov¹, N.N. Koval²,
E.Yu. Gudimova³**

¹*ISPMS SB RAS, pr-t Akademicheskij 2/4, Tomsk, 634021, Russia,
(3822)286-819, artifakt@ispms.tsc.ru*

²*TSU, pr-t Lenina 36, Tomsk, 634036, Russia, (3822)286-819*

³*IHCE SB RAS, pr-t Akademicheskij 2/4, Tomsk, 634021, Russia,
(3822)491-544*

It is known that the treatment by the flows of the charged particles on the TiNi surface influences the near-surface properties of material. These treatments can lead to substantial changes of the structural-phase conditions in the material and appearance the residual stresses, localized in the modified near-surface layers.

By the purpose of this work is a study influence of the pulsed electron beam treatments on the structural-phase conditions and residual stresses in the TiNi surface layers by the X-ray diffraction method.

In the work was carried out the analysis of the X-ray diffraction patterns of samples after electron-beam treatments when the electron beam energy density was $E=15 \text{ J/cm}^2$, 20 J/cm^2 and 30 J/cm^2 . Investigation of the structure parameters have been studied by the methods of X-ray diffraction (XRD) analysis on the DRON-7 and XRD-6000 Shimadzu diffractometers using a symmetrical and asymmetric schemes. It is revealed, that after electron-beam treatments in all X-ray diffraction patterns have the high-temperature B2 phase and martensite B19' phase. The appearance of a martensite B19' phase can be caused by residual stresses induced by electron-beam treatments. According to obtained data, the maximum value of residual stresses $\sigma \approx 550 \text{ MPa}$ is observed in "fast-hardened" surface layer. In the substrate layers with the initial B2 structure residual stress does not exceed $\sim 100 \text{ MPa}$.

**CONTROLLABLE MICROSTRUCTURE GROWTH ON LIQUID
METAL SURFACES IN REACTIVE ATMOSPHERES:
EXPERIMENT AND THEORY**

**A. N. Panchenko, S. V. Alekseev¹, N. M. Bulgakova^{2,3},
D. E. Genin⁴, V. F. Losev⁵, and Yu. N. Panchenko⁶**

*High Current Electronics Institute SB RAS, Tomsk, Russia,
alexei@loi.hcei.tsc.ru*

¹ *High Current Electronics Institute SB RAS, Tomsk, Russia,
darok@sibmail.com*

² *Institute of Termophysics SB RAS, Novosibirsk, Russia, nbul@itp.nsc.ru*

³ *Optoelectronics Research Centre, University of Southampton,
United Kingdom*

⁴ *High Current Electronics Institute SB RAS, Tomsk, Russia,
dm_genin@vtomske.ru*

⁵ *High Current Electronics Institute SB RAS, Tomsk, Russia,
losev@ogl.hcei.tsc.ru*

⁶ *High Current Electronics Institute SB RAS, Tomsk, Russia,
ypancheno@sibmail.com*

Results of experimental and theoretical study of laser ablation of liquid metals is presented. Multi-pulsed irradiation of liquid metal samples (Ga, Ga-In alloy, In, Pb, Zn, Roze alloy, Wood alloy) was performed by ns pulses of Nd:YAG, N₂ or excimer lasers (2–20 ns, 1064, 337, 308, 222 nm, 3 J/cm²) and fs pulses of Ti:Sapphire laser (60 fs, 475 nm, 0,1–2,5 mJ, 0,3–5 J/cm²) in a vacuum or in different reactive gases (air, SF₆, NF₃, N₂). It was found that in chemically active gases microstructures are formed on the irradiated area with the rate of ~5–20 nm/pulse. The microstructure length can exceed 1 mm after ~200 laser pulses. The microstructure forms and sizes are easily to control. Comparison of the structure growth under the action of ns and fs laser pulses is made. The microstructures are found to consist of a thin metal oxide (nitride, fluoride) layer filled with liquid metal.

Theoretical analysis of ultrashort-laser-induced heating of liquid Ga has been performed on the basis of the two-temperature model. Similar to [1], it is assumed that laser light freely propagates through the oxide layer covering the target and is absorbed by liquid metal. Compared to ns laser pulses [1], in fs irradiation regimes the heat-affected zone is strongly localized resulting in much larger temperature gradients. In the experimental irradiation regimes, the surface temperature of the Ga target may reach an overcritical level that

culminates in phase explosion of a metal surface layer. However, before explosive ablation starts, a stress wave with an amplitude up to several GPa is formed which demolishes oxide covering. An overall scenario of microstructure growth with fs laser pulses is similar to that obtained for ns irradiation regimes [1] though the growth threshold is lower due to smaller heat-conduction losses.

This work is supported by Russian Foundation for Basic Research (Project No. 11-08-00427-a).

[1] N.M. Bulgakova, A.N. Panchenko, A.E. Tel'minov, M.A. Shulepov, *Appl. Phys. A*, 2010, Vol. 98, Issue 2, p. 393-400.

MODIFICATION OF THE STRUCTURE AND PROPERTIES OF SILUMIN BY COMBINED METHOD INCLUDING ELECTROEXPLOSIVE ALLOYING FOLLOWED BY ELECTRON-BEAM TREATMENT

E. A. Petrikova¹, Yu. F. Ivanov¹, V. E. Gromov², E.A. Budovskih², N.V. Bibik³, N.N. Cherenda³

¹*Institute of High Current Electronics SB RAS, Tomsk, Russia,*
elizmarkova@yahoo.com

²*Siberian State Industrial University, Novokuznetsk, Russia,*
budovskih_ea@physics.sibsiu.ru

³*Belarusian State University, Minsk, Belarus,*
cherenda@bsu.by

Aluminium alloys are widely used in the aircraft and automobile industry, tractor construction, in the manufacture of electrical equipment, rail and other equipment. Silumin (Al-Si) is the basis of most modern aluminum casting alloys, which is associated with a favorable combination of casting, mechanical and service properties. The evident shortcoming of silumin is the low strength characteristics, which restrict their range of application. Therefore, the task of finding and developing new promising techniques of modifying silumins providing increase wear resistance, microhardness and decrease coefficient of friction is very important.

Development of technology of hardening silumins recently is associated with the development of combined processes, including sequentially several methods of the modifications of the material.

The aim of the work was analyze the experimentally obtained results of the study of phase composition, structure and mechanical properties of surface layers silumins subjected to combined treatment, including electroexplosive alloying (Ti + B) followed by irradiation with high-intensity electron beam.

The object of study were samples of silumin with the following composition: 12.49% Si, 2.36% Mg, 0.6% Cu, 0.35% Ni, 0.3% Fe, Al balance, (at.%), samples were in the form of cylinders with a diameter of 10 mm and a thickness of 5 mm. Electroexplosive alloying is carried out on setup EVU 60/10 by electrical explosion of titanium foil thickness of 20 μ m. The pulse electron beam treatment of samples after electroexplosive alloying was carried out on setup "SOLO".

As a result of the research found that electroexplosive alloying leads to:

1) the formation of multilayer structure in the layer of 100...150 μ m thick;

2) to multiple (6-8 times) increase in the microhardness of the surface layer thickness of \sim 170 μ m (up to \sim 9 GPa).

Subsequent treatment of the surface by electron beam leads to the fact that:

1) microhardness of the formed layer is 3-5.5 times higher than that for initial material;

2) the degree of roughness of the surface layer is significantly reduced;

3) the coefficient of friction is reduced by 5-6 times compared to untreated samples.

Combined treatment including electroexplosive alloying (Ti + B) followed by electron-beam treatment has been carried out in the present work. The structure and phase composition of the silumin were investigated before and after treatment. It has been established that the combined treatment leads to dramatic refinement of Al grain structure and plates of Si and to the formation of nanocomposite particles of intermetallics and borides.

**FREAK STRUCTURES ON THE SURFACE OF COPPER TARGET
IRRADIATED BY ION BEAM**

**S. V. Polosatkin^{1,2}, A. V. Burdakov^{1,3}, E. S. Grishnyaev³,
S. G. Konstantinov¹, A. A. Shoshin^{1,2}**

¹ *Budker Institute of Nuclear Physics SB RAS, Novosibirsk, Russia,
s.v.polosatkin@inp.nsk.su*

² *Novosibirsk State University, Novosibirsk, Russia*

³ *Novosibirsk State Technical University, Novosibirsk, Russia*

Growth of freak tadpole-shaped structures on the copper target irradiated by deuterium ion beam has observed. The target originally destined for neutron generation represents bulk copper substrate covered by 3- μm titanium layer with 10-nm molybdenum intermediate. The target was irradiated by deuterium ion beam generated in Bayard-Alpert type ion source. Beam accelerating voltage was 35 kV; since in the such type of the source generates mostly D_2^+ ions, dominating fraction of ion beam has energy 17.5 keV/nuclear. Irradiation of the target to a fluence $10^{21}\text{cm}^{-2}/\text{s}$ with current density $50\ \mu\text{A}/\text{cm}^2$ causes complete etching of titanium layer. Stripped copper surface was subjected to a strong modification. Most interesting feature is growth of μm -size tadpole-shaped structures, localized in the cracks of the surface. RFA analysis of these structures showed extremely large (up to 60%at.) carbon content. Possible mechanisms of formation of the structures are discussed in the paper.

**PECULIARITIES OF HIGH-CURRENT ELECTRON BEAM
EFFECT ON THE STRUCTURE OF Ni-Ti ALLOY SURFACE
IMPLANTED BY KRYPTON IONS**

V. P. Poltavtseva, S. B. Kislitsin¹, N. N. Koval², K. V. Oskomov³

*Institute of Nuclear Physics, Almaty, Republic of Kazakhstan,
poltavtseva@inp.kz*

¹ *Institute of Nuclear Physics, Almaty, Republic of Kazakhstan,
skislitsin@inp.kz*

² *High Current Electronics Institute, Tomsk, Russia,
koval@hcei.tsc.ru*

³ *High Current Electronics Institute, Tomsk, Russia,
oskomov@lae.hcei.tsc.ru*

The paper represents the results of experimental research of the structure of Ni-Ti alloy surface with the shape memory effect, consistently modified by krypton heavy ions with the energies of 280 keV and 1.75 MeV/a.m.u. and high-current electron beam in the mode of surface layer melting. It was found that interaction of ⁸⁶Kr heavy ions of high energy with the polished surface of the alloy forms hemispherical convex structures (globules) up to 200 nm, associated with the accumulation of implanted ions, concentration of which increases with increasing implantation fluence. However, the process of globules formation is accompanied by the formation of structural elements typical for the sputtering process at low ($<5 \times 10^{15}$ ion/m²) fluences and is prevalent at high (10^{19} - 10^{20} ion/m²) fluences. In the case of ⁸⁶Kr ions of low energy implantation only the structures of surface sputtering can be observed even at the fluence of 10^{21} ion/m². It is established that the observed softening of the Ni-Ti alloy surface layer resulted from implantation of ⁸⁶Kr heavy ions of both energies is connected to sputtering of the oxide layer and occurrence of radiation-stimulated phase transition “martensite → austenite”.

After secondary treatment by high-current electron beam the almost uniform distribution of the globules of 15÷23 nm size is observed on the surface of the alloy implanted by ⁸⁶Kr ions of low energy and slight refinement of the globules and large heterogeneity in their distribution after implantation by ⁸⁶Kr ions of high energy. The additional softening of the Ni-Ti alloy surface is connected, apparently, with the melting of columnar structures, typical for martensite.

**COMPOSITION AND ELECTROCATALYTIC PROPERTIES OF
SURFACE LAYERS PRODUCED ON CARBON SUBSTRATES WITH
USE OF PLATINUM ION BEAM DEPOSITION FROM PULSED
ARC-DISCHARGE PLASMA**

V.V. Poplavsky, V.G. Matys, A.V. Dorozhko

*Belarusian State University of Technology, Minsk, Belarus,
vasily.poplav@tut.by*

Ion beam assisted deposition (IBAD) of platinum onto carbon substrates (glasslike carbon and carbon fiber paper AVCarb[®]) is carry out of neutral fraction of vapour and ionized plasma of pulsed electric arc. The deposition of a metal and the mixing of a precipitable layer with substrate surface atoms by accelerating ions ($U = 10$ kV) of the same metal were carried out from a neutral vapor fraction and the vacuum arc discharge plasma respectively of a pulsed electric arc ion source.

The microstructure and composition of the prepared layers were investigated using the SEM, EPMA, EBSD, RBS and XPS methods. The layers had amorphous atomic structure, almost repeat the structure of a carbon substrate, and their thickness obtained ~ 100 nm. The layers consist of the deposited metal, the carbon substrate material and oxygen. The content of deposited platinum in the layers is $\sim 10^{16}$ at. cm^{-2} .

The electrocatalytic activity of carbon-based electrodes with the prepared layers in the electrochemical hydrogen evolution and alcohol (methanol and ethanol) oxidation reaction obtained the activity of a platinum electrode.

**CORROSIVE PROPERTIES OF COATINGS PRODUCED ON
ALUMINIUM AND STEELS SUBSTRATES WITH USE OF
CHROMIUM ION BEAM DEPOSITION**

V.V. Poplavsky, V.G. Matys, I.M. Bely

*Belarusian State University of Technology, Minsk, Belarus,
vasily.poplav@tut.by*

Ion beam assisted deposition (IBAD) of chromium onto pure aluminium, aluminium alloy, carbon steel and stainless steel substrates is carried out of neutral fraction of vapour and ionized plasma of pulsed electric arc.

The composition and microstructure of the deposited coatings were investigated using the RBS, SEM and EPMA methods. The coatings consist of the deposited metal, the substrate material, as well as impurity of carbon and oxygen.

Corrosive properties of IBAD produced coatings were tested with use of electrochemical polarization method in 3% NaCl solution. Appreciable increase of corrosion potential was observed after deposition of chromium on aluminium and an aluminium alloy. It goes with the chemical nature of chromium as less active metal in comparison with aluminum. In case of stainless steel the corrosion potential has not changed almost after chromium deposition because of stainless steel already includes chromium in its content and character of processes defining corrosion potential after chromium deposition should not change. However observable sharp decrease in a corrosion current can be connected with change of a microstructure and composition of surface layer. Suppression or activation of the cathode hydrogen evolution reaction set conditions for corrosion resistance or damage of the coatings.

THREE-DIMENSIONAL MODIFICATION OF THE SURFACE BY THE PLASMA CATHODE ELECTRON GUN

A.G.Rau¹, S.I.Belyuk², I.V.Osipov

¹*TETA Corp., Loskutovo, Tomsk, Russia, rau@tetacom.ru*

²*Institute of Strength Physics and Material Science, Tomsk, Russia,
belyuk@tetacom.ru*

*Tomsk State University of Control Systems and Radioelectronics,
Tomsk, Russia, osipov@tetacom.ru*

There are technologies of three-dimensional modification of surfaces with use of an electron beam. By high speed regulation of position and power density of a beam on a processed surface it is possible to grow up quickly metal needles in height to six millimeters and diameter in the tenth shares of millimeter.

Grown-up structures can have a various form, the sizes, arrangement density on a surface. We used an electron gun with the plasma cathode for processing of various metal surfaces. Time of surface modification of 3x3 cm made no more than 3 seconds. Results of processing of various materials are given.

Technologies of 3D electron beam modification can be applied for:
creations of composite and ceramic coverings with high adhesion;
modification of surfaces for receiving one-piece connections metal-metal, metal-polymer without application of welding, glue, rivets and lateral connections;

creations of surfaces with the improved aerodynamic properties;
creations of surfaces with the improved hydrodynamic properties;
creations of surfaces with adjustable factor of reflection, absorption of electromagnetic radiations;

creations
of surfaces with the increased biological compatibility and biofunctionality.

EFFECT OF PLASMA PROPERTIES AND SET-UP GEOMETRY ON THE MEDICAL NEEDLE ION PLASMA SPUTTERING PROCESS

A.G. Remnev, K.V. Shalnov, K. Uemura

*Nagata Seiki Co. Ltd. 8-2Kamisuwa, Tsubame-shi, Niigata 98-5778, Japan,
aleksey_remnev@itac-j.co.jp*

Previously a novel method of the medical needles finishing was introduced. The method consists in ion plasma sputtering (IPS) process applied to an array of the medical needles in order to de-burr the needles.

The IPS method showed strong effect resulting in not only the burrs removal but also in the needle sharpening, surface smoothing and unique shape of the needles formation. It was shown that the penetrating performance of the needles was improved and one can expect reduction of pain sensation in patients receiving injection by IPS finished samples compared to the commercially available needles. The method was also found to be very promising in terms of mass-scale production as being potentially highly productive and bio-friendly technique.

Although the strong result has been achieved, there was no clear understanding of the mechanisms leading to the mentioned effects. Present work is devoted to the investigation of the IPS finishing mechanisms and the effect of plasma properties and needles array geometry on the resulting samples.

The IPS setup is based on a triode system with hot filament hollow cathode plasma generator, and negatively biased array of the needles.

Properties of the plasma, geometry of array and other parameters were varied. At each different set of the parameters SEM observation and penetration resistance measurement of the needles were carried out.

It was found that the sputtering speed was significantly reduced by adding even small amount of reactive gas into the working gas flow, it was also shown that needles shape, sharpness and surface roughness greatly depend on the amount of reactive gas in the mixture. For example, increase of air content in pure Ar from 0.25% (residual gas) to 7% inhibits growth of surface micro-structures such as micro-peaks and facilitates the surface smoothing effect (Fig.1). Microstructure development is also affected by the discharge current and the bias voltage.

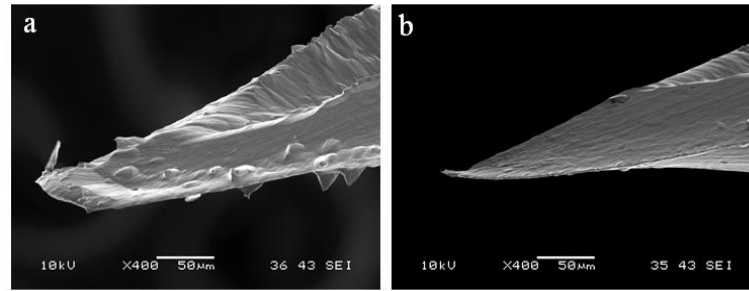

Fig. 1 IPS with: duration $T = 150\text{min}$, discharge current $I = 40\text{A}$, bias voltage $U = 400\text{V}$, total working pressure $P = 0.4\text{Pa}$. (a) $n = 0.025\%$ Air, (b) $n = 7\%$ Air.

EFFECT OF PARAMETERS OF PULSED ELECTRON-BEAM MELTING OF Al (FILM)/Ti (SUBSTRATE) SYSTEMS ON PHASE FORMATION AND PROPERTIES OF Ti-Al SURFACE ALLOYS

V.P. Rotshtein, Yu.A. Kolubaeva, X. Mei¹, A.B. Markov, E.P. Naiden², K.V. Oskomov, E.L. Pryadko, A.D. Teresov, I.A. Shulepov³, V.A. Shulov⁴

*Institute of High Current Electronics of SB RAS, Tomsk,
E-mail: rvp@lve.hcei.tsc.ru*

¹*Dalian University of Technology, Dalian, China,
E-mail: xxmei@dlut.edu.cn*

²*Tomsk State University, Russia, E-mail: naiden@elefot.tsu*

³*Tomsk Polytechnic University, Russia, E-mail: shulepovia@tpu.ru*

⁴*Moscow State Aviation Institute, E-mail: shulovva@mail.ru*

The results of the comparative studies of the phase formation regularities, hardening characteristics, tribological properties and oxidation resistance of the intermetallic Ti-Al surface alloys formed by repeated alteration of Al film (0.1-1 μm) deposition onto Ti substrate and pulsed liquid-phase Al/Ti mixing with intense low-energy ($\sim 15\text{ keV}$) electron beam of microsecond ($\sim 3\ \mu\text{s}$) [1] and sub-millisecond (100 μs) duration are presented.

It was found that the microsecond synthesis is effective approach to form the $\gamma(\text{TiAl})$ -based heat-resistant surface alloys. In turn, the sub-millisecond synthesis allows to fabricate the Ti_3Al -based surface alloys with increased wear resistance.

[1] Rotshtein V.P., et al. *Technical Physics Letters*. 37 (3) (2011) 226-229.

FORMATION OF THE CONDUCTIVE LAYERS WITH HIGH RESISTANCE IN THE SURFACE OF ALUMINA BY METAL ION IMPLANTATION

**K. P. Savkin¹, Ju. A. Burachevsky², A. G. Nikolaev¹, E. M. Oks¹,
A.V. Tyunkov², and G. Yu. Yushkov¹**

¹*Institute of High Current Electronics, Tomsk, Russia,
savkinkp@mail2000.ru*

²*Tomsk State University of Control Systems and Radioelectronics,
Tomsk, Russia.*

In the work the formation of conductive layers with high resistance in the surface of alumina by metal ion implantation have been made. With increasing of the implantation dose the surface resistance is reduced dramatically from 10^{12} Ohm/sq on 3 – 4 orders of magnitude. Some materials (*Mg, Zn, Zr, Sn, Ta, Pt, Au, Pb*) and carbon (*C*) of the vacuum arc cathode have been used for generation of the metal ion beams by MevvaV.Ru ion source. It was shown; that at high values of the implantation dose (from 1×10^{16} cm⁻²) the level of surface resistance is dependent from the material of implanted ions. The presented method of the reduction of surface resistance is an effective way for providing conditions for bleeding-off the accumulated surface charge which is induced as result of interactions with charge particles flows or dielectric polarization. It can be applied for increasing of the electric strength of surfaces of insulators in high-voltage devices.

THE METHOD OF SURFACE MODIFICATION OF METALS AND ALLOYS, INCLUDING OF THE ELECTROEROSION ALLOYING FOLLOWED BY ELECTRON-BEAM TREATMENT

**V.V. Shugurov, A.D. Teresov, Yu.A. Denisova,
E.A. Petrikova, Yu.F. Ivanov**

*Institute of High Current Electronics SB RAS, Tomsk, Russia,
shugurov@inbox.ru*

Operating life and stability of the most of machine parts depends on the physical and mechanical properties of the working surface where nucleate and develop the processes of wear.

Relatively small (5-20%) wear of the working surface, for example, in friction pairs of mating parts, exclude their further exploitation, while the residual mass and overall characteristics of parts in whole is close to nominal.

Consequently, the task of hardening the working surfaces are extremely urgent for the most branches of industry, also relevant analysis and development of technological options for strengthening treatment. The method of electroerosion alloying metal surface include transfer material on the operating surface by spark electric discharge.

Electroerosion alloying is almost always accompanied by the formation of high-relief surface. To reduce the surface roughness after electroerosion alloying of the most active use of methods based on mechanical effects to the modified surface (surface-plastic deformation, running the ball, non-abrasive ultrasonic machining, etc.). It should be noted that the application the methods of surface plastic deformation does not always lead to desired results.

So, at running by the ball, a slight exceeding (10%) required specific efforts of break, causes the appearance in the surface modified layer a micro-cracks that could lead to the destruction of parts.

Similar problems appear and at ultrasonic machining of the alloyed surface. Application of polishing after electroerosion alloying is not obviously possible, as, at least, 50 microns of a blanket, and a layer with the greatest extent of inoculation in this case leave. In a number of works for decrease in a roughness of a surface of the coating put by a method of electroerosion alloying, in the capacity of closing operation after alloying by a matching material the additional "soft" alloying which essence consists in spraying most surface prominent parts is lead. As a result there is a smoothing of combs and, hence, the surface roughness decreases.

The purpose of the present researches is development of a method of decrease a roughness of a surface of machine components at conservation of quality of a blanket (absence of microcracks, presence of a layer of the raised hardness, 100 %-s' continuity, etc.) Subjected to the electroerosion alloying, the inoculated layer based on additional bombarding radiation by a high-intensity electronic beam on installation "Solo". In the capacity of inoculated material used alloyed steels of different function; electroerosion alloying carried out on installation «ELITRON-22A», using an electrode from firm alloy VK6. Researches of structure, element and phase composition of a surface of alloying carried out methods of a scanning electronic microscopy and X-ray crystal analysis. Change mechanical and tribological properties analyzed, defining microhardness, wear resistance and coefficient of friction. Extent of a roughness of a surface of inoculation studied methods of optical interferometry.

Work is executed at a partial financial support of the Program of basic researches of Presidium of the Russian Academy of Sciences № 24.

**THE INFLUENCE OF EXPOSURE TO INTENSE PULSED
ELECTRON BEAMS ON NiCrAlY VACUUM-ARC COATINGS
ADHESION TO GAS TURBINE ENGINE BLADES
MADE OF GHS26NK ALLOY**

**V.A. Shulov¹, O.A. Bytzenko², D. A. Teryaev¹, V. I. Engelko³,
K.I. Tkachenko³**

¹*Moscow Aviation Institute, 4 Volokolamskoye shosse, A-80, GSP-3, Moscow
125993, Russia, E-mail: teryaev@mail.ru*

²*Chernyshev machine-building enterprise, 7 Vishnevaya street, 125362
Moscow, Russia, E-mail: teryaev@mail.ru*

³*Efremov Institute of Electro-physical Apparatus, 1 Sovietsky Avenue, Metal-
lostroy, St. Peterburg 189631, Russia, E-mail: engelko@niiefa.spb.ru*

This paper reviews the experimental data on influence of exposure to intense pulsed electron beams (IPEB) modes on adhesion of NiCrAlY protective coating to blades of GhS26NK alloy. It is shown that a intense pulsed electron beam of microsecond duration is a high-efficiency instrument for control of heat-resistance coatings adhesion to monocrystalline blades made of refractory nickel alloys. The application of IPEB at stage of physi-

cal-chemical condition modification of NiCrAlY protective coating allows performing of turbine blades quality control. It is established that during performing of turbine blades repair by means of IPEB, the surface cannot be prepared to deposition of new protective coating without sandblasting.

TEXTURE FORMATION IN SUPERFICIAL LAYERS OF TARGETS MADE OF VT9 ALLOY DURING THEIR IRRADIATION WITH INTENSE PULSED ELECTRON BEAMS

V.A. Shulov¹, O.A. Bytzenko², D.A. Teryaev¹, V. I. Engelko³, K.I. Tkachenko³, Yu.A. Perlovich⁴, M.G. Isaenkova⁴, V.A. Fesenko⁴

¹*Moscow Aviation Institute, 4 Volokolamskoye shosse, A-80, GSP-3, Moscow 125993, Russia, E-mail: teryaev@mail.ru*

²*Chernyshev machine-building enterprise, 7 Vishnevaya street, 125362 Moscow, Russia, E-mail: teryaev@mail.ru*

³*Efremov Institute of Electro-physical Apparatus, 1 Sovietsky Avenue, Metallostroy, St. Peterburg 189631, Russia, E-mail: engelko@niiefa.spb.ru*

⁴*Moscow Engineering Physics Institute, 31Kashirskoye shosse, Moscow 115409, Russia, E-mail: perlovich@mail.ru*

The main goal of this study was the exploration of texture formed in superficial layer recrystallized material of parts of VT9 alloy during their irradiation by intense pulsed electron beams with melt-inducing. With the methods of X-ray structure analysis and transmission electron microscopy it is shown that melt-inducing irradiation with intense pulsed electron beams causes formation in superficial layer with thickness of 20-25 μm of compression texture and finely dispersed lamellar microstructure. All this can cause sharp decrease of fatigue endurance during bending tests.

MODIFICATION OF CTRUSTURE AND MECHANICAL PROPERTIES OF TITANIUM ALLOYS BY COMPRESSION PLASMA FLOWS INFLUENCE

**V.I. Shymanski, V.V. Uglov, N.N. Cherenda, V.M. Astashynski¹,
A.M. Kuzmitski¹**

*Belarusian State University, Minsk, Belarus, 220030, Nezavisimosty ave., 4
e-mail: shymanskiv@mail.ru, uglov@bsu.by*

¹*B.I. Stepanov's Institute of Physics of National Academy of Science of
Belarus, Minsk, Belarus, 220072, Nezavisimosty ave., 68
e-mail: ast@imaph.bas-net.by*

The aim of the research is modification of the surface layer of titanium alloys by means of compression plasma flows influence on the “coating/substrate” system. A commercial pure titanium alloy was used as a substrate on which chromium, molybdenum or zirconium coating was deposited by vacuum-arc method. Thickness of the coatings was 1 – 2 micrometers. After this the formed systems were undergone by compression plasma flows in the nitrogen atmosphere (the residual pressure 400 Pa). The absorbed energy density was changed from 13 to 35 J/cm².

The described above influence by compression plasma flows allowed to form the surface layers in the titanium substrate alloyed with the atoms from the coating deposited previously. The research of spatial distribution of the alloying elements showed their deep penetration (up to 20 micrometers) and the uniform distribution along the melted layer, rising of absorbed energy density resulting in increase of alloyed layer and decrease of the alloying elements concentration. To describe the elemental composition evolution after compression plasma flows influence with the different absorbed energy density a convective-diffusion model was proposed. The model is based on the hydrodynamic motion of the melt that is described by Navier-Stokes equation. The main reason of deep penetration of alloying elements is supposed to be a convective mixing of the melting layer given rise by the initial pressure of the plasma flow. The results obtained from the model satisfactory agree with the experimental concentration profiles.

X-ray diffraction method allowed to find the formation of solid solution on the base of high-temperature phase of titanium (β -phase) in the modified layers in the case of the alloying with β -stabilized elements (chromium and molybdenum). Due to high cooling rate the melting layer the formation of solid solution β -Ti(Cr) and β -Ti(Mo) occurs at the chromium and molyb-

denum concentrations less than the ones characterized for the traditional (thermal) processes. In the case of zirconium alloying it was found α -Ti(Zr) solid solution formation.

The formation of the solid solutions as well as microstructure dispersion results in hardening of the modified layer. The mostly hardening was occurred after solid solution based on the cubic phase β -Ti(Cr) and β -Ti(Mo) formation. In this case the microhardness increase up to 6 – 7 GPa.

OPTIMIZATION OF STEEL SPARK CLEANING TECHNOLOGY

M.S. Slobodyan¹, G.E. Remnev², B.G. Shubin³, M.V. Zhuravlev⁴

¹*Tomsk Polytechnic University, Tomsk, Russia, mss@tpu.ru*

²*Tomsk Polytechnic University, Tomsk, Russia, remnev@hvd.tpu.ru*

³*Tomsk Polytechnic University, Tomsk, Russia, 777vbif777@sibmail.ru*

⁴*Tomsk Polytechnic University, Tomsk, Russia, zhuravlev-misha@mail.ru*

The process of spark cleaning of low carbon steel from the oxide film and other contaminants has been investigated. The influence of the energy parameters of the discharge and properties of the gas composition on the properties of the treated surface is shown. The most rational technological parameters to remove the maximum amount of oxides and other contaminants with the minimal degradation of the surface layer are determined.

**STRUCTURE, PHASE COMPOSITION, HEAT RESISTANCE,
PLASTICITY AND THERMAL STABILITY NANOSTRUCTURAL
BORIDES TRANSITIVE METALS LAYERS ON CARBON STEEL
S45 AFTER ELECTRON BEAM PROCESSING IN VACUUM**

**N.N. Smirnyagina, B.V. Radnaev, B.V. Radnaev, A.S. Milonov, D.E.
Dasheev**

*Institute of Physical Material Science SB RAS, Ulan-Ude, Russia,
ionbeam@pres.bscnet.ru*

In this report the structure and properties of surface layers obtained by electron beam borating are investigated.

The studies were carried out on samples, fabricated from carbon steel 45. The daub by thickness of 1 mm was deposited on previously prepared samples surface. The technical boron carbide B₄C or amorphous boron and the binding were entered into the daub composition. Treatment of samples was carried out within 2-5 minutes and the electron beam capacity of 150-300 W. The pressure in the working chamber did not exceed 2×10^{-3} Pa.

For comparison the diffusion borating was carried out at temperature 950°C within 4 hours in powder mixture containing 97 % B₄C and 3 % KBF₄, in the pressurized container. The layer thickness is made: after the diffusion borating 70-90 microns and after the electron beam borating 220 microns. The study of temperature dependence of microhardness has revealed features of borides layers structure. If in initial condition the borides layers received as result of diffusion borating, have higher hardness to comparison with in layers, obtained by electron beam boriding, at heating to temperature 800-900°C micro hardness becomes practically comparable.

Microstructure analysis (the optical microscope METAM PB-21) is established, that, since temperature 700°C in borides layers received as result of diffusion borating, begins to be formed the cracks. The crack origin is begun with a surface. The increase of heating temperature is resulted in propagation of a crack deep into layer and to her opened. In layers obtained by electron beam boriding the cracks are not found out.

A number of fragility has been determined. The number of fragility is determined on character of brittle failures incipient in an impression, which is formed at dip micro indenter in metal under a various loading 20-150 g. It is stabled, that layers received by electron beam boriding are more plastic, than after diffusion borating. Besides this layers have heterogeneous structure combining solid (friable) and more plastic structural components. Such com-

bination partly explains absence of thermal cracks at the borides layers heating up to high temperatures.

The boride layers fragility depends on phase composition. Is fixed, that the number of fragility of boride iron Fe₂B is less, than FeB, approximately twice. The aggregate fragility number is determined by phase composition of boride layer. On the X-ray data the surface layer after traditional borating consists of borides FeB, Fe₂B and boron cement carbide. Layer is two phases. The first zone is zone of borides. On a surface the needles of boride FeB, under them Fe₂B, then transition zone boron cement carbide settle down. Alongside with high fragility the boride two-phase layer has the brightly expressed propensity to shear. The shear occurs on a demarcation of phases. In a single-phase layer the shear is observed on boundary of continuous layer. Hence, single-phase boride layers are less inclined to shear.

The work is supported by the Russian Foundation for Basic Research (projects, 10-08-00918a and 12-08-98036-p_сибирь_a).

ESTIMATION OF THE STRESSES IN THE COATING GROWING THE DEPOSITION OF METAL IONS AND CARBON FROM THE ELECTRIC ARC PLASMA IMPULSE

S. N. Sorokova, A. G. Knyazeva¹, I. L. Pobal², A.R. Denizhenko³

*National Research Tomsk Polytechnic University, Tomsk, Russia,
s_sorokova@tpu.ru*

¹*National Research Tomsk Polytechnic University, Tomsk, Russia,
anna-knyazeva@mail.ru*

²*Physical-Technical Institute, National Academy of Sciences of Belarus,
Minsk, Belarus, i.pobol@gmail.com*

³*Physical-Technical Institute, National Academy of Sciences of Belarus,
Minsk, Belarus, denizh@list.ru*

One of the most widespread methods of reception nanocomposite coating is the method of magnetron deposition. But despite of progress in the field of designing nanocoatings actual there is forecasting problem of properties change during treatment. Coating growth occurs as a result of chemical transformations between particles adsorbed on the surface coming from an environment (from surrounding plasma, to the directed stream of ions, from a gas phase, a solution, solution etc.) in conditions of magnetron deposition.

This is companion by the release and absorption heat, mechanical stresses of field formation that determine properties of the growing coating. The final composition of characteristics is result from technological process or experiment but development of process of coating growing remains ambiguous. Simulation allows to investigate the growth process and to study, what role play that or other technological conditions in the dynamics of the process; to analyze the role of each physical factor separately.

For this purpose the mathematical model of coating growth at the magnetron deposition has been formulated and investigated. When the average mechanical stresses are evaluated the contribution of the stresses of thermal and diffusion–chemical nature taken into account. It was show that reaction kinetics on the surfaces plays in the stress evolutions no less role then relation between mechanical properties of growing coating and substrate.

The work was supported by the Russian Science Foundation, grant № 11-08-98027-r_siberia_a.

**EFFECT OF PULSED ELECTRON BEAMS EXPOSURE ON
STRUCTURAL AND PHASE STATES OF
SUBMICROCRYSTALLINE Ti-6Al-4V-H ALLOY**

**E. N. Stepanova, G. P. Grabovetskaya¹, I. P. Mishin¹,
A. D. Teresov², S. V. Grigoryev²**

*National Research Tomsk Polytechnic University, 634050, Russia, Tomsk,
Lenin Avenue, 30*

¹*Institute of Strength Physics and Materials Science of Siberian Branch
Russian Academy of Sciences, 634021, Russia, Tomsk,
Akademicheskyy Avenue, 2/4*

²*Institute of High Current Electronics of Siberian Branch Russian
Academy of Sciences, 634055, Russia, Tomsk, Akademicheskyy Avenue, 2/3*

An efficient way to improve the strength properties of metallic polycrystals at low homologous temperatures is the grain refining to submicron dimensions (grain size $d < 1 \mu\text{m}$). One of the methods of submicrocrystalline structure forming in titanium alloys is a combined method built upon reversible hydrogenation and hot plastic deformation. Hydrogen presence in titanium alloys at low homologous temperatures results in development of hydrogen embrittlement. Therefore it is necessary to remove

hydrogen from titanium alloys by the vacuum annealing of titanium alloys at temperatures above 873 K. Such dehydrogenation technique of submicrocrystalline titanium alloys promotes recrystallization and grain growth of the submicrocrystalline structure. At the same it is possible to decrease the hydrogen release temperature from titanium alloys by the electron beams exposure.

So the comparative study of evolution of the structural and phase states of a Ti-6Al-4V-H alloy by pulsed electron beams exposure at 523–723 K and vacuum annealing at 873 K is performed. Effect of process conditions of electron beams exposure and vacuum annealing on hydrogen release from Ti-6Al-4V alloy hydrogenated to the concentrations of 0,15–0,33 w.%, is studied.

The $\alpha \rightarrow \beta$ phase transformation in alloy is found to observe during dehydrogenation both with the use of vacuum annealing and pulsed electron beam irradiation.

Vacuum annealing at 873 K for 1 hour is shown to lead to hydrogen concentration decreasing down to the values, closed to the technical standards for this alloy and growth of submicron grains average size from 0,2 to 0,5 μm . While the temperature and/or annealing time are decreasing, the hydrogen concentration in alloy remains high than the values, corresponding accepted standards. Pulsed electron beam irradiation of Ti-6Al-4V-H alloy allows reducing the temperature of the active hydrogen release at 180 K and decreasing the time of dehydrogenation from the alloy twice as little. At the same time the level of internal stresses in submicrocrystalline structure of alloy decreases and average grain size increases from 0,2 to 0,3 μm .

**RADIATION-STIMULATED RELEASE OF HYDROGEN
FROM NANOCRYSTALLINE TITANIUM OXIDE
COATED BY ALUMINIUM OXIDE**

**V.S. Sypchenko, N.N. Nikitenkov, T.I. Sigfusson¹, Y.I. Tyurin, O.V.
Vilkhivskaya**

*Tomsk Polytechnic University, Tomsk, Russia, nikitenkov@tpu.ru,
Lenin Str., 30, 634050*

*¹University of Iceland, Innovation Centre, Keldnaholt, IS112,
Reykjavik, Iceland*

The research on hydrogen isotopes behavior in metals (or in other words metal-hydrogen systems) is important nowadays for at least three high tech industries: hydrogen, nuclear and thermonuclear power engineering. The present research has the most significant impact on hydrogen power engineering, as the problem of accumulation, storage and cold extraction of pure hydrogen from hydride accumulators has not been solved yet. Hydrogen can be present in metals at high concentrations, allocating in all the types of defects so that determining the mechanical, electrical and radiation properties of materials.

The aim of this study was to compare the release of hydrogen from nano-crystalline titanium alloy (Ti6Al4V(NC)) and from Al₂O₃ coating Ti6Al4V(NC) – (Al₂O₃/Ti6Al4V(NC)) when exposed to ionizing radiation. Such studies are necessarily valuable due to the practical use of these materials. Al₂O₃ coating is considered as the hindrance to the release of hydrogen from materials-accumulators a room temperature.

In this work the results of the research on hydrogen release from Al₂O₃/Ti6Al4V(NC) system under its exposure to accelerated electrons is presented. Electron energy was 40 keV, current density was ranging from 3 to 40 mA·cm⁻². The process of hydrogen release was controlled by mass-spectrometric method. Saturation of the samples with hydrogen was accomplished in a high-frequency low-temperature hydrogen plasma. Hydrogen saturation from plasma was performed under the following conditions: the pressure in the system was $\sim 5 \cdot 10^{-2}$ mm Hg, temperature was 450°C. Saturated initial and irradiated samples were investigated by thermo-stimulated gas release (TSGR) method, during linear heating of the samples (1°C/s), by recording and analyzing the TSGR temperature spectra. Hydrogen content in near-surface of the samples before and after irradiation was monitored by SIMS methods.

Possible mechanisms of hydrogen release stimulation during ionizing irradiation are considered in this report.

ELECTRON-BEAM SURFACE MODIFICATION OF MEDICAL SUPPLIES

**A. D. Teresov, Yu. Kh. Akhmadeev, N. N. Koval, Yu. A. Denisova,
E. A. Petrikova, A. V. Shteynle¹**

*Institute of High Current Electronics SB RAS, Tomsk, Russia,
tad514@sibmail.com*

¹ *Siberian State Medical University, Tomsk, Russia*

Proposed in 1951 by Ilizarov method of transosseous osteosynthesis has become a milestone in the development of injuries surgical of the limbs. Reliable immobilization, minimal invasiveness, the possibility of “bloodless” repositioning, mobility of the victims and other advantages have done this method the most promising among the employed in the surgical treatment. But, unfortunately, almost 60 years of experience in the use of transosseous osteosynthesis has confirmed that it is not without drawbacks. This is due to simultaneous mechanical and thermal traumatic effects of the spokes on bone and soft tissues of the limbs, besides frequent cases of spokes breaking inside the tissue during the process of rehabilitation.

According to statistics, about 23 million people in Russia are suffering from cardiovascular diseases, which constitute in the structure of mortality about 56.4%. One of the most common among the diseases of the cardiovascular system is coronary heart disease (CHD). The cause of CHD is insufficient blood supply of heart muscle due to narrowing of the lumen of the coronary arteries. Unfortunately, the use of drug therapy does not resolve the cause of the disease, but only adapts the body to the situation, setting up the heart to economical operation. From 1986 to restore the peripheral arteries using a metal frame mounted on a balloon - the stent. This device is a porous metal structure, which extends through the balloon and remains in the vessel, preventing complications and thrombosis. The starting material for the manufacture of the stent is most widely used stainless steel, nitinol, cobalt-chromium alloy, rarely titanium. As the technology of manufacturing methods are used precision laser cutting of thin-walled tubular preform. A neces-

sary condition for the applicability of the stent is a biocompatible of used material.

To reduce the traumatic effects of the spokes for the transosseous osteosynthesis, improve their corrosion and mechanical properties, as well as for finishing polishing of the surface in the production of intravascular stents has been proposed the technology of surface polishing with low energy submillisecond electron beam generated by an electron source with a plasma cathode based on the low-pressure pulse arc discharge, which is a part of the vacuum installation "Solo".

As samples of implants used standard spokes ($\varnothing 2$ mm, length 250 mm) for apparatus of transosseous osteosynthesis (Ilizarov apparatus) made of stainless steel 12Kh18N10T, and intravascular stents, made of thin-walled tubes (stainless steel 316L, the wall thickness of 0.1 mm, \varnothing 2-4 mm, length up to 25 mm) by using laser cutting.

Thus, after electron-beam action the surface roughness of transosseous osteosynthesis spokes has decreased by 2.5 times, intravascular stents by 2 times. In addition for the spokes were obtained a significant increasing of corrosion resistance and fatigue life.

QUENCH of the RADICAL-RECOMBINATION LUMINESCENCE of CRYSTALLINE PHOSPHORS by OXYGEN

**Yu.I. Tyurin, Yu.A. Sivov, I.T. Sigfusson¹, V.D. Khoruzhii,
E. Yu. Plotnikova, and L.I. Syumkina**

*Tomsk Polytechnic University, Tomsk, Russia, khoruzhii@rambler.ru,
Lenin str., 30, 634050*

¹*University of Iceland, Innovation Centre, Keldnaholt,
IS112, Reykjavik, Iceland*

The experimental results concerning the influence of molecular oxygen adsorption on inflammation radical-recombination luminescent kinetics (RRL) of crystal phosphorus excited by the hydrogen atoms are summarised. A hydrogen gas has been produced by electrolyse and purified from impurities by passing through a palladium filter. We have investigated powder phosphors with a narrow forbidden 3,56 eV zone: ZnS - selfactivated, ZnS Mn with a various activation concentration – ZnS-Mn [10^{-4} g/g] and ZnS – Mn [10^{-1} g/g], CaO-Mn crystal phosphors with a 7.7 eV forbidden zone .

It has been confirmed that even by room temperatures the molecular oxygen adsorption quenches luminescence of crystal phosphors either with the narrow or wide forbidden zone. At that, quenching is greater for crystal phosphors with a high activator concentration and crystal phosphors with a wide forbidden zone. An atomic oxygen adsorption does not produce any reversible luminescence quenching.

Luminescence quenching can be explained as follows:

1) Oxygen electron-acceptor molecules having been adsorbed on the surface of a solid generate the oxygen surface traps which produce the surface layer electrons and the probability of non radiation transposition to become smaller. Besides, the electrons produced in the conductivity zone in the process of adsorption and recombination of hydrogen atoms can recombine on the oxygen traps acting as radiationless transition recombination centres, and escape the radiation recombination process. At that, the luminescence intensity should drop out.

2) Interlocking the atomic hydrogen adsorption centres by the oxygen atoms is possible. It can slow down the reaction rate and lessen RRL intensity.

3) Oxygen molecules initially adsorbed interact actively with hydrogen atoms; at that the atomic hydrogen adsorption and the RRL excitement probabilities diminish.

We can suppose that interlocking the atomic hydrogen adsorption centres has to be more intensified for luminophors whose luminescent centres are excited while direct recombination upon luminescent centres (crystal phosphors with a great forbidden zone – CaO-Mn, phosphors with narrow forbidden zone but with great activator concentration – ZnS-Mn [10^{-1} g/g]).

Amplification of RRL quenching by atomic oxygen may be caused by formation of more strong (hence, weak reaction chemisorption forms) in comparison with adsorption by molecular oxygen. It has been proved that investigation of influence of gas adsorption on ignition kinetics gives possibilities to study a chemical reaction by its luminescence restoration process after adsorption. For instance, dumping irreversibility shows an adsorbed oxygen inhomogeneity.

The work is fulfilled in the International scientifically-educational laboratory "Technologies of Hydrogen Energetics" of Tomsk polytechnic university. This work was supported by the Government of the Russian Federation, project no. 11.G34.31.003

CHANGES OF T15K6 HARD ALLOY STRUCTURE AND PHASE COMPOSITION AS A RESULT OF NITRIDING BY COMPRESSIVE PLASMA FLOWS

**V.V. Uglov¹, V.M. Anishchik¹, A.K. Kuleshov¹, E.A. Krutsilina¹,
V.M. Astashynski², A.M. Kuzmitski²**

¹*Belarusian State University, Minsk, Belarus, e-mail:uglov@bsu.by*

²*The B.I. Stepanov Institute of physics, Minsk, Belarus,
e-mail:ast@imaph.bas-net.by*

Nitriding by heat treatment is known to be one of methods of hard alloy modification. In this study the samples of T15K6 hard alloy were nitrided by means of treatment by compression plasma flows (CPF) with submillisecond duration in nitrogen atmosphere. This method allows not only forming uniform melted layer but also to synthesize in this layer nitride phases providing hard alloy surface properties enhancement. Effect of surface layer nitriding as well as phase composition of the layer can be controlled by the change of such plasma parameters as energy density per pulse, number of pulses and nitrogen pressure. In this paper we investigated the influence of nitrogen pressure (3, 10, 30 Torr) in treatment by 5 pulses of CPF with energy density 22 J/cm² on phase composition and microhardness of T15K6 (WC-15TiC-6Co, wt. %) hard alloy.

X-ray diffraction analysis revealed that plasma impact resulted in melting of surface layer and its subsequent fast cooling and as a result a melted layer consisting mainly of (Ti,W)C solid solution was formed. WN and (TiC)_xN_y nitrided phases were also found. That is due to partial decomposition of carbides and diffusion of Ti and W to surface layer and enrichment of melt with nitrogen. At mentioned values of nitrogen pressure during CPF treatment phase composition was similar but at 3 and 30 Torr presence of WN nitride was more obvious opposite to 10 Torr. (TiC)_xN_y phase is otherwise. Formation of certain phase is defined by balance of CPF power and nitrogen concentration in chamber as we can suggest scattering of plasma particles on nitrogen atoms. The other reason can be different affinity of Ti and W for nitrogen. Microhardness of hard alloy was measured at different depth (0,8 - 3,3 (±0,2) μm) by change of load magnitude. It was established that microhardness increases in 2,6 times (~ 0,8 μm) at 3 Torr and with growth of nitrogen pressure to 30 Torr the depth of hardened layer increases.

STRUCTURE AND MECHANICAL PROPERTIES MODIFICATION OF INSTRUMENTAL MATERIALS SURFACE LAYERS BY COATING DEPOSITION AND HIGH INTENSITY ION BEAMS ACTION**V.V. Uglov¹, G.E. Remnev², A.K. Kuleshov¹, D.P. Rusalskiy¹**¹ *Belarusian State University, Minsk, Belarus, e-mail: uglov@bsu.by*² *Nuclear Physics Institute, Tomsk, Russia, e-mail: remnev@hvd.tpu.ru*

At the paper comparative studies of structure and mechanical properties modification of instrumental materials for metal and wood working by means of high intensity pulsed ion beams (HIPIB) action and deposition of the coating based on the molybdenum and titanium nitride limited solid solutions (Ti, Mo) N as well as combined influence of both influences types. The coatings were formed by condensation combined cathodic vacuum arc (CAVD) with bombardment by titanium and molybdenum ions in nitrogen atmosphere. High-energy radiation and heat action of HIPIB allows to change structure state and depth of modified layer by change of summary incident energy density. Increase of incident energy density from 8 to 240 J/cm² at HIPIB influence on coated hard alloy occurs by growth of pulses number 5, 100 and 150 at constant energy (320 keV) and ion current density (100 A/cm²).

At 5 HIPIB pulses radiation and shock action exceeds heat effect and results in formation of cracks with submicron- and micron-level sizes in instrumental materials layers (~1-2 μm) and coatings. It leads to significant degradation of materials tribological properties. Increase of pulses number to 100 allows to form full melted and alloying layers of coatings and substrate. For WC-TiC-Co hard alloys at the layer depth ~0,5 μm growth of the ratio of TiC-WC solid solution volume fraction to WC one occurs. Surface cell (part of micrometers) structure with the little part of micron-level size crack is formed. As it was found instrumental materials surface layer microhardness increases up to 1,5 times. Friction coefficient decreases in 1,5 – 2 times. Similar structure and mechanical properties changes occur in the case of (Ti, Mo)N coating.

Comparative analysis of heat effect of different HIPIB regimes on investigated materials surface layers was also carried out by numerical calculations of heat equation with regard to function of HIPIB energy absorption by materials and its nonuniform structure.

**NITRIDING OF TITANIUM ALLOY VT16 (Ti-3Al-4.5V-5Mo) IN
PLASMA OF NON-SELFSUSTAINED ARC DISCHARGE**

D. S. Vershinin, M. Yu. Smolyakova, T. N. Vershinina

*Scientific-educational and innovative Centre "Nanostructured Materials
and Nanotechnologies", National Research University "Belgorod State
University", Belgorod, Russia, e-mail Vershinin@bsu.edu.ru*

Nowadays one of the most promising applications of titanium alloys in medicine can be production of cutting, stabbing, peeling groups of medical instruments. But the low hardness and wear resistance of titanium alloy do not allow producing high-quality cutting tools. Low-temperature nitriding in plasma of non-self-sustained low-pressure arc discharge could be the method of improving surface properties of titanium alloys. In present work the influence of gaseous mixture composition and process temperature on structure and properties of modified layer of ($\alpha+\beta$) titanium alloy VT16 (Ti-3Al-4.5V-5Mo) after nitriding was studied.

The structural states of titanium alloy VT16 were – coarse grained (average grain size $\sim 7\div 8\ \mu\text{m}$), after preliminary thermal treatment (quenching with following tempering, martensite structure, average grain size $\sim 60\ \mu\text{m}$), ultra-fine grained (fibrous structure, average grain size $\sim 1.2\ \mu\text{m}$). The nitriding was performed on modernized ion-plasma installation NNV-6.6-II (Bulat) type in plasma of non-self-sustained low-pressure arc discharge at temperature 420°C during 60 minutes in mixture of gases argon-nitrogen and at temperatures $420, 500, 550$ and 650°C in gaseous mixture 40%Ar:60%N₂ during 40 minutes. Studies of structure and properties of modified layers were done with usage of optical microscope Olympus GX 71, scanning electron microscope Quanta 600 FEG, X-ray diffractometer ARL X'TRA, automatic microhardness tester DM-8B (Affri), automatic tribometer (High-Temperature Tribometer, CSM Instrument), precision contact profilometer SURTRONIC.

It is shown that a preliminary formed structure essentially influences on mechanical properties and thickness of modified layer. The structure refinement leads to greater increasing of surface microhardness with changing the gaseous mixture composition. Formation of surface nitride layer of ultra-fine particles (20-100 nm) leads to deterioration of tribological properties. Increasing the process temperature leads to recrystallization of ultra-fine grained titanium alloy with following decreasing of surface microhardness. Also formation of phases TiN_{0.3} and Ti₂N is observed with increasing process temperature.

LOW-TEMPERATURE NITRIDING OF AUSTENITE STAINLESS STEEL IN PLASMA OF NON-SELSUSTAINED ARC DISCHARGE**D.S.Vershinin¹, M.Yu. Smolyakova¹, I.M. Tregubov²**

¹ *Scientific-educational and innovative Centre "Nanostructured Materials and Nanotechnologies", National Research University "Belgorod State University", Belgorod, Russia, e-mail Vershinin@bsu.edu.ru*

² *Voronezh State Technical University, Voronezh, Russia*

The non-magnetic stainless steel 12Cr18Ni10Ti has high corrosion resistance, plasticity, impact strength and good weldability. This steel is widely used in medicine and food industry. But wear resistance of this steel is poor, so it cannot be used in tribotechnical systems. One of the methods of improving surface properties is low-temperature nitriding in plasma of non-self-sustained low-pressure arc discharge. It is well known, that during nitriding the increasing of hardness and wear resistance occurs, including as the result of chromium nitride formation. At the same time depletion of solid solution on chromium takes place that leads to decreasing of corrosion resistance and to deterioration of magnetic properties due to formation of ferrite phase.

In present work the influence of low-temperature nitriding parameters on structure and properties of modified layers of austenite steel 12Cr18Ni10Ti is investigated.

The nitriding was performed on modernized ion-plasma installation NNV-6.6-I1(Bulat) type in plasma of non-self-sustained low-pressure arc discharge at different temperatures (460, 480, 500 и 530⁰C) during 60 minutes. Studies of structure and properties of modified layers were done with usage of optical microscope Olympus GX 71, scanning electron microscope Quanta 600 FEG, automatic microhardness tester DM-8B (Affri), X-ray diffractometer ARLX'TRA, automatic tribometer (High-Temperature Tribometer, CSM Instrument), and precision contact profilometer SURTRONIC.

It was found that the low-temperature nitriding allowing increasing of surface microhardness more than 5 times (from 3 to 16.4 GPa). Increasing of nitriding temperature from 460 to 530⁰C leads to increasing of the chromium nitride content in the modified layer with simultaneous growth of magnetization magnitude of material. Optimal temperature of nitriding in plasma of non-self-sustained low-pressure arc discharge for improving surface properties of austenite steel 12Cr18Ni10Ti is the temperature 480⁰C. After nitriding

at this temperature the surface microhardness is 12.1 GPa, thickness of nitrided layer is 8 μm , wear rate decreases in three times and magnetic properties change insignificantly.

The changing of phase-structure composition of austenite stainless steel 12H18N10T after low-temperature nitriding at different temperatures in plasma of non-self-sustained low-pressure arc discharge is investigated. It is shown that ion nitriding results to increasing of microhardness and wear-resistance of the steel. Main parameters of nitriding process (temperature and gas mixture composition) that allow improving mechanical properties without essential changing of magnetic characteristics are defined.

Zr⁺ ION BEAM SURFACE LAYER STRUCTURE MODIFICATION IN 12CR1MOV STEEL AS A WAY TO IMPROVE ITS FATIGUE DURABILITY

**I.V. Vlasov^{1,2}, S.V. Panin^{1,2}, V.P. Sergeev², A.R. Sungatulin²,
M.P. Kalashnikov², and V.E. Panin^{1,2}**

¹*Tomsk Polytechnic University, 634050, Russia, Tomsk, Lenin Ave., 30*

²*Institute of Strength Physics and Materials Sciences SB RAS,
634021, Russia, Tomsk, Akademicheskii Ave., 2/4*

The majority of products and machine parts during their exploitation experience the impact of variable loads, which can give rise to their fatigue fracture. In doing so regardless the long history of study the problem of fatigue fracture and approaches to increase fatigue durability are of substantial importance.

In the current research specimens of heat resistant 12Cr1MoV steel intended for manufacturing parts of energetic equipment were examined. Ion nanostructuring of surface layer of the steel specimens was carried out with a help of high current vacuum arc source of metal ions UVN-0.2 "Quant".

Structure of surface layer after nanostructuring by Zr⁺ ion beam is represented by FeZr₃, FeZr₂ phases, as well as the ZrC carbides. The average size of the grains in the surface layer is 100-150 nm. Structural-phase microanalysis of the nanostructured surface layer has shown that the overall content of zirconium in the subsurface layer of the specimen makes about 14.2 %.

After the treatment ultimate strength of specimens under tensile tests has increased by 15 %, while the value of relative elongation is decreased by

19 %. Results of cyclic tension tests have shown that number of cycles prior to the fracture of the specimens with nanostructured surface layer is increased by 2-3 times. According to the testing data the fatigue life-time of specimens under cyclic alternating bending is increased due to nanostructuring of a surface layer by ~ 2 times.

It is found that the formation of the nanostructured surface layer increases the fatigue durability at cyclic tension tests. The authors associate this with the delay of time the main crack initiation due to suppression of strain induced relief formation which play the key role in propagation of a crack.

At cyclic alternating bending the main crack origination in specimens of both types happens at almost equal numbers of cycles that is associated with the periodic occurrence of tensile and compressive stresses in the surface layer. However, at the subsequent stage of main crack development the growth rate of the main crack is differing approximately in 2 times because of the nanostructured surface layer to block microcracks origin on the grain boundaries of the substrate. This result is consistent with data of distinction comparison for both fatigue crack growth rate at the cyclic tensile and bending. For the second case, the growth rate is several times less.

**ION-BEAM TREATMENT THE OUTER SURFACE OF FUEL
CLADDING FROM ZIRCONIUM ALLOYS
BY RADIAL ION BEAM Ar⁺**

B.A.Kalin, N.V.Volkov, R.A.Valikov, A.S.Yashin, V.N.Yalcev

*National Research Nuclear University MEPhI, Moscow, Russia,
e-mail: nvvolkov@mail.ru*

It is well known, that corrosion and erosion resistance, fracture resistance and wear resistance of fuel claddings are determined by structural-phase state (SPS) of the surface layers of zirconium alloys, which can be changed considerably by using radiation-beam technology (RBT).

With the aim of inhibition of corrosion processes and replacing of finish treatment (mechanical polishing), the experiments have been performed to identify influence of the different modes of ion treatment by radial beam of ions Ar⁺ with wide energy spectrum (cleaning, polish) on the claddings condition and their corrosion properties.

The experiments were performed on tubes, made from alloy E110 500 mm length ($\varnothing 9.15$). The modes of cleaning have been chosen according to the condition of spraying a 1 mm thickness layer, and the modes of polishing have been chosen according to the condition of maximal alignment of the surface relief. After treatment, the samples have been tested in an autoclave (350 °C, 16.5 MPa) for 1000, 2000 and 3000 hours.

The analysis of the surface condition has shown, that ion polishing decreases the surface roughness from 1.2–1.8 μm to 0.3–0.5 μm , and ion alloying of the outer surface with aluminum atoms decreases friction coefficient to 0.3.

Corrosion tests results has shown, that ion treatment usually reduces oxide film thickness, especially in the large-time autoclave tests. And the mode of the ion cleaning gives a greater reduction in the film growth in comparison with the ion polishing. In the linear approximation of the film thickness dependence on the time of testing $x(t)$ shows, that the rate of the oxide film growth after ion-beam treatment decreases from 0.0004 mm/h for of the sample in normal state (after mechanical polishing) to 0.0002 mm/h for the samples after ion cleaning and 0.00015 mm/h for the samples after ion polishing.

STRUCTURE AND PROPERTIES OF ZIRCONIUM-TITANIUM SURFACE ALLOY FORMED WITH A LOW-ENERGY HIGH-CURRENT ELECTRON BEAM

**E. V. Yakovlev, A. B. Markov, M. Bestetti*, M. F Brunella*,
V. I. Petrov**

*Institute of High Current Electronics SB RAS, 2/3, Akademicheskii ave.,
Tomsk, 634055, Russia, yakovev@lve.hcei.tsc.ru*

**Politecnico di Milano, via Mancinelli 7, 20134, Milan, Italy*

The paper is devoted to the characterization of structure and properties of Zr-Ti surface alloy formed with a low-energy high-current electron beam (LEHCEB) on Ti substrate. The surface alloy was formed by Zr film deposition by a magnetron sputtering followed by irradiation with a LEHCEB in a single vacuum cycle. The number of cycles of deposition-irradiation was 1, 2, 5, 10, and the thickness of the deposited Zr film in a single cycle was 0.5, 0.25, 0.1 and 0.05 μm , respectively. The number of LEHCEB irradiation

pulses in each cycle were $N=3$ and 10. SEM, EDX, GIXRD investigations and microhardness tests were used for characterization of properties of Zr-Ti surface alloy. It was shown that the formation of surface alloy leads to an increase in microhardness on the surface. Thus, in case of formation of surface alloy with $N=3$, the surface microhardness was half as much as that at the surface of titanium irradiated with a LEHCEB and twice as much as that at the surface of untreated titanium. In case of formation of surface alloy with $N=10$ the surface microhardness was twice as much as that at the surface of titanium irradiated with a LEHCEB and three times as much as that at the surface of untreated titanium. It has been established that the phase composition of the surface alloy is substantially differs from that for untreated and irradiated titanium.

MEASUREMENT OF IMPULSE FOR PULSED ELECTRON BEAM ABLATION

**Yang LI¹, Jie ZHANG¹, Xiaoyun LE¹, Gaolong ZHANG¹,
Xiao YU¹, Jie SHEN¹, Huaizhe XU¹, Weijiang ZHAO²**

¹*Beihang University, Beijing, 100191, China, zhangjie.jade@gmail.com*

²*Peking University, Beijing, 100871, China, wjzhao@pku.edu.cn*

Intense pulsed beam ablated target can generate reaction force, and it has a good application in micro-propulsion technology. The measurement of micro-impulse for pulsed electron beam ablated target is very important for the development of the micro-propulsion technology with intense pulsed electron beam. we use the method of pendulum combined position sensitive detector to measure the micro-impulse in $10^{-6} \sim 10^{-8} \text{N}\cdot\text{s}$. On the basis of this, we have a series of research on characteristics of the intense pulsed electron beam ablated metal target. And we get the regular understanding on beam parameters influence on recoil impulse.

PLASMA-IMMERSION ELECTRON SURFACE TREATMENT OF METAL SAMPLES

A. N. Zakharov, N. S. Sochugov, A.V. Kozyrev, V. A. Semenov¹

*Institute of High Current Electronics SB RAS, 2/3, Akademichesky ave.,
Tomsk, 634055, Russia, zare17@yandex.ru*

¹ *Tomsk State University, 36, Leninskii pr., Tomsk, 634050, Russia,
semenov_v@gmail.com*

This paper presents the experimental results of plasma-immersion electron surface treatment of metal samples. High-current pulsed magnetron discharge was used as source of plasma with density up to 10^{13} cm^{-3} . Voltage pulses with amplitude $U=2 \text{ kV}$ and duration $5\text{-}80 \text{ }\mu\text{s}$ were applied to samples. Optical and atomic-force microscopy were used to analyse sample surface morphology. It is shown that the melting of sample surface during plasma-immersion-processing leads to a decrease in surface roughness and grain size. The depth of the modified layer increases with the average density of energy absorbed by the sample.

SINTERING OF ALUMINA CERAMICS USING PLASMA ELECTRON SOURCE

**A. A. Zenin¹, A.S. Klimov¹, A.V. Kazakov¹, E.S. Dvilis²,
O.L. Khasanov², E.M. Oks¹**

¹*Tomsk State University of Control System and Radioelectronics,
Tomsk, Russia,*

²*Tomsk Polytechnic University, Tomsk, Russia
klimov@main.tusur.ru*

The results of experiments on the sintering of alumina ceramics by electron beam generated by plasma electron source at the forevacuum pressures are presented. Surface of the discs compacted from dry alumina nanopowder was irradiated. The discs were compacted by the technique of powerful ultrasonic action on powder during pressing. The sintering process was carried out at pressures in the range of $10\text{-}20 \text{ Pa}$, the electron beam with an energy of 10 keV and a current density of 5 A/cm^2 . It is shown that irradiation of the sur-

face of the compacts is possible to obtain samples with a density of 91,4% of single-crystal state. Optimal parameters of the electron beam and exposure time were determined experimentally. The regimes allowed obtaining the alumina ceramic samples sintered by the electron beam.

ARC PLASMA-ASSISTED NITRIDING OF HIGH-SPEED-STEEL

Y. H. Zhao, B. H. Yu¹, L. M. Dong², H. Du³

*Institute of Metal Research, Chinese Academy of Sciences, Shenyang, China,
yhzhao@imr.ac.cn*

¹*Institute of Metal Research, Chinese Academy of Sciences, Shenyang, China,
bhyu@imr.ac.cn*

²*Institute of Metal Research, Chinese Academy of Sciences, Shenyang, China,
lmdong@imr.ac.cn*

³*Institute of Metal Research, Chinese Academy of Sciences, Shenyang, China,
hdu@imr.ac.cn*

Low-pressure arc plasma-assisted nitriding technique is a newly developed plasma-assisted nitriding (PAN) processing, which has appeared very high nitrogen plasma reactivity and possibility to decrease the substrate temperature as much as possible. Unfortunately, the thickness of the nitrided region in high speed steels in almost all of the cases is thin. The thicker nitrided layer can endure more wear and better deal with the harsh environment in real application cases. In the present work, W18Cr4V high-speed-steel was modified by Low-pressure arc plasma-assisted nitriding process at temperature of 480 °C for 1 h with different gas composition (pure N₂ or N₂+Ar mixture). The structure, surface and cross-section micrographs, composition depth profile and microhardness profiles were analyzed using XRD, SEM, optical microscope, X-ray photoelectron spectroscopy (XPS) and microhardness testing. The results showed that a thick nitriding layer of about 50-80 μm. This layer was shown to consist of iron nitrides γ' -Fe₄N and W nitride WN, as well as a solid solution of N in α -Fe (α -Fe (N)). Furthermore, nitriding treatment provides an improvement in the microhardness profile. The thick nitrided layer provides the wide microhardness shoulder, which is especially benefit for industrial applications in the future.

EMISSION OF SiH IN FREE JET ACTIVATED BY ELECTRON-BEAM PLASMA

E. A. Baranov, S. Ya. Khmel

Institute of Thermophysics SB RAS, Novosibirsk, Russia, baranov@itp.nsc.ru

In the present study, we investigated the electron-beam plasma in gas jet of helium-argon-silane mixture by optical emission spectroscopy. The gas-jet electron beam plasma CVD method is used for deposition of amorphous, microcrystalline and epitaxial Si thin films. The method is based on the activation of a gas mixture jet by electron beam plasma and fast convective transfer of generated radicals by the supersonic free jet to a substrate.

Optical emission spectroscopy method is noncontact, nondisturbing, and rather simple one, but interpretation of measurement results is rather difficult. The method provides information on the emitting plasma components and on the electron energy distribution function.

In silane plasmas, the main emitting molecular silicon-containing component is the SiH radical in the $A^2\Delta$ state. Its emission spectrum, namely the $A^2\Delta - X^2\Pi$ transition bands provide information on the rotational temperature, which is an important characteristic of plasma emission components.

The rotational temperature of the $A^2\Delta$ state of SiH in a free jet of a mixture with argon and helium (Ar+He+SiH₄) activated by an electron beam is determined by comparing calculated and experimental spectra.

Rotational temperature on a distances 150 mm from the nozzle was 2100 K. Measurement error of temperature was 200 K. The temperature value greatly exceeds the gas temperature.

This indicates that the emission of radical SiH results from dissociative excitation of SiH₄ by electron impact, rather than the excitation of the radical from the ground state.

Metastable atoms of argon and helium can activate the silane molecule, but the values of the rotational temperature of the $A^2\Delta$ state of SiH is not more than 1800 K. Thus, these atoms do not participate in the activation process.

The assumption that the emission of SiH results from dissociative excitation of SiH₄ by electron impact is confirmed.

A SILICON FILMS DEPOSITION IN THE PROCESSES OF SiF₄ DECOMPOSITION IN PULSED GLOW DISCHARGE AND UNDER THE ACTION OF PULSED E-BEAM

V.V. Denisov, V.V Shugurov, A.A Kalushevich, V.V. Yakovlev, M.S. Vorobyov, Suslov A.I., Koval N.N.

*Institute of High Current Electronics SB RAS, Tomsk, Russia,
volodyadenisov@yandex.ru*

An experimental and theoretical study of SiF₄ decomposition process in pulsed glow discharge and under the action of pulsed e-beam has been performed. The experiments for SiF₄ decomposition in plasma chemical reactor (gas volume of 5 l) in a mix with hydrogen and without it at a room temperature under working pressures up to 1000 Pa were carried out. A dependence of silicon film deposition rate from pulsed glow discharge parameters and pulsed e-beam parameters on dielectric and conductive substrates in the process of SiF₄ decomposition has been studied. The electron beam has the electron energy of 150 keV, the beam current of 20 A, the pulse duration of 20-40 μs and the repetition rate of electron beam pulses is up to 100 Hz. The pulsed glow discharge has such parameters as voltage amplitude up to 1200V, current amplitude up to 1 A, pulse frequency up to 100 kHz, duty cycle up to 45%. The analysis of solid film compositions was carried out using EDAX -method. The possible mechanisms of SiF₄ decomposition under the action of electron beam and in the pulsed glow discharge using numerical technique were considered.

The research was supported by the Russian Foundation for Basic Research (Grant No. 11-08-98037-r_siberia_a).

**HEAT-RESISTANT OXIDE CERAMIC NANOPOROUS
COATINGS OBTAINED BY PULSE MICROPLASMA
PROCESSES ON ZIRCONIUM**

T. I. Dorofeeva, V.A. Mamaeva

*Institute of Strength Physics and Materials Sciences of the Siberian Branch
of the Russian Academy of Science, 2/4 Akademicheskii ave.,
Tomsk, 634021, Russia,
E-mail: dorofeevatomsk@rambler.ru*

In this work the method of formation of oxide ceramic coatings on zirconium surface by pulsed microplasma effect is shown. Microplasma oxidation has allowed creating the new unique oxide ceramic coating with the raised thermal stability because a nanoporous layer structure is formed. Pulse microplasma method in electrolytic solutions is one of most effective and economic forming way for obtaining ceramic multifunctional coatings on the alloys surface.

The purpose of the given work is formation of a heat-resistant oxide ceramic nanoporous coating on a zirconium surface by pulsed microplasma method.

As investigated samples there were samples of a copper. The titan is sprayed on a copper substrate (PVD method) then zirconium is sprayed step by step. The titan is necessary for prevention of a coating flaking off from a substructure when there is a difference in factors of thermal expansion of copper and zirconium.

This sample is exposed to pulse microplasma influence in an electrolyte solution. It is the closing and determining stage of processing. As a result of it there is a formation nanoporous zirconium dioxide on the surface.

On a surface the porous ceramic coating characterized by high adhesion and containing mainly a zirconium dioxide and connection from elements of material substrates (zirconium) and elements of electrolyte is formed.

The formed nanoporous ceramic coatings have been analyzed on thermal-cycle durability. Dynamics of transformations at thermo cyclic loading is reflected in surface photos.

As a result it is had low 50 % of the conserved coating on 80th cycle for oxide ceramic coating which formed in standard electrolyte with aluminum oxide; is had over 50 % of the conserved coating on 90th cycle for oxide ceramic coating which formed in standard electrolyte.

Thus, method of microplasma oxidation has allowed creating the new unique oxide ceramic coating with the raised thermal stability because a nanoporous layer structure is formed. Similar coatings can be used on interior sheeting in explosive motors for the space industry.

NITRIDE AND OXIDE FILM DEPOSITION IN HIGH DENSITY PLASMA OF A RADIO FREQUENCY PLASMA GENERATOR

Berlin E.V., Grigoriev V.U., Shchelkanov I.A.

*“Laboratory of Vacuum Technologies”, Zelenograd, Russia,
ebeam@e-beam.ru*

To provide high deposition rate of a dielectric film such as metal nitride or oxide, sputtering of a metal target in reactive gas mixtures is needed. “Laboratory of vacuum technologies, Ltd” has recently developed a new type of radio-frequency plasma generator (RFPG). This RFPG has a flat inductor coil. Inductor’s diameter is 125 mm, operating frequency is 13.56 MHz, and RF power can be varied between 200 W and 1500 W.

To provide stoichiometry of a deposited films, discharge properties dependency on gas mixture composition had been investigated. These dependencies allow one to control gas composition by measuring easily obtained quantities, such as target current and RF voltage.

Obtained data was used to develop oxide and nitride film deposition technology of aluminum, magnesium and titanium. Intense ion bombardment during deposition provided nice film structure which may be significant for some applications. Due to high electron temperature of noble gas plasma, sputtered metal atoms intensively ionize during their vote to substrate and may be additionally accelerated by biasing the latter.

Apart of reactive metal sputtering, thin insulation coating was PECVD. Samples of SiO₂ and α :C-H coatings with breakdown voltage over 500 Volts had been made.

The high density plasma of radio-frequency plasma generator is a versatile medium that allows very flexible management and precise control of reactive sputtering processes. It eliminates need in ion beam source and magnetron sputtering source, providing both intensive ion bombardment and target sputtering.

**SOLID OXIDE FUEL CELLS WITH THIN Ni-YSZ ANODES
FABRICATED BY MAGNETRON CO-SPUTTERING**

**I.V. Ionov¹, N.S. Sochugov¹, A.A. Soloviev¹, A.N. Kovalchuk¹,
A.O. Tcybenko¹, T.I. Sigfusson²**

¹*Department of Hydrogen Energy and Plasma Technologies, Tomsk Poly-
technic University, Tomsk, Russia, ionovigor@gmail.com*

²*Innovation Centre Iceland, Reykjavik, Iceland*

Ni-YSZ (YSZ – yttria-stabilized zirconia) films were fabricated by reactive magnetron co-sputtering of Ni and Zr-Y targets. The maximum deposition rate was $6 \mu\text{m}\cdot\text{h}^{-1}$. The oxygen flow and the DC power supplied to the Ni target were tuned to study the effect of the deposition conditions on the film properties and to obtain film with the required parameters. The chemical composition and the surface morphology of the films were studied. The columnar morphology was observed in the as-deposited films. Electrolyte supported solid oxide fuel cells (SOFC) with sputtered anode and brush painted $\text{La}_{0.7}\text{Sr}_{0.3}\text{MnO}_3$ (LSM) cathode were made to study the thin Ni-YSZ anode characteristics. Voltage–current curves of the electrolyte supported SOFCs with the brush painted and magnetron sputtered Ni-YSZ anode were compared. The maximum power density of the SOFC with the magnetron sputtered anode at 800°C was $210 \text{ mW}/\text{cm}^2$.

**INVESTIGATION OF TiC/a-C:H COATINGS DEPOSITED BY
MAGNETRON SPUTTERING OF TITANIUM IN Ar-C₂H₂ GAS MIX-
TURE, IONIZED BY ELECTRON BEAM**

**A.S. Kamenetskih, N.V. Gavrilov, M.V. Kuznetsov*,
A.V. Chukin**, E.V. Shishkina*****

*Institute of Electrophysics of the Ural Branch RAS, 106 Amundsen St.,
620016 Ekaterinburg, Russia*

tel.: (343) 2678778, Fax: (343) 2678794, e-mail: alx@iep.uran.ru

** Institute of Solid State Chemistry of the Ural Branch of RAS, 91,
Pervomaiskaya Sl., 620990, Ekaterinburg, Russia*

*** Ural Federal University, Institute of Physics and Technology, 19 Mira St.,
620002, Ekaterinburg, Russia*

**** Ural Federal University, Institute of Natural Science, 48 Kuybishev St.,
620026, Ekaterinburg, Russia*

Abstract - Composite coatings based on TiC particles with 3-8 nm grain size embedded in an amorphous hydrocarbon a-C:H matrix are deposited by pulsed magnetron sputtering of Ti-target in Ar/C₂H₂ atmosphere ionized by pulse (50 kHz, 10 μs) low-energy (100-400 eV) electron beam. The effects of acetylene flow rate, substrate bias and ion current density on composition and hardness of the coatings have been investigated by X-ray diffraction (XRD), X-ray photoelectron spectroscopy (XPS) and indentation tests. The hardness of coatings raised by 20% then ion current density increased by 30% due to increasing of electron beam current up to 1 A. Adhesive coatings with 5 μm thick, hardness of ~20-45 GPa and deposition rate of 1.4 – 1.9 μm/h have been obtained.

**PHASE COMPOSITION, STRUCTURE AND MICROHARDNESS
OF TiB₂ LAYERS ON CARBONACEOUS STEELS S20 AND U8A
AT PROCESSING BY POWERFUL ELECTRON BEAMS
IN VACUUM**

**Z.M. Khaltarov¹, A.S. Milonov¹, A.D. Teresov², N.N.Koval²,
A.P. Semenov¹, N.N. Smirnyagina¹**

¹-*Institute of Physical Material Science SB RAS, Ulan-Ude, Russia,
ionbeam@pres.bscnet.ru*

² - *Institute of High Current Electronics SD RAS*

Electron beam facing it is widely applied to obtain layered and gradient coatings on parts of any geometry and made of any alloy. The high electron beam power density (10^4 - 10^5 W/cm²), operation control of the beam energy characteristics, and small molten pool volume (10-20 mm³) provides a possibility to control the process by varying the integral temperature and heating and cooling rates of the pool over a wide range. The use of thermosetting powder mixtures as surfacing materials allows self-propagating high-temperature synthesis (SHS) by the electron beam.

In coating formation and its crystallization the big role is played by heat removal. Electron beam processing is characterized by high speeds of a heat-conducting path in the basic volume of a material $\approx 10^4$ - 10^9 K/c.

In work influence of input of a powerful electron beam on a coating structure TiB₂ generated during SHS in reactionary mixes/daub, containing TiO₂, B and C is studied. Electron beams with various ways of formation (pulse¹ or continuous²) were used and also a various combination of input, an arrangement of a surface of process able metal and heat removal were studied.

Coatings TiB₂ by thickness up to 200-370 microns is generated. The TiB₂ coatings have a complex structure of eutectic type with high solid particle TiB₂, and a dendrite inclusion which in the conditions of the directed crystallization is focused from the main axis of linear dendrites in a heat removal direction.

Reference

1. Koval N.N., Schanin P.M., Vintizenko L.G. *PTE*, 2005, №1, 35
2. Semenov A.P., Smirnyagina N.N., Sizov I.G. *Metal Technol*, 2001, № 4, 32.

The work is supported by the Russian Foundation for Basic Research (projects, 10-08-00918a and 12-08-98036-p_сибирь_a).

**OPTICAL PROPERTIES AND GROWTH RATES OF SILICON
FILMS SYNTHESIZED BY GAS-JET ELECTRON BEAM
PLASMA CVD METHOD**

S. Ya. Khmel

Institute of Thermophysics, SB RAS, Novosibirsk, Russia, khmel@itp.nsc.ru

Silicon thin films are deposited by gas jet CVD method with electron beam activation from mixture monosilane with diluent gas (argon, helium, hydrogen) on glass and stainless steel substrates. Optical transmission and reflection spectra are recorded for investigation optical properties and measurement thickness of silicon thin films with help of envelope method and PUMA code.

The spectral dependences of the refractive index and absorption coefficient of the films as well as their dependences on substrate temperature and hydrogen dilution of monosilane were found. The optical band gap was determined from the spectral dependence of the absorption coefficient of the films by high-energy part of the curve T_{auc} . The value of optical band gap decreases with increasing substrate temperature, which is associated with a decrease of the concentration of hydrogen in the film. Optical band gap increases with increasing hydrogen dilution of monosilane. Possible reasons of this behavior are increasing of the hydrogen concentration in the film or increasing of the degree of ordering in the material.

Silicon film deposition rate dependences on beam electron energy, beam current, mixture flow rate, gas-diluent flow rate, substrate temperature were taken. It is determined that deposition rate linearly increases with beam current increasing. Deposition rate increases with beam electron energy as well as with mixture flow rate increasing, and then reaches saturation. Addition of argon to the argon–silane mixture increased the deposition rate of silicon films, whereas addition of helium and hydrogen to the same mixture decreased the growth rate. It is shown that the process of silicon film deposition by this method from argon–monosilane mixture is primarily governed by fast secondary electrons, and argon dilution of mixture leads to increasing concentration of fast secondary electrons and increasing deposition rate of silicon films. Dilution of the initial mixture with helium causes a decrease in the deposition rate above all due to gas-dynamic behavior of the supersonic jet of the mixture of light and heavy gases. Dilution of monosilane or argon–monosilane mixture with hydrogen causes a decrease the deposition rate due to gas-dynamics effect and the etching effect of hydrogen atoms on the sur-

face of the growing silicon film. Deposition rate decreases with substrate temperature because of film density increasing.

**EFFECT OF HEAVY ION IRRADIATION ON STRUCTURE
AND PROPERTIES COATING BASED ON NITRIDE
OF TRANSITION METALS**

K.K.Kadyrzhanov, S.B. Kislitsin¹, V.V. Uglov²

*National Nuclear Center of Republic of Kazakhstan, Kurchatov, Kazakhstan,
kadyrzhanov@nnc.kz*

¹*Institute of Nuclear Physics of National Nuclear Center of Republic of
Kazakhstan, Almaty, Kazakhstan, skislitsin@inp.kz*

²*Byelorussian State University, Minsk, Byelorussia, uglov@bsu.by*

Nitrides of transition metals combining the physical properties of ceramics and metals have high hardness, wear and corrosion resistance, structure stability at high temperatures. This combination of properties allows considering materials with coating based on nitride of transition metals as perspective structural materials for advanced nuclear reactors. However, properties stability of such coatings under irradiation studied insufficiently. This prevents usage of transition metals nitrides as protective coating on structural materials in nuclear facilities.

Aim of present work is investigation of structure and physical-mechanical properties changes of thin $\text{Ti}_{50}\text{C}_{50}\text{N}$ and $\text{Ti}_{50}\text{Zr}_{50}\text{N}$ coating on carbon steel after heavy ion irradiation. Thin Ti-Cr-N и Ti-Zr-N coating is deposited on carbon steel substrate by magnetron sputtering and vacuum arc deposition.

The irradiation by xenon ions was carried out on the low-energy channel (channel of ECR- source, energy of $^{132}\text{Xe}^{+18}$ ions consists 20 keV/charge, i.e. ~ 360 кэВ,) and the high-energy channel (energy of ^{132}Xe ions consists 1.5 МэВ/a.e.m., i.e. ~ 200 МэВ) of the heavy ions accelerator DC-60 of Astana branch of Institute of Nuclear Physics. Respectively projective range of low energy xenon ions was ~ 100 nm, high energy xenon ions - ~ 10 microns. Experimental technique used for investigations was Roentgen diffractometry, scanning electron microscopy, Rutherford backscattering, atomic force microscopy.

Study of structure and surface morphology of samples with Ti₅₀Cr₅₀N and Ti₅₀Zr₅₀N coating directly after irradiation and after subsequent thermal treatment (annealing) in temperature range 400 – 800°C shows:

- No significant changes of phase structure of irradiated Ti-Cr-N coating on steel directly after high-energy Xe irradiation and after subsequent annealing in temperature range 400 – 800°C.
- High-energy Xe irradiation leads to appearance on the Ti₅₀Cr₅₀N coating surface of nano-scale intumescences. Two types of intumescences is observed: spherical – with dimensions of 10 ÷ 100 nm and more complicated shape. The last one was formed in the closely set place of incident Xe ion passage, so that zones of energy allocation at ions traveling through material overlaps. Most probable mechanism of intumescences formation is energy-release from incident Xe ions. Annealing of the irradiated samples lead to intumescences healing and recovery of surface structure.
- Irradiation by low-energy Xe ions Ti₅₀Zr₅₀N lead to lamination of Ti-Zr-N solid solution and formation of TiN phase.
- Irradiation by low-energy Xe ions does not result in bubble (void) formation or intumescences formation on the surface of Ti-Zr-N coating.

THE CONCEPTS OF DESIGN, THE FEATURES OF STRUCTURAL-PHASE AND ELASTIC STRESS STATE, PROPERTIES OF SUPERHARD AND ANTI-FRICTION COATINGS

A.D. Korotaev, S. V. Ovchinnikov¹, D. P. Borisov

National Research Tomsk State University, Tomsk, Russia,

korotaev@phys.tsu.ru

¹*Institute of Strength Physics and Material Science, Siberian Division RAS,
Tomsk, Russia, ovm@spti.tsu.ru*

The analysis of the design problems of nanocomposite coatings with special (in particular, superhard and low friction) properties was performed.

We have proposed the multi-element coatings as main objects of the search and new concept of their formation as self-organization of the microstructure on the stage island nucleation of growth. The physical principles of selecting compounds that provide the formation of thermally stable multi-

element nanocomposite coatings based on titanium nitride have been developed. These coatings offer the possibility of relaxation of stress concentrators and the minimum difference of elastic modules of the substrate and coatings to increase their strength and adhesion to substrate.

As an anti-friction coatings with low friction coefficient are promising nanocomposite coatings of titanium carbide – amorphous carbon and the compositions of $Ti_{1-x}C_xAl_y$ as shown by analysis of the literature. In these compositions occurs graphitization under stress field of the frictional interaction with the counterbody.

The plasma magnetron-arc equipment with integration in the reaction volume of eight vacuum plasma sources based on the magnetron vacuum and non-self-gas arc discharges was designed.

The experimental study of elemental composition, structural-phase and elastic-stress states of the coatings, obtained on the basis of principles developing nanocomposite coatings was carry out on the example of the composition Ti-Al-Si-Ni-Cu-O-N using fluorescence, X-ray diffraction and electron microscopy techniques.

The new feature of the substructure of coatings such as high curvature of the crystalline lattice of titanium nitride was revealed in the coherent scattering region size 10-30 nm with an angle of less than 5° misorientation in grains $d \leq 100$ nm. The values of the curvature in the areas of 10-15 nm reach $(150 \div 200)^\circ \mu m^{-1}$, whereas in areas of up to 30 nm value $(90 \div 120)^\circ \mu m^{-1}$. The excess density of one-sign dislocations corresponding to these curvature of the crystalline lattice amounts to $6 \times 10^{11} cm^{-2}$ when suitable level of local internal stresses $\sigma_{loc.} = 0.03 E$ (E – modulus of elasticity).

A wide range of values of the elastic lattice curvature from zero to $200^\circ \mu m^{-1}$ detected in individual nanocrystals up to 20 nm with the value $\sigma_{loc.} = E/200$. The level of strength properties of these coating correspond to superhard coatings ($H_\mu = 45$ GPa) at sufficiently high cohesive and adhesive properties as in the scratch-test level of acoustic emission remains constant at loads of up to 30 N.

THE AMORPHOUS-NANOCRYSTALLINE COATING CARBON-TiC ON THE SUBSTRUCTURAL STRENGTHENING TITANIUM

**A.D. Korotaev, D.P. Borisov¹, I.Yu. Litovchenko², A.V. Andreev¹,
V.Ya. Romanov¹, P.A. Terekhov¹**

Tomsk State University, Tomsk, Russia, korotaev@phys.tsu.ru

¹ *Tomsk State University, Tomsk, Russia, korotaev@phys.tsu.ru*

² *Institute of Strength Physics and Material Science, Tomsk, Russia*

Low wear resistance and not high strength properties of the titanium were considerably restricts it's using in tribological conjunction. On this account engineering of the coatings with low friction coefficient, high bearing strength, adhesive and cohesive has great scientific significance. Development of nanocomposite coatings on basis of amorphous carbon and nanophase carbide of titanium are presented oneself very perspective for solution of problems indicated above.

In this paper synthesis of such coatings on the substructural titanium by the plasma-magnetron systems "SPRUT" and "Legend" with using of generation of volume gas plasma and titanium and graphite cathodes in one-united technological cycle are performed.

The resulting coatings exhibited the values of microhardness about 20 GPa. The phase-structure state of the coatings is observed by X-ray structure analysis and electron microscopy methods.

EXTENDED MAGNETRON SPUTTERING SYSTEM PLASMA EFFECTS THAT LIMITING TARGET UTILIZATION

D. Kotov, A. Khissamov, V. Shiripov, A. Yasunas

Izovac Ltd., Minsk, Republic of Belarus, kotov@izovac.com

Coating technology on such a surface as wide - architectural and display glass, rolled materials were developed by magnetron sputtering systems (MSS) with a target lengths of up to three meters for in-line system. An important problem for such systems is to increase the target utilization. The main way is optimization the configuration of magnetic trap.

We have considered the main causes of the extended MSS low target utilization are remedies cross-corner effect and “end” effect. Results on the effect the configuration and amount of the magnetic field in the discharge area of the extended MSS to coefficient used of the target material. The analysis of the influence of nonuniformity of the magnetic field on the formation of anomalous sputtering area of the race-tracks was obtained.

**EQUIPMENT AND PROCESSES OF COMPLEX
ELECTRON-ION-PLASMA MODIFICATION OF MATERIALS
AND ARTICLES SURFACE**

N.N. Koval

*Institute of High Current Electronics SB RAS, Tomsk, Russia,
koval@opee.hcei.tsc.ru*

In the work vacuum ion-plasma and electron beam equipment and processes for modification of materials and articles surface, developed in Institute of high current electronics SB RAS are presented. They allow carrying out ion-plasma cleaning and activation of material surface and nitriding of surface layer with the subsequent coating deposition or electron beam treatment of a surface with its melting. It is possible to combine of that electron-ion-plasma processes changing phase-structural state (including nanostructurization), physical and mechanical properties of material surface in wide range.

PHYSICAL AND CHEMICAL CHARACTERISTICS FORMATION OF MULTICOMPONENT COATINGS IN ARC VAPOR DEPOSITION CONDITIONS.**M. V. Kripakova, A. G. Knyazeva¹, I. M. Goncharenko²***TPU, Tomsk, Russia, milla_ms@mail.ru*¹*ISPMS SBRAS, Tomsk, Russia, anna-knyazeva@mail.ru*²*IHCE SBRAS, Tomsk, Russia, ugor2012@sibmail.com*

Experimental data of the physical-mechanical characteristics for two systems hard nanocrystalline coatings $TiAlN$ and $TiAlSiN$ are presented. These coatings were deposited under similar conditions on the different samples materials. It was adjusted correlation between parameters W (упругое восстановление), H/E (упругая деформация разрушения), H^3/E^2 (сопротивление материала пластической деформации). Also the mathematical model of the dynamic growth coating with movement boundary was constructed. The task is calculated numerically and different schemes and variable time steps are used.

Deposition of nitride thin films passed on the modern processing plant *HNB-6.6-III* in plasma medium. Metal plasma was produced by sputtering of a composite cathode $Ti-Al$ system and $Ti-Al-Si$ system. Coatings were deposited on two types the polish samples of materials they are stainless steel $12Ch18N10T$ ($H = 3\text{ GPa}$, $E = 200\text{ GPa}$) and hard alloy $WC-8$ ($H = 16-17\text{ GPa}$, $E = 610\text{ GPa}$). Samples had low roughness $Ra \sim 0,02$. Thickness of coatings was tasted as result the optical data of the geometrical crater parameters abrasive wear on the *Nano-Hardness Tester CSM Instruments*. In turn the abrasive wear was a result of rotating sphere. Both hardness and elastic modulus were measured by the Oliver Pharr dynamic method on the samples. Adhesion strength was tasted on the Micro-Scratch-Tester CSEM Instruments. There was registration of physical parameters on this device (force and friction coefficient).

According to the experiment data, the growth rate of nitride coating corresponds to predetermined parameters of a vacuum-arc device. Device parameters for mathematical model construction are considered to be given. It is assumed that the rate of coating growth is determined by technological parameters due to the directed flux of aluminum and titanium positive ions from the cathode. Interstitial impurities penetrate plasma coating, thus nitride coating synthesis runs in the diffusion mode. Coating growth dynamics is described by one diffusion equation with different coefficients for the coating

and the substrate. In more complicated cases there is a system of diffusion equations with fluxes traverse and coefficients depending on the concentration of all elements. The task with a traveling boundary is calculated numerically and a time step is chosen according to external boundary hit into the block of a spatial grid. Consequently, both element concentration distribution and coating thickness are obtained at any time moment.

**SYNTHESIS, STRUCTURE AND CHARACTERISTICS
OF Al-Si-N COATINGS PREPARED BY VACUUM ARC
PLASMA-ASSISTED METHOD**

Yu. F. Ivanov, N. N. Koval, O. V. Krygina

*Institute of High Current Electronics SB RAS, Tomsk, Russia,
krygina_82@mail.ru*

In the given article the investigation of structural-phase state, elemental composition, physical, mechanical and tribological properties of multicomponent Al-Si-N coatings were carried out. The coatings were synthesized by a method of vacuum-arc deposition with plasma assistance. For optimization of deposition conditions the dependences of coating characteristics on such main parameters of synthesis process as dc and pulse bias voltage (U_b), duty factor of pulse bias (γ), discharge current of arc evaporator (I_d), and etc.

Furthermore, for the purpose of revealing of influence of additional ionization of working gas on formation of coatings deposited at various parameters of «PINK» plasmagenerator. In particular, that was investigated at increase of a discharge current of «PINK» in a range of 0-40 A. Structural-phase investigations by methods of transmission electron microscopy and x-ray analysis have shown that coatings are nanocrystalline with average grain size of 20.9 ± 7.3 nm. For Al-Si-N coatings the presence of following phases: h-AlN, Al, β -Si₃N₄, AlSi and τ -Al₂O₃, is observed. The main phase is h-AlN without the expressed texture. Al-Si-N coatings have low friction coefficient $\mu = 0,3$. Al-Si-N coatings are hard with *HV* about 30 GPa.

THERMAL STABILITY OF NANOCRYSTALLINE TERNARY SYSTEM COATINGS BASED ON TiN

**Yu. F. Ivanov¹, N. N. Koval¹, O. V. Krygina¹, S. Doyle²,
T. Baumbach², N. A. Timchenko³, R. M. Galimov³**

¹*Institute of High Current Electronics SB RAS, Tomsk, Russia,
krygina_82@mail.ru*

²*Institute for Synchrotron Radiation, KIT, Karlsruhe, Germany*

³*National Research Tomsk Polytechnic University, Tomsk, Russia*

One of the main characteristics for wear-resistant multicomponent nanocrystalline coatings is a thermal stability. It is connected by that usually such coatings are exposed to heating to temperatures $\geq 1000^\circ\text{C}$ during operation on open air or corrosive medium. Therefore the coatings should not only destruct during operation, but also to keep the unique properties. In the given work the investigations of thermal stability of coatings based on TiN deposited by vacuum-arc method with plasma assistance at evaporation of sintered cathodes have been carried out.

The results of a structural-phase state have been obtained by a method of x-ray analysis with the use of synchrotron radiations in a range of temperatures from T_r to 2000°C . It is necessary to notice that was carried out, both in situ, with the fixed speed of heating, and after coating annealing at certain temperature within an hour. Mechanical characteristics were measured by nanoindentation method.

Ti-Si-N SUPERHARD NANOCRYSTALLINE COATING SYNTHESIZED BY VACUUM-ARC DEPOSITION WITH PLASMA ASSISTANCE

Yu. F. Ivanov, N. N. Koval, O. V. Krygina, P. V. Moskvina

*Institute of High Current Electronics SB RAS, Tomsk, Russia
krygina_82@mail.ru*

In given article the experiments on deposition of superhard Ti-Si-N system coatings and investigation of their structural-phase state and element composition, physical, mechanical and tribological were carried out. The

coatings were synthesized by a method of vacuum arc plasma-assisted deposition at evaporation of sintered Ti-10at%Si cathode.

Variable parameters of coating deposition process were value of dc or pulse bias voltage U_b , duty factor of pulse bias γ , discharge current of arc evaporator I_d , and etc. By methods of transmission electron microscopy and x-ray analysis the average size of crystallites of the basic phase (δ -TiN) of Ti-Si-N coatings has been revealed. That equals $d = 10.1 \pm 4.0$ nm. I.e. the coating is nanocrystalline. The crystallites of the basic phase don't possess the allocated orientation. Additional element (silicon) forms nitride phase β -Si₃N₄ in a coating, and concentration of silicon by results of x-ray fluorescence analysis is $n_{Si}=2.0$ at.%. The hardness of Ti-Si-N coatings obtained in the given work, reaches 52 GPa, friction coefficient – 0.4, the maximum value of critical load - 15.4 N, and etc.

THE EFFECT OF ARC PLASMA-ASSISTED DEPOSITION PARAMETERS ON CHARACTERISTICS OF Ti-Cu-N COATINGS

O. V. Krysina, N. R. Nafikova

*Institute of High Current Electronics SB RAS, Tomsk, Russia
, krysina_82@mail.ru*

Systematic investigations of influence of deposition process parameters on physics and mechanical properties, element composition and structural-phase state of Ti-Cu-N coatings were carried out. The coatings were deposited by vacuum-arc method with plasma assistance. The material of cathode was sintered composite of Ti-12at%Cu composition. Varied parameters were: discharge current of arc evaporator (I_d), pressure of working gas (p), discharge current of “PINK”, bias voltage (U_b , γ), duration of deposition. On the basis of results of scanning and transmission electron microscopy, x-ray and x-ray fluorescence analysis, methods of micro- and nanoindentation, scratch-test, tribological researches the coatings with the best characteristics have been defined and therefore the optimum condition of their formation were allocated.

**MODELING OF THE PROCESS OF TIN COATING
MODIFICATION UNDER Al⁺ AND B⁺ ION BEAMS IMPLANTATION****O. N. Kryukova, A. G. Knyazeva¹, V. P. Sergeev², A. G. Lynyev³***ISPMS SB RAS, Tomsk, Russian, okruk@ms.tsc.ru*¹*Tomsk Polytechnic University, Tomsk, Russian, anna@ispms.tsc.ru*²*ISPMS SB RAS, Tomsk, Russian, retc@ispms.tsc.ru*³*ISPMS SB RAS, Tomsk, Russian, agl@ispms.tsc.ru*

The titanium nitride (TiN) coatings have been found the wide application to increase the wearlessness materials. Due to large increasing of volume interface fraction the coatings display at certain conditions unique combination of properties: high hardness, wearlessness, oxidative durability and, simultaneously, high coefficient of restitution and low friction coefficient. The high energy ion beam implantation after coating deposition is one of the effective approaches of directed changing of coating structure and composition. In this case, high concentration gradient of alloys arise in the coating surface layer, that leads to intense diffusing redistribution of elements into the coating depth.

The experimental investigations of the coating structure after treatment could not give comprehensive information on processes forming that or other structure. In this case the mathematical modeling could be useful. Technological process simulation is necessary for optimization of technology in future and for technological parameters choice. In this work the model had been modified taking into account the ion redistribution between the coating and base

It is assumed, that the titanium nitride coating had been deposited preliminarily on the armco iron specimen with small chromium fraction in his surface layer. The coating width can be varied in a wide range. Then the sample is treated by Al⁺ and B⁺ ion beam. During the treatment, ions implant in the surface coating layer and its heating. Due to the heat conductivity the base is heated also. At the experiment conditions the base can contact with the high-heat conductivity material that enable to regulate the cooling conditions. Additional heat losses are ensured by radiation. During treatment, elements redistribute, and different compounds and phases formation in the surface coating layer happen.

The thermal part of the problem is reduced to the solution of the heat balance equation. Diffusion part of the problem is solved numerically using

the implicit conservative different scheme and double-sweep method. The time steps for diffusion and thermal subproblems are agreed in compliance with specific rates of heat conductivity and diffusion processes.

During numerical investigation, the mole, atomic and mass fraction distributions are analyzed that is suitable to compare the theory with experiment.

Influence of ion beam density and coating thickness on the transition zone formation had been investigated in this work .

The results of numerical investigation conform qualitatively with experimentally obtained dependences of the concentrations distribution to the treatment process completion.

INVESTIGATIONS ON THE EFFECT OF NITROGEN LASER BEAM ON THIN COATINGS

**D. M. Lubenko¹, Yu. Kh. Ahmadeev¹, O. V. Krysina¹,
Yu. A. Chumakov²**

¹ *Institute of High Current Electronics SB RAS, Tomsk, Russia,*
lideru@gmail.com

² *Institute of Strength Physics and Materials Science SB RAS, Tomsk, Russia*

This paper presents the results of the experimental and theoretical studies on the effect of a nanosecond laser beam of the UV-band ($\lambda = 337$ nm) with energy up to 1 mJ on a surface of thin (0.5-5 μm) coatings (Ti, TiN, Al-Si, Al-Si-N) deposited on a glass substrate by the vacuum-arc method. The dependences of the effect of the explosive spark formation on the coating thickness, its properties and the conditions of the laser effect in atmosphere of different gases are presented on the basis of the obtained data. The mathematical model of the processes occurring in the coating/substrate system during laser irradiation is described; the value of the coating thickness at which there is its destruction with intensive sparking.

IONIC NANOSTRUCTURING OF COPPER SUBSTRATE AND THERMOCYCLIC STABILITY OF HEAT-RESISTING Si-Al-N COATINGS

**V. V. Neyfeld, V. P. Sergeev, M. V. Fedorishcheva,
M.P. Kalashnikov**

*Institute of Strength Physics and Materials Science of S B of RAS, Tomsk,
634021, Russia, Academicheskii, 2/4, retc@ispms.tsc.ru*

Heat-resisting coatings on the basis of silicon-aluminium nitrides are widely applied in gas turbine engines to decrease in effect of high temperature on the basic units of the combustion chamber, nozzle and working of turbine blade and etc. Essential difference of coefficient of thermal expansion of a ceramic coating and a metal substrate, their elastic characteristics, etc. is causes development of strong thermal, mechanical, phase stresses in heat-resisting coatings during use of. The relaxation of these stresses can cause intensive cracking of ceramic coatings with the subsequent themshelling.

One of key parameters defining reliability and durability of heat-resisting coatings is adhesion to a metal substrate. To raise adhesion before deposition of a coating a surface of substrate process by various methods. Ionic-beam processing of metal substrates is perspective in this direction. It can provide the effective matching of crystal lattices of materials with optimum distribution of elastic stresses along the interface. It is shown that bombardment of a copper substrate by Zr^+ ions beams leads to increase in adhesion and crushing of structure of heat-resisting Si-Al-N coatings. An ionic-beam processing can change fields of elastic stresses in the on interface, also to form a microstructure and change chemical and phase composition in surface layer of substrate. So in the present work behaviour of influence of each of these factors on thermocyclic durability of heat-resisting Si-Al-N coatings are investigated.

Nanostructuring of surface layer of a copper substrate was carried out by ions Ti^+ flux at different operating modes of arc ionic source. Deposition of coatings was carried out by pulse magnetron method (50kHz) using the mosaic target consisting of the aluminium basis and silicon inserts. The chemical compound and a structurally-phase state of surface layers of a copper substrate and a coating were studied by methods of microX-ray spectrum analysis, and scanning and transmission electronic microscopy of high resolution.

Thermocycling tests of systems “coating-nanostructuring surface lay” in the temperatures area of 293÷1273 K have shown that its thermocyclic stabil-

ity is defined not only a structurally-phase state of a coating but substantially morphology and a structurally-phase condition of surface lay of substrate. Physical laws of thermocyclic stability of coatings as function of modes of ionic-beam processings are established.

**INVESTIGATION OF THE FEATURES OF STRUCTURAL STATE
IN THE AREAS OF DEFORMATION AND FRACTURE IN
SCRATCH TESTING AND NANOINDENTATION DOPED COAT-
INGS BASED ON TITANIUM NITRIDE**

S. V. Ovchinnikov, A. D. Korotaev¹, Yu. P. Pinzhin, S. V. Popov¹

*Institute of Strength Physics and Material Science, Siberian Division RAS,
Tomsk, Russia, ovm@spti.tsu.ru
National Research Tomsk State University, Tomsk, Russia,
korotaev@phys.tsu.ru*

The urgent stage of the synthesis of wear resistant coatings is to determine the features of modification of their structural-phase and elastic-stressed state in the areas of deformation and fracture. In this regard, we have studied the structure of the material in the areas of nanoindentation and scratch testing of coatings Ti-Al-Si-Cu-N. A gradient of the element, the phase composition and structure across the thickness of these coatings can provide the high adhesive strength, fracture toughness and low coefficient of friction, as necessary properties of wear-resistant coatings.

Coatings were prepared in argon and nitrogen environment by magnetron sputtering targets of titanium (VT 1-0), copper and alloy Al-Si at temperature of deposition nearly 150 °C. Coatings compositions correspond to high (a total of about 35 at. %) and low (a total of less than 5 at. %) content of alloying elements (Al, Si, Cu) and nanocrystalline or submicrocrystalline structure respectively.

The mechanical properties (hardness, Young's modulus) of coatings were measured by nanoindentation. A fracture stress intensity factor (K_{1c}) and the specific work of the adhesive delamination were estimated. The features of the structural state after deposition and in zones of deformation and fracture of scratch were defined by method of dark-field electron microscopic analysis of bending-torsion of the crystal lattice. It is shown, that deformation in the marked zones leads to the disappearance of texture coatings, the

growth of bending-torsion of the lattice and the discrete local misorientations. The estimates of the values of local residual elastic stresses were performed on the bases of structure models representations the detected features of the structural state. We discuss possible mechanisms of modification of the structure in the deformation zones based on these results.

DEPOSITION OF TiC/a-C:H COATINGS BY ACETYLENE DECOMPOSITION IN TITANIUM ARC PLASMA

S. A. Plotnikov, D. R. Emlin¹, I. S. Trachtenberg, N. V. Gavrilov¹

IPM UB RAS, Yekaterinburg, Russia, sp555555@mail.ru

¹*IEP UB RAS, Yekaterinburg, Russia, erd@iep.uran.ru*

Method of TiC/a-C:H – coating deposition by ionization of C₂H₂ + Ar gas mixture in titanium DC arc plasma is realized in production unit UVNIPA 1-001 intended for DLC deposition by pulsed arc with a graphite cathode.

Chemical composition of the coatings is varied by change of acetylene pressure at fixed arc current 60 A. The maximum of coating microhardness (~15 - 20 GPa) is achieved at pressure ~ 0.06 Pa, at that titanium contents being respectively equal to ~ 45 at. %.

A pulsed bias voltage (50 kHz) enhances the microhardness, shifts its peak values towards the area of higher pressure (-100 V, ~0.3 Pa) and leads to appearance of up to 4 at. % argon in the coatings. Coefficient of friction against steel for the coatings makes 0.1-0.2 at carbon content ~ 45 - 60 at. % and grows up to ~ 0.35 if the content of carbon exceeds ~ 60-70 at. %.

**MULTICOMPONENT NITRIDE COATINGS DEPOSITED AT
VACUUM ARC EVAPORATION OF POWDER CATHODES**

**G.A. Pribytkov, V.V. Korzhova, I.A. Firsina,
E.N. Korosteleva, A.V. Gurskih**

*Institute of Strength Physics and Materials Science,
Akademicheskyy ave., 2/4, Tomsk, 634021, Russia,
Phone:(3822) 286-967, Fax:(3822) 492-576, E-mail:gapribyt@mail.ru*

Some decades ago titanium nitride (TiN) films has been the most widely used as a protective and wear resistant coatings. The most often they were used for metal cutting tools. However, TiN starts to oxidize rapidly at above 500⁰ C. During last two decades a novel multicomponent nitride coatings have been developed. The coatings are deposited on the substrate from multicomponent plasma containing ions of nitride-forming metals (Ti, Al, Zr, Cr etc.) and some metalloids (Si, B) or the metals that don't form nitrides (Cu, Ni, Y). Multicomponent nitride coatings, as a rule have a larger hardness as compared with that of simple nitrides. Doping of some elements (Al, Cr, Si) to basic nitride forming metal results in the lower friction coefficient and more high oxidation resistance of multicomponent nitride coatings. As a result a durability of the tools with the coatings rises.

To get necessary elemental content of the multicomponent nitride coating two or more targets (cathode) are common used. A substitution of several cathodes with one, containing all necessary elements in an optimum ratio results in a more simple equipment design and improves plasma homogeneity.

Powder metallurgy technology including a cold compaction and a subsequent sintering is considered to be the most promising for preparation of the multicomponent (composite) cathodes. The technology of hot compaction of multicomponent powder mixtures is an alternative way.

The authors of the present work have used both of above mentioned powder technologies for fabrication of powder composite cathodes Ti-Cu, Ti-Si, Ti-Al, Ti-Al-Si, Al-Cr, Al-Cr-Si, Al-Cr-Ti. Technology regimes of cathode fabrication provided minimum porosity and optimal structure of the cathode materials were developed. Experimental cathodes were tested at the vacuum arc and magnetron sputtering in nitrogen gas medium.

Deposited nitride coatings were investigated by SEM and X-ray diffraction methods. The coatings have a nanocrystal structure and the hardness 1,5-2 times more, then TiN coating, deposited by vacuum arc evaporation of pure Ti in nitrogen gas medium.

POLYMER FILMS WITH LOW-E COATING TO REDUCE HEAT LOSS THROUGH WINDOWS

**S.V. Rabotkin, N.S. Sochugov, N.F. Kovsharov,
A.A. Soloviev, K.V. Oskomov**

*Institute of High Current Electronics SB RAS, 2/3, Akademichesky ave.,
Tomsk, 634055, Russia, rabotkin@yandex.ru*

This paper presents the experimental results on depositing a multilayer low-e coating with oxide-metal-oxide structure on a PET film by magnetron sputtering. The $\text{TiO}_2/\text{ZnO:Ga}/\text{Ag}/\text{ZnO:Ga}/\text{TiO}_2$ coatings were suggested to obtain a high water-resistance and a capability to be used outside a sealed double-glazed window. The optimal thickness of the coating layers was determined. It allowed obtaining the best transparency in the visible spectrum to reflection in the infrared spectrum ratio. It was shown that the low-emission coatings based on Ag have the transparency in the visible spectrum of 82% and reflection in the infrared spectrum of 93%. The heat engineering investigation of translucent models with the low-emission film was carried out. It showed the growth of resistance to heat transfer up to $0.73 \text{ m}^2 \cdot ^\circ\text{C}/\text{W}$ for the windows OP-15-13.5 with the low-emission film. The resistance to heat transfer of the windows without the film was $0.38 \text{ m}^2 \cdot ^\circ\text{C}/\text{W}$.

MULTILAYER HEAT-SHIELDING COATINGS ON THE BASIS OF Zr-Y-O/Si-Al-N WITH HIGH THERMAL-CYCLE DURABILITY

V.P. Sergeev, V.E. Panin, R. N. Rizakhanov¹, A. S. Koroteev¹

*Institute of Strength Physics and Materials Sciences SB RAS, Tomsk, Russia,
vserg@mail.tomsknet.ru*

¹*SSC «Keldysh Research Center», Moscow, Russia, kerc@elnet.msk.ru*

The up-to-date requirements to operational performances of the rocket engine correcting a direction of flight a problem of development of coatings on inside of nozzles which would possess not only high heat-shielding performances but also high thermal-cycle stability is urgent. The solution of this

problem is the extremely important due to necessity to use rocket engine many a time in long-term space flight.

In this article the main principles of formation of nanocomposite multi-layer heat-shielding coatings on the copper substrates with high thermal-cycle stability were formulated. They consist in the following:

- it is necessary to form a fine cellular interface and a "chess"-like stress distribution by means of an ion sputtering in the superficial layer of a substrate, to create high concentration of the fine concentrators of stress uniformly allocated on a surface, to decrease a temperature linear expansion coefficient (LEC) using an ion surface alloying;

- to form a relaxing first layer on a nanostructured substrate with high strength and crack growth resistance and thermal shock stability, low value LEC close LEC of surface layer by means choice of ceramic composition and a mode of an ion-magnetron sputtering;

- An upper functional layer of a coating should have low thermal conduction, globular structure and sufficient thickness to provide effective decrease in temperature to create necessary operating conditions to relaxation lay. It should possess high oxidizing stability, high adhesion to an adjacent lay and ability to resists to crack formation.

These coatings were produced by combined ionic-magnetron method of deposition and nanostructuring of copper substrate surface by a high-current flow of heavy metal ions of the heat-resistant oxide and nitride of ceramic materials

Researches of structurally-phase states and distributions of elements on depth of different layers of a multilayer coating and a superficial lay of a copper substrate were carried out using TEM SEM, X-ray and AFM, MSCI

It is shown, that a coatings deposited on the basis of the developed principles and consisted of the nanocomposite ceramic layers Zr-Y-O and Si-Al-N as deposited on the nanostructured superficial layer of a copper substrate, have thermal-cycle stability about 90-100 cycles in a temperature interval 293-1273 K. It result is high and exceeds the best effects produced on samples of heat-shielding coatings at 6-10 time.

Carrying out of a firing test of these coatings at the Keldysh Research Center on a plasma generator of a megawatt class an efficiency of these coatings has confirmed as in steady conditions of action of a stream of plasma with power of $2,6 \cdot 10^7$ W/m² and temperature 4000K so in a mode of a heat cycling. It is shown, that middle working temperature of multilayer nanocomposite heat-shielding coatings is 1280K, and their effective heat conductivity factor is 7 - 14W/m·K. It is established by SEM that the

nanocomposite multilayered heat-shielding coatings stand the firing tests without failure of continuity, exfoliation and fractures.

**FORMATION OF GRADIENT COATINGS ON THE BASIS
OF Ti–Al–B–N SYSTEM BY METHOD OF MAGNETRON
DISPUTTERING AND ION BEAM BOMBARDMENT**

**O. V. Sergeev, V. P. Sergeev, M. V. Fedorischeva, M. P. Kalashnikov,
A. V. Voronov, A. R. Sungatulin**

*Institute of Strength Physics and Materials Science SB RAS, Tomsk, Russia,
e-mail: tehnovak@ispms.tsc.ru*

Today the huge quantity of researches is devoted to multi-component, polyphase nanocrystalline coatings based on Ti–N system, in particular, polyphase coatings based on nitrides, borides, carbides of titanium, aluminum, chromium, etc. Due to a significant increase in the volume fraction of grain boundaries, such coverage may acquire high tribological and mechanical properties. Ion beam processing allows the synthesis of coatings with varying on depth of structural and phase composition, the so-called gradient coatings. The bottom layer of coatings provides a good interface with the substrate and high bearing capacity, the upper – defines the functional characteristics of the coatings (hardness, wear and oxidation resistance, low coefficient of friction, heat resistance, etc.). Polyphase coatings on Ti–Al–B–N showed the best properties in comparison with more simple systems Ti–N and Ti–Al–N. The purpose of this paper is to study the structure–phase states, tribological properties and thermal stability of the gradient nanocomposite coatings based on the perspective of the system Ti–Al–B–N, formed by magnetron deposition of Ti–N coatings and subsequent processing of high–energy beam of (Al + B) ions for fluence – 2×10^{17} and $6 \times 10^{17} \text{ cm}^{-2}$.

Coatings deposition was carried out on the installation of the ion–magnetron sputtering «QUANT», using DC magnetron gun with Ti target. Coatings thickness of 10 μm was deposited on high strength steel 30HGSN2A samples in the reactive medium of a gas mixture of argon and nitrogen. After deposition of the coatings surface was subjected to ion beam bombardment using a pulsed vacuum arc ion source «DIANA–3». We investigated the result of effect two–component ion beams (Al + B) on the coatings.

The structural–phase state were examined by transmission electron microscopy, high resolution, for foil, representing a cross–section of the sample with a gradient coatings (JEOL JEM–2100F, EM–09 100 Ion Slicer) and X–ray analysis (DRON–7). Concentration profiles of elements on the thickness of the coatings were investigated by mass–spectrometry of secondary ions (MS–7201M) and X-ray spectral microanalysis (JEOL JEM–2100F). Tests of samples on the friction and wear resistance were carried out by tribometer (2070SMT–1) on the pattern «rotating counterface – stationary sample with coatings». Coatings hardness and the elastic modulus of the coatings material was measured nanoindenter «NanoHardnessTester, CSM». Thermal stability was investigated by vacuum annealing of samples with coatings in the temperature range 773–1273 K.

FORMATION OF COMPOSITE COATINGS WITH ADJUSTABLE RATIO OF COMPONENTS.

M.V.Shandrikov¹, A.V.Tyunkov²

¹*Institute of High Current Electronics, Tomsk, Russia,
shandrikov@opee.hcei.tsc.ru*

²*Tomsk State University of Control System and Radioelectronics,
Tomsk, Russia*

The metal-oxide plasma source on the basis of discharge system with electron injection from a constricted arc discharge having sectioned sputtering electrode was designed and used for formation of composite coatings with adjustable ratio of components. Discharge system of such type of the plasma source is multifunctional. It allows to carry out both generation of bulk gaseous plasma (argon, nitrogen, oxygen) and deposition of various metal, and thus to obtain oxidation and complex composite coatings. Gaseous plasma in a vacuum chamber is generated by means of injection of electrons beam from the emitter based on constricted arc discharge (first stage) and additionally accelerated in the cathode layer of non-self-sustained bulk gaseous discharge (second stage). The additional discharge stage with 6 insulated sputtering metal targets (Ti, Zn, Cu, Al) set at the output of the plasma gun. Life time test of designed discharge system under stable operating parameters in an atmosphere of oxygen plasma was more than 500 hours. Our results demonstrate that the proposed approach allows a precision

control of the percentage of materials for Me-Me (Ti-Zn, Ti-Cu) and Me-Me-O (Zn-Al-O) coatings by changing the bias voltage on the sections of the targets. The heterogeneity of proportions of the components in the coating does not exceed $\pm 2\%$. The heterogeneity of the samples with linear dimensions of $30 \times 30 \text{ cm}^2$ does not exceed 15%.

TITANIUM NICKELIDE FORMATION BY COMPRESSION PLASMA FLOWS

**V.I. Shymanski, V.V. Uglov, N.N. Cherenda, V.A. Lushkevich,
V.M. Astashynski¹, A.M. Kuzmitski¹**

*Belarusian State University, Minsk, Belarus, 220030, Nezavisimosty ave., 4
e-mail: shymanskiv@mail.ru, uglov@bsu.by*

¹*B.I. Stepanov's Institute of Physics of National Academy of Science of
Belarus, Minsk, Belarus, 220072, Nezavisimosty ave., 68
e-mail: ast@imaph.bas-net.by*

Biocompatible materials belong to the perspective class of the materials that are usually used in medicine, surgical industry and others. In many cases it is important to use a medical tool only with the surface biocompatibility layer. Therefore the main aim of the work is formation of the surface layer (coating) consisting of biocompatible alloy titanium nickelide (TiNi) by means of compression plasma flows (CPF).

In the experiments a substrate from commercial pure titanium was used. A nickel coating was deposited on the titanium substrate by electrochemical method. The thickness of the coatings was ranged from 1 to 6 micrometers. After this CPF were used for treatment the formed "coating/substrate" system. The main varied parameter at CPF treatment was an absorbed energy density that was changed from 5 to 23 J/cm^2 .

The CPF influence at chosen parameters provides melting of the coating and a part of the substrate. In the melted zone hydrodynamics mixing of the liquid coating and substrate takes place. After crystallization a surface layer with uniform distribution of the nickel is formed.

According to the X-ray diffraction measurements a titanium nickelide cubic phase (B2 structure) was formed. The lattice parameter of this structure

is equal to 0,300 nm. The thickness of the layer contained TiNi phase is about 5 – 7 μm . The formation this phase at the thickness nickel layer 2 – 4 μm occurs at absorbed energy density from 5 to 13 J/cm^2 . At absorbed energy density less than 5 J/cm^2 the temperature of the surface layer is not enough for full melting the coating and the same deep of titanium substrate. If the absorbed energy density is more than 13 J/cm^2 a great part of the nickel is evaporated and its concentration is also not enough for TiNi formation.

The experimental results allowed to find an empirical relation between absorbed energy density and thickness of the nickel coating for to form TiNi phase in the melted layer.

Mechanical measurements showed the Young's module of the surface layer contained TiNi phase is equal 66 ± 6 GPa that is closed to the corresponding value of a biological tissue. In addition the CPF influence provides the hardening of the surface layer and its microhardness is up to 7 GPa.

This research was partly supported by Grant F11M-068 of Belarusian Republic Fund of Fundamental Researches

THE DEPOSITION THIN FILMS OF DIOXIDE TITANIUM BY MEANS OF DUAL MAGNETRON SPUTTERING

D.V. Sidelev, Y.N. Yuryev.

*Tomsk Polytechnic University, Tomsk, Russian Federation,
Dimas167@tpu.ru*

¹ *Department of Hydrogen Energy and Plasma Engineering, Tomsk Polytechnic University, Tomsk, Russian Federation, Yurjev@tpu.ru*

This research work is devoted to the deposition of thin films of titanium dioxide with a dual magnetron sputtering system (DMSS). The properties of titanium oxide films were investigated depending on deposition parameters. The first phase of the experimental work is to study of modes of deposition of DMSS, when the concentration of reactive gas in the total flow and total pressure in the vacuum chamber change.

The second phase of work is to study the optical properties of TiO_2 films and their phase composition depending on the mode of deposition. The investigation of the optical characteristics of thin films was produced using a spectrophotometer SF-2000 and ellipsometer. The results show that the experi-

mental samples with the same thickness have different optical properties. This is explained by the different phase composition of the thin films.

The investigation the phase composition of the films was carried out by Raman spectroscopy. The films have different phase composition depending on the mode of deposition. Increasing the total pressure in the chamber and the increase in the proportion of oxygen in the total gas flow leads to a change in phase composition: the phase changes from anatase to rutile.

INVESTIGATION PROPERTIES OF COPPER COATINGS OBTAINED PLASMODYNAMIC METHOD

A. A. Sivkov, A. S. Saigash, D.Yu. Gerasimov. A. A. Evdokimov

TPU, Tomsk, Russia, SivkovAA@mail.ru

The possibility of synthesis and to obtain the volume of the composite material based on high hard titanium in the form of a rough coating thickness of 0.1 mm, the damage when exposed to a metal substrate vysokoentalpiynoy a titanium jet spark plasma generated by pulsed high-current coaxial magnetoplasma accelerator. The average level of hardness of the material is regulated by changes in pressure nitrogen atmosphere of 0.1 atm. to 1.0 atm.

ON POSSIBILITY OF REGULATING THE HARDNESS OF COATINGS BASED ON TITANIUM NITRIDE, IN THE PROCESS OF DEPOSITING THEM TO METALLIC SUBSTRATES

A. A. Sivkov, A. S. Saigash, D.Yu. Gerasimov. A. A. Evdokimov

TPU, Tomsk, Russia, SivkovAA@mail.ru

The possibility is shown to synthesize and obtain the volume composite very hard material based on the titanium in the form of coating having the thickness of 0.1 mm. The coating has been deposited with the influence on the metallic substrate by a high enthalpy jet of the titanium electro erosive plasma generated by a pulsed high-current coaxial magneto plasma accelerator.

The average level of material hardness is regulated by changing the value of pressure in the nitrogen atmosphere from 0.1 atm. to 1.0 atm.

RESEARCH OF PROPERTIES OF COPPER COATINGS OBTAINED BY THE PLASMODYNAMIC METHOD

A. A. Sivkov, A. S. Saigash, Yu. L. Kolganova, M. E. Nazarova

TPU, Tomsk, Russia, SivkovAA@mail.ru

The paper presents results of research the possibility of using a pulsed coaxial magneto plasma accelerator with copper electrodes, for depositing copper coatings on aluminum contact surfaces. The coated material has been generated by electro erosion way from the surface of the accelerator channel. At atmospheric conditions, the samples have been obtained with a copper coating thickness about 100 microns and a coating diameter of 180 mm. The experimental dependence has been revealed. It allows to determine accelerator's structural and energetic parameters, depending on the necessary mass of material required for the deposition of high-quality coatings. The relation of samples transient resistance with physical and chemical characteristics of coatings has been revealed. The proposed method allows not only to solve the problem of combining the copper-aluminum contact pair, but also to reduce the energy loss due to a substantial reduction of the contact resistances.

FABRICATION OF METAL-SUPPORTED SOLID OXIDE FUEL CELLS

**A. A. Soloviev, N. S. Sochugov, I. V. Ionov, A. I. Kirdyashkin¹,
V. D. Kitler¹, A. S. Maznoy¹, T. I. Sigfusson²**

Tomsk polytechnic university, Tomsk, Russia, andrewsol@mail.ru

¹ *Dept. of Structural Macrokinetics of Tomsk Science Centre, Tomsk, Russia,
maznoy_a@mail.ru*

² *Innovation CenterIceland, Reykjavik, Iceland, this@simnet.is*

The results of the fabrication and research of metal-supported solid oxide fuel cells are presented. Porous Ni-Al plates manufactured by self-propagating high temperature synthesis were used as a metal support of fuel cells. The effect of synthesis conditions and raw materials mixture on the phase composition, microstructure, porosity, gas permeability and other properties of the Ni-Al samples were investigated. Solid oxide fuel cells with the structure of Ni-ZrO₂:Y₂O₃ anode / ZrO₂:Y₂O₃ electrolyte / La_{0.8}Mn_{0.2}SrO₃ cathode were formed on the surface of porous Ni-Al supports by the methods of high-temperature sintering and magnetron sputtering. Power density of the fuel cell on a metallic support reaches 400 mW/cm² at 800°C when humid H₂ was used as fuel and air was used as an oxidant.

MULTILAYER FILM-TYPE STRUCTURES FOR RADIATION PROTECTION OF SEMICONDUCTOR DEVICES

S. S. Grabchikov¹, S. B. Lastovski¹, Yu. V. Bogatyrov¹, P. V. Pankratov¹, A. G. Pyatkevich¹, V. V. Uglov².

¹ *Scientific-Practical Materials Research Centre NAS of Belarus,
Minsk, Belarus, gss@ifftp.bas-net.by*

² *Belarusian State University, Minsk, Belarus, Uglov@bsu.by*

The development of new methods and materials for shielding of electronic elements and units from space radiation is of a particular interest for the last decades. In the spectrum of space radiation main contribution of the absorbed dose is made by electrons and protons.

In the present work we propose a method for the formation of screens for shielding of microelectronics devices from the action of penetrating radiation by electroplating of *Bi* and $Pb_{75}Sn_{25}$ layers on copper bars. Metal layers alternated with copper ones and were deposited with variable thickness and ratios.

Shielding efficiency of silicon bipolar structures K_s was estimated by the concentration of secondary radiation defects induced by electron irradiation performed with the use of protective screens and without them. For MOS-transistor structures shielding efficiency was estimated by changes of drain-gate current-voltage characteristics. Concentration of radiation defects was measured by *Deep Level Transient Spectroscopy (DLTS)*.

Measurements of shielding efficiency were carried out for silicon *n+p*-structures and MOS-transistor structures based on *Bi/Cu* and $Pb_{75}Sn_{25}$ multilayers in the mode of shadow shielding from electron irradiation ($E=4$ MeV). For bipolar structures with *Bi/Cu* screen (2,4 μm thickness) $K_s = 150 \div 160$, maximum K_s value (100 \div 120) is obtained for $Pb_{75}Sn_{25}$ screens with 1,8 μm thickness. In MOS-transistor structures maximum value of $K_s=1000$ is obtained for $Pb_{75}Sn_{25}$ screens with 1,8 μm thickness.

Dependences of K_s on layer thickness (for *Cu* shield) were measured for comparative analysis of the obtained results. It was found that for copper shield with thickness more than 2,3 mm radiation defects are induced out of silicon *n+p*-structures. This fact is in a good accordance with reference data on electron range in copper that equals to 2,1 g/cm^2 for electron energy $E=4$ MeV.

EVOLUTION OF PHASE COMPOSITION AND CRYSTAL STRUCTURE OF TiZrAlN COATINGS AT ITS DEPOSITION AND IRRADIATION

**V.V. Uglov, G. Abadias¹, A. Michel¹, S.V. Zlotski,
I.A. Saladukhin, A.Y. Rovbut**

Belarusian State University, Minsk, Belarus, Uglov@bsu.by

¹*University of Poitiers, Poitiers, France, gregory.abadias@univ-poitiers.fr*

Structure and phase composition of nitride-based coatings are significantly improved by the addition of aluminum. Nanocrystalline structure of the coatings can be obtained by varying the aluminum concentration. This

structure is stable under irradiation mainly due to the extended grain boundaries acting as sinks of native and radiation-induced defects.

Crystalline structure and phase composition of thin (300 nm) films $(\text{Ti,Zr})_{100-x}\text{Al}_x\text{N}$ ($x \leq 36.4$ at.%), formed by magnetron sputtering and irradiated by Xe^{2+} ions with the energy of 180 keV, integrated doses $1 \cdot 10^{16} \text{ cm}^{-2}$ and $5 \cdot 10^{16} \text{ cm}^{-2}$, were studied by the X-ray diffraction.

It is found that the increase of Al concentration results in the transformation of structure from nanocrystalline ($x \leq 9.3$ at.%) to nanocomposite one ($11.6 \leq x \leq 20.6$ at.%), and then to amorphous ($25.1 \leq x \leq 36.4$ at.%). Phase composition of the coatings changes from single phase (solid solution c-(Zr,Ti,Al)N with NaCl-type structure and preferred orientation (111)) to two-phase (c-(Zr,Ti,Al)N with preferred orientation (002) and amorphous phase a-(Al,Ti,N)), and then again to single-phase (amorphous phase a-(Zr,Ti,Al,N)). Nanocomposite coating $(\text{Ti,Zr})_{100-x}\text{Al}_x\text{N}$ is a composite based on solid grains c-(Zr,Ti,Al)N with the size of 2-6 nm surrounded by an amorphous layer of a-(Al,Ti,N). Formation of nanocomposite is due to spinodal segregation of titanium and aluminum to the grain boundary of the solid solution with the growth of grain boundary amorphous phase.

Evolution of structural-phase state of $(\text{Ti,Zr})_{100-x}\text{Al}_x\text{N}$ coatings irradiated by Xe^{2+} ions depends on their original state. Nanocrystalline and amorphous ($x = 36.4$ at.%) structures are stable under irradiation, whereas nanocomposite and amorphous ($x = 25.1$ at.%) transform to nanocrystalline ones. Structural changes affect phase composition of the coatings due to the formation of a single-phase system based on solid solution c-(Zr,Ti,Al)N.

Irradiation of nanocrystalline and nanocomposite ($7.1 \leq x \leq 13.8$ at.%) coatings by Xe^{2+} ions leads to layering of c-(Zr,Ti,Al)N to two solutions with varying concentrations of Al as a result of radiation-induced separation of solid solution. The increase of irradiation dose leads to the rise of the volume fraction of Al-rich solid solution phases at the expense of including of grain boundary Al-rich phase.

Mechanisms of crystallization of amorphous phase and solid solution separation under the irradiation by Xe^{2+} ions due to radiation-induced segregation, the influence of internal stresses caused by postcascade distribution of defects and implantation of impurities are discussed.

THE INFLUENCE OF THE ELECTRICAL PARAMETERS OF MAO-PROCESS ON PROPERTIES OF OBTAINED COATINGS

M.M. Yasyukevich., T.I. Odnostoronceva, P.I. Butyagin

M.M. Yasyukevich, Tomsk, Russia, maria.jasjukevich@manel.ru

T.I. Odnostoronceva, Tomsk, Russia, tatyana.odnostoronceva@manel.ru

P.I. Butyagin., Tomsk, Russia, pavel.butyagin@manel.ru

CJSC MANEL, 634015, Tomsk, st. Tsiolkovsky 19, p. 2

Currently MAO-process in industry is more applied. Therefore the obtaining of coatings with specified properties is actually. One of the factors that influences on properties of obtained coatings is the electrical parameters MAO - process.

The influence of the electric parameters of MAO-process, impulse frequency (27-50 Hz), current impulse duration (260-700 μ s) and voltage (450 to 600 V) was carried out.

We have researched influence of the parameters on porosity, roughness and thickness of the MAO-coatings. When duration and impulse frequency increase coating porosity decreases from 11, 9% down to 6, 58% while its thickness and surface roughness increase. Increase of voltage given on a bath leads to growth of a thickness of coatings so far. It's influence on porosity and surface roughness is rather weak. With increasing of the MAO coatings thickness it's porosity decreases but it becomes more rough.

So, changes of the electrical parameters allow to obtain the coatings with different surface roughness and porosity. When the coating thickness is controlled of we can obtain these of different appointment.

DEPOSITION OF DLC FILMS FROM THE MAGNETRON DISCHARGE PLASMA

**Yury Yuryev¹, Alena Yuryeva², Dmitry Korzhenko³
and Olga Stepanova⁴**

¹*Tomsk Polytechnic University, Tomsk, Russia, yurjev@tpu.ru*

²*Tomsk Polytechnic University, Tomsk, Russia, alench@tpu.ru*

³*Tomsk Polytechnic University, Tomsk, Russia, dman@tpu.ru*

⁴*Tomsk Polytechnic University, Tomsk, Russia, omsa@tpu.ru*

This paper is concerned with the problem of the obtaining of the diamond-like carbon (DLC) films. DLC films have high hardness, low friction coefficient, low electrical conductivity, chemical inertness, high thermal conductivity and other excellent properties. Due to these properties DLC films are used as protective, dielectric, antireflecting, antifriction and biocompatible coatings.

The most popular methods for obtaining of the DLC films are vacuum arc evaporation and pulsed laser ablation. However using of these methods presents some difficulties. The main disadvantage of the coatings' deposition from the arc discharge plasma is drop fraction which degrades the quality of the obtained coatings. The disadvantage of the pulsed laser ablation is its technical complexity and difficulties in realization.

In this paper the magnetron sputtering is treated as an alternative method for obtaining of the DLC films. The object of research is dual magnetron sputtering system (DMSS), which has advantages over planar magnetron system. The research of different operation modes of the DMSS while sputtering the carbon target in the Ar environment and the analysis of the hardness, electrical resistance and phase structure of the obtained DLC films on polished stainless steel are reported.

A NEW METHOD FOR THE METALLIZATION OF CERAMIC SUBSTRATES FOR THE NEEDS OF POWER ELECTRONICS

A. Yuryeva¹, V. Krivobokov²

¹*Tomsk Polytechnic University, Tomsk, Russia, alench@tpu.ru*

²*Tomsk Polytechnic University, Tomsk, Russia, krivobokov@tpu.ru*

The metallization of the ceramic substrates is one of the critical procedures in the power semiconductor units' production.

Direct Bonded Copper (DBC) technology is widely used for creation of the metallic layer on ceramics. Thick high-quality metallic layers can be produced by the means of this technology. However, DBC technique exposes substrates to the high temperature which degrades its' functional qualities.

Magnetron sputtering of the liquid metal target is considered in this article as a technique for the copper coatings' production on the ceramic substrate. At this moment in time a lot of data about physical principles of magnetron sputtering systems' (MSS) operation and its operating modes is accumulated and analyzed. Preliminary cleaning of the substrates by the low-energy ion beam is used for increase in coating's adhesion.

Magnetron sputtering system with heat-insulated target proves itself to be a good instrument for the obtaining of the thick (from ten to hundred microns) metallic coatings with high deposition's rates (from tens nanometers per second). In case of sputtering from the liquid metal target the transition to the self-sputtering operating mode is possible. This mode provides cleaner coatings and enhances its' functional characteristics (diminishes roughness and electrical resistivity, increases density without impurities) than usual mode. Another advantage of the MSS with heat-insulated target is absence of high temperatures, dangerous and flammable gases, radiation and chemically aggressive contaminants during the process of deposition.

OPTICAL STUDIES OF AMORPHOUS SILICON FILMS**E. A. Baranov, A. O. Zamchiy, S. Ya. Khmel***Institute of Thermophysics SB RAS, Novosibirsk, Russia,
zamchiy@gmail.com*

Thin films of amorphous hydrogenated silicon (a - Si: H) are widely used in solar cells, thin film transistor, liquid crystal displays, etc. [1]. One of the promising techniques for synthesizing silicon thin films is the Gas-Jet Electron Beam Plasma Chemical Vapor Deposition, GJ-EBP-CVD method. This method provides a high rate of silicon growth for solar cell (SC) with low energy consumption in a standard vacuum chamber [2].

Based on the measured spectral transmittance of silicon films by envelope method [3] and PUMA [4] we have found the spectral dependence of the refractive index and absorption coefficient of the films, as well as their dependence on substrate temperature and silane dilution with hydrogen. The obtained data are in good agreement with literature sources.

The optical band gap was determined from the spectral dependence of the absorption coefficient of the films by high-energy part of the curve Tauc [5]. The value of optical band gap decreases with increasing substrate temperature, which is associated with a decrease of the concentration of hydrogen in the film. The optical band gap of the films grown in a series of experiments on the hydrogen dilution increases probably due to the increasing concentration of hydrogen in them, or with an increase in the degree of ordering of the material at high dilution.

1. S. D. Brotherton, – “Polycrystalline silicon thin film transistors“, *Semicond. Sci. Technol.* V. 10, P. 721-738, 1995.

2. R.G. Sharafutdinov, S.Ya. Khmel, V.G. Shchukin, – “Gas-jet electron beam plasma chemical vapor deposition method for solar cell application” *Solar Energy Materials & Solar Cells* V. 89 P. 99 -11, 2005.

3. R. Swanepoel, – “Determination of the thickness and optical constants of amorphous silicon”, *J. Phys. E: Sci. Instrum.* V. 16, 1983.

4. E. G. Birgin, I. Chambouleyron, and J. M. Martínez, – “Estimation of optical constants of thin films using unconstrained optimization”, *Journal of Computational Physics* V. 151, P. 862 - 880, 1999.

5. Tauc, – “The optical properties of solids”, Ed. F. Abeles, North. Holland, Amsterdam, P. 277, 1970.

**PROPERTIES OF THE ZIRCONIUM ALLOY SURFACE
MODIFIED BY PULSED ELECTRON AND ION BEAMS**

**I.P. Chernov¹, E.V. Beresneeva¹, S.V. Ivanova³, N.N. Koval²,
A.M. Lider¹, N.S. Pushlina¹, G.E. Remnev¹**

¹*National Research Tomsk Polytechnic University, 634050 Tomsk, Russia,
chernov@tpu.ru*

²*Institute of High Current Electronics SB RAS, 634055 Tomsk, Russia*

³*National Research Nuclear University «MPhI», 115409 Moscow, Russia*

Zirconium alloys are important constructional materials of nuclear reactors. They have a low thermal neutron capture cross section, high corrosion resistance and strength characteristics. However, these alloys are hydride-forming, the penetration of hydrogen into the bulk material leads to a decrease of plasticity, formation of cracks and, as a consequence, the subsequent destruction. Therefore, the protection against the penetration of hydrogen in zirconium alloys is an important problem.

The report discusses the results of studying the surface properties of zirconium alloys Zr1% Nb subjected to the effect of a pulsed electron beam PEB (electron energy $E = 18$ keV, pulse $\tau = 50$ ms, the energy density of $15 - 20$ J/cm²) and pulsed ion beam PIB (carbon ion energy 200 keV, pulse $\tau = 80$ ns, energy density of 1.5 J/cm²). In the process of irradiation by PEB and PIB a 10-micron-thick surface layer is formed with a modified structure-phase state. A characteristic feature of the structure of the alloy under the influence of PEB is the presence of the martensite twinning of the plate in the surface layer, the dimensions of which are $0.1 - 0.3$ microns. The modified surface layers possess higher hardness (40%) and durability (30%) compared with the original zirconium alloy. It is very important that they are an effective barrier against the penetration of hydrogen into the bulk material. The penetration of hydrogen in the zirconium alloy bulk is $2 - 3.0$ times lower when exposed to PEB and $4 - 5$ times when influenced by PIB. In addition, the degradation of mechanical properties of alloys modified by pulsed beams under the influence of hydrogen is much slower than that of the original alloy.

SORPTION CAPACITY INVESTIGATION OF CARBON NANOSTRUCTURE MATERIALS

L.V. Gulidova

*Department of General Physics, Institute of Physics and Technology,
National Research Tomsk Polytechnic University, Tomsk, Russia
l_gulidova@sibmail.com*

As a result of energy resources depletion and problems of environmental pollution, hydrogen has been recognized as an ideal fuel. As high-performance and ecological energy carrier it has big perspectives for general using in power engineering, particularly as a fuel for transports. One of the general problems is the lack of effective methods of storage and transportation of hydrogen. Recently carbon materials, in particular, carbon nanotubes, have been regarded as reservoirs for hydrogen storage.

The carbon material was produced by conversion of natural gas. The carbon material has different modifications of carbon as nanotubes, nanofibers, onion-particles, microcrystals of graphite and amorphous carbon. The content of nanotubes in the final product is not more than 70%. The received material was chemically treated against impurities (other modifications of carbon) and metallic catalysts. The samples of carbon material were researched with the help of scanning and transmission electron microscopy. The using of microscopes allows detecting different nanotubes with diameters from 50 to 150 nm.

The Advanced Materials Corporation's Gas Reaction Controller automated complex was used for measuring the sorption of hydrogen by carbon materials. The theory of operation of the complex is based on the measuring and comparing the amount of gas before and after reaction. The samples were used in compressed state. The carbon materials were hydrogen saturated with the temperature 243K and 300 K and the pressure of the hydrogen 0-8atm. High purity hydrogen (99,9999%) was used for the investigation of the sorption capacity of carbon material. The hydrogen was produced by the HyGen-200 generator. It allows evading anomalously high sorption capacity and problems of results reproducibility.

Hydrogen concentration at room temperature is more than five times less than at low temperature. The maximum hydrogen sorption capacity of carbon materials is 4 wt% more at high pressure and low temperature. The time of each cycle can be shortened, because the amount of adsorbed hydrogen does not change with increasing sorption time. All these results prove the

high efficiency of using the carbon material produced by conversion of natural gas as a hydrogen sorbent.

**STRUCTURAL REGULARITIES OF FORMATION OF GRADIENTE
SURFACE LAYERS ON BASE OF INTERMETALLIC
NANODIMENSIONAL PHASES AT ION IMPLANTATION**

I.A. Kurzina¹, Yu.P. Sharkeev², E.V. Kozlov³

Tomsk State University, Tomsk, Russia, kurzina99@mail.ru

¹*Tomsk Polytechnic University, Tomsk, Russia*

²*Institute of Strength Physics and Materials Science of RAS, Tomsk, Russia,
sharkeev@ispms.tsc.ru*

³*Tomsk State University of Architecture & Building, Tomsk, Russia,
kozlov@tsuab.ru*

The surface layers of metals consisting of intermetallides with nanodimensional grain parameters can intensely protect a bulk material. The formation of intermetallic structures in surface layers of metals can be successfully realized by irradiation of the surface with high intensity beams. The problems associated with the physical and chemical mechanisms of formation of gradient surface structures under conditions of high intensity ion implantation have remained obscure up to now. The aim of this work is to explore structural phase state evolution, the parameters of the dislocation substructure, and the grain substructure of titanium in dependence on irradiated parameters and the structural state of the target after aluminum ion implantation.

The structural-phase states (average grain size, 0.3, 1.5, 17 and 38 μm) of titanium targets were studied after implantation with aluminum ions at a dose of $2.2 \cdot 10^{17}$ – $1.0 \cdot 10^{19}$ ion/cm² using the Mevva-V.RU and Raduga-5 sources. It is found by the simulation that, in samples with relatively fine grains, a significant contribution to the formation of the depth profiles of implanted atoms comes from radiation-enhanced diffusion (including the grainboundary one); in polycrystalline samples, from diffusion along migrating extended defects, which appear and rearrange themselves in the process of ion implantation. It was established the structural feature of the implanted titanium layers. The size, shape and localization of the formed phases (TiO_2 , Ti_2O , TiC , Ti_3Al , TiAl , Al_3Ti) depend strongly on the grain size of titanium

target. TiO₂ nanograins precipitate at dislocations if the matrix grain size is 0.3 or 1.5 microns. Ti₂O is observed in the form of a film on the surface in the case of mesopolycrystalline titanium (17 μm). All titanium samples with different grain sizes are characterized by the formation of an intermetallic Ti₃Al phase. This phase is observed to localize mainly along the grain boundaries of α-Ti for titanium with cybmicro- and microcrystalline states. With an increase in the grain size, we detected increased thickness of the Ti₃Al layers. In polycrystalline titanium after implantation by Al-ions the secondary phases (Ti₃Al, TiAl, TiO₂, TiC) formed in the body of grains of titanium matrix. Formation of the TiAl₃-phase was observed only for titanium with grains size 0,5 and 1,5 μm. For polycrystalline titanium it was observed the formation of the intermetallic phases Ti₃Al, TiAl and the surface layer with gradients structure and phase composition. The modification of the structural state and phase composition of titanium surface layer leads to significantly increasing of the mechanical properties due to disperse and grain boundary strengthening.

STRUCTURAL STATE AND PHASE COMPOSITION OF THE FINE-GRAINED TITANIUM IMPLANTED BY ALUMINIUM IONS

**I.A. Kurzina¹, N.A. Popova², E.L. Nikonenko², M.P. Kalashnikov³,
K.P. Savkin⁴, G.Yu. Yushkov⁴, E.M. Oks⁴, Yu. P. Sharkeev³**

Tomsk State University, Tomsk, Russia, kurzina99@mail.ru

¹*Tomsk Polytechnic University, Tomsk, Russia*

²*Tomsk State University of Architecture & Building, Tomsk, Russia,
vilatomsk@tsuab.ru*

³*Institute of Strength Physics and Materials Science of RAS, Tomsk, Russia,
sharkeev@ispms.tsc.ru*

⁴*Institute of High Current Electronics, Siberian Branch, Russian Academy
of Sciences,
Tomsk, Russia, savkin@opee.hcei.tsc.ru*

Modification of metals and alloys in nano- and subnanostructured state by ion beams are currently of great interest. Ion implantation can not only stabilize/recrystallize a submicrostructure presented in a metal target, it can also synthesize nanocrystalline phases in the surface layers of irradiated ma-

terials. The aim of this work is to explore structural phase state evolution, the parameters of the dislocation substructure, and the grain substructure of fine-grained titanium in dependence on the structural state and dose of irradiation of the target after aluminum ion implantation.

The structural-phase states (average grain size, 0.2 -2 μm) of titanium targets were studied after implantation with aluminum ions at a dose of $10^{17} \div 10^{18}$ ions cm^{-2} using the Mevva-V.RU source. It was observed the change of the grain structure of the titanium after ion implantation. Implantation leads to a refinement of the grain material and a change in the coefficient of anisotropy. Presence of a gradient of temperature in the implanted layer close to a surface (on depth to 200 nanometers from the irradiated surface) leads to additional crystallization of a material. It was established that share of fine grains increased to 30 % after ion implantation.

In a titanium target (mean size 1.5 mm) it is allocated two types of α -Ti grains, differing on phase composition, defective structure and the sizes. It was established the present of the fine grains in the range from 0,1 \div 0,5 μm and large grains in an interval 0,5 \div 5 μm . The ion implantation of aluminum ions in titanium ensures the creation of nano-sized intermetallic phases and oxides in the surface layers. TiO_2 nanograins precipitate at dislocations if the matrix grain size. All implanted titanium targets with different dose of irradiation are characterized by the formation of an intermetallic Ti_3Al phase. This phase is observed to localize mainly along the grain boundaries of α -Ti. With an increase in the grain size, we detected increased thickness of the Ti_3Al layers. Particles of phase TiAl_3 are formed with a smaller volume fraction in comparison with phase Ti_3Al and localized on borders of grains of a titanium. It is established that as a result of an ion implantation the defective structure of a material changes essentially. There is a substantial growth of density of dislocations and stress fields in fine grains concerning an initial condition of the titanium with increasing of irradiation dose.

THE MORPHOLOGY, PHYSICO-MECHANICAL AND ELECTRO-CHEMICAL PROPERTIES OF MICRO-ARC CALCIUM-PHOSPHATE COATINGS ON NANOSTRUCTURED TITANIUM SURFACE

E.V. Legostaeva¹, Yu.P. Sharkeev¹, S.V. Gnedenkov², E.G. Komarova¹, V.S. Egorkin², S.L. Sinebryukhov², G.V. Lyamina³, I.A. Khlusov,⁴

¹ *Institute of Strength Physics and Materials Science of Siberian Branch Russian Academy of Sciences, Tomsk, Russia, lego@ispms.tsc.ru, sharkeev@ispms.tsc.ru, katerina@ispms.tsc.ru*

² *Institute of Chemistry of Far Eastern Branch Russian Academy of Sciences, Vladivostok, Russia, svg21@hotmail.com, egorkin@ich.dvo.ru, sls@ich.dvo.ru*

³ *National Research Tomsk Polytechnic University, Tomsk, Russia, ggv_1@rambler.ru*

⁴ *Scientific Educational Center «Biocompatible Materials and Bioengineering» at Tomsk Polytechnic University and Siberian State Medical University, Russia, khl@ultranet.tomsk.ru*

Abstract The morphology as well as physical and mechanical properties of the micro-arc calcium-phosphate coatings (roughness, porosity, thickness, adhesion strength, phase and elemental compositions) deposited in electrolyte based on the aqueous solution of orthophosphoric acid, hydroxyapatite and calcium carbonate have been studied. The electrochemical behavior of nanostructured titanium without and with calcium-phosphate coatings in different mediums (3% sodium chloride solution, Ringer-Locke's solution, mix of 10% water solution of fluoric and sulfuric acids) was investigated using potentiodynamic polarization, electrochemical impedance spectroscopy techniques and analysis of the etching curves. It was found that in the Ringer-Locke's solution at 37°C the calcium-phosphate coating on the nanostructured titanium surface considerably reduces the current density in the active dissolution region and passive region of the potentials. It can protect the nanostructured titanium from corrosion in mix of 10% water solution of fluoric and sulfuric acids in the temperature interval from 20 to 40°C ($E_A = 47 \pm 8$ kJ/mol). As the temperature increases up to 75°C the calcium-phosphate coating starts to corrode.

PET TRACK ETCH MEMBRANES IN ELECTROLESS TEMPLATE-ASSISTED SYNTHESIS OF SILVER NANOSTRUCTURES

A.A.Mashentseva, M.V.Zdorovets, A.V.Russakova,
B.N.Aubakirov, D.B.Borgekov

Astana Branch of the Institute of Nuclear Physics, National Nuclear Center of Kazakhstan, Astana, Kazakhstan, mashentseva.a@gmail.com

Template synthesis (TS) is an elegant chemical approach for the fabrication of nanostructures. A variety of nanowire arrays have been obtained by filling a porous template that contains a large number of holes with controlled shape and size as well as a narrow size distribution. The use of track-etched membranes as template material for the bottom-up synthesis of ordered nanostructures is one of the most topical and challenging issues in modern materials science. Two main techniques are used for this approach: electroless and electrochemical deposition (Fig.1).

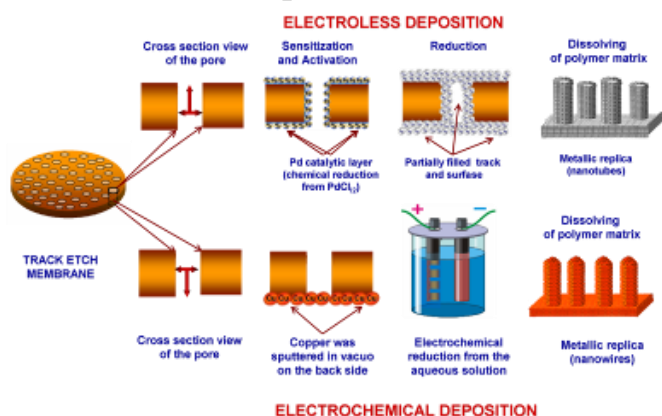

Fig.1. Principles of the most used techniques in TS

PET membranes were irradiated by Kr¹⁵⁺ ion of 1,75 MeV on the DC-60 accelerator of the Astana branch of the INP NNC (a nominal thickness of 12 μm and a pore density of 10⁶ pores/cm²). The one side of the PET film was treated with 9M sodium hydroxide: this etching feature provides an asymmetric conical pores, breakdown time was detected with phenolphthalein as indicator.

The TEMs was pre-activated and activated at room temperature and dipped in freshly prepared silver-plating solution. The electroless plating was done for different time at room temperature. After the deposition was over, the membrane was thoroughly rinsed with deionized water and ethanol and dissolved in NaOH for further analysis.

A NT-206[®] atomic force microscope was used to visualize the topography of the membranes surface before deposition of silver and after removing

polymer template (Fig.2). Surface topography of all samples was characterized using Scanning Electron Microscope Jeol JSM-750F.

Higher magnification SEM of the samples showed that the silver needles were synthesized successfully, with average base diameter of (340 ± 55.45) nm.

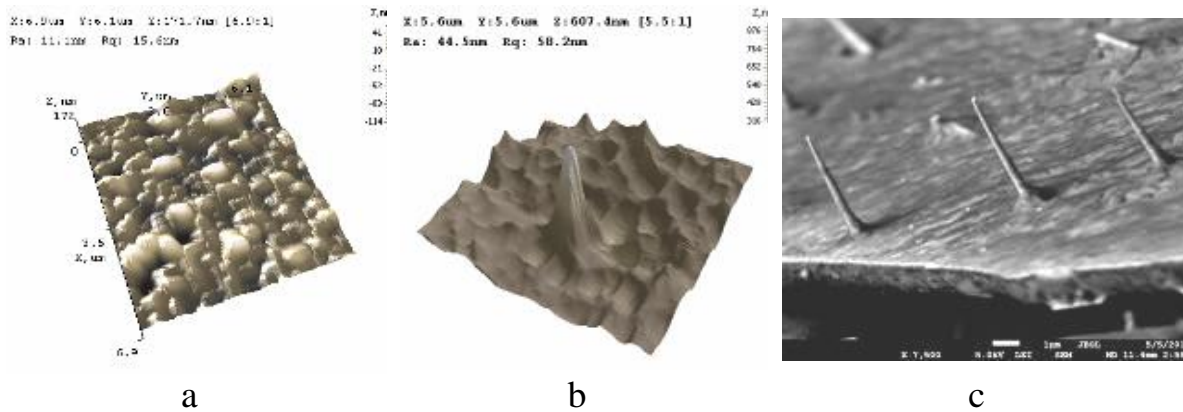

Fig.2 - AFM topography of PET: a) front (b) back- side (c) SEM images of silver replica

THE PLASMADYNAMIC SYNTHESIS OF SILICON CARBIDE

D. S. Nikitin, A. A. Sivkov¹, A. Ja. Pak²

Tomsk Polytechnic University, Tomsk, Russia, dima_n@sibmail.com

¹ *Tomsk Polytechnic University, Tomsk, Russia, sivkovAA@mail.ru*

² *Tomsk Polytechnic University, Tomsk, Russia, alexpk@sibmail.com*

Silicon carbide was synthesized in 1893 by the American engineer Edward Acheson. Since then the study of properties and synthesis of silicon carbide is a pressing problem. It is well known that SiC has such characteristics as superhardness, stability to high temperatures and reliable corrosion resistance. In the middle of the XX century it was found unique semiconducting properties of SiC: a wide band gap (~ 3 eV), a high strength of electric breakdown, emission of light in the entire visible range. It is possible to improve electrophysical characteristics by the use of nanostructured materials.

This article explores the fundamental possibility of synthesis silicon carbide in an electric hypervelocity plasma jet. Plasma flow is generated of by a coaxial magnetoplasma accelerator with graphite electrodes.

The synthesized product was analyzed by modern techniques: X-ray diffraction, transmission electron microscopy.

On the basis of test results it was proved the dominant content of nano-SiC in the product. In addition, we investigate the structural and phase characteristics of the synthesized ultrafine powder.

SYNTHESIS OF SUPERHARD NANOSTRUCTURED COATINGS Ti-Hf-Si-N AND ANALYSIS OF THEIR PROPERTIES

**A.D. Pogrebnyak¹, B.R. Zhollybekov², V.M. Beresnev³, F.F. Komarov⁴,
P. Konarski⁶, V.V. Uglov⁴, M.V. Kaverin¹, D.A. Kolesnikov⁵, N.A.
Makhmudov⁷, V.V. Grudnitskii³, S.V. Plotnikov⁸**

¹*Sumy State University, Sumy Institute for Surface Modificatrion,
St.R-Korsakov 2, 40007 Sumy, Ukraine, e-mail: alex@i.ua*

²*Karakalpak State University, Nukus, Uzbekistan.*

³*Kharkov National University, Kharkov, Ukraine*

⁴*Belarus State University, Minsk, Belarus*

⁵*Belgorod State University, Belgorod, Russia*

⁶*Tele-Radio Research Institute, Warszawa, Poland*

⁷*Samarkand Branch of Tashkent University of Information, Samarkand,
Uzbekistan*

⁸*East-Kazakhstan State Techical University, Ust-Kamenogorsk, Kazakhstan.*

New Superhard coatings based on Ti-Hf-Si-N featuring high physical and mechanical properties were fabricated. We employed a vacuum-arc source with HF stimulation and a cathode sintered from Ti-Hf-Si. Nitrides were fabricated using atomic nitrogen (N) or a mixture of Ar/N, which were leaked-in a chamber at various pressures and applied to a substrate potentials. RBS, SIMS, GT-MS, SEM with EDXS, XRD, and nanoindentation were employed as analyzing methods of chemical and phase composition of thin films. We also tested tribological and corrosion properties. The resulting coating was a two-phase, nanostructured nc-(Ti, Hf)N and α -Si₃N₄. Sizes of substitution solid solution nanograins changed from 3.8 to 6.5 nm, and an interface thickness surrounding α -

Si₃N₄ varied from 1.2 to 1.8 nm. Coatings hardness, which was measured by nanoindentation was from 42.7 GPa to 48.6 GPa, and an elastic modulus was $E = (450 \text{ to } 515) \text{ GPa}$. There is also presented cross-section of coating.

The films stoichiometry was defined for various deposition conditions. It was found that in samples with superhard coatings of 42.7 to 48.6 GPa hardness and lower roughness in comparison with other series of samples, friction coefficient was equal to 0.2, and its value did not change over all depth (thickness) of coatings. A film adhesion to a substrate was essentially high and reached 25 MPa.

PLASMODYNAMIC SYNTHESIS of B-C-N SYSTEM CRYSTALLINE PHASES IN HYPERHIGH SPEED ELECTRODISCHARGED PLASMA JET

I.A. Rakhmatullin, A.A. Sivkov, A.Ya. Pak, I.I. Shanenkov

Tomsk Polytechnic University, Tomsk, Russia, rahmatullin_i@bk.ru

Plasmodynamic synthesis of B-C-N system crystalline phases was carried out using coaxial magnetoplasma accelerator (CMPA) invented in Tomsk Polytechnic University by A.A. Sivkov. CMPA generate hyperhigh speed electrodischarged plasma jet flowing into chamber-reactor filled by required atmosphere. The synthesis characterized by high currents (up to 100 kA) and short times (about 500 μs). Amorphous boron, carbon black and gaseous nitrogen used as initial precursors. Before the synthesis pure boron or mixture of it and carbon black lay in the electric discharge forming zone.

Synthesized product researched using X-Ray diffractometry and transmitting electron microscopy. Data obtained by XRD show that cubic boron nitride or boron carbide or mixture of them could be synthesized using CMPA. Product is nanodispersed and has coherent scattering area values 46 nm for cubic boron nitride and 48 nm for boron carbide. The amount of cubic boron nitride is close to 70 % in the product and 96 % for boron carbide.

**NANODIMENSIONAL INTERNAL STRUCTURE FORMATION
IN METALS UNDER THE ACTION OF PULSED ELECTRIC-
EXPLOSION-INDUCED PLASMA JETS**

V.D. Sarychev, A.U. Granovskiy, V.E. Gromov

Siberian State Industrial University, Novokuznetsk, Russia
sarychev_vd@physics.sibsiu.ru

In this paper the mathematical model of the formation of internal nanocrystalline layers under the influence of the plasma electric explosion of conductors on the hardened surface of metals and alloys. Electroexplosive doping - a way of strengthening metals and alloys with the use of concentrated energy flows. Its essence consists in the formation of a pulsed plasma jet multiphase products of electric explosion of conductors and the impact it has on the surface. When EVL such jets are for heating the surface above the melting point, and for the saturation of the products of the explosion. During the processing of 100 ms is melting the surface layers of depth to 20-30 m and the saturation of the products of the explosion. In this paper we propose a model for the formation nanocrystalline layer, based on the occurrence of Kelvin-Helmholtz instability at the interface zone of doping and the base. This model is based on a linear analysis of plane parallel flows of an incompressible flow of two fluids. For simplicity, we assumed that the melt is a viscous fluid with a density ρ_1 , the kinematic viscosity. Impinging plasma is a perfect fluid density ρ_2 and velocity of sliding. At the interface is assumed that the shear stress components for a viscous fluid is zero. The difference between the normal stress of viscous and ideal fluids has a jump associated with the surface tension. We present the dispersion equation that takes into account all the parameters of the problem. Analysis of this equation leads to the condition of instability. In the numerical analysis were constructed plots of the increment of the wavelength by varying the speed and thickness of the moving layer. At a small thickness of the layer there are two maximum growth rate in nano- and micro-wave range. This fact allows us to conclude about the origin of two-mode Kelvin - Helmholtz on the boundary of the melt and the base.

PRODUCTION OF PHOTON CRYSTAL STRUCTURES: SILICON DIOXIDE - SILVER BY ION BEAM SPUTTERING OF SILVER

**A.A.Semenova¹, E.A.Goodilin^{1,2}, A.P.Semenov, I.A.Semenova,
V.K.Ivanov³, Yu.D.Tretyakov^{1,2}**

*Institute of Physical Materials Science SB RAS, Ulan-Ude, Russia,
e-mail: semenov@ipms.bscnet.ru*

¹*Faculty of Materials Science, Moscow State University, Moscow, Russia,
e-mail: annette_semenova@mail.ru*

²*Faculty of Chemistry, Moscow State University, Moscow, Russia,
e-mail: goodilin@fm.msu.ru*

³*Kurnakov Institute of General and Inorganic Chemistry, Russian Academy
of Sciences, Moscow, Russia, e-mail: info@igic.ras.ru*

In recent years actively developing direction associated with the development of new approaches to obtain nanostructured films and substrates with the effect of the plasmon resonance. Moreover, the phenomenon of plasmon resonance is more practical applications, in particular, provides information about the structure of molecules, including in the composition of living systems in vivo method (Raman scattering) of surface-enhanced Raman spectroscopy (surface enhanced Raman spectroscopy, SERS) having high sensitivity.

To create such substrates often use composite particles based on silica microspheres or polystyrene and nanoparticles of noble metals, the main methods of production, which include chemical methods of deposition of nanoparticles on the substrate surface, the formation of films on the Langmuir-Blodgett method, instilling a separately derived nanoparticles modified amino or thiol groups of the surface of the microspheres, physical methods of deposition of nanoparticles on the substrate.

When using the latter group of methods, including ion sputtering, thermal evaporation and electron beam evaporation in a vacuum, can play an important role those experimental parameters that determine the morphology of the deposited films, predetermined by the peculiarities of the effect of plasmon resonance, from which, in turn, to a large extent further depends on the practical use of these nanomaterials.

Look promising physical processes in a high vacuum sputtering of solid targets by accelerated ion beams.

The deposition on silica microspheres were synthesized by the method of Stöber, of nanoparticles (clusters) of silver by physical sputtering of the

silver target by beam of accelerated argon ions was first shown in the present work.

The study of the relationship of the optical properties of nanostructured substrates with the effect of the plasmon resonance and morphology of the aggregate structures of silver nanoparticles on the photon crystal structure obtained self-assembly of silica microspheres.

A slight variation in the prehistory of the preparation of nanostructured substrates substantially changes their optical properties, due mainly to the characteristics (natural evolution) of the aggregate structure of the deposited on the surface of silica microspheres of ordered clusters and nanoparticles of silver [1].

Substrates of this type could potentially serve as elements of the so-called lab-on-chip, which should allow the study of living cells in the intact condition, and therefore can be used directly for diagnosis of diseases in medicine or for examination in criminology.

[1]. Semenova A.A., Gudilin E.A., Semenova I.A., Semenov A.P., Ivanov V.K., Tretyakov Yu.D. // Doklady Akademii Nauk. 2011. Vol. 438. N.4. C.490-493.

IMPROVEMENT of FATIGUE LIFE of NANOSTRUCTURED TITANIUM with ION IMPLANTATION and ELECTRON BEAM TREATMENT

**Yu. P. Sharkeev, V.A. Kukareko¹, A.V. Byeli²,
N.N. Koval³, Yu.F.Ivanov³, A.Yu. Eroshenko**

ISPMS of SB RAS, Tomsk, Russia, sharkeev@ispms.tsc.ru

¹ *JIME of NANB, Minsk, Belarus, v_kukareko@mail.ru,*

² *PHTI of NANB, Minsk, Russia, vmo@tut.by*

³ *HCEI of SB RAS, Tomsk, Russia, koval@opee.hcei.tsc.ru*

Nanostructured and ultrafine grained state in metals and alloys, obtained with methods of severe plastic deformation, provides the high mechanical properties as yield strength, tensile strength, hardness and microhardness with satisfactory plasticity. For commercially pure titanium nanostructured state provides the mechanical properties compared with the medium strength titanium alloys. The absence of alloying elements and the high mechanical

properties of nanostructured titanium determine its successful application as a material for medical implants. In this case the fatigue life of the nanostructured state titanium has to reach $10^6 - 10^7$ cycles or more. To improve the fatigue life and endurance the various methods of surface treatment have been successfully used, including ion implantation and electron beam treatment.

The paper presents the results of a comparative investigation of the fatigue life and endurance of nanostructured and coarse grained titanium VT1-0. To improve these characteristics the high intensity ion implantation of nitrogen and electron-beam treatment were used. The treatments have been chosen so that the temperature did not exceed the titanium thermostability limit for nanostructured state.

It was shown that both methods, by modifying the surface layers, lead to significant improvement in the fatigue lifewithout reducing the endurance. The results are analyzed in terms of improving the physical nature of the fatigue life of the nanostructured titanium.

CARBON NANOCLUSTERS FORMATION INTO THE SILICON AFTER HIGH INTENSE PULSED ION BEAMS INFLUENCE IN NITROGEN ATMOSPHERE

**G.E. Remnev, S.K. Pavlov, V.I. Shymanski,
V.V. Uglov, M.P. Samtsov**

BelarusianStateUniversity, Minsk, Belarus, 220030, Nezavisimosty ave., 4

e-mail: shymanskiv@mail.ru, uglov@bsu.by

High-Voltage Research Institute at of NationalTomskPolytechnicUniversity,

e-mail: remnev@hvd.tpu.ru, 2a Lenin Ave., Tomsk, 634028, Russia

The present methods of carbon materials synthesis allow to form of the different carbon allotropic modifications defined by the parameters of the influence. One of such methods is an implantation of carbon ions realized in the pulsed regime. The non-equilibrium processes accompanied the pulsed ion implantation at high intensities provide the formation of the carbon-contained nanocrystals. The most promising form that can be synthesized is a nanodiamond with average dimension about some nanometers. The formation of such particles can be used as special ones for the following epitaxial growth of the diamond films.

The experiments on the nanodiamonds formation were fulfilled in the TEMP-4 accelerator with ion energies 250 – 300 keV. A single crystal of silicon was used as a target that was connected with the likeness of its crystal lattice with a diamond one. Two series of experiments were made. In the first one the main changing parameter was the ion current density that was varied from 20 to 100 A/cm². Different values of the ion current density will be promoted to realize the different mechanisms of implantation: with melting of the surface layer at the high ones and without melting at the low ones. Another parameter that is influenced both on the carbon concentration and mechanical damages connected with pulse pressure is pulses number that was varied from 10 to 500.

The Raman spectroscopy results showed that rising of pulse number up to 500 results in increase of the amorphous carbon amount. After the comparison these data with the EPR ones it was concluded that the main reason of the implanted layer amorphization connected with the hydrogen ions content in the beam. According to its spectral analysis the amount of hydrogen is about 20 %. Thereby the structure of the implanted layer depends on the composition of the ion beam.

Therefore a set of new experiments on the high intense pulsed ion implantation in the nitrogen atmosphere were carried out. The nitrogen atoms and ion will be connected with the hydrogen ions forming the stable structures. It will results in decrease the hydrogen in the matrix that will provide the conditions of the nanodiamonds formation without amorphization of the surface layer.

The work was supported by Grant of Belarusian republic fund of foundation research F12MV-005

**COMPACTION OF POWDERS OF TITANIUM NITRIDE
NANOPOWDER SYNTHESIS PLASMODYNAMIC BY
SPARK PLASMA SINTERING**

A. A. Sivkov, D. Yu. Gerasimov, A. A. Evdokimov, A. I. Usikov

Tomsk Polytechnic University, Tomsk, Russia, sivkovaa@mail.ru

SPS is a modified method of hot pressing. Its distinguishing feature is that the pulsed electric current flowing directly through the graphite mold and the workpiece compression of the powder material is positioned between the punches. The latter is applied static force from the hydraulic system. With a combined effect of the plasma spark microdischarges occurring in the gaps between powder particles, quickly and efficiently heats the surface of the particles to the melting point. Static compression ensures convergence and consolidation of the particles. Rapid heating and low cycle times can suppress the grain growth and obtain the equilibrium submicron and even nanostructure material.

Studies of physical and mechanical properties of the obtained bulk samples were performed using computerized systems Nanohardness tester, Microscratch tester and Micromeritics 3D station (CSEM instrument). In the study conducted by nanohardness indentation of four series of different radii of the polished surfaces of all samples. The measurements were performed at the maximum load on the indenter Vickers 300 mN. Increasing the sintering temperature leads to a multiple increase in hardness, but increases the scatter of individual values of the indentation.

**DEPENDENCE OF THE SIZE OF TITANIUM NITRIDE PARTICLES
AND THEIR AGGLOMERATION PROPERTIES FROM
PARAMETERS PLASMODYNAMIC SYNTHESIS**

A. A. Sivkov, D. Yu. Gerasimov, A. A. Evdokimov, A. I. Usikov

Tomsk Polytechnic University, Tomsk, Russia, sivkovaa@mail.ru

Synthesis of TiN occurs at the front of the bow shock wave, followed by spray-crystallization and the formation of particles of superhard material.

One of the factors can take to improve the content of the main phase cTiN, as well as possibly influencing the dispersion of UDP, is a pressure gas (nitrogen) atmosphere in the cell-reactor.

It is known that the particle size of crystalline materials formed from the liquid phase, as in this way is determined by the crystallization and tempering. The smaller this time, the smaller the size of the crystallites. When spraying a liquid phase material synthesized from the free surface jet during quenching speed is determined by two opposing factors, the rate of expansion of embryo-drops and the density of the environment (at the same temperature). Increasing the density by increasing P0 leads to a decrease in the velocity dispersion. In these terms and conditions of the optimal process for minimizing the size of the particles appear when conditions are P0 = 1.0-2.0 a.

Research methods of XRD showed that with increasing content of nitrogen atmosphere P0 cTiN crystal grows to almost 99%. In this case the minimum value of the average coherent scattering region (CSR) takes place at P0 = 1.0-2.0 a. That uniquely corresponds to the above data

Thus, the experimentally established that under these conditions the minimum size of particles in the synthesis of UDP plasmodynamic take place at a pressure of nitrogen atmosphere 1.0-2.0 a. The content of cubic titanium nitride reaches ~ 99% at P0 = 3.0 a. with an average particle size of about 45 nm. These data confirm the hypothesis about the growth of the size of the agglomerates with decreasing size of nanoparticles powder cTiN.

RESEARCH OF NANOPOWDERS PROPERTIES PURE AND DOPED METAL OXIDES PRODUCED BY A METHOD OF PULSED ELECTRON BEAM EVAPORATION

S.Y. Sokovnin, A.M Murzakaev, V.G. Il`ves, A.V. Spirina

¹*Institute of Electrophysics Ural Branch of RAS
106 Amundsen Str., Yekaterinburg, Russia, 620016;
sokovnin@iep.uran.ru*

Nanopowders of a pure CeO₂ and ZnO with a high specific surface (210 and 68 m²/g, accordingly) and the same oxides doped by Cu, Fe, C were produced by a method of pulsed electron beam evaporation in vacuum.

Characteristics nanopowders were studied by methods of XRD, high resolution transmission electron microscopy, electronography, DSC-TG, inductively coupled plasma and pulsed cathodeluminescence.

For the first time was established ferromagnetism at room temperature in nanopowders ZnO-Zn-Cu and CeO₂-C which can be connected with high deficiency produced nanopowders.

RESEARCH OF NANOPOWDERS PROPERTIES OF NEW X-RAY CONTRAST SUBSTANCES AND THE PHOSPHORS PRODUCED BY A METHOD OF PULSED ELECTRON BEAM EVAPORATION

S.Y.Sokovnin¹, M. GZuev², V.G. Il`ves¹, A.V. Spirina¹

¹*Institute of Electrophysics Ural Branch of RAS*

106 Amundsen Str., Yekaterinburg, Russia, 620016; sokovnin@iep.uran.ru

²*Institute of Solid State Chemistry of the Ural Branch of RAS*

91, Pervomaiskaya ul., GSP, 620990, Yekaterinburg

For the first time using pulsed electron evaporation were produced nanopowders of YTaO₄, LaTaO₄ X-ray contrast substances and phosphors Sr₂Y₈(SiO₄)₆O₂:Eu with oxyapatite structure with a specific surface to 184 m²/g.

Characteristics nanopowders were studied by methods of XRD, electronic microscopy of the high permission, electronography, pulsed cathodeluminescence and photoluminescence.

The analysis of a photoluminescence spectrum of phosphor has shown that the luminescence spectrum has changed in comparison with a micropowder of the same structure. The Eu³⁺ + luminescence spectrum contains smaller number of lines, than Eu³⁺ + spectrum of the micron size particles. Besides the shift of spectral lines was observed. There was also a reduction of intensity red and increase orange spectrum lines. After roasting on the air the nanophosphor spectrum of luminescence Eu³⁺ + has coincided with that one for microparticles. Thus, the effect of quantum restriction on position of power levels was observed, apparently. The size of particles of a phosphor has influenced its spectral structure.

X-ray contrast properties nanopowders researches were tested in odontology, essential influence, especially in 3D geometry is established.

**RESEARCH OF PROPERTIES NANOPOWDERS AND COVERINGS
FROM ALUMINA IRON DOPED, PRODUCED BY A METHOD OF
PULSED ELECTRON BEAM EVAPORATION**

S.Y. Sokovnin, A.M Murzakaev, V.G. Il`ves, A.V. Spirina

¹*Institute of Electrophysics Ural Branch of RAS
106 Amundsen Str., Yekaterinburg, Russia, 620016; sokovnin@iep.uran.ru*

Nanopowders with a high specific surface and coverings from alumina doped Fe were produced by a method of pulsed electron beam evaporation.

Structural and optical characteristics of materials were studied by methods high-temperature XRD, electronic microscopy, electronography, pulsed cathodeluminescence.

Phase transformations in nanopowders were studied by method synchronous DSC-TG.

For the first time magnetic properties nanopowders Al₂O₃-Fe were studied at room temperature. Coverings of micron thickness have prospects for their using in dosimetry, optoelectronics and elements spintronic..

ON BOUNDLESS WIRE MESH RESISTANCE COMPUTATION

I.F. Spivak-lavrov, M.S. Kurmanbai

*Aktobe's State Zhubanov University named after K.Zhubanov, Aktobe,
Kazakhsta, spivakif@rambler.ru*

Irodov's problem book on General Physics [1] contains the following problem: «There is a boundless wire mesh with square cells. The resistance of each conductor between two adjacent mesh units of the mesh equals r . Find resistance R of the mesh between two adjacent mesh units A and B .» In the problem book of 2003 this problem is numbered 3.154. This problem is followed by the *Instruction*: “Apply the principles of symmetry and superposition.”

The book [1] offers the solution to the problem. We cite it below. «Let us mentally switch voltage source U to points A and B . Then $U = IR = ir$, where I is current in the leading wire, and i is current in conductor AB . Current i can be presented as the superposition of two currents. If current I “in

flowed” point A and spread upon the net as infinity, current $I/4$ would flow through conductor AB due to symmetry. Similarly, if current I got into the mesh out of infinity and “out flowed” from point B , current $I/4$ would run through conductor AB . If we apply both solutions we will receive $i=I/2$. Therefore, $R=r/2$.»

This solution is nice and graceful except for one thing – this solution seems approximate as it has been found according to the superposition principle, which in this case is performed approximately. Actually, the same superposition principle implies that when current I “in flows” point A , voltage $\varphi_A=U/2$ is to be applied to this point. (It is supposed that the potential on the infinity equals zero). Similarly, voltage $\varphi_B=-U/2$ is applied to point B . If both voltages are applied simultaneously, the symmetry in the current distribution in points A and B will be broken due to the interrelation of the potentials and the answer for the problem will be different. Moreover, it can be said that the mutual influence of the potentials will result in the fact that the current in conductor AB will exceed $I/2$ and consequently, resistance $R>r/2$.

We have found the exact solution of this problem which comes to the solution of quadratic equations by means of equivalent schemes. The whole surface is divided into two half-surfaces and two endless chains. At that, each resistance r along the division lines is replaced by two parallelly joined resistances $2r$ each.

We have got the result $R=0,54119610\dots r$ which is slightly different from the result $R=0,5r$ obtained according to the superposition principle approximation. We have also considered the distribution of currents in point A . If current I comes to point A it will be distributed as follows: similar currents $\cong 0,190I$ will run through resistances going up and down from point A , current $\cong 0,541I$ will run through mesh joints A and B , and current $\cong 0,079I$ will run in the opposite direction.

We have also found the solution of problems on an endless cubic lattice from identical resistances covering the whole space.

References

1. Irodov I.E. Problems on General Physics. Study guide. Ed. 6. – St.P.: Izd. “Lan”, 2003.– 416p.

STRUCTURAL TRANSFORMATIONS OF TECHNICAL CARBON BLACK T900 UNDER THE ACTION OF A HIGH-ENERGY-DENSITY PULSED ELECTRON BEAM

**A. D. Teresov, Yu. G. Kryazhev¹, N. N. Koval, V. A. Likholobov²,
V. A. Drozdov², M. V. Trenikhin²**

*Institute of High Current Electronics SB RAS, Tomsk, Russia,
tad514@sibmail.com*

¹*Omsk Scientific Center SB RAS, Omsk, Russia*

²*Institute of Hydrocarbon Processing, Omsk, Russia*

In recent years, the physics and chemistry of carbon-based nanostructured materials (CNMs) including fullerenes, nanooxions, nanotubes, graphenes, nanodiamonds, nanoglobules, nanowires, nanoporous composites, etc., are high-priority R&D directions in world science and technology. Differing in the character of interatomic bonds, configurations, dimensions, and mutual organization of structural elements, various types of carbon nanoparticles and CNMs possess specific properties and admit original (sometimes nontraditional) applications. CNMs are frequently synthesized using an approach that is based on the transformation of an initial carbon-containing substance under the action of high-energy factors (explosion, electric discharge, high temperature, intense irradiation, etc.) that cause the dissociation of carbon-carbon bonds and the formation of new, energetically favorable structure modifications.

In this paper, as the original sample was used technical carbon black T900. Irradiation of carbon black was carried out on the vacuum electron-beam installation "SOLO", which is based on an electron source with plasma cathode based on a pulsed low pressure arc discharge with a grid-stabilized cathode plasma boundary and open boundary of the anode plasma. Source allows to generate an electron beam with the parameters: the energy density per pulse up to 80 J/cm², pulse duration of 20-200 μs, the energy of electrons up to 25 keV, beam current up to 300 A, pulse repetition rate of 0.3-15 Hz. All parameters can be adjusted smoothly and independently of each other.

In the experiments, the irradiated carbon black T900 was placed in a graphite crucible with a hole Ø12 mm, a depth of 10 mm. The crucible was closed by a copper diaphragm with a hole Ø5 mm. The irradiation was performed with the following parameters: the energy density per pulse of 40 J/cm², pulse duration of 100 μs, the energy of electrons 15 keV, the number of pulses of about 100, the pulse repetition frequency of 1 Hz, the pressure in

the chamber (Ar) $3,5 \cdot 10^{-2}$ Pa. During irradiation on the inner side of the diaphragm was deposited film of carbon particles, which later was investigated using high resolution transmission electron microscopy.

Investigation of the initial carbon black T900 has shown that it mainly consists of spherical particles with the size of 50-400 nm. The internal structure of the particles is close to amorphous with a low degree of ordering of graphene layers, it is confirmed by electron microdiffraction.

After electron-beam irradiation in the residual fraction, collected from the inner surface of the diaphragm, there is a deep internal restructuring, which resulted in the formation of particles with original morphologies, reminiscent of the rosebud cut. Transmission electron microscopy and microdiffraction pattern of modified particles showed the presence of an ordered structure consisting of close-packed graphene layers.

Thus, we have demonstrated the possibility of using a submillisecond pulsed electron beam with high energy density to induce structural transformations of globular carbon black particles with the formation of new CNMs.

INVESTIGATION OF FIELD EMISSION PROCESS FOR ULTRATHIN FILMS OF ZIRCONIA: VOLT-AMPERE DEPENDENCES AND SPECTRA FINE STRUCTURE

I.S. Turmyshev, O.R. Timoshenkova, A. M. Murzakaev

*Institute of Electrophysics UB RAS, 106 Amundsena St.,
Ekaterinburg, Russia, ivatur@rambler.ru*

Thermofield emission cathodes based on ZrO₂/W heterostructures are widely used as a point electron source nowadays. But a life time of the cathodes is about 1000 of hours. Structure and topology of the needle end becomes unstable due to thermo-diffusion processes which take place under these terms. There are several works seeking to increase the stability of the cathodes, but in general the authors confined themselves to investigation of Volt-Ampere characteristics.

At present issue results of simultaneous study of Volt-Ampere characteristics and energy spectra of such cathodes are discussed just under field emission terms. Firstly, needle shaped tungsten cathodes were coated by thin film of ZrO₂ by means of thermo-field diffusion methods under ultra high vacuum conditions. In this case the tungsten emitters were used as reference

patterns and their characteristics were measured before the coating process. It is shown that Volt-Ampere characteristics of coated emitters plotted in Fowler-Nordheim coordinates has non-linear character contrarily to “metallic” Volt-Ampere characteristics.

Such behavior of Volt-Ampere characteristics may be attributed to complicated energy spectra obtained during Volt-Ampere characteristics measurement and complex electronic structure of thin film. There are two peaks on the spectra plot with 3-5 eV distance between them depending on emission voltage. It is shown that energy spectra of coated cathodes have fine structure. Fine structure of energy distributions are investigated for several thickness of zirconia film. Behavior of fine structure and general spectra transformations are shown for different emitting fields versus films thickness.

Finally, the work function of the coated cathodes is lower by 2 eV at an average in comparison to pure W cathodes.

**RESEARCHES OF THE NANO-STRUCTURED
GLASS-CRYSTALLINE MATERIALS PRODUCED BY
PLASMA TECHNOLOGY**

O.G. Volokitin, A.V. Lucenko, V.V. Shehovcov

*Tomsk state university of architecture and building, Tomsk, Russia,
volokitin_oleg@mail.ru*

Comprehensive researches of glass-crystalline material was conducted on the atomic - molecular level, that is a good scientific groundwork, on base of it you can create the materials with specified structural elements and learn how to modify these structural elements.

Possibility of producing glass-crystalline materials in the conditions of high temperature with use low-temperature plasma and electro-arc warming up on the basis of natural minerals and waste products was investigated. At use of the given ways at the expense of action of heats there is an intensification of process of melt producing, allowing to receive glass-crystalline materials on the basis of waste products and natural minerals with considerable reduction of producing time and power consumption decrease that at traditional technology is not possible.

**FORMATION OF MULTILAYERED COATINGS ON THE BASIS
OF ALTERNATING NANOLAYERS CrN/AlN AND THEIR
TRIBOLOGICAL PROPERTIES**

**A.V. Voronov, V.P. Sergeev, M.V. Fedorishcheva,
M.P. Kalashnikov**

*Institute of Strength Physics and Materials Science of SB RAS, Tomsk,
634021, Russia, Academicheskii, 2/4, retc@ispms.tsc.ru*

One of priority directions of a modern science and techniques is studying of methods of formation and properties of new materials, in particular, creation multicomponent, nanocrystalline coatings with grain size no more 100 nm. Recently wear-resistant nanocomposite coatings for the cutting tool on the basis of Cr-Al-N system attract great attention. In comparison with Ti-Al-N coatings type they have higher oxidising stability at high speeds of cutting due to formation of a protective layer of chrome and the aluminium which suppress diffusion of oxygen in material.

The purpose of the present work is producing of nanolayer coatings on the basis of CrN/AlN system at simultaneous work of two magnetrons and an ionic source, and studying of influence of parametres of magnetron deposition as function of structurally-phase state, a chemical compound and tribological properties of coatings.

Deposition of coatings was carried out using vacuum installation "KVANT" type. Targets from aluminium and chrome 120 mm in diameter used for magnetrons work. Arc ionic source used to bombard surface of coatings by chrome ions. Coatings deposited on samples of tool steel 15×6×6 mm in size.

Changing capacities of magnetrons by current of arc sources, speed of rotation of a rotary table, received layered coatings on the basis of CrN/AlN with a various relation of the composition of chrome nitrides and aluminium in a coating. This facts lead to a certain structurally-phase state and properties of such coatings. Using X-ray analysis and TEM was established that there are two basic phases Cr₂N having close-packed hexagonal structure a lattice and AlN with close-packed hexagonal structure P63/mc having wurtzite type. Grains size of basic phases is 5... 20 nm. There are thin layers of Cr₂Al and Al₈Cr₅ intermetallide on boundaries. Effect of ionic bombardment as function of tribological behavior of coatings is established.

Investigation of adhesion and tribological behavior of CrN/AlN multilayers coatings were carried out using scratch-testing "REVETEST-RST" and "NanoHardnessTester".

PRODUCTION OF HYDROGEN AND CARBON NANOMATERIALS FROM NATURAL GAS FOR HYDROGEN STORAGE DEVICES

**A. G. Zherlitsyn^a, V. P. Shiyan^a, V. S. Kositsyn^a, L.V.Gulidova^a,
A.M.Lider^a, P.S.Postnikov^a, M.E.Trusova^b**

^a*Institute of Physics and Technology at TPU, Tomsk, Russia*

^b*Institute of High Technology Physics at TPU, Tomsk, Russia*

E-mail: zherl@tpu.ru

Hydrogen, as a highly efficient and environmentally clean source of energy, is a very promising gas for use in power engineering. However, an effective method to produce, store and transport hydrogen has not been found yet. A great deal of attention has been focused on the development of new and effective technology for the production, storage and transportation of hydrogen. In this paper we present the technology for production of hydrogen from natural gas and carbon nanomaterials (CNM) using microwave energy. The idea of this technology is that hydrogen and carbon nanomaterial are produced as a result of the conversion of natural gas, which occurs in a flow reactor in the presence of microwave discharge and a metal catalyst [1]. The resulting CNM contains carbon nanotubes and nanofibers (30-60%), amorphous carbon and a small amount (less than 1%) of polyhedral nanoparticles of carbon as well as graphite nanoparticles. To isolate the carbon nanotubes and nanofibers, this material is further undergo an additional stepwise chemical treatment using oxidation methods. The result is a purified carbon nanomaterial with a total content of carbon nanotubes and nanofibers of up to 90%.

The paper also presents the results of studies on hydrogen sorption capacity of CNM samples with different content carbon nanotubes. The maximum sorption capacity of the material was achieved at low temperature (243 °C) and high pressure (10 atm.) and found to be more than 16 wt. %.

This work was supported by the Federal Program "Scientific and scientific-pedagogical personnel for innovative Russia" for 2009-2013.

1. RF Patent № 2317943 Publ. 02/27/2008 Mr. Bull. № .6 // Y.V. Medvedev, A.G. Zherlitsyn *et al.* A method and apparatus for producing carbon and hydrogen from hydrocarbon gas.

SPRAY PYROLYSIS TECHNIQUE FOR CERAMIC POWDERS SYNTHESIS

A. S. Zhukov¹, V. A. Arkhipov^{1,2}, S. V. Zmanovsky³, S. S. Bondarchuk^{1,2}

¹ *Tomsk State University, Tomsk, Russia, leva@niipmm.tsu.ru*

² *Institute for Problems of Chemical and Energetic Technologies, SB RAS, Biisk, Russia*

³ *Limited Liability Company "SUAL-PM", Shelekhov, Russia*

Optimisation of ceramic powders (mainly, oxides of metals) production technology by the plasmachemical synthesis method in an actual problem in connection with a steady tendention to the extension of these materials application spheres. Efficiency of the plasmachemical synthesis technology is determined by its productivity, power consumption and financial profitable in obtaining a given output structure of the product – the particles of metals oxides.

The apparatus part of plasmachemical method and nanopowders synthesis technology is based on a high-frequency method for heat carrier generation, supplied to the reactor part of the plant together with a precursor solution. Fine-grained powders are synthesized by thermochemical decomposition of the liquid sprayed reagents in a high-temperature heat carrier, and the process takes place in a cylindrical reactor of vertical type.

One of the ways of the industrial plants efficiency increasing, allowing organizing the optimal high-performance process of a wide class materials with desired properties obtaining is the application of governing processes in the reactor mathematical modeling.

The development of the mathematical model includes a multifactor analysis of a problem of multicomponent two-phase chemically reacting medium parameters calculating, and detailed study of heat and mass transfer phenomena in a drop of spray reagent and drop interaction with the carrier gas phase. Multifactor optimization across the entire spectrum of these processes is necessary for the creation of controllable ceramic powders synthesis technology.

Plasmachemical synthesis process is multistage and includes liquid precursor atomization with formation of polydispersed drops in the reactor volume, drops motion in a flow of gaseous heat carrier agent, drops heating and evaporation accompanied by diffusion and crystallization of metal salt inside drop, a thermolysis of salt with formation of a microporous film of metal oxide at temperature increasing and, at last, its sintering in the form of a solid or hollow particle.

In particular, when used as a precursor an aqueous solution nonagidrate of aluminium nitrate salt $\text{Al}(\text{NO}_3)_3 \cdot 9\text{H}_2\text{O}$ process of thermolysis of the crystallized inside drop salt starts at its heating from above 135°C . Thus originally basic salt $\text{Al}(\text{OH})_2\text{NO}_3 \cdot 1.5\text{H}_2\text{O}$ is formed, and at higher temperatures (from above 200°C) there is its decomposition to the amorphous aluminum oxide according to the chemical reaction

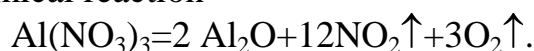

Analysis of the plasmachemical synthesis separate stages has shown that formed of powder particles morphology occurs at the stage of drop evaporation. Consider the basic processes occurring simultaneously in a solution drop on the stage of evaporation. They include temperature change at the drop of heated, dissolvent evaporation from a drop surface, diffusion of salt toward the center of the drop, salt crystallization and removal of the remained dissolvent (drop drying).

In the present work the physical-mathematical model of processes of liquid sprayed reagents thermochemical decomposition in the high-temperature heat carrier, based on simultaneous consideration of a two-phase turbulent flow in the reactor volume and heat and mass transfer in the precursor drop is presented.

Contents

Plenary sessions

- Musil J.** 3
HARD NANOCOMPOSITE COATINGS: THERMAL STABILITY, OXIDATION RESISTANCE AND TOUGHNESS
- Mazarakis M.G., Kim A.A., Savage M.E., Fowler W.E., LeChien K., Lucero D.J., Matzen M.K., McKee R.G., Natoni G., Porter J.L., Roznowski S.A., Sinebryukhov V.A., Stoltzfus B.S., Stygar W.A., Wakeland P.E.** 5
OPERATING THE FIRST WATER-INSULATED MYKONOS II LTD VOLTAGE ADDER
- Lisitsyn V. M.** 6
FORMATION AND EVOLUTION OF THE RADIATION DEFECT IN THE IONIC CRYSTAL

15th International Conference of Radiation Physics and Chemistry of Condensed Matter

Elementary processes

- Abdel-Moneam Y. K., Polisdova E. F., Othman H. A., Madkour M. M.** 8
PREPARATION AND OPTICAL PROPERTIES OF TITANIUM DIOXIDE NANOPOWDER
- Abuova F.U., Useinov A.B., Akilbekov A.T., Kotomin E.A., Piskunov S.** 8
FIRST-PRINCIPLES CALCULATIONS OF RADIATION DEFECTS IN MAGNESIUM FLUORITE
- Alekseev V.D., Trefilova L.N., Yakovlev V.Yu., Meleshko A.N., Charkina T.A.** 10
COLORATION MECHANISM OF CsI(Tl) UNDER IRRADIATION
- Anan'ev V.A., Kriger L. D., Sorokina I. A., Belyh A. B.** 11
THE IMPACT OF BA^{2+} AND SO_4^{2-} ON THE EFFICIENCY OF PEROXYNITRITE FORMATION UNDER PHOTOLYSIS OF KNO_3

Contents

Artyomov K. P., Ryzhov V. V., Tarakanov V. P. PARTICLE-IN-CELL SIMULATION OF POLARIZATION RADIATION	12
Badyrova N. M. GEOMETRIC ANHARMONICITY WITHAN EXAMPLE OF MODEL CALCULATIONS FOR POLYETHYLENE	13
Baskakov D. B., Zilov S. A., Rakewitch A. L. CORRELATING POLARIZED COMPONENTS OF ROTATING CRYSTAL COLOR CENTERS LUMINESCENCE	14
Chinkov E. P., Shtan'ko V. F., Stepanov S. A. OPTICAL SPECTROSCOPY OF ALKALINE EARTH METAL FLUORIDE CRYSTALS UNDER CASCADE AND SIMULTANEOUS PULSED EXCITATION	15
Dubtsov I.N., Trefilova L.N., Lisitsyna L. A., Timoshenko N. N., Zelenskaya O.V., Gudzenko L. V., Sofronov D. S. COMPLEX EMISSION CENTERS IN SCINTILLATOR LiF(WO ₃)	16
Ivanov V. Yu., Sedunova I. N., Gerasymov I. V., Sidletskiy O. Ts., Pustovarov V. A. UV-LUMINESCENCE IN Lu ₂ SiO ₅ -Ce AND Lu ₂ Si ₂ O ₇ -Ce CRYSTALS AT VUV- AND SOFT X-RAY EXCITATION	18
Kalenskii A.V., Kriger V.G., Zvekov A.A., Grishaeva E.A., Zykov I.Yu., Nikitin A.P. THE MICROCENTER HEAT EXPLOSION MODEL MODERNIZATION	19
Kopytov A.V., Antropova E.V. ELASTIC WAVES IN CRYSTALS WITH CHALCOPYRITE STRUCTURE	20
Kortov V., Nikiforov S., Zvonarev S., Ustyantsev Yu. LUMINESCENT HIGH-DOSE DETECTORS ON THE BASIS OF CRYSTALLINE AND NANOSTRUCTURED MATERIALS	21
Kuznetzov A.Yu., Sobolev A.B., Makarov A.S., Botov M.A. AB INITIO CALCULATIONS OF DEFECTS IN ALUMINA CRYSTALS	22
Kuznetzov A.Yu., Botov M.A., Makarov A.S., Sobolev A.B. OPTICAL AND ELECTRONIC PROPERTIES OF POINT DEFECTS IN CALCIUM AND MAGNESIUM OXIDES	23
Lisitsyna L., Korepanov V., Lisitsyn V., Petikar P. SPECTROSCOPIC PROPERTIES OF LiF CRYSTALS DOPED WITH W, Ti AND Fe OXIDES	23

Contents

Makarov A.S., Kuznetsov A.Yu., Sobolev A.B., Botov M.A. FIRST-PRINCIPLES MODELING OF THE SELF-TRAPPED EXCITON NONRADIATIVE DECAY IN ALKALI HALIDES	24
Malchukova E., Nepomnyaschich A., Boizot B. ON THE QUESTION OF VARIETY OF RE IONS LOCAL ENVIRON- MENTS IN OXIDE GLASSES	25
Miklin M.B., Kriger L.D., Lyrshikov S.Yu. RADIOLYSIS OF ALKALI-EARTH NITRATES	26
Myasnikova A., Mysovsky A., Paklin A., Shalaev A. COPPER IMPURITY IN LiF and NaF CRYSTALS FROM AB INITIO CALCULATION: STRUCTURE AND OPTICAL PROPERTIES	26
Myasnikova L.N., Zhanturina N.N., Shunkeyev K.Sh., Aliev B.A., Grinberg M., Tkachenko V.S. THE MODELING OF INTRINSIC LUMINESCENCE IGNITION EF- FECT IN CRYSTAL KI AT LOW TEMPERATURE ELASTIC STRESS	28
Nepomnyashchikh A., Shalaev A., Paklin A., Shendrik R., Bobina N., Myasnikova A. GROWTH AND OPTICAL CHARACTERIZATION OF COPPER- DOPED LITHIUM FLUORIDE SINGLE CRYSTALS	29
Nikiforov S.V., Kortov V.S. GENERAL INTERACTIVE TRAP SYSTEM MODEL FOR THERMOLUMINESCENCE OF $Al_2O_3:C$ SINGLE CRYSTALS	30
Nurakhmetov T.N., Kainarbay A., Salikhodja D.M., Zhunusbekov A., Sadykova B.M., Pazylbek C., Karipbayev Zh.T. RECOMBINATIONAL AND RADIOSTIMULATED PROCESSES IN SULPHATES WITH CORRELATED DEFECTS	32
Ogorodnikov I.N., Kiseleva M.S., Yakovlev V.Yu. A PULSED OPTICAL CHARACTERIZATION OF OPTICAL CRYSTALS WITH MOBILE CATIONS	33
Ogorodnikov I.N., Pustovarov V.A., Yakovlev S.A., Isaenko L.I., Zhurkov S.A. A LUMINESCENCE SPECTROSCOPY STUDY OF NON-LINEAR OPTICAL CRYSTALS $K_2Al_2B_2O_7$	34
Oleshko V.I., Gorina S.G., Korepanov V.I., Lisitsyn V.M. SPECTRAL AND KINETIC CHARACTERISTICS OF LUMINES- CENCE OF AlGaN/InGaN/GaN HETEROSTRUCTURES EXCITED BY HIGH-CURRENT ELECTRON BEAM	35

Contents

Oleshko V.I., Vil'chinskaya S.S., Kupchishin A.I., Gorina S.G. LUMINESCENCE OF ZINC SELENIDE CRYSTALS EXCITED BY ELECTRON BEAM PULSE	36
Ovcharenko N.V., Yakovlev V.Yu., Ganja Yu.S., Trefilova L.N., Zelenskaya O.V., Rebrova T.P., Gayduk O.V., Sofronov D.S. SCINTILLATION RESPONSE OF CsI(WO ₄) TO IRRADIATION	37
Petrenko M.D., Kopchuk D.S., Kovalev I.S., Ogorodnikov I.N., Raykov D.V., Zyryanov G.V. LUMINESCENT PROPERTIES OF NEW ORGANIC LUMINOPHORES	38
Prosekina E.A., Radzhabov E.A. 5D-4F LUMINESCENCE OF ND ³⁺ , ER ³⁺ AND TM ³⁺ IONS WITH SEV- ERAL CONCENTRATION IN FLUORIDES	39
Zh.M. Salikhoja, T.N. Nurakhmetov, A.Zh. Kainarbai, B.M. Sadykova, D. Mussakhanov, A. Dzhunusbekov, A. Agibetova QUANTUM-CHEMICAL MODELING OF RADIATION DE- FECTS FORMATION PROCESSES IN CRYSTALS LiKSO ₄ , LiNaSO ₄ , CaSO ₄	40
Sedunova I. N., Ogorodnikov I. N. , Ivanov V. Yu. , Pustovarov V. A. ENERGY TRANSFER PROCESSES IN Li ₆ (Gd,Eu,Y)(BO ₃) ₃ BULK CRYSTALS AND FIBERS	42
Sergeyev D. M. , Shunkeyev K. Sh. ANDREEV REFLECTION OF PSEUDO-CORRELATED PAIRS ELECTRONS IN THE SYSTEM «SUPERCONDUCTOR– FLUCTUATION SUPERCONDUCTOR–SUPERCONDUCTOR»	43
Shendrik R. Y., Radzhabov E. A., Nepomnyashchikh A. I. ENERGY TRANSFER MECHANISMS IN ALKALI-EARTH FLUO- RIDES DOPED WITH PR ³⁺ IONS	44
Shteiner E.A., Afanasyev A.D. STUDY OF SeH - SeH DIMERS IN KCl CRYSTAL	45
Shunkeyev K.Sh., Barmina A.A. , Bizhanova K.B. , Sergeyev D.M., Shunkeyev S.K. DIPOLE CURRENTS OF THERMOSTIMULATED DEPOLARIZA- TION IN ALKALI HALIDE CRYSTALS AT THE LATTICE SYM- METRY LOWERING	46
Sizova T. Yu., Radzhabov E. A. RADIATION DEFECTS ON ALKALINE EARTH FLUORIDES DOPED WITH TRIVALENT IONS	47

Contents

Smirnova D. E. , Starikov S. V. , Stegailov V. V. ATOMISTIC SIMULATION OF STRUCTURE AND PROPERTIES OF SOLID AND LIQUID URANIUM	48
Spiridonova T. V., Kortov V. S. , Zvonarev S. V. EXPLANATION AND TESTING OF THE MODEL FOR COMPUTER CALCULATIONS OF LUMINESCENCE SPECTRA AND PHOTOLU- MINESCENCE DECAY KINETICS UNDER PULSED LASER EXCI- TATION IN SILICON DIOXIDE CRYSTALS	49
Surdo A.I., Sokovnin S.Yu., I. I. Milman, Il'ves V. G., Vlasov M.I., Abashev R.M., Boldesh A.V. OPTICALLY AND THERMALLY STIMULATED LUMINESCENCE OF NANOPOWDERS AND THIN FILMS OF ALUMINUM OXIDE	50
Trefilova L.N., Yakovlev V.Yu., Alekseev V.D., Meleshko A.N., Mitichkin A.I. RADIATION DAMAGE OF CsI AND CsI:TI CRYSTALS CONTAIN- ING IMPURITIES OF CARBONATE AND HYDROXIDE	52
Vlasov M.I., Surdo A.I., Milman I.I., Solomonov V.I., Spirina A.V. LUMINESCENCE AND DOSIMETRIC PROPERTIES OF THE (Er ³⁺ ,Dy ³⁺):YAG CRYSTALS	53
Vostrov D. O. , Sedunova I. N. , Ogorodnikov I. N. , Ivanov V. Yu. LUMINESCENCE OF Li ₆ (Gd,Y)(BO ₃) ₃ :Ce FIBERS	55
Zhidkov I. S., Zatsepin A. F. , Kukhareno A. I. , Yakovlev V. Yu. , Cholakh S. O. KINETICS OF SHORT-LIVING OPTICAL ABSORPTION IN BINARY LEAD SILICATE GLASSES	56
Zhuravlev J.N., Lisitsyn V.M., Morozova E.Ju. THE CRYSTAL STRUCTURE OF DINITIDE-NITRIDE N ₂ MN (M: Cu, Ag)	57

Nonlinear effects

Aduev B.P., Belokurov G.M., Grechin S.S., Liskov I.Ju. INITIATION OF PENTAERYTHRITOL TETRANITRATE MONOCRYSTALS BY IMPULSE BEAM OF ELECTRONS	59
Aduev B.P., Nurmukhametov D.R., Furega R.I. LASER INITIATION OF PENTAERYTHRITOL TETRANITRATE WITH ADDITIVES OF ALUMINIUM AND ALUMINA NANOPARTICLES	60
Ananyeva M. V., Kriger V. G., Kalenskii A. V., Zvekov A. A., Borovikova A. P., Grishaeva E. A., Zikov I. Yu. COMPARATIVE ANALYSIS OF THE ENERGETIC MATERIALS EX- PLOSION PROCESS'S CHAIN AND THERMAL MECHANISMS	61
Atuchin V.V., Alekseev S.V., Andreev Yu.M., Kokh K.A., Lanskii G.V., Losev V.F., Lubenko D.M., Puchenko Yu.N., Shaiduko A.V., Svetlichnyi V.A. IMPACT OF HIGH INTENSITY FS AND NS OPTICAL PULSE EX- POSES UPON DOPED GASE	62
Baryshnikov V.I., Krivorotova V.V. GENERATION OF LASER LINES AND NON-LINEAR SELF- ADDITION THEIR FREQUENCIES AT POWERFUL ELECTRON- BEAM PUMPING OF ER:BaY ₂ F ₈ CRYSTALS	63
Borovikova A.P., Kriger V.G., Kalenskii A.V., Ananyeva M.V., Zvekov A.A. THE TIME-SPACE PARAMETERS OF THE EXPLOSIVE DECOMPO- SITION OF ENERGETIC MATERIALS MOVING REACTION WAVE	65
Damamme G., Zarbout K., Moya G., Si-Ahmed A. SOME PROGRESS IN EXPERIMENTAL CHARACTERIZATION OF CHARGE TRANSPORT AND TRAPPING IN INSULATORS ASSOCIATED WITH SEC- ONDARY ELECTRON EMISSION	66
Grishaeva E.A., Kalenskii A.V., Zvekov A.A., Kriger V.G., Ananyeva M.V., Kolmogorova O.N. THE TRANSITION FROM SLOW DECOMPOSITION PROCESS INTO THE SELF-ACCELERATED MODE IN THE ENERGETIC MATERI- ALS	68
Ismatov N.B., Tashmetov M.Yu. LOW-TEMPERATURE STUDY OF MAGNETIC SUSCEPTIBILITY IN NONSTOICHIOMETRIC TITANIUM CARBONITRIDE	69

Contents

Khaneft A. V., Duginov E. V., Dolgachev V. A., Ivanov G. A. THE CRITERION OF INITIATION FOR EXPLOSIVE MATERIALS WITH THE FUSING TEMPERATURE THAT IS LESS THAN THE IG- NITION TEMPERATURE BY THE SHORT LASER BEAM	70
Khaneft A.V., Ivanov G.A. RADIATION-THERMAL MECHANISM OF INITIATION OF PETN IN THE ABSORPTION REGION OF THE ELECTRON PULSE	72
Krashenin V.I., Gazenaur E.G., Rodzevich A.P., Kuzmina L.V., Gritchina V.G., Sugatov E.V. THE RELAXATION OF NONEQUILIBRIUM CARRIERS OF CHARGES IN PHOTO- AND ELECTRO-RAISED OF SILVER AZIDE	73
Kuznetsov A.V., Martynovich E.F. SIMULATION OF FILAMENTATION OF EXTREMELY INTENSE FEMTOSECOND LASER PULSES IN CRYSTALLINE DIELECTRICS	74
Martemyanov S.M., Lopatin V.V. INVESTIGATIONS ON PYROLYTIC DECOMPOSITION OF OIL SHALE BY THE PLASMA CHANNEL	75
Medvedev N. N., Starostenkov M. D. DISCRETE BREATHERS ON THE 3D MODEL OF Pt ₃ Al WITH L ₁₂ ORDER	76
Oleshko V.I., Lisitsyn V.M., Lysyk V.V., Skripin A.S., Tsipilev V.P. MECHANISM OF THE HOT CENTERS FORMATION IN PETN MONOCRYSTALS AT THE EXPLOSION INITIATION BY HIGH- CURRENT ELECTRON BEAM	76
Oleshko V.I., Lysyk V.V. ATOM AND ION LUMINESCENCE OBSERVED DURING EXPLOSION OF HEAVY METAL AZIDES IN VACUUM	78
Ovchinnikov V., Tsipilev V., Yakovlev A. TO A QUESTION ABOUT OPTICAL PROPERTIES OF PRESSED POWDERS OF PENTAERYTHRITOL TETRANITRATE	79
Ovchinnikov V., Skripin A., Tsipilev V., Yakovlev A. SIMULATION OF RADIATION DIFFUSION IN SCATTERING ME- DIA OF DIFFERENT THICKNESS	80
Ovchinnikov V., Skripin A., Tsipilev V., Yakovlev A. DEPENDENCE OF EXPLOSION INITIATION THRESHOLD OF PETN WITH ABSORPTIVE ADDITIVES ON UNIFORM COMPRESSION PRESSURE OF THE SAMPLE	81

Contents

Ramazanova E.E., Shabanov A.L., Huseynov M.A. FORMATION OF STRATOSPHERIC OZONE FROM CARBON DIOXIDE, AMMONIA FROM METHANE AS A RESULT OF PHOTONUCLEAR REACTIONS	82
Razin A., Skripin A., Tsipilev V., Yakovlev A., Damamme G., Malys D. INITIATION OF PETN EXPLOSIVE DECOMPOSITION BY CO ₂ -LASER	83
Razin A., Tsipilev V., Morozova E. INITIATION OF DETONATION OF HEAVY METALS AZIDE BY CO ₂ LASER	84
Sadovnichii D.N., Milekhin Yu.M., Lopatkin S.A., Zhgun D.V., Vazhov V.F., Butenko E.A., Malinin S.A. MICROSECOND ELECTRICAL BREAKDOWN INFLUENCE ON POLYMERIC ENERGY-INTENSIVE SYSTEMS FILLED WITH DISPERSED ALUMINUM	85
Tsipilev V., Razin A., Skripin A., Lisitsyn V., Damamme G., Malys D. TO A QUESTION ABOUT PREDETONATION STAGE OF EXPLOSIVE DECOMPOSITION OF HEAVY METAL AZIDES	86
Zarko V., Oleshko V., Tsipilev V. FTZDO EXPLOSIVE DECOMPOSITION UNDER LASER AND ELECTRON BEAM ACTION	88
Zhang L.-M., Guo J., Xie J.-J., Chen F., Jiang K., Atuchin V.V., Andreev Yu.M., Izaak T.I., Kokh K.A., Lanskii G.V., Losev V.F., Shaiduko A.V., Svetlichnyi V.A., Vaitulevich E.A. CHARACTERIZATION OF GASE SOLID SOLUTIONS BY OPTICAL BEAMS	89
Zilov S. A., Martynovich E. F., Brykvina L.I., Starchenko A. A. THE PERIODIC STRUCTURE OF COLOR CENTERS DISTRIBUTION IN FILAMENT FORMED BY FEMTOSECOND LASER IRRADIATION IN CRYSTAL MgF ₂	90
Zvekov A. A., Kriger V. G., Kalenskii A. V., Aduiev B. P., Zykov I. Yu., Nikitin A. P. THE DEPENDENCE OF THE EXPLOSIVE DECOMPOSITION CRITICAL ENERGY DENSITY ON PULSE DURATION	92

Surface

Berezin V.M., Troitskiy A.A. SURFACE STRUCTURE FEATURES OF COMPOUNDS WITH MOVEABLE METALLIC SUBLATTICE	94
Grankin V.P., Grankin M.V. STIMULATED BY IONIZING RADIATION ELECTRONIC ACCOM- MODATION OF THE REACTION HEAT IN H-ZnS, ZnS, CdS-Ag SYS- TEMS	95
Grankin D. V. CHEMILUMINESCENCE OF Zn_2SiO_4 -Mn, EXCITED BY UV- RADIATION UNDER THE INFLUENCE OF H-ATOMS WITH THER- MAL ENERGY	96
Khudayberganov S.B., Mukhtarov A.P., Sulaymanov N.T., Akbarov Kh.I. EFFECT OF SURFACE PASSIVATION BY HYDROGEN TO THE STRUCTURE AND ELECTRONIC PROPERTIES OF SILICON NA- NOPARTICLES	98
Korabel'nikov D.V. COMPUTER MODELING OF ATOMIC AND ELECTRONIC STRUC- TURE FOR SODIUM PERCHLORATE SURFACE	99
Makhkamov Sh., Khudayberganov S.B., Normurodov A.B., Mukhtarov A.P. STRUCTURE AND ELECTRONIC PROPERTIES OF THE MIXED HYDROGEN-HYDROCARBON COATED SILICON Si_{29} NANOPAR- TICLES	100
Ryaboukhin O.V., Zyryanov S.S., Kruzhalov A.V., Neshov F.G., Kuznetsov M.V. INVESTIGATION OF STEEL SURFACE IRRADIATED BY PROTONS IN IODINE MEDIUM	101
Sosnov E.A. , Malkov A.A. , Malygin A.A. THE NATURE OF RRL_H CENTERS AT WILLEMITE SURFACE	102
Uglov V.V., Abadias G., Michel A., Zlotski S.V., Dolgolevich N.A., Saladukhin I.A. STRUCTURE-PHASE STATE OF $TiZrSiN$ THIN FILMS IRRADIATED BY HYDROGEN AND XENON IONS.	103
Zhubaev A. K. THERMAL STABILIZATION OF $FeSn-\alpha-Fe(Sn)$ LAYERED SYS- TEM	104

Zhubaev A.K., Mailybaeva G. M. STUDY OF THERMAL STABILIZATION IN Zr-Fe LAYERED SYSTEM	105
Uglov V.V., Buyuk B., Tugrul A. B., Lastovski S.V., Addemir A.O., Bogatyrev Yu.V., Zlotski S.V., Shymanski V.I. THE EFFECTS OF SILICON CARBIDE RATIO AND IRRADIATION DOSE ON BORON CARBIDE-SILICON CARBIDE COMPOSITES	106
<u>Physical basis of radiation-related technologies</u>	
Aliev B.A., Buranbaev M.Zh., Koztaeva U.P., Partizan G., Entibekov Zh., Nakysbekov Zh. THE INFLUENCE OF ELECTRON IRRADIATION ON THE STRUCTURE OF NANOSIZED METAL PARTICLES	107
Amonov M.Z. ON THE NATURE OF COLOR CENTERS IN OPTIC FIBERS AT LOW TEMPERATURES	107
Amonov M.Z. RADIATION OPTIC PROPERTIES OF ZRO ₂ -Y ₂ O ₃ CRYSTALS EXPOSED OXIDATION RECOVER INFLUENCES	108
Amonov M.Z. RADIATION STIMULATED FORMATION OF DEFECT AND MASS SPREAD IN ZRO ₂ -Y ₂ O ₃ P	109
Amonov M. Z., Ahsurov M. Kh., Nuritdinov I., Saidakhmedov K. STUDY OF RADIATION OPTIC CHARACTERISTICS OF MONOCRYSTALS OF SILICATE AND GADOLINIUM.	110
Asanov I. A., Vilisov A. A., Gradoboev A. V., Soldatkin V. S., Tepljakov K. V. FIRMNESS OF LIGHT-EMITTING DIODES FOR THE SUPERFICIAL INSTALLATION OF WHITE COLOUR OF THE LUMINESCENCE TO ACTION OF FACTORS OF RADIATIVE ACTION	111
Baklanova Ya. V., Ishchenko A. V., Denisova T. A., Maksimova L. G., Shulgin B. V., Yagodin V. V. THERMOLUMINESCENCE PROPERTIES OF LITHIUM HAFNATE	113
Bespalov V. I., Krechetov Yu. F., Lazarenko S. E., Shuvalov E. N., Uglov S. R. APPLICATION OF ELECTRON ACCELERATORS FOR X-RAY FLUORESCENCE ELEMENT ANALYSIS	115

Contents

Bryukvina L. I., Rakevich A. L., Martynovich E. F. AGGREGATION AND TRANSFORMATION OF COLOR CENTERS UNDER Γ AND LASER RADIATION IN MAGNESIUM FLUORIDE	116
Dresvyanskiy V.P., Rakevich A.L., Malov S.N., Martynovich E.F. LUMINESCENT PROPERTIES OF NANOSTRUCTURED FILMS BASED ON LITHIUM FLUORIDE OBTAINED BY THE METHODS OF LASER TECHNOLOGY	118
Glazunov D.S., Dresvyanskiy V.P., Bobina N.S., Ivashechkin V.F., Kirpichnikov A.V., Kuznetsov A.V., Nepomnyashchih A.I., Pestryakov E.V., Martynovich E.F. THERMOSTIMULATED LUMINESCENCE OF LiF: Mg, Ti, IRRADI- ATED WITH FEMTOSECOND LASER PULSES IN MODE OF THE FILAMENTATION	119
Gofman I.A., Zhuravlev V.D., Pustovarov V.A. LUMINESCENT SPECTROSCOPY OF MOLYBDATE SOLID SOLU- TIONS $A_{1-x}B_x(\text{MoO}_4)$, $A=(\text{Ca},\text{Pb})$, $B=(\text{Pb},\text{Sr},\text{Ba},\text{Cd})$	120
A. V. Kabyshev, F. V. Konusov, G. E. Remnev HIGH INTENSIVE SHORT PULSED IONS IMPLANTATION EFFECT ON ELECTRICAL AND PHOTOELECTRICAL PROPERTIES OF POLYCRYSTALLINE SILICON	122
Kidibaev M. M., Ishchenko A.V., Victorov L.V., Khokhlov K.O., Koroleva T.S., Bektashov A.S., Ivanov V.Yu., Shulgin B.V. THE INTEGRATED GEOINFORMATION SYSTEM FOR REMOTE RADIATION MONITORING	123
Kudiyarov V.N., Lider A.M., Pushilina N.S. RESEARCHING X-RAY INFLUENCE ON THE HYDROGEN REDIS- TRIBUTION IN TITANIUM WITH THE HELP OF PROFILER 2 GLOW DISCHARGE OPTICAL EMISSION SPECTROMETER	125
Lisenkov V. V., Osipov V. V., Platonov V. V. RESEARCH OF ABLATION OF TARGETS FROM HEAT-RESISTANT OXIDES UNDER ACTION OF CO_2 AND FIBER LASERS	126
Litovchenko E.N., Soloviev S.V., Milman I.I., Moiseikin E.V., Surdo A.I. INFLUENCE OF THERMOBEAM PROCESSING ON TL AND OSL PROPERTIES OF THE SOLID-STATE DETECTOR OF IONISING RADIATION ON THE BASIS OF ANION-DEFECTIVE CORUNDUM	127

Contents

Makhkamov Sh., Karimov M., Tursunov N.A., Sattiev A.R., Erdonov M.N., Makhmudov Sh.A., Kholmedov Kh.M. FORMATION AND THE TRANSFORMATION OF CONTAMINANT-DEFECTIVE COMPOSITIONS IN DOPED SILICON AT THERMAL RADIATION INFLUENCE	128
Martynovich E.F. DEFECTS CREATION IN WIDE BAND-GAP CRYSTALS BY AN INTENSE NEAR INFRARED LASER RADIATION	129
Petrovykh K.A., Kortov V.S., Nikiforov S.V., Zvonarev S.V., Ustyantsev Yu.G. SYNTHESIS, CHARACTERIZATION AND LUMINESCENT PROPERTIES OF HIGH DOSE IRRADIATED NANOSTRUCTURED ALUMINA CERAMICS	130
Samigullina R. F., Slobodin B. V., Ishchenko A. V., Shulgin B.V., Victorov L.V., Vakhter V.V., E. Zhevak A. RADIOLUMINESCENCE PROPERTIES OF Cs-METAVANADATES	132
Shamirzaev T.S., Bakarov A.K., Yakovlev V.Yu. ATOMIC STRUCTURE OF SELF-ASSEMBLED InAs/AlAs QUANTUM DOTS: EFFECT OF ELECTRON IRRADIATION AND ANNEALING	134
Shein A. S., Derstuganov A. Yu., Kuntsevich G. A., Krymov A. L., Victorov L.V., Petrov V.L., Shulgin B.V. PORTABLE GAMMA-RADIATION MONITOR ON THE BASIS OF PLASTIC SCINTILLATOR	135
Shulgin B.V., Kruzhalov A.V., Petrov V.L., Victorov L.V., Shein A.S., Andreev V.S., Krymov A.L., Ivanov V.Yu., Cherepanov A.N., Ishchenko A.V., Derstuganov A.Yu., Terekhin V.A., Chernukhin Yu.I., Shutov O.N., Blagoveshchenskii M.N., Grebnyak V.G., Koroleva T.S., Kidibaev M.M. DETECTOR MATERIALS AND DEVICES FOR RADIATION MONITORING	137
Soloviev S.V., Milman I.I., Surdo A.I. CALCULATION OF KINETIC PARAMETRES HIGH-TEMPERATURE TL PEAKS OF ANION-DEFECTIVE CORUNDUM	138
Stepanov S. A., Shtan'ko V. F., Chinkov E. P. SIMULATION OF ELECTRON FIELD EMISSION FROM THE SURFACE OF IONIC CRYSTALS UNDER IRRADIATION BY A PULSED ELECTRON BEAM.	140

Stepanova O.M., Krivobokov V.P. 141
THE ENERGY BALANCE OF THE “CHARGED PARTICLE BEAM-TARGET” SYSTEM AT EROSION OF A METAL SURFACE

Vershinin G. A., Volkov V.A., Buchbinder G.L. 142
LOCAL NONEQUILIBRIUM MASS TRANSFER IN BINARY SYSTEM UNDER CONCENTRATED ENERGY FLUX IRRADIATION

Methods of testing

Abdukadirova I.Kh., Khaydarov T., Karimov Yu. 143
INVESTIGATION OF THE NANOSTRUCTURES FORMATION IN THE IRRADIATED BY γ – QUANTA SINGLE-CRYSTAL SILICON WITH ULTRASONIC METHOD.

Abdukadirova I.Kh. 144
RADIATION-INDUCED OF A DIELECTRIC ABSORPTION IN THE OXIDE ALUMINUM

Abdukadirova I.Kh. 145
ANALYSIS OF ELASTIC CHARACTERISTICS STABILITY MADE FROM SAV-1 ALLOYS OF FUEL ELEMENTS AT THE WWR-SM REACTOR WITH ULTRASONIC METHOD

Brikulya E.Yu., Kalin B.A., Oleynikov I.V., Volkov N.V. 147
IDENTIFICATION METHOD OF EMISSION PEAKS FROM OXIDE FILM IN THE IR-RANGE WAVELENGTH

Cherepanov A. N. 148
TO THE QUESTION OF THE ANALYSIS OF EXPERIMENTAL SPECTRA

Izbaskhanova A. T., Kadyrzhanov K. K., Kenzhin E. A. 148
SAFETY ASSURANCE FOR RESEARCH OF RADIATION HEATING OF MATERIALS UNDER EXPOSURE IN IGR REACTOR CORE

Kulevoy T.V., Chalykh B.B., Kuybeda R.P., Grachev N.Yu., Aleev A.A., Nikitin A.A., Iskanderov N.A., Orlov N.N., Fertman A.D., Rogozhkin S.V. 150
IMITATION EXPERIMENTS FOR INVESTIGATION OF REACTOR MATERIALS RADIATION HARDNESS

Kulevoy T.V., Chalykh B.B., Kuybeda R.P., Aleev A.A., Nikitin A.A., Orlov N.N., Rogozhkin S.V. 151
EXPERIMENTAL CHANNEL COMMISSIONING AND FIRST EXPERIMENTS FOR MATERIAL IRRADIATION AT HEAVY ION RFQ IN ITEP

Lisitsyn V. M., Polisadova E.F., Valiev D.T. MODELLING OF PASSAGE OF OPTICAL SIGNALS THROUGH RE- CORDING SYSTEM IN THE ENVIRONMENT OF LabVIEW	152
Lisitsyn V. M., Tarasenko V.F., Polisadova E. F. , Baksht E. H., Valiev D. T., Burachenko A. G. , Lipatov E.I. PULSED CATHODOLUMINESCENCE OF MINERALS EXCITED BY NANOSECOND AND SUBNANOSECOND ELECTRON BEAMS	154
Sosnin E. A., Avtaeva S.V., Panarin V. A., Avdeev S. M. THE INTERRELATION BETWEEN THE THERMODYNAMIC AND OPTICAL PARAMETERS OF DBD-DRIVEN XECL-EXCILAMP: MODELING AND EXPERIMENT	155
Sosnin E. A., Panarin V. A., Pikulev A. A., Tarasenko V. F. STUDY OF ACOUSTIC VIBRATIONS OF DBD-DRIVEN PLANAR KRCL-EXCILAMP	156
Yakovlev A. N., Kostikov K. S., Martyshev N. V., Shepotenko N. A., Falkovich Yu. V. INSTITUTE OF HIGH TECHNOLOGY PHYSICS EXPERIENCE IN MASTERS OF ENGINEERING AND DOCTORAL TRAINING: THE PLATFORM FOR COOPERATION WITH RUSSIAN ACADEMY OF SCIENCES INSTITUTIONS IN THE DOMAIN OF MATERIAL SCIENCE AND PHYSICS OF HIGH ENERGY SYSTEMS	156
Yakovlev A. N., Kostikov K. S., Martyshev N. V., Shepotenko N. A., Falkovich Yu. V. RESEARCH WORK OF STUDENTS AS THE PLATFORM FOR DOCTORAL EDUCATION	158

***17th International Symposium on
High Current Electronics***

Intense electron and ion beams

Abdullin E. N., Morozov A.V. GENERATION OF ELECTRON BEAMS WITH CURRENT PULSE DURATION OF 10^{-5} S IN VACUUM DIODE WITH PLASMA ANODE	162
---	------------

Abdullin E. N., Morozov A.V. MODELING OF MAGNETIC FIELD OF VACUUM DIODE WITH RETURN CURRENT CONDUCTORS	163
Astrelin V.T., Burdakov A.V., Kandaurov I.V., Karpov I.E., Trunev Yu.A. CONCEPTUAL DESIGN AND NUMERICAL SIMULATION OF LONG-PULSED 1-kA ELECTRON BEAM SOURCE FOR OPEN MAGNETIC TRAPS	164
Egorov I.S., Remnev G.E., Kaikanov M. I., Lukonin E.I., Esipov V.S., Poloskov A.V., Kolokolov D.Yu. A REPETITIVE SOURCE OF PULSED ELECTRON BEAMS	165
Grigoryev S.V., Moskvina P.V., Teresov A.D. INVESTIGATION OF THE PLASMA EMITTER BASED ON THE REFLEX DISCHARGE WITH A CATHODE SPOT FOR INTENSE SUBMILLISECOND ELECTRON BEAM	166
Isakova Y.I., Pushkarev A.I., Khaylov I.P. FORMATION OF CHARGE – EXCHANGE NEUTRAL ATOMS IN A DIODE WITH PASSIVE ANODE	167
Kamenetskikh A.S., Gavrilov N.V. SELF-OSCILLATORY MODE OF ELECTRON BEAM GENERATION IN A SOURCE WITH A GRIDDED PLASMA CATHODE	168
Kandaurov I.V., Astrelin V.T., Avrorov A.P., Burdakov A.V., Bykov P.V., Derevyankin G.E., Ivanov A.A., Ivanov I.A., Kurkuchekov V.V., Polosatkin S.V., Rovenskikh A.F., Trunev Yu.A. HIGH POWER (10 MW), LONG PULSE MULTIAPERTURE ELECTRON BEAM INJECTOR WITH PLASMA EMITTER DESIGNED FOR BEAM-PLASMA EXPERIMENTS	169
Karlik K.V., Zyl'kova L.A., Ozur G.E. THE USE OF FERROMAGNETIC INSERTS FOR CONTROL OF THE ENERGY DENSITY PROFILE OF HIGH-CURRENT ELECTRON BEAM	170
Khailov I.P., Isakova Y.I., Pushkarev A.I. A COMPACT CALORIMETER BASED ON A MAGNETICALLY INSULATED FARADAY CUP FOR INTENSE ION BEAM DIAGNOSTIC	171
Kharlov A.V., Kovalchuk B.M., Kumpyak E.V., Tsoy N.V., Smorudo G.V. CAPACITOR BLOCKS FOR AIR INSULATED LTD STAGES	171

Kiziridi P.P., Ozur G.E. HIGH-CURRENT ELECTRON GUN WITH PLASMA ANODE BASED ON COMBINED DISCHARGE	172
Koryukina E.V., Koryukin V.I. MODELING OF THE CA STARK EFFECT OF THE THE KR^+ ION	173
Menshakov A.I., Gavrilov N.V. THERMOCHEMICAL SELF-HEATED HOLLOW CATHODE FROM A TITANIUM NITRIDE	175
Petrov A.V., Anan'in P.S., Bystritskii V., Yampolsky J., Isakov I.F., Karpov V.B., Matvienko V.M., Polkovnikova N.M., Sinebryukhov A.A., Surikov Yu.P., Usov Yu.P., Walters K. REPRATE ION BEAM ACCELERATOR WITH INTERMEDIATE LINEAR STEP-UP TRANSFORMER	176
Sorokin S.A. LOW-IMPEDANCE ROD-PINCH DIODES AS INTENSE X-RAY SOURCES	176
Stepanov A.V., Lopatin V.S., Remnev G.E. ION B_r – DIODE WITH THE ACTIVE ANODE	177
Uvarin V.V., Kuznetsov D.L., Lyubutin S.K., Slovikovskii B.G. COMPACT NANOSECOND ELECTRON BEAM SOURCE BASED ON 200 KV SOS GENERATOR	178
Vagin E.S., Grigoriev V.P., Ofitserov V.V. INVESTIGATION OF TRANSFER HIGH-CURRENT ELECTRON BEAM IN PLASMA CHANNEL	179
Volkov N.V., Kalin B.A., Krivobokov V.P. THE ION-BEAM INSTALLATION FOR FINISH TREATMENT OF DISPERSION FUEL CLADDINGS	180
Zvigintsev I.L., Grigoriev V.P. CHARGE NEUTRALIZATION AND RISE-UP PORTION EROSION OF LOW-ENERGY ELECTRON BEAM WHEN INJECTING INTO NEUTRAL GAS	181

Pinches plasma focus and capillary discharge

Artyomov A.P., Chaikovsky S.A., Fedunin A.V., Oreshkin V.I., Shljakhtun S.V., Lavrinovich I.V. THE WIRE EXPLOSION STAGE DURING X-PINCH SOFT X-RAY SOURCE FORMATION	182
---	------------

Contents

. Chaikovsky S.A., Kokshenev V.A., Labetsky A.Yu., Shishlov A.V. EFFICIENCY OF THE ENERGY DELIVERY FROM VACUUM MITL OF THE GIT-12 GENERATOR TO THE WIRE ARRAY PLACED IN THE WATER	183
Datsko I.M., Chaikovsky S.A., Labetskaya N.A., Oreshkin V.I., Chuvatin A.S. A LOAD CURRENT MULTIPLIER FOR THE TERAWATT-LEVEL MIG GENERATOR	184
d'Almeida T., Maury P., Grunenwald J., Zucchini F., Plouhinec D., Lassalle F., Loyen A., Morell A. FIRST RESULTS OF TUNGSTEN Z-PINCH WIRE-ARRAY LOADS ON THE MICRO-SECOND SPHINX GENERATOR	185
Labetskaya N.A., Oreshkin V.I., Chaikovsky S.A., Datsko I.M., Ratakhin N.A., Sukovatitsyn Y.A., Volkov E.N. EXPERIMENTAL STUDY OF SURFACE STABILITY OF CYLIN- DRICAL CONDUCTORS IN THE FAST RISING MEGAGAUSS MAGNETIC FIELD	186
Labetsky A.Yu., Kokshenev V.A., Shishlov A.V. DETERMINATION OF THE CURRENT DISTRIBUTION IN A PLANE SHEATH USING B-DOT PROBES	187
Loginov S.V. SOME PRINCIPAL ISSUES OF PLASMA OPENING SWITCHES OP- ERATION	187
Loginov S.V. EFFICIENCY OF MICROSECOND PLASMA OPENING SWITCHES	188
Nagayev K.A., Barakhvostov S.V., Bochkarev M.B., Volkov N.B. FEATURES OF THE PLASMA-CHANNEL FORMATION DURING THE VOLTAGE GENERATOR WITH THE 1-MV/NS-VOLTAGE- RISE-RATE DISCHARGE TO THE VACUUM COAXIAL LINE CON- TAINING MICROCONDUCTOR ENCLOSED GAP	188
Oreshkin V.I., Chaikovsky S.A., Labetskaya N.A., Datsko I.M. STABILITY OF NONLINEAR MAGNETIC FIELD DIFFUSION	189
Pinchuk M.E., Bogomaz A.A., Budin A.V., Rutberg Ph.G., Leks A.G., Svetova V.Yu., Losev S.Yu., Pozubenkov A.A. ENERGY DENSITY INCREASING IN CHANNEL OF SUPER-HIGH PRESSURE MEGAAMPERE DISCHARGE DUE TO RESONANCE OF DIFFERENT TYPE OSCILLATIONS OF THE CHANNEL	190

Shemyakin I.A., Korolev Yu.D., Landl N.V., Frants O.B. CURRENT PASSAGE MECHANISM IN A HIGH-CURRENT LOW-PRESSURE PULSED GLOW DISCHARGE	191
Shishlov A.V., Fursov F.I., Kovalchuk B.M., Kokshenev V.A., Kurmaev N.E., Labetsky A.Yu., Ratakhin N.A., Klir D., Cikhardt J., Kravarik J., Kubes P., Rezac K. DEUTERIUM GAS-PUFF DYNAMICS AND NEUTRON PRODUCTION IN EXPERIMENTS ON THE GIT-12 GENERATOR	191
Sorokin S.A. K-SHELL X-RAY AND NEUTRON EMISSION FROM A DOUBLE SHELL GAS-PUFF LINER	192
Svetova V.Yu., Rutberg Ph.G., Pinchuk M.E., Bogomaz A.A., Budin A.V., Leks A.G., Losev S.Yu., Pozubenkov A.A. HEATING OF HIGH-DENSITY HYDROGEN BY HIGH-CURRENT ARC RADIATION	193
Tkachenko S.I., Khattatov T.A., Romanova V.M., Mingaleev A.R., Baksht R.B., Oreshkin V.I., Shelkovenko T.A., Pikuz S.A. STUDY OF REGULAR STRIATIONS AND GAPS ACCIDENTALLY FORMED DURING WIRE EXPLOSION	194
Tkachenko S.I., Zhakhovsky V.V., Shelkovenko T.A., Pikuz S.A. DIFFERENT SCENARIOS OF FORMATION OF THE CORONA-CORE STRUCTURE DURING ALUMINUM WIRE EXPLOSION	195
Volkov N.B., Chingina E.A., Yalovets A.P. TWO-TEMPERATURE MODEL FOR THE SOLID METALS AT HIGH ENERGY DENSITIES	196

High power microwaves

Andreev Yu.A., Koshelev V.I., Romanchenko I.V., Rostov V.V., Sukhushin K.N. CONTROL OF HIGH-POWER ULTRAWIDEBAND RADIATION PULSE SPECTRUM	198
Arbuzov A.Yu., Avgustinovich V.A., Artemenko S.N., Kaminsky V.L., Novikov S.A. OPERATION OF TWO OVERSIZED CAVITIES IN MICROWAVE COMPRESSOR CONNECTED IN PARALLEL	199

Contents

Arteev M.S., Avgustinovich V.A., Artemenko S.N., Kaminsky V.L., Novikov S.A., Yushkov Yu.G. GASEOUS NITROGEN LASER IN SYSTEM OF MICROWAVE SWITCH TRIGGERING	200
Arteev M.S., Artemenko S.N., Yushkov Yu.G. THE COMMUTATION OF RESONANCE MICROWAVE COMPRES- SORS BY LASER RADIATION	200
Artemenko S.N., Avgustinovich V.A., Shlapakovskiy A. THE FORMATION OF A RESONANT MICROWAVE PULSE COM- PRESSOR WITH ADJUSTABLE PARAMETERS	201
Fedorov V.M., Ostashev V.Ye., Ul'yanov A.V. PATTERNS OF PEAK POWER AND ENERGY OF ULTRA- WIDEBAND PULSE RADIATION FROM APERTURE ANTENNAS	202
Igumnov V.S., Avgustinovich V.A., Artemenko S.N., Novikov S.A., Yushkov Yu.G. SIMULATION OF COMPRESSION IN THE CAVITY OF THE MI- CROWAVE PULSES WITH OUTPUT ENERGY OF THE OSCILLA- TIONS TRANSFORMATION	202
Karsli O., Yavas O., Dogan M. DESIGN OF L BAND 20 KW HIGH POWER SOLID STATE AMPLI- FIER FOR TARLA / TAC PROJECT	203
Klimov A.I., Vykhodtsev, P.V., Kovalchuk O.B. , Sinyakov A.N. CALORIMETER FOR MEASURING HIGH POWER MICROWAVE PULSE ENERGY	204
Klimov A.I., Rostov V.V. TEST MEASUREMENTS FOR THE TRANSMITTING ANTENNA OF A RELATIVISTIC BWO	205
Klimov A.I., Kovalchuk O.B., Sinyakov A.N. SPECTRAL MEASUREMENTS OF HIGH POWER MICROWAVE SUPERRADIATIVE PULSES	206
Klimov A.I., Kovalchuk O.B. TESTING OF THE TRANSMITTING ANTENNA OF A SUPERRADIATIVE BWO	208
Kornienko V.N., Cherepenin V.A. THE INFLUENCE OF THE TRANSVERSE DIMENSION OF MULTIWAVE CERENKOV OSCILLATOR ON THE SPATIAL STRUCTURE OF THE RADIATION FIELD	209

Contents

Koshelev V.I., Efremov A.M., Kovalchuk B.M., Plisko V.V. HIGH-POWER SOURCE OF ULTRAWIDEBAND RADIATION WITH WAVE BEAM STEERING	210
Koshelev V.I., Deichuly M.P. LINEAR POLARIZED RADIATION IN MULTIWAVE CHERENKOV GENERATOR	211
Marchenko A.L., Koval T.V. EXCITATION OF ELECTROMAGNETIC OSCILLATIONS OF THE LOWEST TYPES IN A FLAT-COAXIAL REFLEX TRIODE	212
Marchenko A.L., Koval T.V. INVESTIGATION OF THE INFLUENCE OF THE ANODE CURRENTMAGNETIC FIELD ON THEBEAM ELECTRONS MOVE- MENT IN REFLEX TRIODES	212
Nguyen M.T., Koval T.V., Zherlitsyn A.G., Kanaev G.G. STUDY OF ELECTRODYNAMIC AND RADIATION CHARACTER- ISTICS OF A COAXIAL AND A PLANAR-COAXIAL VIRCATOR	213
Nguyen M.T., Koval T.V., Zherlitsyn A.G., Kanaev G.G. EXCITATION OF TE_{11} MODE IN THE PLANAR-COAXIAL TRIODE WITH VIRTUAL CATHODE	213
Novikov S.A., Avgustinovich V.A., Artemenko S.N., Kaminsky V.L., Yushkov Yu.G. SINGLE CAVITY MICROWAVE COMPRESSOR WITH TWO PAR- ALLEL OUTPUTS	214
Romanchenko I.V., Rostov V.V., Klimov A.I., Kurkan I.K., Gunin A.V., Sukhushin K.N., Plisko V.V., Sinyakov A.N., Kutenkov V.O. HIGH POWER 4 CHANNEL CYROMAGNETIC RF SOURCE	215
Rukin S.N., Lyubutin S.K., Slovikovsky B.G., Tsyranov S.N. HIGH POWER MICROWAVE GENERATION IN SEMICONDUCTOR DIODE	215
Samoylenko G.M., Artemenko S.N., Kaminsky V.L. THE COMPRESSION OF MICROWAVE PULSES IN SUPERCON- DUCTING RESONATORS	216
Tsygankov R.V., Konev V.Y., Totmeninov E.M., Rostov V.V., Pegel I.V., Kitsanov S.A., Klimov A.I. COAXIAL MODERATELY RELATIVISTIC L-BAND BACKWARD WAVE OSCILLATOR	217

**Zhukov A.A., Avgustinovich V.A., Artemenko S.A., Kaminsky V.L.,
Novikov S.A.**
SWITCHING OF H11-MODE WAVE OF 0.5 GW POWER IN CIRCULAR WAVEGUIDE 217

Pulsed power technology

**Artyomov A.P., Bykova M.G., Chaikovskiy S.A., Erfort A.A.,
Feduschak V.F., Fedunin A.V., Lavrinovich I. V., Oreshkin V.I.,
Ratakhin N.A., Rousskikh A.G., Zhigalin A.S., Zharova N.V.**
THE LOW SCALE SOFT X-RAY NANOSECOND PULSE
RADIOGRAPH BASED ON THE X-PINCH 219

Egorov O.G.
POWERFUL TWO-STAGE DC BREAKER 220

Egorov O.G.
THE GENERATOR OF HIGH-POWER NANOSECOND PULSES ON
THE BASIS OF INDUCTIVE ENERGY STORAGE 221

Gugin P.P., Bokhan P.A., Lavrukhin M.A., Zakrevskiy D.E.
SWITCHING OF HIGH-VOLTAGE PULSES WITH
SUBNANOSECOND PULSE FRONTS USING AN OPEN DISCHARGE
IN A COAXIAL AND PLANAR GEOMETRY 223

Guo Fan, Zou Wenkang, Chen Lin
CIRCUIT SIMULATION OF MAGNETICALLY-INSULATED IN-
DUCTION VOLTAGE ADDER 224

**Gusev A.I., Slovikovskiy B.G., Lyubutin S.K., Rukin S.N., Tsyranov
S.N.**
ULTRASHORT VOLTAGE RISE TIME FORMATION BY SEMICON-
DUCTOR SHARPENERS 225

Gusev A.I., Ponomarev A.V., Rukin S.N.
COMPACT HIGH-FREQUENCY SOLID-STATE GENERATOR WITH
SUBNANOSECOND VOLTAGE RISE TIME 225

Hemmert D.J., Mankowski J.M., Altgilbers L.L.
A FERROELECTRIC EXPLOSIVE GENERATOR COUPLED TO A
COMMON MICROWAVE OVEN MAGNETRON 226

Hojatzadeh K.
A SIMPLE CLADDING TECHNIQUE FOR CONSTRUCTING FAST
CVD. A Prototype 50 kV/ 2.5 GHz/ 70 dB/ 5 ns/ 50 Ω Loaded CVD 227

Hojatzadeh K. UWB PULSE COMPRESSORS BASED ON THE OVERVOLTING CHARGE TECHNIQUE	228
Hongwei Liu, Jianqiang Yuan, Jinfeng Liu, Hongtao Li, Weiping Xie QUASI-LINEAR MODE OF HIGH POWER GAAS PCSSS	228
Kablambaev B.A., Ratakhin N.A. A SQUARE VOLTAGE PULSE FORMER WITH A PEAK VALUE UP TO 500 KV AND 200 NS DURATION	229
Kharlov A.V., Kovalchuk B.M., Kumpyak E.V., Sinebryukhov V.A., Kiselev V.N. PULSED GENERATORS FOR DYNAMIC FRAGMENTATION OF ROCKS	230
Kim A.A., Sinebryukhov V.A., Volkov S.N., Kondratiev S.S., Alexeenko V.M., Bayol F., Demol G. PULSE SHAPING IN SQUARE PULSE LTD	231
Kokshenev V.A., Fursov F.I., Kurmaev N.E., Labetsky A.Yu., Semenov A.P., Shishlov A.V. A TERA-WATT-LEVEL POWER AMPLIFIER WITH A LOAD CUR- RENT MULTIPLIER LOCATED UPSTREAM OF THE POS	232
Konev V.Y., Klimov A.I. PHASE FIXATION OF POWER NANOSECOND GUNN OSCILLA- TORS	233
Krastelev E.G., Stepnov V.V. NANOSECOND PULSED POWER GENERATOR FOR SELECTIVE DISINTEGRATION OF MINERAL QUARTZ	233
Kurkan I.K., Bykov N.M., Gunin A.V., Rostov V.V. HIGH-VOLTAGE SPARK GAP SWITCH WITH SUBNANOSECOND RISE TIME	234
Lavrinovich A.V., Kachalkov A.A. AN UNTRIGGERED GAS PULSE SWITCH WITH IMPROVED OP- ERATION (ACTUATION) STABILITY	235
Liu Yu, Chen Lin, Zhou Liangji, Zou Wenkang, Dai Yingmin EXPERIMENTAL INVESTIGATION ON ELECTRODE EROSION AND INSULATION RECOVERY OF HIGH CURRENT GAS SPARK GAP	236
Loyen A., Lassalle F., Roques B., Chanconie T., Bayol F. CONCEPTUAL DESIGN OF A NEW MICROSECOND LTD STAGE FOR AN UPGRADE OF THE SPHINX Z-PINCH DRIVER	236

Contents

Oreshkin V.I., Kim A.A., Glazov L.G. LTD EFFICIENCY FOR Z-PINCH LOADS	237
Petin V.K., Chertov A.A., Shljakhtun S.V. HARD X-RAY SOURCES BASED ON OF HIGH-CURRENT ACCELERATORS	238
Ponomarev A.V., Lipchak D.A. HIGH FREQUENCY GENERATOR BASED ON THE SHOCK-EXCITED OSCILLATOR CIRCUIT	239
Rukin S.N., Lyubutin S.K., Slovikovsky B.G., Tsyranov S.N. OPERATION OF A SEMICONDUCTOR OPENING SWITCH AT ULTRAHIGH CURRENT DENSITIES	239
Rukin S.N., Gusev A.I., Pedos M.S., Ponomarev A.V., Timoshenkov S.P., Tsyranov S.N. SOLID STATE HIGH-POWER GENERATOR BASED ON DOUBLE FORMING LINE AND SEMICONDUCTOR OPENING SWITCH	240
Scherbinin S.V., Balezin M.E., Sokovnin S.Yu., Surovtzev A.E. THE VISUALIZATION AND ASSESSMENT OF THE PULSED ELECTRON BEAM CURRENT DENSITY DISTRIBUTION	241
Sharypov K.A., Ulmaskulov M.R., Shpak V.G., Shunailov S.A., Yalandin M.I. INCREASING STABILITY OF HIGH-VOLTAGE SUBNANOSECOND PULSE PARAMETERS	241
Sharypov K. A., Shunailov S. A., Shpak V. G., Ulmaskulov M. R., Yalandin M. I. HIGH-VOLTAGE LOW-DISTORTION REFLECTOMETR BASED ON TWO VOLTAGE DIVIDERS WITH COUPLED LINES	252
Sharypov K.A., Ulmaskulov M.R., Shpak V.G., Shunailov S.A., Yalandin M.I., Rostov V.V., Rukin S.N. HIGH-VOLTAGE FERRITE SHARPENING LINE WITH CONTROLLED DELAY TIME	243
Shljakhtun S.V., Kachalkov A.A., Lavrinovich A.V., Petin V.K. A COMBINED SHARPENING-CHOPPING SWITCH WITH OPERATING VOLTAGE ABOUT 1 MV	244
Struve K.W., Mazarakis M.G., Savage M.E. LTD DESIGN BASED ON PARAMETERS OF AVAILABLE SWITCHES	245

Tao Shao, Hui Jiang, Cheng Zhang, Xueke Che, Wenfeng Li, Ping Yan NANOSECOND-PULSE SURFACE DIELECTRIC BARRIER DISCHARGE IN OPEN AIR	246
Zhang Le, Wei Bing, Zou Wenkang INSULATOR SUPPORT OF COAXIAL MAGNETICALLY-INSULATED TRANSMISSION LINE	247
Zherlitsyn A.A., Kovalchuk B.M., Pedin N.N. GENERATION OF A FOCUSED ELECTRON BEAM IN A PLASMA-FILLED DIODE	247
Zherlitsyn A.A., Kovalchuk B.M., Pedin N.N. A COMPACT AIR INSULATED GENERATOR FOR E-BEAM DIODE	248
Zherlitsyn A.A., Kovalchuk B.M., Orlovskii V.M., Pedin N.N. PLASMA-FILLED DIODE WITH USING LASER PRODUCED PLASMA	248
Zhuravlev M.V., Slobodyan M.S., Shubin B.G. THE SYSTEM FOR SPARK CLEANING OF LOW CARBON STEEL	249
Zhuravlev M.V., Slobodyan M.S., Shubin B.G. THE SYSTEM FOR ATMOSPHERE HF SPACE DISCHARGE	249

Pulsed power applications

Arantchouk L., Brelet Y., Houard A., André Y-B, Prade B., Carbonnel J., Mysyrowicz A. GUIDING 1-M SCALE DISCHARGE CREATED BY A TESLA GENERATOR TRIGGERED WITH FEMTOSECOND LASER FILAMENT IN AIR	250
Arantchouk L., Houard A., Brelet Y., Forestier B., Carbonnel J., Larour J., Mysyrowicz A. LOW JITTER, HIGH CURRENT SPARK GAP OPERATING WITH AIR AT NORMAL PRESSURE	251
Beketov I.V., Bagazeev A.V., Medvedev A.I., Ivanov V.V., Safronov A.P., Timoshenkova O.R. COAXIAL PULSED DISCHARGE GUN FOR SYNTHESIZING NANOPARTICLES	252
Buldakov M.A., Klimov I.A., Kutenkov O.P., Bolshakov M.A., Cherdyntseva N.V., Rostov V.V. POTENTIAL APPLICATION OF NANOSECOND PULSED X-RAY IN MEDICINE	253

Chengyan Ren, Jue Wang, Ping Yan, Cheng Zhang, Tao Shao, Jiayu Xu, Yuanqing Liu, Huijuan Ran, Tao Wang, Wenfeng Li EXPERIMENT STUDY ON HIGH VOLTAGE DISCHARGES AND SOUND CHARACTERISTICS UNDER ATMOSPHERIC CONDI- TIONS	254
Cheng Zhang, Huijuan Ran, Jue Wang, Tao Wang, Tao Shao, Ping Yan DISCHARGE CHARACTERISTIC IN UNIFORM ELECTRIC-FIELD SF ₆ GAP UNDER REPETITIVE NANOSECOND PULSES	255
Dolinovskaya R.V., Rutberg Ph.G., Kolikov V.A., Pinchuk M.E., Leks A.G., Snetov V.N., Stogov A.Yu. SHOCK WAVES AND BUBBLE EXPANSION IN LOW ENERGY PULSED ELECTRIC DISCHARGE IN WATER	256
Dudarev V.V., Konovalov I.N., Losev V.F., Panchenko Yu.N., Pavlinsky A.V., Puchikin A.V. DISCHARGE TEA CO ₂ LASER WITH SHORT PULSE DURATION	257
Filatov I.E., Nikiforov S.A., Surkov Yu.S., Uvarin V.V. ACTION OF HIGH-ENERGY ELECTRON BEAM ON POLYCHLO- RINATED COMPOUNDS ADSORBED ON SURFACES	258
Ivanov N.A., Kuznetsova N.S., Lopatin V.V., Yudin A.S., Golovanevskiy V. SPLITTING OFF CONCRETE LUMPS BY BOREHOLE ELECTROBLAST	259
Kaikanov M.I., Remnev G.E., Egorov I.S. AN EFFECT OF HIGH CURRENT ELECTRON BEAM OF NANO- SECOND DURATION ON N-DECANE	260
Kholodnaya G.E., Sazonov R.V., Ponomarev D.V., Remnev G.E. PLASMA-CHEMICAL SULPHUR RECOVERY UNDER ACTION OF PULSE ELECTRON BEAM ON SULPHUR HEXAFLUORIDE	261
Knyazeva I.R., Bolshakov M.A., Ivanov V.V., Zharkova L.P., Kereya A.V., Kutenkov O.P., Rostov V.V. THE RESPONSES OF MICE LIVER MITOCHONDRIA TO THE REPETITIVE PULSED MICROWAVE AND X-RAY	262
Kolokolov D.Yu., Egorov I.S., Kaikanov M.I., Merinova L.R., Remnev G.E., Sazonov R.V., Stepanov A.V., Voyno D.A., Maslov A.S., Siarg B.A. TREATMENT OF INDUSTRIAL AND HOUSEHOLD WASTE WATER WITH THE PULSE ELECTRON ACCELERATOR-BASED SETUP	263

Contents

Krastelev E.G. DEVELOPMENT OF PULSED POWER EQUIPMENT FOR TECHNOLOGICAL APPLICATION IN PRODUCTION OF PURE QUARTZ	264
Kuznetsov D.L., Surkov Yu.S. , Uvarin V.V. LIMITATION OF AVERAGE POWER OF INFRARED LASING IN AR-XE MIXTURE DURING REP-RATED ELECTROIONIZATION PUMPING	265
Kuznetsov D.L., Filatov I.E., Surkov Yu.S. PULSED ELECTROPHYSICAL METHODS OF TOXIC IMPURITIES CONVERSION IN AIR AND ON THE BORDER OF GAS AND ADSORBENT	266
Kuznetsova N.S., Lopatin V.V., Burkin V.V., Golovanevskiy V.A., Stefanov Yu.P BLAST-HOLE ELECTRO FRACTURE OF OVERSIZE ROCKS	268
Lavrinovich I.V., Zharova N.V, Bykova M.G NANOSECOND CURRENT GENERATOR BASED ON A SINGLE HCEIcap 80-0.25 CAPACITOR-SWITCH ASSEMBLY	269
Losev V.F., Alekseev S.V., Ivanov N.G., Kovalchuk B.M., Mesyats G.A., Mikheev L.D., Panchenko Yu.N., Ratakhin N.A. HYBRID FEMTOSECOND LASER SYSTEM ON BASE OF PHOTOCHEMICALLY DRIVEN XEF(C-A) AMPLIFIER	269
Maslennikov S.P., Krastelev E.G., Shcolnikov E.Ya. RESEARCH OF ATMOSPHERIC PULSED-PERIODICAL DIFFUSE DISCHARGE	271
Panchenko Yu.N., Andreev M.V., Dudarev V.V., Ivanov N.G., Losev V.F.,Pavlinsky A.V., Puchikin A.V. COMPACT DISCHARGE KrF LASER SYSTEM WITH HIGH QUALITY BEAM	272
Ponomarev D.V., Sazonov R.V., Kholodnaya G.E., Remnev G.E. PULSE PLASMA-CHEMICAL SYNTHESIS OF AMORPHOUS PHASE OF NANOSIZE TITANIUM DIOXIDE	273
Sazonov R.V., Ponomarev D.V., Kholodnaya G.E., Remnev G.E. PULSE PLASMA-CHEMICAL SYNTHESIS OF NANOSIZED SILICON SIOXIDE FROM METAL-ORGANIC PRECURSOR – TETRAETHOXYSILANE	274
Shverikas A.A., Balezin M.E., Scherbinin S.V., Sokovnin S.Y. X-RAYS NANOSECOND BLOOD IRRADIATOR	274
Sokovnin S.Y., Balezin M.E., Scherbinin S.V. ACCELERATOR URT-1M FOR RADIATION TECHNOLOGIES	275

Sokovnin S.Y., Balezin M.E., Lisenkov V.V., Bogun A.
RESEARCH OF ULTRA-VIOLET RADIATION THE NANOSECOND
GAS DISCHARGE INFLUENCE ON PATHOGENIC MICROORGAN-
ISMS 276

Uvarin V.V., Kuznetsov D.L., Filatov I.E.
CONVERSION OF CH₄-CO₂ MIXTURE UNDER THE INFLUENCE OF
NANOSECOND ELECTRON BEAM AND GAS DISCHARGE 277

Discharges with runaway electrons

Bokhan P.A., Gugin P.P., Lavrukhin M. A., Zakrevsky D. E.
INSTABILITIES OF HIGH-CURRENT OPEN DISCHARGES AND
THEIR CRITICAL PARAMETERS 278

**Cheng Zhang, Tao Shao, Tarasenko V.F., Ma Hao, Evgeni Kh. Baksht
Ping Yan, Shutko Yu.V.**
X-RAY EMISSION FROM A NANOSECOND-PULSE DISCHARGE IN
AN INHOMOGENEOUS ELECTRIC FIELD AT ATMOSPHERIC
PRESSURE 278

Erofeev M.V., Baksht E.Kh., Tarasenko V.F., Shutko Yu.V.
RUNAWAY ELECTRON BEAM GENERATION IN HELIUM AND
AIR AT NANOSECOND DISCHARGE IN NONUNIFORM ELECTRIC
FIELD AT FREQUENCY UP TO 1000 Hz 279

Erofeev M.V., Schitz D.V., Skakun V.S., Tarasenko V.F.
VUV AR2-EXILAMP OF ONE BARRIER DISCHARGE 280

**Kozyrev A.V., Baksht E.H., Kostyrya I.D., Rybka D.V., Tarasenko
V.F.**
GENERATION OF FAST ELECTRONS AT ATMOSPHERIC PRES-
SURE AIR BREAKDOWN IN GAP WITH COMBINED PLANE-GRID
CATHODE 281

Lavrukhin M.A., Bokhan P.A., Gugin P.P., Zakrevsky D.E.
GENERATION OF INTENSIVE ELECTRON BEAMS IN AN OPEN
DISCHARGE WITH A PLANAR GEOMETRY 282

Lisenkov V. V., Osipov V. V.
NUMERICAL MODELING OF GENERATION OF FAST ELECTRON
BEAMS IN SUBNANOSECOND GAS DISCHARGE 283

Lomaev M.I., Sorokin D.A., Tarasenko V.F.
NARROWBAND RADIATION IN VUV SPECTRAL REGION OF BI-
NARY MIXTURES ARGON (HELIUM) – XENON PUMPED WITH
HIGH-VOLTAGE NANOSECOND DISCHARGE 283

Lomaev M.I., Kostyrya I.D., Rybka D.V., Tarasenko V.F. PULSE CORONA AND DIFFUSE DISCHARGES WITH RUNAWAY ELECTRONS IN ATMOSPHERIC PRESSURED AIR	284
Oreshkin E.V., Barenholts S.A., Chaikovskiy S.A., Oreshkin V.I. SIMULATION OF THE RUNAWAY ELECTRON BEAM FORMED IN A DISCHARGE AT ATMOSPHERIC PRESSURE	285
Reutova A.G., Shunailov S.A., Shpak V.G., Yalandin M.I., Mesyats G.A. PICOSECOND PROCESSES AT THE DELAY STAGE OF PULSE BREAKDOWN IN OVERVOLTAGE ATMOSPHERIC GAP	286
Rybka D.V., Tarasenko V.F., Baksht E.Kh., Burachenko A.G., Kostyrya I.D., Lomaev M.I. GENERATION AND MEASUREMENT OF SUPERSHORT AVALAN- CHE ELECTRON BEAMS IN ATMOSPHERIC PRESSURE AIR	287
Rybka D.V., Evtushenko G.S., Kozhevnikov V.Yu., Kostyrya I.D., Kozyrev A.V., Tarasenko V.F., Trigub M.V. PULSE CORONA DISCHARGE IN ATMOSPHERIC PRESSURED AIR	288
Shklyayev V.A., Belomyttsev S.Ya., Ryzhov V.V. NUMERICAL MODELING OF RUNAWAY ELECTRON BEAM FORMATION UNDER DEVELOPMENTAL GROWTH OF BREAK- DOWN OF OVERSTRAINED AIR GAP	289
Shklyayev V.A., Lisenkov V.V., Ryzhov V.V. NUMERICAL SIMULATION OF FAST ELECTRONS GENERATION IN ATMOSPHERIC PRESSURE INHOMOGENEOUS GAS MEDIA	289
Tao Shao, Cheng Zhang, Ping Yan DIFFUSE DISCHARGE PRODUCED BY REPETITIVE NANOSEC- OND PULSES IN OPEN AIR	290
Tao Shao, Rybka D.V., Tarasenko V.F., Cheng Zhang, Kozyrev A.V., Kostyrya I.D., Ping Yan, Kozhevnikov V.Yu. NANOSECOND CORONA DISCHARGE IN ATMOSPHERIC PRES- SURE AIR: RUNAWAY ELECTRONS AND X-RAYS	291
Tarasenko V. F. GENERATION OF RUNAWAY ELECTRONS AND X-RAYS IN DIF- FUZE DISCHARGES IN AN INHOMOGENEOUS ELECTRIC FIELD	292
Tarasenko V.F., Baksht E.Kh., Erofeev M.V., Lomaev M.I., Sorokin D.A., Shutko Yu.V. SPARK DISCHARGE FORMATION IN AN INHOMOGENEOUS ELECTRIC FIELD	293

**Tarasenko V.F., Baksht E.Kh., Burachenko A.G., Kozhevnikov V.Yu.,
Kozyrev A.V., Kostyrya I.D.**
SPECTRUM OF RUNAWAY ELECTRONS IN ATMOSPHERIC PRES-
SURE AIR DURING SUBNANOSECOND BREAKDOWN

294

*11th International Conference
on Modification of Materials with Particle Beams and
Plasma Flows*

Beam and plasma sources

- Alexandrov A.F., Kralkina E.A., Pavlov V.B., Petrov A.K., Vavilin
K.V.**
ADVANCED SOURCES FOR PLASMA AND ION-BEAM SURFACE
MODIFICATION TECHNOLOGIES 297
- Anshakov A. S., Urbakh E.K., Volokitin O.G., Urbakh A.E.,
Cherednichenko V.S.**
GENERATION OF ARK PLASMA FOR MATERIAL PROCESSING 298
- Baisanov O.A., Spivak-Lavrov I.F., Imangazina A.Zh., Doskeev G.A.**
MULTI-TURN TIME-OF-FLIGHT MASS SPECTROMETERS ON THE
BASIS OF THE CYLINDRICAL ELECTRIC SECTORS 299
- Berlin E.V., Grigoriev V.U., Shchelkanov I.A.**
ADVANCED ICP PLASMA SOURCE FOR HIGH DENSITY PLASMA
GENERATION 300
- Borisov D.P., Koval N.N., Korotaev A.D., Kuznetsov V.M., Romanov
V.Ya., Terekhov P.A., Chulkov E.V.**
EFFECTIVE VOLUMINOUS PLASMA ARC SOURCES IN TECHNO-
LOGICAL VACUUM-PLASMA SETUPS 302
- Denisov V.V., Shugurov V.V., Kalushevich A.A., Surmenev R.A.,
Surmeneva M.A., Ivanova A.A., Grubova I. Yu., Pichugin V.F.**
AUTOMATED SETUP OF HF MAGNETRON DEPOSITION OF BIO-
COMPATIBLE COATINGS 302
- Emlin D. R., Plotnikov S. A., Gavrilov N. V., Trachtenberg I. S.,
Khatmullin I. G.**
SCALING OF DLC CHEMICAL VAPOR DEPOSITION METHOD
WITH THE USE OF PLASMA CATHODE 303

Contents

Engelko V. I., Kovalev V. G., Tkachenko K. I., Pavlov E. P., Petukhov A. A., Shchegolikhin N. P. ELECTRON BEAM FACILITY FOR IMPROVMENT OF CORROSION RESISTANCE OF FUEL ELEMENT CLADDINGS	304
Gushenets V. I., Bugaev A. S., Oks E. M., Hershcovitch A., Kulevoy T. V. GASEOUS PHOSPHOROUS SOURCE FOR GENERATION OF MOLECULAR PHOSPHOROUS ION BEAMS FOR ION IMPLANTATION	305
Kalushevich A.A., Shugurov V.V., Koval N.N., Denisov V.V., Yakovlev V.V. AUTOMATIC VACUUM ION-PLASMA SETUP	306
Klimov A. S., Zenin A.A., Kazakov A.V., Burdovitsin V.A., Oks E.M. FEATURES OF THE FUNCTIONING PLASMA ELECTRON SOURCE BASED ON DISCHARGE WITH HOLLOW CATHODE AT HIGH PRESSURES	307
Korzhenko D.V., Krivobokov V. P., Yanin S. N. MODEL OF THE ELECTRIC DISCHARGE IN THE CROSSED ELECTRIC AND MAGNETIC FIELDS	307
Kotov D., Yasunas A. THE INFLUENCE OF ANTENNA SYSTEM CONFIGURATION ON THE DISCHARGE PARAMETERS OF THE INDUCTIVELY-COUPLED PLASMA SOURCE	308
Le Huy Dung, Koval T.V. INVESTIGATION OF THE INFLUENCE OF GUIDING MAGNETIC FIELD AND MAGNETIC FIELD OF THE BUS-BARS ON LOW-ENERGY ELECTRON BEAM DENSITY DISTRIBUTION	309
Le Huy Dung, Koval T.V. INVESTIGATION OF INFLUENCE OF THE PLASMA CHANNEL INHOMOGENEITY ON CURRENT-PASSAGE OF THE LOW-ENERGY HIGH-CURRENT ELECTRON BEAM	310
Lopatin I.V., Koval N.N., Kovalsky S.S., Schanin., P.M. STUDY OF PLASMA PARAMETERS OF NON-SELF SUSTAINED ARC DISCHARGE OF "PINK" PLAZMOGENERATOR	311
Martens V. Ya., Moiseev, S. V. DISTRIBUTIONS OF ELECTRIC POTENTIAL AND PLASMA CONCENTRATION IN THE ANODE REGION OF A LOW PRESSURE GAS DISCHARGE	312

Melnik Yu. A., Bolbukov V. P., Grigoriev S. N., Metel A. S. BEAM-ASSISTED DEPOSITION USING A SOURCE OF METAL VA- POR MIXED WITH FAST GAS MOLECULES	312
Metel A. S., Melnik Yu. A. PULSED ELECTRON GUNS ON THE BASE OF GLOW DISCHARGE WITH ELECTROSTATIC ELECTRON CONFINEMENT	313
Metel A. S. PLASMA IMMERSION BROAD BEAM SOURCES OF FAST ATOMS AND MOLECULES	315
Pavlov E P., Engelko V I., Shulov V A., Novikov A S., Tkachenko K I., Shchegolikhin N P., Kovalev, V G. Petukhov. A A., Beruchev N G., Pavlenko A.V., Chumichev V A., Baev V M., Daniltsev A N., Demidov V.L., Latmanizova M. A., Cherepanov Yu G., Makarova T. N. INDUSTRIAL ELECTRON BEAM FACILITY FOR MODIFICATION OF GAS TURBINE ENGINE BLADES	316
Rabotkin S.V., Sochugov N.S. , Kovsharov N.F. , Pugovkin M.M. INSTALLATION FOR MAGNETRON SPUTTERING OF MULTI- LAYER LOW-EMISSION COATINGS ON A POLYMER ROLL FILM	317
Ryabchikov A. I., Sivin D. O., Bumagina A. I., BEHAVIOR OF MACROPARTICLES NEAR AND ON A SUBSTRATE IMMERSED IN A VACUUM ARC PLASMA AT NEGATIVE HIGH- FREQUENCY SHORT-PULSED BIASING	317
A.I. Ryabchikov, Sivin D.O., Bumagina A.I. INVESTIGATION OF BEHAVIOUR OF THE VACUUM ARC MICRODROPLETS NEAR AND ON THE SURFACE OF THE PO- TENTIAL ELECTRODE DURING SHORT-PULSED HIGH- FREQUENCY PLASMA-IMMERSION ION IMPLANTATION	318
Shandrikov M.V., Tyunkov A.V., Vizir A.V., Yushkov G. Yu., E. Oks E. M. MULTIFUNCTIONAL PLASMA SOURCE WITH HIGH LIFETIME TWO-LAYER ELECTRON EMITTER	318
Shemyakin I. A., Korolev Yu. D., Frants O. B., Landl N. V., Kasyanov V. S., Bolotov A. V. and Geiman V. G. INVESTIGATION OF NON STEADY STATE LOW-CURRENT DISCHARGES FOR DIELECTRIC ADHESION INCREASING	319
Shugurov V.V., Kalushevich A.A., Denisov V.V., Yakovlev V.V. PLASMA GENERATION COMPLEX FOR EXTENDED DETAILS TREATMENT	320

Sivin D. O., Ryabchikov A. I., Bumagina A. I., Struts V. K. MECHANISMS AND REGULARITIES OF THE VACUUM ARC MACROPARTICLES BEHAVIOR NEAR AND ON A SUBSTRATE, IMMERSED IN PLASMA	321
Spivak-Lavrov I. F., Baisanov O. A. SIMULATION OF THE MAGNETIC TRAP BASED ON MAGNETIC FIELDS WITH AXIS OF SYMMETRY	321
Stepanov I. B., Ryabchikov A. I., Sivin D. O., Bumagin A. I. APPLICATION OF HIGH-FREQUENCY SHORT-PULSED PLASMA- IMMERSION ION IMPLANTATION OR DEPOSITION METHOD FOR DIELECTRIC MATERIALS PROCESSING USING GAS, METAL AND GAS - METAL PLASMA	323
Uvarov A. A., Alexandrov S. E. MODELING OF A SHIELDED INDUCTIVELY COUPLED PLASMA SOURCE FOR ITS DESIGN OPTIMIZATION	323
Yushkov Yu. G., Medovnik A. V., Oks E. M., V. A. Burdovitsin V. A. POTENTIAL OF CERAMICS SURFACE AT PULSE ELECTRON IM- PACT	324
Zherlitsyn A. G., Shiyan V. P., Kositsyn V. S. EXPERIMENTAL STUDY ON A MICROWAVE PLASMATRON WITH A HYDROCARBON-CONTAINING PLASMA-FORMING MEDIUM	325
Zhmurikov E. I., Stankus S. V., Yatsuk O. S., Tecchio L. B. THERMAL EXPANSION OF ARTIFICIAL GRAPHITES IN THE TEMPERATURE RANGE OF 293-1650K	326
Zimin V. P. CONDITION BURNING FOR LAYER OF PLASMA CESIUM ARC WITH RECOMBINATION	327

Fundamentals of modification processes

Alikin D. O., Shur V. Ya., Negashev S. A., Pryakhina V. I., Ievlev A. V., Zelenovskiy P. S., Dolbilov M. A., Gavrillov N. V. INFLUENCE OF THE LOW ENERGY ION IRRADIATION ON THE CONDUCTIVITY AND DOMAIN STRUCTURE EVOLUTION IN LiNbO_3	329
Bakin E. I., Krasnikov V. S., A. Yalovets A. P. MODELING OF RESIDUAL STRESS FORMATION IN METALLS AFTER IRRADIATION BY INTENSIVE ENERGY FLOWS	330

Bleykher G.A., Krivobokov., V.P. SOLID SURFACE EROSION PROPERTIES UNDER THE ACTION OF POWERFUL CHARGED PARTICLE BEAMS	331
Bytzenko O.A., Shulov V.A., Gromov A.N., Teryaev D. A., Engelko V. I., Tkachenko K.I. THE INFLUENCE OF RELAXATION PROCESSES ON EFFECTIVE- NESS OF PARTS SURFACE TREATMENT WITH INTENSE PULSED ELECTRON BEAMS	332
Dasheev D.E., Smirnyagina N.N. FEATURES OF THE PROCESS OF SELF-PROPAGATING HIGH- TEMPERATURE SYNTHESIS, A STRUCTURE AND STRONG PROPERTIES OF BORIDES IRON LAYERS ON THE CARBONA- CEOUS STEEL 3, GENERATED UNDER A POWERFUL ELECTRON BEAM IN VACUUM	333
Ilina E. S., Knyazeva A. G., Demidov V. N. MODELING OF INITIAL STAGE OF ION IMPLANTATION PRO- CESS. ISOTHERMAL APPROXIMATION	334
Krasnikov V. S., Mayer A. E. DISLOCATION DENSITY AND MICROHARDNESS CHANGE IN SURFACE LAYER OF IRON TARGET UNDER ION- AND ELEC- TRON-BEAM TREATMENT: NUMERICAL INVESTIGATION	335
Kul'ment'ev A.I. THEORETICAL DESCRIPTION OF MULTIPLE SCATTERING PRO- CESSES IN THE ION BEAM BASED METHODS	336
Leyvi A.Ya., Zotova M. Yu., Cherenda N.N., Uglov V.V., Yalovets A.P. MECHANISMS OF METAL SURFACE MODIFICATION UNDER PROCESSING BY COMPRESSION PLASMA FLOWS	337
Markov A. B., Dudarev E.F., Kashin O.A., A. Mayer A. E., Yakovlev E. V. Tabachenko A. N. DEFORMATION BEHAVIOR AND SPALL FRACTURE OF Cu-Al-Ni ALLOYS WITH SUBMICROCRYSTALLINE AND COARSE-GRAIN STRUCTURE IRRADIATED WITH A NANOSECOND RELATIV- ISTIC HIGH-CURRENT ELECTRON BEAM	338
Petukhou Yu. A., Kvasov N.T., Uglov V.V., Astashynski V.M, Kuzmitski A.M. PHASE TRANSFORMATIONS IN BINARY "METAL-SILICON" SYSTEMS UNDER THE ACTION OF DENSE COMPRESSION PLASMA	339

Petukhou Yu. A., Koval N.N., Ivanov Yu.F., Uglov V.V., Teresov A.D., Kalin A.V. ELEMENTAL COMPOSITION OF SURFACE LAYERS OF “METAL-ON-SILICON” SYSTEMS TREATED BY LOW-ENERGY HIGH-CURRENT ELECTRON BEAMS	340
Pogorelko V. V., Yalovets A. P. CALCULATION OF STRESS FIELDS IN COMPOSITE AT INFLUENCE OF THE HIGH-CURRENT ELECTRONIC BEAM	342
Punanov I. F., Emlin R. V., Kulikov V. D., Cholakh S. O. MEASUREMENT OF PRE-BREAKDOWN CURRENT IN ALKALI-HALIDE MONOCRYSTALS UNDER NANOSECOND PULSED VOLTAGE CONDITIONS	343
Shepel D. A., Markov A. B. PREDICTION OF TEMPERATURE FIELDS IN STAINLESS STEEL AND NiTi TARGETS CONTAINING INCLUSIONS IRRADIATED BY A LOW-ENERGY HIGH CURRENT PULSED ELECTRON BEAM	343
Smirnyagina N.N., Khaltanova V.M., Kim T.B., A.S.Milonov THERMODYNAMIC MODELING OF BORIDES AND CARBIDES TUNGSTEN FORMATION, SELF-EXTENDING HIGH-TEMPERATURE SYNTHESIS, STRUCTURE AND PHASE COMPOSITION OF W ₂ B ₅ AND WC LAYERS, GENERATED AT ELECTRON BEAM PROCESSING IN VACUUM	344
Spiridonova T. V., Kortov V. S., Zvonarev S. V. COMPUTER SIMULATION OF SPECTRAL-KINETIC CHARACTERISTICS IN NANOSTRUCTURED ALUMINA UNDER PULSED ELECTRON BEAM EXCITATION	346
Starikov S. V., Pisarevd V. V. ATOMISTIC SIMULATION OF SWIFT HEAVY ION-INDUCED MODIFICATION AND TRACK FORMATION IN NUCLEAR MATERIALS	347
Yakubik D. G., Pak V. Kh. QUANTUM-MECHANICAL CALCULATION OF THE INTERMEDIATE PRODUCTS OF RADIOLYSIS OF POTASSIUM PICRATE	348
Yakushin V.L., Dzhumaev P.S., Kalin B.A., Aung Thurein Hein, Isaenkova M.G., Leontyeva-Smirnova M.V., Polsky V.I., Perlovich Yu.A., Emelyanova O.V. and Naumenko I.A. MODIFICATION OF THE STRUCTURAL-PHASE STATE OF FERRITIC-MARTENSITIC STEELS BY HIGH-TEMPERATURE PULSED PLASMA FLOWS	348

Yan S., He S. K., Zhu Y.Z., Zhang B. Y., Xue J. M., Wang Y. G. PERFORMANCE OF ODS W UNDER TRANSIENT HIGH THERMAL LOAD	350
Yaresko S.I. FRICTIONAL PROPERTIES OF OXIDE FILMS OF LASER TREAT- MENT ZONE OF THE TOOL STEELS	350
Xiao YU, Yang LI, Xiaoyun LE, Gaolong ZHANG, Jie ZHANG, Jie SHEN, Huaizhe XU, Weijiang ZHAO NUMERICAL SIMULATION OF THE INTERACTION BETWEEN HIGH INTENSE PULSED ION BEAM AND TI TARGET	352

Modification of material properties

Abidzina V. , Tereshko I. , Red'ko V. THE MODIFICATION OF METALS AND ALLOYS PROCESSES IN LOW-TEMPERATURE DISCHARGE PLASMA	353
Asainov O.Kh., Umnov S.P. INCREASED ULTRAVIOLET REFLECTIVITY OF MAGNETRON DEPOSITED Al FILMS	354
Astashynski V.V., Cherenda N.N., S. O. Gluchko DYNAMIC SIMULATION OF THE TEMPERATURE FIELD OF POL- YCRYSTALLINE IRON UNDER THE ACTION OF COMPRESSION PLASMA FLOWS	355
Balikov D. V., Pak V. Kh, Miklin M. B., Nevostruev V. A. RADICAL PRODUCTE IN IRRADIATED CRYSTAL HYDRATE OF MAGNESIUM NITRATE	356
Borisov D. P., Koval N. N., Korotaev A. D., Kuznetsov V. M., Roma- nov V. Ya, Terekhov P. A., and Chulkov E. V. VACUUM-PLASMA TECHNIQUES OF HIGH-QUALITY PRODUCT SURFACE TREATMENT	357
Cherenda N. N. , Bibik N. V., Uglov V. V., Astashynski V. M., Kuzmitski A. M INTERMETALLIC PHASES SYNTHESIS IN THE SURFACE LAYER OF AL-SI ALLOY BY COMPRESSION PLASMA FLOWS IMPACT	357
Cherenda N. N., Uglov V. V., Smilgin A. A., Astashynski V. M., Kuzmitscki A. M., Remnev G .E REMOVAL OF OXIDE LAYERS FROM A STEEL SURFACE BY COMPRESSION PLASMA FLOWS	358

Contents

Dampilon B.V., Durakov V.G. MODIFICATION OF CHROME-VANADIUM WHITE IRON COATINGS BY IMPULSIVE ELECTRON-BEAM PROCESSING	359
Dauletbekova A., Maniks J., Manika I., Russakova A., Zabels R., Akilbekov A., Zdorovets M., Muhyshbayeva A., Umatova Z., Zhumazhanova A. STRUCTURAL DAMAGE IN LiF CRYSTALS IRRADIATED WITH FAST IONS	361
Denisova Yu.A., Ivanov Yu.F., Moskvina P.V., Teresov A.D., Koval N.N. MODIFICATION OF HARD ALLOYS BASED ON TUNGSTEN CARBIDE BY PULSED ELECTRON BEAM MELTING OF Ti COATING/WC-8%CO SUBSTRATE SYSTEM	362
Dorzhiiev A.D., Smirnyagina N.N., Milonov A.S., Semenov A.P. NANOSTRUCTURED LAYERS OF TRANSITIVE METALS BORIDES ON FAST-CUTTING STEELS R18 AND R6M5, GENERATED AT ELECTRON BEAM TREATMENT IN VACUUM	363
Durakov V.G., Gnyusov S.F., Dampilon B.V., Dehonova S.Z. MICROSTRUCTURE AND PROPERTIES OF VACUUM ELECTRON BEAM FACING CuCr25 ALLOYS	364
Dzhumaev P.S., Yakushin V.L., Kalin B.A., Aung Thurein Hein, Polsky V.I., Yurlova M.S. INCREASE OF THE CORROSION RESISTANCE OF LOW-ALLOY STEELS BY PULSED PLASMA FLOWS TREATMENT	365
Erofeev M.V., Tarasenko V.F., Khomjakov I.S., Medvedev A.S., Erofeev V.I. ZEOLITE-CONTAINING CATALYST TREATED WITH UV AND LOW-TEMPERATURE PLASMA	366
Fedorishcheva M. V., Sergeev V. P., Kalashnikov M. P., Voronov A.V. FEATURES FORMING OF MULTILAYERED NANOSTRUCTURING COATINGS ON THE BASIS OF Si-Al-N/Zr-Y-O SYSTEM, GENERATED BY MAGNETRON DEPOSITION METHOD	367
Gabdullina A. T., Zhukeshov A. M., Amrenova A. U., Mukhamedryskyzy M. THE MODIFICATION OF THE MATERIAL SURFACE UNDER THE PULSE IMPACT OF THE PLASMA FLOWS	368
Gavrilyuck A. O., Pak V. Kh., Miklin M. B., Nevostruev V. A. FORMATION OF PARAMAGNETIC CENTERS IN γ -IRRADIATED BARIUM NITRATE AT 300 AND 77K.	370

Gizbrekht M. V., Knyazeva A. G., Micolaichuk M.A. MODELS OF NON-ISOTHERMAL DIFFUSION UNDER SURFACE TREATMENT USING PARTICLE BEAMS	370
Gnusov S.F., Rotshtein V.P., Kitsanov, S.A., Mayer A.E., Khishchenko K.V, Levashov P.R. SHOCK-WAVE SPALL FRACTURE OF AUSTENITIC STEELS UN- DER THE ACTION OF A NANOSECOND RELATIVISTIC HIGH- CURRENT ELECTRON BEAM	371
Gritsenko B.P., Ivanov U.F., Koval N.N, Krukovskiy K.V., Girsova N.V., Teresov A.D., Lopatin I.V THE INFLUENCE OF THE SURFACE MODIFICATION AND BULK STRUCTURE MODIFICATION OF PURE TITANIUM VT1-0 AND TI- TANIUM ALLOY VT6 ON THEIR WEAR RESISTANCE	372
Ivanov Yu.F., Filimonov S.Yu., Teresov A.D., Budovskikh E.A., Gromov V.E. STRUCTURE AND PROPERTIES OF IRON-COPPER SYSTEM, FORMED BY ELECTRON-ION-PLASMA METHODS	373
Ivanov Yu.F., Petrikova E.A., Kolubaeva Yu.A., Teresov A.D., Filimonov S.Yu. NANOSTRUCTURAL POWDERS BASED ON ZIRCONIUM OXIDE: REGULARITIES AND MECHANISMS OF FORMATION OF PHASE COMPOSITION	375
Ivanov Yu. F., Teresov A.D., Soskova N. A., Raykov S. V., Budovskikh E. A., Gromov V. E. MODIFICATION OF STRUCTURE AND PROPERTIES OF TITANI- UM SURFACE LAYER BY ELECTROEXPLOSIVE ALLOYING AND ELECTRON-BEAM TREATMENT	376
Kabyshev A.V., Konusov F.V., Remnev G.E. THE SYNTHESIS OF GALLIUM ARSENIDE FILMS ON THE SILI- CON SUBSTRATE BY IONICS ABLATION	378
Kabyshev A.V., Lebed K.V. ELECTRICAL SURFACE CONDUCTIVITY IN DIELECTRIC MATE- RIALS INDUCED BY ION-THERMAL MODIFICATION	379
Kalashnikov M.P., Sergeev V. P., Fedorishcheva M. V., Neyfeld V. V., FEATURES FORMING OF MULTILAYERED NANOSTRUCTURING COATINGS ON THE BASIS OF Ni-Al SYSTEM, GENERATED BY MAGNETRONDEPOSITION METHOD	380
Kazimirov A.I., Erofeev E.V., Kagadei V.A. COPPER GERMANIUM ALLOYS FORMATION BY THE LOW TEMPERATURE ATOMIC HYDROGEN TREATMENT	381

Kretova O.M., Panin AV, Kazachenok M.S., Perevalova O.B, Teresov A.D. CHANGES IN THE STRUCTURE AND MECHANICAL PROPERTIES OF COMMERCIALY PURE TITANIUM UNDER THE INFLUENCE OF ELECTRON-BEAM PROCESSING	383
Krygina O. V., Lopatin I. V., Kovalsky S. S., Schanin P. M., Koval N. N., ION-PLASMA ETCHING AND CLEANING OF MATERIAL SURFACES IN PLASMA OF ARC LOW-PRESSURE DISCHARGE	384
Kubasov V.A., Engelko V.I., Kovalev V.G., OPTICAL CONTROL OF A METAL SURFACE MELTING UNDER ITS IRRADIATION BY PULSED INTENSE ELECTRON BEAM	385
Kul'ment'eva O.P. , Mahmood A.M. , Andreev A.A. PROPERTIES NANOCRYSTALLINE NITRIDE COATINGS, OBTAINED BY DIFFERENT REJIME	385
Le V. M., Zhevnyak V. D., Pak V. H., Nevostruev V. A. INFLUENCE OF GENERAL ABSORBED DOSE ON THE CONTENT OF THE GEL-FRACTION IN THE ION-EXCHANGE POLYMER HYDROGELS	386
Ligachev A.E., Golosova O.A., Ligacheva E.A., Polushin N.I., Potemkin G.V., Pushkarev A.I., Remnev G.E. THE MODIFICATION OF THE GRAPHITE SURFACE BY POWERFUL PULSED BEAMS OF C AND H IONS	387
Ligachev A.E., Bobryshev B.L., Bobryshev D.B., Earth G.Ya., Kaikanov M.I., Mukhametov A Ch., Ponomarev D.V., Potemkin G.V., Remnev G.E. SURFACE MODIFICATION OF MAGNESIUM ALLOYS UNDER THE ACTION OF PULSED ELECTRON BEAMS OF NANOSECOND DURATION	388
Menshakov A. I., Gavrilov N. V. LOW-TEMPERATURE (400 °C) NITRIDING OF 12KH18N10T STEEL IN ELECTRON BEAM PLASMA	389
Nikitenkov N.N., Sigfusson I.T., Tyurin Yu.I., Sypchenko V.S., Saprykina A.O., Vilkhivskaya O.V. RESEARCHING of HYDROGEN ACCUMULATION in the SAMPLES of PALLADIUM, SILVER and SILVER-PALLADIUM ALLOY	390
Novoselov A.A., Bayankin V.Ya., Gilmutdinov F.Z. LONG-RANGE EFFECT OF ION IMPLANTATION AND ITS INFLUENCE ON CHEMICAL COMPOSITION OF ROLLED COPPER-NICKEL FOILS.	391

Contents

Orlov V.L., Orlov A.V., Gumirov M.A. HYDRODYNAMIC INSTABILITY IN METALS SUBJECTED TO STRONG BEAMS OF CHARGED PARTICLES	392
Orlovskii V.M., Savinykh Yu.V. RESEARCH MODIFICATION OF LIQUID HUDROCARBONS IRRADIATED BY A NANOSECOND E-BEAM	392
Ostapenko M.G., Meisner L. L., Lotkov A.I., Koval N.N., Gudimova E.Yu. INFLUENCE OF THE PULSED ELECTRON BEAM TREATMENTS ON THE STRUCTURAL-PHASE CONDITIONS AND RESIDUAL STRESSES IN THE TiNi SURFACE LAYERS	393
Panchenko A. N., Alekseev S. V, Bulgakova N. M., Genin D. E., Losev V. F., Panchenko Yu. N. CONTROLLABLE MICROSTRUCTURE GROWTH ON LIQUIDMETAL SURFACES IN REACTIVE ATMOSPHERES:EXPERIMENT AND THEORY	394
Petrikova E. A., Ivanov Yu. F., Gromov V. E., Budovskih E.A., Bibik N.V., Cherenda N.N. MODIFICATION OF THE STRUCTURE AND PROPERTIES OF SILUMIN BY COMBINED METHOD INCLUDING ELECTROEXPLOSIVE ALLOYING FOLLOWED BY ELECTRON-BEAM TREATMENT	395
Polosatkin S.V., Burdakov A. V., Grishnyaev E. S., Konstantinov S. G., Shoshin A. A. FREAK STRUCTURES ON THE SURFACE OF COPPER TARGET IRRADIATED BY ION BEAM	397
Poltavtseva V. P., Kislitsin S. B., Koval N. N., Oskomov K. V. PECULIARITIES OF HIGH-CURRENT ELECTRON BEAM EFFECT ON THE STRUCTURE OF Ni-Ti ALLOY SURFACE IMPLANTED BY KRYPTON IONS	398
Poplavsky V.V., Matys V.G., Dorozhko A.V. COMPOSITION AND ELECTROCATALYTIC PROPERTIES OF SURFACE LAYERS PRODUCED ON CARBON SUBSTRATES WITH USE OF PLATINUM ION BEAM DEPOSITION FROM PULSED ARC-DISCHARGE PLASMA	399
Poplavsky V.V., Matys V.G., Bely I.M. CORROSIVE PROPERTIES OF COATINGS PRODUCED ON ALUMINIUM AND STEELS SUBSTRATES WITH USE OF CHROMIUM ION BEAM DEPOSITION	400

Contents

Rau A.G., Belyuk S.I., Osipov I.V. THREE-DIMENSIONAL MODIFICATION OF THE SURFACE BY THE PLASMA CATHODE ELECTRON GUN	401
Remnev A.G., Shalnov K.V., Uemura K. EFFECT OF PLASMA PROPERTIES AND SET-UP GEOMETRY ON THE MEDICAL NEEDLE ION PLASMA SPUTTERING PROCESS	402
Rotshtein V.P., Kolubaeva Yu.A., Mei X., Markov A.B., Naiden E.P., Oskomov K.V., Pryadko E.L., Teresov A.D., Shulepov I.A., Shulov V.A. EFFECT OF PARAMETERS OF PULSED ELECTRON-BEAM MELT- ING OF Al (FILM)/Ti (SUBSTRATE) SYSTEMS ON PHASE FOR- MATION AND PROPERTIES OF Ti-Al SURFACE ALLOYS	403
Savkin K. P., Burachevsky Ju. A., Nikolaev A. G., Oks E. M., Tyunkov A.V., Yushkov G. Yu. FORMATION OF THE CONDUCTIVE LAYERS WITH HIGH RE- SISTANCE IN THE SURFACE OF ALUMINA BY METAL ION IM- PLANTATION	404
Shugurov V.V., Teresov A.D., Denisova Yu.A., Petrikova E.A., Ivanov Yu.F. THE METHOD OF SURFACE MODIFICATION OF METALS AND ALLOYS, INCLUDING OF THE ELECTROEROSION ALLOYING FOLLOWED BY ELECTRON-BEAM TREATMENT	405
Shulov V.A., Bytzenko O.A., Teryaev D. A., Engelko V. I., Tkachenko K.I. THE INFLUENCE OF EXPOSURE TO INTENSE PULSED ELEC- TRON BEAMS ON NiCrAlY VACUUM-ARC COATINGS ADHESION TO GAS TURBINE ENGINE BLADES MADE OF GH326NK ALLOY	406
Shulov V.A., Bytzenko O.A., Teryaev D.A., Engelko V. I., Tkachenko K.I., Perlovich Yu.A., Isaenkova M.G., Fesenko V.A. TEXTURE FORMATION IN SUPERFICIAL LAYERS OF TARGETS MADE OF VT9 ALLOY DURING THEIR IRRADIATION WITH IN- TENSE PULSED ELECTRON BEAMS	407
Shymanski V.I., Uglov V.V., Cherenda N.N., Astashynski V.M., Kuzmitski A.M. MODIFICATION OF STRUCTURE AND MECHANICAL PROPER- TIES OF TITANIUM ALLOYS BY COMPRESSION PLASMA FLOWS INFLUENCE	408
Slobodyan M.S., Remnev G.E., Shubin B.G., Zhuravlev M.V. OPTIMIZATION OF STEEL SPARK CLEANING TECHNOLOGY	409

Smirnyagina N.N., Radnaev B.V., Radnaev B.V., Milonov A.S., Dasheev D.E.	410
STRUCTURE, PHASE COMPOSITION, HEAT RESISTANCE, PLAS- TICITY AND THERMAL STABILITY NANOSTRUCTURAL BO- RIDES TRANSITIVE METALS LAYERS ON CARBON STEEL S45 AFTER ELECTRON BEAM PROCESSING IN VACUUM	
Sorokova S. N., Knyazeva A. G., Pobal I. L., Denizhenko A.R.	411
ESTIMATION OF THE STRESSES IN THE COATING GROWING THE DEPOSITION OF METAL IONS AND CARBON FROM THE ELECTRIC ARC PLASMA IMPULSE	
Stepanova E. N., Grabovetskaya G. P., Mishin I. P., Teresov A. D., Grigoryev S. V.	412
EFFECT OF PULSED ELECTRON BEAMS EXPOSURE ON STRUC- TURAL AND PHASE STATES OF SUBMICROCRYSTALLINE Ti- 6Al-4V-H ALLOY	
Sypchenko V.S., Nikitenkov N.N., Sigfusson T.I. , Tyurin Y.I. , Vilkhivskaya O.V.	414
RADIATION-STIMULATED RELEASE OF HYDROGEN FROM NANOCRYSTALLINE TITANIUM OXIDE COATED BY ALUMINI- UM OXIDE	
Teresov A. D., Akhmadeev Yu. Kh., Koval N. N., Denisova Yu. A., Petrikova E. A., Shteynle A. V.	415
ELECTRON-BEAM SURFACE MODIFICATION OF MEDICAL SUP- PLIES	
Tyurin Yu.I., Sivov Yu.A., Sigfusson I.T., Khoruzhii V.D., Plotnikova E. Yu., and Syumkina L.I.	416
QUENCH of the RADICAL-RECOMBINATION LUMINESCENCE of CRYSTALLINE PHOSPHORS by OXYGEN	
Uglov V.V., Kuleshov A.K., Krutsilina E.A., Astashynski V.M., Kuzmitski A.M.	418
CHANGES OF T15K6 HARD ALLOY STRUCTURE AND PHASE COMPOSITION AS A RESULT OF NITRIDING BY COMPRESSIVE PLASMA FLOWS	
Uglov V.V., Remnev G.E., Kuleshov A.K., Rusalskiy D.P.	419
STRUCTURE AND MECHANICAL PROPERTIES MODIFICATION OF INSTRUMENTAL MATERIALS SURFACE LAYERS BY COAT- ING DEPOSITION AND HIGH INTENSITY ION BEAMS ACTION	
Vershinin D. S., Smolyakova M. Yu., Vershinina T. N.	420
NITRIDING OF TITANIUM ALLOY VT16 (Ti-3Al-4.5V-5Mo) IN PLASMA OF NON-SELSUSTAINED ARC DISCHARGE	

Contents

Vershinin D.S., Smolyakova M.Yu., Tregubov I.M. LOW-TEMPERATURE NITRIDING OF AUSTENITE STAINLESS STEEL IN PLASMA OF NON-SELFSUSTAINED ARC DISCHARGE	421
Vlasov I.V., Panin S.V., Sergeev V.P., Sungatulin A.R., Kalashnikov M.P. and Panin V.E. Zr ⁺ ION BEAM SURFACE LAYER STRUCTURE MODIFICATION IN 12CR1MOV STEEL AS A WAY TO IMPROVE ITS FATIGUE DURA- BILITY	422
Volkov N.V., Kalin B.A., Valikov R.A., Yashin A.S., Yalcev V.N. ION-BEAM TREATMENT THE OUTER SURFACE OF FUEL CLAD- DING FROM ZIRCONIUM ALLOYS BY RADIAL ION BEAM Ar ⁺	423
Yakovlev E. V. , Markov A. B. , Bestetti M., Brunella M. F, Petrov V. I. STRUCTURE AND PROPERTIES OF ZIRCONIUM-TITANIUM SUR- FACE ALLOY FORMED WITH A LOW-ENERGY HIGH-CURRENT ELECTRON BEAM	424
Yang LI, Jie ZHANG, Xiaoyun LE, Gaolong ZHANG, Xiao YU, Jie SHEN, Huaizhe XU, Weijiang ZHAO MEASUREMENT OF IMPULSE FOR PULSED ELECTRON BEAM ABLATION	425
Zakharov A. N., Sochugov N. S., Kozyrev A.V., Semenov V. A. PLASMA-IMMERSION ELECTRON SURFACE TREATMENT OF METAL SAMPLES	426
Zenin A. A., Klimov A.S., Kazakov A.V., Dvilis E.S., Khasanov O.L., Oks E.M. SINTERING OF ALUMINA CERAMICS USING PLASMA ELEC- TRON SOURCE	426
Zhao Y. H., Yu B. H., Dong L. M., Du H. ARC PLASMA-ASSISTED NITRIDING OF HIGH-SPEED-STEEL	427

Coatings deposition

Baranov E. A., Khmel S. Ya. EMISSION OF SiH IN FREE JET ACTIVATED BY ELECTRON- BEAM PLASMA	428
---	------------

Contents

- Denisov V.V., Shugurov V.V., Kalushevich A.A., Yakovlev V.V., Vorobyov M.S., Suslov A.I., Koval N.N.** 429
A SILICON FILMS DEPOSITION IN THE PROCESSES OF SiF₄ DECOMPOSITION IN PULSED GLOW DISCHARGE AND UNDER THE ACTION OF PULSED E-BEAM
- Dorofeeva T. I., Mamaeva V.A.** 430
HEAT-RESISTANT OXIDE CERAMIC NANOPOROUS COATINGS OBTAINED BY PULSE MICROPLASMA PROCESSES ON ZIRCONIUM
- Grigoriev V.U., Berlin E.V., Shchelkanov I.A.** 431
NITRIDE AND OXIDE FILM DEPOSITION IN HIGH DENSITY PLASMA OF A RADIO FREQUENCY PLASMA GENERATOR
- Ionov I.V., Sochugov N.S., Soloviev A.A., Kovalchuk A.N., Tcybenko A.O., Sigfusson T.I.** 432
SOLID OXIDE FUEL CELLS WITH THIN Ni-YSZ ANODES FABRICATED BY MAGNETRON CO-SPUTTERING
- Kamenetskih A.S., Gavrilov N.V., Kuznetsov M.V., Chukin A.V., Shishkina E.V.** 433
INVESTIGATION of TiC/a-C:H COATINGS DEPOSITED BY MAGNETRON SPUTTERING OF TITANIUM IN Ar-C₂H₂ GAS MIXTURE, IONIZED BY ELECTRON BEAM
- Khaltarov Z.M., Milonov A.S., Teresov A.D., Koval N.N., Semenov A.P., Smirnyagina N.N.** 434
PHASE COMPOSITION, STRUCTURE AND MICROHARDNESS OF TiB₂ LAYERS ON CARBONACEOUS STEELS S20 AND U8A AT PROCESSING BY POWERFUL ELECTRON BEAMS IN VACUUM
- Khmel S. Ya.** 435
OPTICAL PROPERTIES AND GROWTH RATES OF SILICON FILMS SYNTHESIZED BY GAS-JET ELECTRON BEAM PLASMA CVD METHOD
- Kislitsin S.B., Kadyrzhanov K.K., Uglov V.V.** 436
EFFECT OF HEAVY ION IRRADIATION ON STRUCTURE AND PROPERTIES COATING BASED ON NITRIDE OF TRANSITION METALS
- Korotaev A.D., Ovchinnikov S. V., Borisov D. P.** 437
THE CONCEPTS OF DESIGN, THE FEATURES OF STRUCTURAL-PHASE AND ELASTIC STRESS STATE, PROPERTIES OF SUPERHARD AND ANTI-FRICTION COATINGS

Contents

Korotaev A.D., Borisov D.P., Litovchenko I.Yu., Andreev A.V., Romanov V.Ya., Terekhov P.A. THE AMORPHOUS-NANOCRYSTALLINE COATING CARBON-TiC ON THE SUBSTRUCTURAL STRENGTHENING TITANIUM	439
Kotov D., Khissamov A., Shiripov V., Yasunas A. EXTENDED MAGNETRON SPUTTERING SYSTEM PLASMA EFFECTS THAT LIMITING TARGET UTILIZATION	439
Koval N.N. EQUIPMENT AND PROCESSES OF COMPLEX ELECTRON-ION-PLASMA MODIFICATION OF MATERIALS AND ARTICLES SURFACE	440
Kripakova M. V., Knyazeva A. G., Goncharenko I. M. PHYSICAL AND CHEMICAL CHARACTERISTICS FORMATION OF MULTICOMPONENT COATINGS IN ARC VAPOR DEPOSITION CONDITIONS.	441
Krysina O. V., Ivanov Yu. F., Koval N. N. SYNTHESIS, STRUCTURE AND CHARACTERISTICS OF Al-Si-N COATINGS PREPARED BY VACUUM ARC PLASMA-ASSISTED METHOD	442
Krysina O. V., Ivanov Yu. F., Koval N. N., Doyle S., Baumbach T., Timchenko N. A., Galimov R. M. THERMAL STABILITY OF NANOCRYSTALLINE TERNARY SYSTEM COATINGS BASED ON TiN	443
Krysina O. V., Ivanov Yu. F., Koval N. N., Moskvina P. V. Ti-Si-N SUPERHARD NANOCRYSTALLINE COATING SYNTHESIZED BY VACUUM-ARC DEPOSITION WITH PLASMA ASSISTANCE	443
Krysina O. V., Nafikova N. R. THE EFFECT OF ARC PLASMA-ASSISTED DEPOSITION PARAMETERS ON CHARACTERISTICS OF Ti-Cu-N COATINGS	444
Kryukova O. N., Knyazeva A. G., Sergeev V. P., Lynyev A. G. MODELING OF THE PROCESS OF TIN COATING MODIFICATION UNDER Al^+ AND B^+ ION BEAMS IMPLANTATION	445
Lubenko D. M., Ahmadeev Yu. Kh., Krysina O. V., Chumakov Yu. A. INVESTIGATIONS ON THE EFFECT OF NITROGEN LASER BEAM ON THIN COATINGS	446

Neyfeld V. V., Sergeev V. P., Fedorishcheva M. V., Kalashnikov M.P. IONIC NANO STRUCTURING OF COPPER SUBSTRATE AND THERMOCYCLIC STABILITY OF HEAT-RESISTING Si-Al-N COAT- INGS	447
Ovchinnikov S. V., Korotaev A. D., Pinzhin Yu. P., Popov S. V. INVESTIGATION OF THE FEATURES OF STRUCTURAL STATE IN THE AREAS OF DEFORMATION AND FRACTURE IN SCRATCH TESTING AND NANOINDENTATION DOPED COATINGS BASED ON TITANIUM NITRIDE	448
Plotnikov S. A., Emlin D. R., Trachtenberg I. S., Gavrilov N. V. DEPOSITION OF TiC/a-C:H COATINGS BY ACETYLENE DECOM- POSITION IN TITANIUM ARC PLASMA	449
Pribytkov G.A., Korzhova V.V., Firsina I.A., Korosteleva E.N., Gurskih A.V. MULTICOMPONENT NITRIDE COATINGS DEPOSITED AT VACU- UM ARC EVAPORATION OF POWDER CATHODES	450
Rabotkin S.V., Sochugov N.S., Kovsharov N.F., Soloviev A.A., Oskomov K.V. POLYMER FILMS WITH LOW-E COATING TO REDUCE HEAT LOSS THROUGH WINDOWS	451
Sergeev V.P., Panin V.E., Rizakhanov R. N., Koroteev A. S. MULTILAYER HEAT-SHIELDING COATINGS ON THE BASIS OF Zr-Y-O/Si-Al-N WITH HIGH THERMAL-CYCLE DURABILITY	451
Sergeev O. V., Sergeev V. P., Fedorischeva M. V., Kalashnikov M. P., Voronov A. V., Sungatulin A. R. FORMATION OF GRADIENT COATINGS ON THE BASIS OF Ti-Al- B-N SYSTEM BY METHOD OF MAGNETRON DISPUTTERING AND ION BEAM BOMBARDMENT	453
Shandrikov M.V., Tyunkov A.V. FORMATION OF COMPOSITE COATINGS WITH ADJUSTABLE RATIO OF COMPONENTS.	454
Shymanski V.I., Uglov V.V., Cherenda N.N., Lushkevich V.A., Astashynski V.M., Kuzmitski A.M. TITANIUM NICKELIDE FORMATION BY COMPRESSION PLASMA FLOWS	455
Sidelev D.V., Yuryev Y.N. THE DEPOSITION THIN FILMS OF DIOXIDE TITANIUM BY MEANS OF DUAL MAGNETRON SPUTTERING	456

Contents

Sivkov A. A., Saigash A. S., Gerasimov D.Yu., Evdokimov A. A. INVESTIGATION PROPERTIES OF COPPER COATINGS OBTAINED PLASMODYNAMIC METHOD	457
Sivkov A. A., Saigash A. S., Gerasimov D.Yu., Evdokimov A. A. ON POSSIBILITY OF REGULATING THE HARDNESS OF COAT- INGS BASED ON TITANIUM NITRIDE, IN THE PROCESS OF DE- POSITING THEM TO METALLIC SUBSTRATES	458
Sivkov A. A., Saigash A. S., Kolganova Yu. L., Nazarova M. E. RESEARCH OF PROPERTIES OF COPPER COATINGS OBTAINED BY THE PLASMODYNAMIC METHOD	458
Soloviev A. A., Sochugov N. S., Ionov I. V., Kirdyashkin A. I., Kitler V. D., Maznoy A. S., Sigfusson T. I. FABRICATION OF METAL-SUPPORTED SOLID OXIDE FUEL CELLS	459
Uglov V. V., Grabchikov S. S., Lastovski S. B., Bogatyrov Yu. V., Pankratov P. V., A. G. Pyatkevich P. V. MULTILAYER FILM-TYPE STRUCTURES FOR RADIATION PRO- TECTION OF SEMICONDUCTOR DEVICES	459
Uglov V.V., Abadias G., Michel A., Zlotski S.V., Saladukhin I.A., Rovbut A.Y. EVOLUTION OF PHASE COMPOSITION AND CRYSTAL STRUC- TURE OF TiZrAlN COATINGS AT ITS DEPOSITION AND IRRADI- ATION	460
Yasyukevich M.M., Odnostoronceva T.I., Butyagin P.I. THE INFLUENCE OF THE ELECTRICAL PARAMETERS OF MAO- PROCESS ON PROPERTIES OF OBTAINED COATINGS	462
Yuryev Yury, Yuryeva Alena, Korzhenko Dmitry and Stepanova Olga DEPOSITION OF DLC FILMS FROM THE MAGNETRON DISCHARGE PLASMA	463
Yuryeva¹ A., Krivobokov V. A NEW METHOD FOR THE METALLIZATION OF CERAMIC SUB- STRATES FOR THE NEEDS OF POWER ELECTRONICS	464
Zamchiy A. O., Baranov E. A., Khmel S. Ya. OPTICAL STUDIES OF AMORPHOUS SILICON FILMS	465

Nanoscience and nanotechnology

Chernov I.P., Beresneeva E.V., Ivanova S.V., Koval N.N., Lider A.M., Pushlina N.S., Remnev G.E. PROPERTIES OF THE ZIRCONIUM ALLOY SURFACE MODIFIED BY PULSED ELECTRON AND ION BEAMS	466
Gulidova L.V. SORPTION CAPACITY INVESTIGATION OF CARBON NANOSTRUCTURE MATERIALS	467
Kurzina I.A., Sharkeev Yu.P., Kozlov E.V. STRUCTURAL REGULARITIES OF FORMATION OF GRADIENTE SURFACE LAYERS ON BASE OF INTERMETALLIC NANODIMENSIONAL PHASES AT ION IMPLANTATION	468
Kurzina I.A., Popova N.A., Nikonenko E.L., Kalashnikov M.P., Savkin K.P., Yushkov G.Yu., Oks E.M., Sharkeev Yu. P. STRUCTURAL STATE AND PHASE COMPOSITION OF THE FINE-GRAINED TITANIUM IMPLANTAD BY ALUMINIUM IONS	469
Legostaeva E.V., Sharkeev Yu.P., Gnedenkov S.V., Komarova, E.G., Egorkin V.S., Sinebryukhov S.L., Lyamina G.V., Khlusov I.A. THE MORPHOLOGY, PHYSICO-MECHANICAL AND ELECTRO-CHEMICAL PROPERTIES OF MICRO-ARC CALCIUM-PHOSPHATE COATINGS ON NANOSTRUCTURED TITANIUM SURFACE	471
Mashentseva A.A., Zdorovets M.V., Russakova A.V., Aubakirov B.N., Borgekov D.B. PET TRACK ETCH MEMBRANES IN ELECTROLESS TEMPLATE-ASSISTED SYNTHESIS OF SILVER NANOSTRUCTURES	472
Nikitin D. S., Sivkov A. A., Pak A. Ja. THE PLASMADYNAMIC SYNTHESIS OF SILICON CARBIDE	473
Pogrebnyak A.D., Zhollybekov B.R., Beresnev V.M., Komarov F.F., Konarski P., Uglov V.V, Kaverin M.V., Kolesnikov D.A., Makhmudov N.A., Grudnitskii V.V., Plotnikov S.V. SYNTHESIS OF SUPERHARD NANOSTRUCTURED COATINGS Ti-Hf-Si-N AND ANALYSIS OF THEIR PROPERTIES	474
Rakhmatullin I.A., Sivkov A.A., Pak A.Ya., Shanenkov I.I. PLASMODYNAMIC SYNTHESIS OF B-C-N SYSTEM CRYSTALLINE PHASES IN HYPERHIGH SPEED ELECTRODISCHARGED PLASMA JET	475

Contents

Sarychev V.D., Granovskiy A.U., Gromov V.E. NANODIMENSIONAL INTERNAL STRUCTURE FORMATION IN METALS UNDER THE ACTION OF PULSED ELECTRIC-EXPLOSION-INDUCED PLASMA JETS	476
Semenova A.A., Goodilin E.A., Semenov A.P., Semenova I.A., Ivanov V.K., Tretyakov Yu.D. PRODUCTION OF PHOTON CRYSTAL STRUCTURES: SILICON DIOXIDE - SILVER BY ION BEAM SPUTTERING OF SILVER	477
Sharkeev Yu. P., Kukarenko, Byeli A.V., Koval N.N., Ivanov Yu.F., Eroshenko A.Yu. IMPROVEMENT of FATIGUE LIFE of NANOSTRUCTURED TITANIUM with ION IMPLANTATION and ELECTRON BEAM TREATMENT	478
Shymanski V.I., Remnev G.E., Pavlov S.K., Uglov V.V., Samtsov M.P. CARBON NANOCCLUSERS FORMATION INTO THE SILICON AFTER HIGH INTENSE PULSED ION BEAMS INFLUENCE IN NITROGEN ATMOSPHERE	479
Sivkov A. A., Gerasimov D. Yu., Evdokimov A. A., Usikov A. I. COMPACTION OF POWDERS OF TITANIUM NITRIDE NANOPOWDER SYNTHESIS PLASMODYNAMIC BY SPARK PLASMA SINTERING	481
Sivkov A. A., Gerasimov D. Yu., Evdokimov A. A., Usikov A. I. DEPENDENCE OF THE SIZE OF TITANIUM NITRIDE PARTICLES AND THEIR AGGLOMERATION PROPERTIES FROM PARAMETERS PLASMODYNAMIC SYNTHESIS	481
Sokovnin S.Y., Murzakaev A.M, Il'ves V.G., Spirina A.V. RESEARCH OF NANOPOWDERS PROPERTIES PURE AND DOPED METAL OXIDES PRODUCED BY A METHOD OF PULSED ELECTRON BEAM EVAPORATION	482
Sokovnin S.Y., Zuev M. G, Il'ves V.G., Spirina A.V. RESEARCH OF NANOPOWDERS PROPERTIES OF NEW X-RAY CONTRAST SUBSTANCES AND THE PHOSPHORS PRODUCED BY A METHOD OF PULSED ELECTRON BEAM EVAPORATION	483
Sokovnin S.Y., Murzakaev A.M, Il'ves V.G., Spirina A.V. RESEARCH OF PROPERTIES NANOPOWDERS AND COVERINGS FROM ALUMINA IRON DOPED, PRODUCED BY A METHOD OF PULSED ELECTRON BEAM EVAPORATION	484
Spivak-Lavrov I.F., Kurmanbai M.S. ON BOUNDLESS WIRE MESH RESISTANCE COMPUTATION	484

Contents

Teresov A. D., Kryazhev Yu. G., Koval N. N., Likholobov V. A., Drozdov V. A., Trenikhin M. V. STRUCTURAL TRANSFORMATIONS OF TECHNICAL CARBON BLACK T900 UNDER THE ACTION OF A HIGH-ENERGY-DENSITY PULSED ELECTRON BEAM	486
Turmyshev I.S., Timoshenkova O.R., Murzakaev A.M. INVESTIGATION OF FIELD EMISSION PROCESS FOR ULTRATHIN FILMS OF ZIRCONIA: VOLT-AMPERE DEPENDENCES AND SPECTRA FINE STRUCTURE	487
Volokitin O.G., Lucenko A.V., Shehovcov V.V. RESEARCHES OF THE NANO-STRUCTURED GLASS-CRYSTALLINE MATERIALS PRODUCED BY PLASMA TECHNOLOGY	488
Voronov A.V., Sergeev V.P., Fedorishcheva M.V., Kalashnikov M.P. FORMATION OF MULTILAYERED COATINGS ON THE BASIS OF ALTERNATING NANOLAYERS CrN/AlN AND THEIR TRIBOLOGICAL PROPERTIES	489
Zherlitsyn A. G., Shiyan V. P., Kositsyn V. S., Gulidova L.V., Lider A.M., Postnikov P.S., Trusova M.E. PRODUCTION OF HYDROGEN AND CARBON NANOMATERIALS FROM NATURAL GAS FOR HYDROGEN STORAGE DEVICES	490
Zhukov A. S., Arkhipov V. A., Zmanovsky S. V., Bondarchuk S. S. SPRAY PYROLYSIS TECHNIQUE FOR CERAMIC POWDERS SYNTHESIS	491

