

APPLICATION OF THE OPTICAL DIAGNOSTICS DURING THE COMMISSIONING OF THE BOOSTER OF NSLS-II

S.M. Gurov[#], O.I. Meshkov^{#,1}, V.V. Smalyuk[#], X. Yang^{*}

[#]BINP, Novosibirsk 630090, Russia

¹NSU, Novosibirsk, 630090.Russia

^{*} BNL, Upton, NY 11973, USA

Abstract

Set of diagnostics of booster of NSLS-II includes 6 fluorescent screens (flags) and 2 synchrotron light monitors (SLM). These diagnostics were applied during booster commissioning for closing of the beam turn and measurement of beam dimensions. They are also useful tool in case of malfunction elimination. We describe the experience obtained with several types of diagnostics during commissioning of the booster of NSLS-II. The information that was useful for commissioning as well as advantages and disadvantages of each diagnostics is discussed as well as the details of calibration and design of the devices are discussed.

FLUORESCENT SCREENS

Six fluorescent screens (beam flags) were applied for booster commissioning and troubleshooting. Fluorescent screens with their optics and cameras were used to measure transverse beam profile and position in single-pass mode. A beam image is registered by a CCD camera GC1290.

The thickness of the Cerium-doped Yttrium Aluminum Garnet (YAG:Ce) plate of the screens is 0.1 mm. The plates are produced by Crytur Company (Czech Republic). The beam flag consists of an integrated system of

components that can be reconfigured and interchanged, whereby screen can be easily taken out of a UHV-compatible body.

This beam-destructive diagnostics usually plays a key role during commissioning of a machine. The first beam flag was used to adjust the septum and injection kickers to inject a beam into the Booster. To provide correct operation of the first arc magnets we can observe the beam on the second screen. To close the first turn, the same procedure could be repeated for all the arcs with the beam observation on the next screens. The beam flags are marked in the booster drawings as BR-CSVF1, BR-XSVF1, BR-XSVF2, BR-DSVF1, BR-ISVF1, BR-ISVF2, see Fig. 1.

The screen is placed inside a cylindrical volume and move inside and outside of the vacuum chamber. Sufficiently that cylinder as well as the screen is placed at the air. The CCD-camera is placed outside the median plane of the accelerator and is radiation-protected with the lead shield. The screen can move between two fixed positions with pneumatic actuator, inside and outside of the vacuum chamber. The extreme positions are equipped with end switches for control of the flag status. The bottom of the device body serves as a wake-field shield, when the beam flag is removed out of the chamber. Any replacement of the equipment does not need violation of the vacuum.

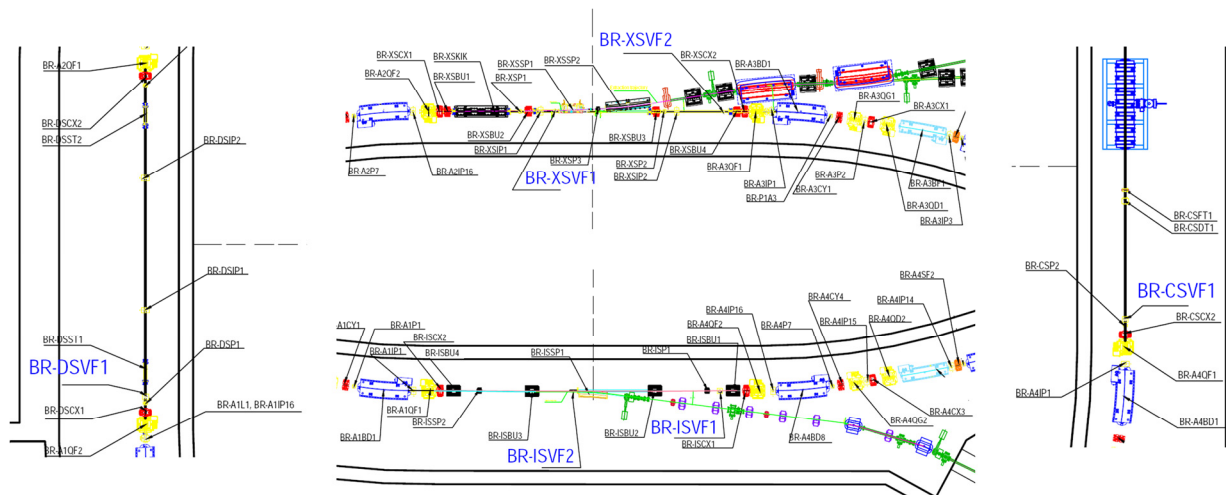

Figure 1: Locations of the beam flags along booster ring.

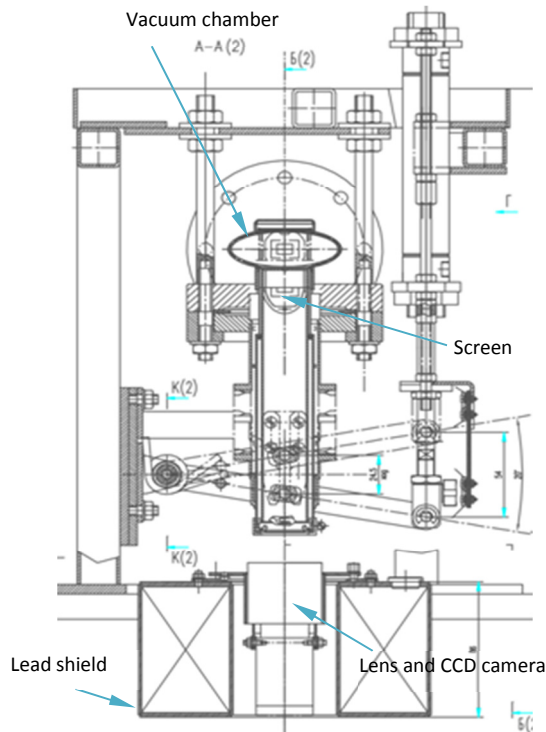

Figure 2: Kinematical scheme of the beam flag.

Expected resolution of the fluorescent screen is about 50 μm within the visible field of 20 mm [1].

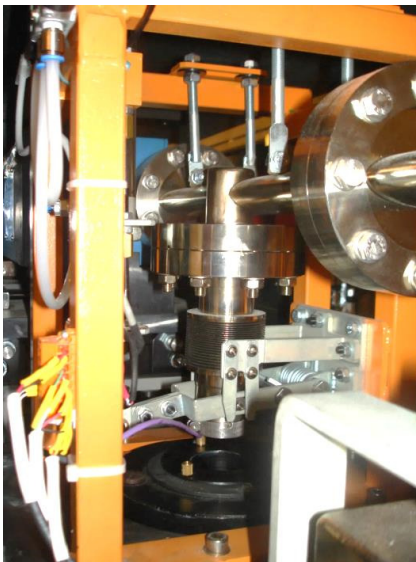

Figure 3: Beam flag at the booster ring.

The kinematic scheme and photo of the flag is presented at the Fig. 2, 3. The details of the screen calibration are described at [2].

FLAGS APPLICATION

The flags been tested mechanically at BINP before transportation to BNL. The tests been repeated after flags were installed at the booster ring and some disadvantages

of design of the flags were revealed. The devices are established and secured at girders of the magnets. The magnets and vacuum chamber been moved during geodesic alignment of the ring. It caused significant shifts of the upper part of the flags and led to the necessity of additional mechanical adjustment of them.

The first experiments with electron beam revealed high intensity of the light emitted by YAG:Ce screen at nominal linac current. It caused a saturation of CCD camera. We had to decrease light intensity with neutral filters setting them on the lenses. Some adjustment of the sensitivity of CCD camera could be made by using diaphragm of the lenses, but it required frequent visits to the booster tunnel. This possibility was limited by strict safety rules.

Nevertheless, flags helped to close a first turn of electron beam inside booster and to adjust septum and injection kickers. Beam “footprint” at the flag ICSVF1 is presented at Fig. 4.

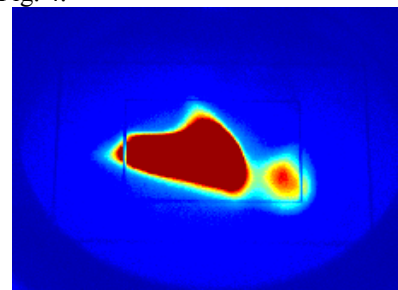

Figure 4: The first and the second turns observed on the beam flag ISVF1, Dec, 10, 2013.

SYNCHROTRON LIGHT MONITORS (SLM)

The synchrotron radiation (SR) monitor provides routine measurements of transverse beam profiles and beam sizes. It is used for the Booster performance optimization, operation monitoring and various beam physics studies. The monitor has ability to resolve small transverse beam dimension and slow motion with spatial resolution better than 50 μm in each plane. The synchrotron radiation monitor consists of a metallic mirror placed inside the vacuum chamber, light output window, image formatting optics and a CCD camera.

Parameters of synchrotron radiation at the extraction energy $E_{ext} = 3$ GeV computed for the beam current $I = 1$ mA, bending radius $\rho = 8.877$ m and circumference $C = 158.4$ m are the following:

- ultimate SR angular divergence is $\theta = 1/\gamma = 1.7 \cdot 10^{-4}$ rad;
- angular divergence of visible SR at $\lambda = 5000$ Å is $\theta_{opt} \approx 0.62 \left(\frac{\lambda}{\rho}\right)^{1/3} \approx 2.38 \cdot 10^{-3}$ rad;
- cone angle of SR fan in the horizontal plane is $\theta_r = 10.8$ mrad;
- critical energy is $E_c \approx \frac{5.59}{E^3} \rho = 6.75$ keV keV;
- optical resolution in the vertical direction is $d_y \approx \frac{\lambda}{2\pi\theta_{opt}} \approx 0.034$ mm;

– optical resolution in the horizontal direction is $d_x \approx \rho \frac{(\theta_{opt})^2}{2} \approx 0.025 \text{ mm}$.

The FWHM vertical size of SR spot on the extracting mirror placed at the distance of $L = 712 \text{ mm}$ is $d_x \approx 2.36 \cdot \theta \cdot L \approx 0.285 \text{ mm}$ for SR with $\lambda \approx \lambda_c$. For the visible part of radiation it has a value of $d_s \approx 4 \text{ mm}$. The vertical size of mirror is 24 mm, the maximum allowed deviations at the SR source points are: $\pm 12 \text{ mm}$ for vertical beam position, $\pm 16 \text{ mrad}$ for vertical angle, and $\pm 3.5 \text{ mm}$ for horizontal beam position.

The locations of SR extraction out of the vacuum chamber are chosen according to the following considerations: maximal vertical beam size; maximal free length of the vacuum chamber between the magnets.

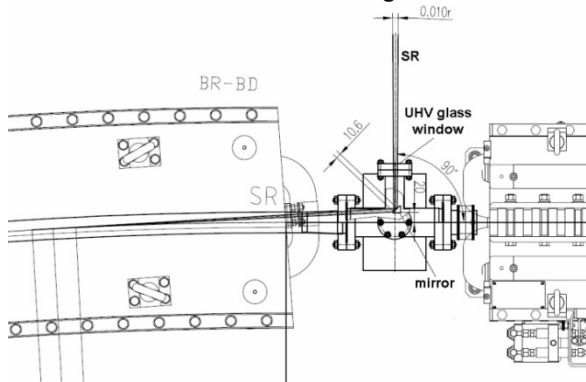

Figure 5: Layout of the SR extraction from BR-A3BD4 magnet.

As a result, the points of SR generation for output are in the BD dipole magnets (Fig. 5, 6). Two ports of SR output are proposed; the first one is located in the 3rd arc, the second one is close to the diagnostic straight section.

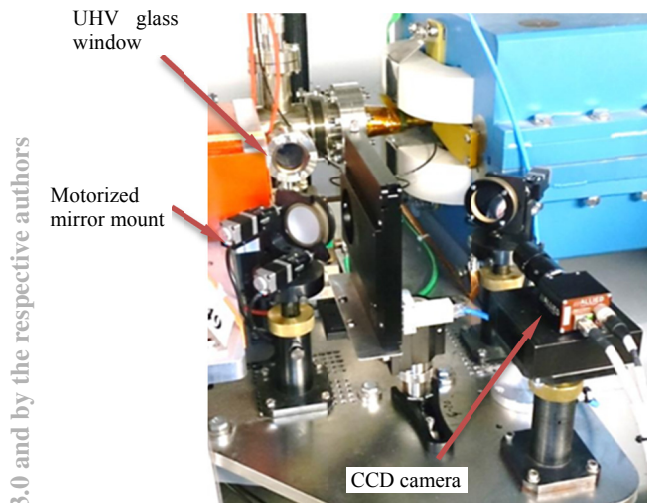

Figure 6: Image formatting optics and CCD camera installed at the booster ring.

SLM APPLICATION

The ports of SR output were equipped with CCD cameras. The getting of the beam image on CCD cameras

required some efforts. At first, with motorized mirror mounts was achieved a proper positioning of the image at CCD matrix. The very preliminary focusing of the image was achieved without beam. The final consistent improvement of focusing required several visits to the booster tunnel during different technical stops.

The diagnostics was capable to record about 10 beam images during rump of the booster energy from 200 MeV to 3 GeV (Fig. 7). It helped to control the behavior of the beam during this process.

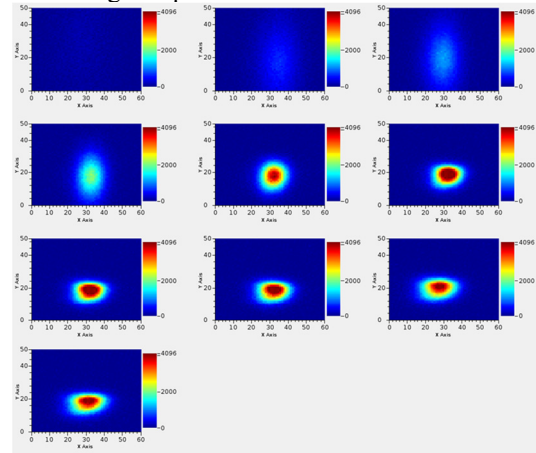

Figure 7: Beam images recorded by synchrotron light monitor during rump of booster energy from 200 MeV to 3 GeV. The temporal gap between frames is 40 msec.

OTHER DIAGNOSTICS

Two photomultipliers (PMT) were prepared and equipped by flanges for connection with glass windows. We intended to apply PMTs for setting of betatron capture of the beam. In fact, the PMTs were not used at all due to reliable operations of pickup electrodes.

The same fate befell beam loss monitors based on CsI crystals and plastic. These devices were mounted on the vacuum chamber of booster at the middle of the arcs, but did not apply during booster commissioning because synchrotron capture of the beam was reached very soon after start of the commissioning.

CONCLUSION

The optical diagnostics of the booster of NSLS-II accelerator have been described. The diagnostics were successfully applied during booster commissioning. Some useful experience thus obtained is presented.

REFERENCES

- [1] Proceedings of DIPAC09, WEOBE02, Hamburg, 2009.
- [2] Proceedings of DIPAC-2013, MOPME064, Shanghai, 2013.